



US00D533606S

(12) **United States Design Patent**
Kaminski

(10) **Patent No.:** **US D533,606 S**

(45) **Date of Patent:** **** Dec. 12, 2006**

(54) **COLLAPSIBLE CAR**

(75) Inventor: **Arek Kaminski**, Toronto (CA)

(73) Assignee: **Spin Master Ltd.**, Ontario (CA)

(**) Term: **14 Years**

(21) Appl. No.: **29/223,592**

(22) Filed: **Feb. 15, 2005**

(30) **Foreign Application Priority Data**

Dec. 9, 2004 (CA) 109354

(51) **LOC (8) Cl.** **21-01**

(52) **U.S. Cl.** **D21/548**

(58) **Field of Classification Search** D21/533,
D21/538, 541, 542, 548, 549, 551, 562; 446/431,
446/435, 454, 456, 465, 470, 6; D12/90,
D12/91, 92

See application file for complete search history.

(56) **References Cited**

U.S. PATENT DOCUMENTS

4,693,693	A	*	9/1987	Kennedy et al.	446/6
D346,990	S	*	5/1994	Abbott et al.	D12/91
5,380,231	A	*	1/1995	Brovelli	446/6
5,713,783	A	*	2/1998	Szoke et al.	446/456
D401,185	S	*	11/1998	McGovern	D12/91
D401,186	S	*	11/1998	Abbott et al.	D12/91
5,906,528	A	*	5/1999	Ostendorff et al.	446/6
D419,919	S	*	2/2000	McGovern	D12/91
D422,941	S	*	4/2000	Sigurosson	D12/91
D457,107	S	*	5/2002	Kember et al.	D12/91
D457,835	S	*	5/2002	Iso et al.	D12/91
D466,054	S	*	11/2002	Hsu	D12/92
D496,306	S	*	9/2004	Chapman	D12/92

OTHER PUBLICATIONS

Remote control crash car found on ebay, two pages.*
Remote control crash Hummer found on ebay, two pages.*
Shenzhen New Creation Import and Export Co. Model
1888CH Crashing car, found on Made In China.com, copy-
right 2006.*

* cited by examiner

Primary Examiner—Philip S. Hyder

(74) *Attorney, Agent, or Firm*—Cohen, Pontani, Liberman
& Pavane

(57) **CLAIM**

The ornamental design for a collapsible car, as shown and
described.

DESCRIPTION

FIG. 1 is a perspective view of the collapsible car with the
doors, hood, fenders, rear, and roof in closed position;

FIG. 2 is a top view of the collapsible car with the doors,
hood, fenders, rear, and roof in closed position;

FIG. 3 is a bottom view of the collapsible car with the doors,
hood, fenders, rear, and roof in closed position;

FIG. 4 is a left side view of the collapsible car with the
doors, hood, fenders, rear, and roof in closed position;

FIG. 5 is a right side view of the collapsible car with the
doors, hood, fenders, rear, and roof in closed position;

FIG. 6 is a front view of the collapsible car with the doors,
hood, fenders, rear, and roof in closed position;

FIG. 7 is a back view of the collapsible car with the doors,
hood, fenders, rear, and roof in closed position;

FIG. 8 is a perspective view of the collapsible car with the
doors, hood, fenders, rear and roof in open position;

FIG. 9 is a top view of the collapsible cars with the doors,
hood, fenders, rear and roof in open position;

FIG. 10 is a bottom view of the collapsible car with the
doors, hood, fenders, rear and roof in open position;

FIG. 11 is a left side view of the collapsible car with the
doors, hood, fenders, rear and roof in open position;

FIG. 12 is a right side view of the collapsible car with the
doors, hood, fenders, rear and roof in open position;

FIG. 13 is a back view of the collapsible car with the doors,
hood, fenders, rear and roof in open position; and,

FIG. 14 is a front view of the collapsible car with the doors,
hood, fenders, rear and roof in open position.

1 Claim, 6 Drawing Sheets

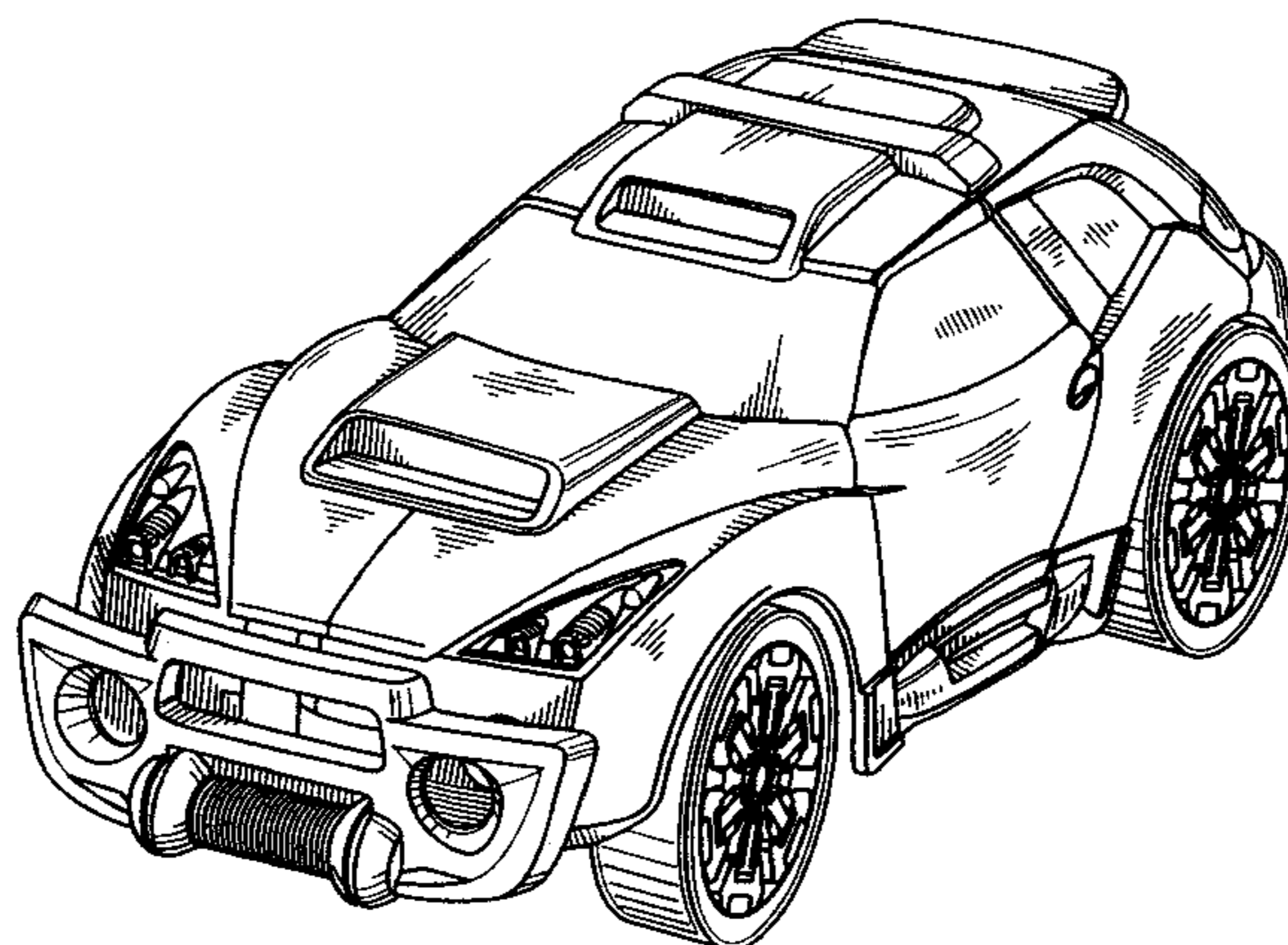

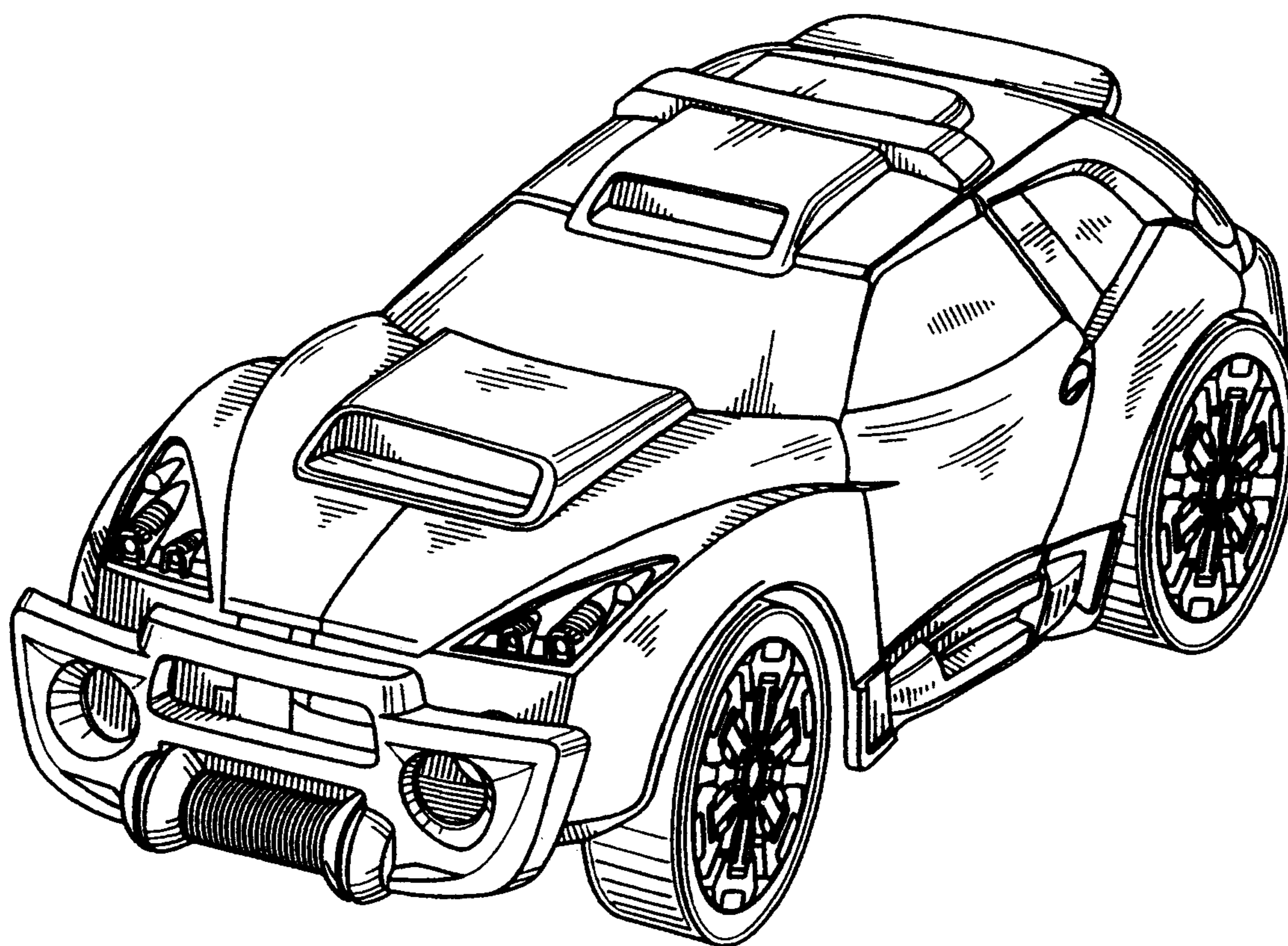

FIG. 1

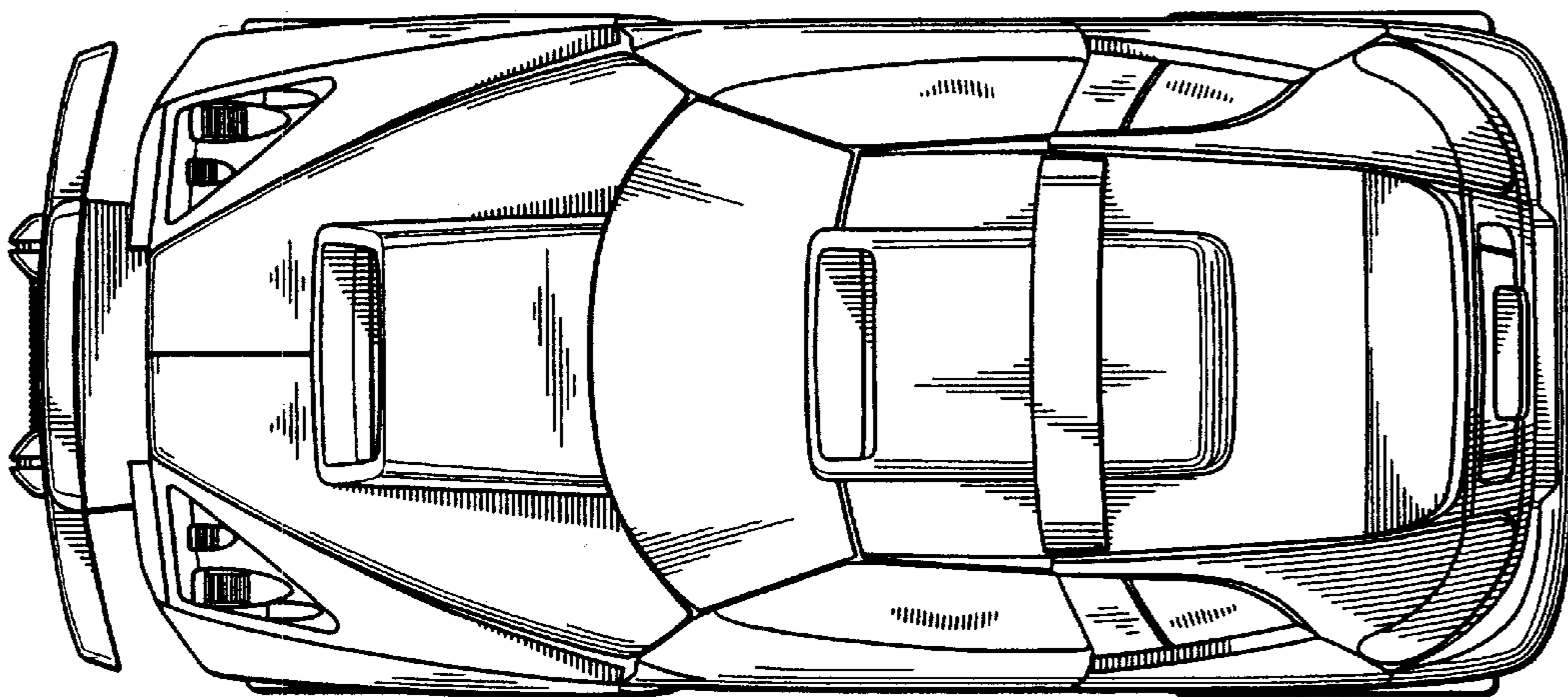

FIG. 2

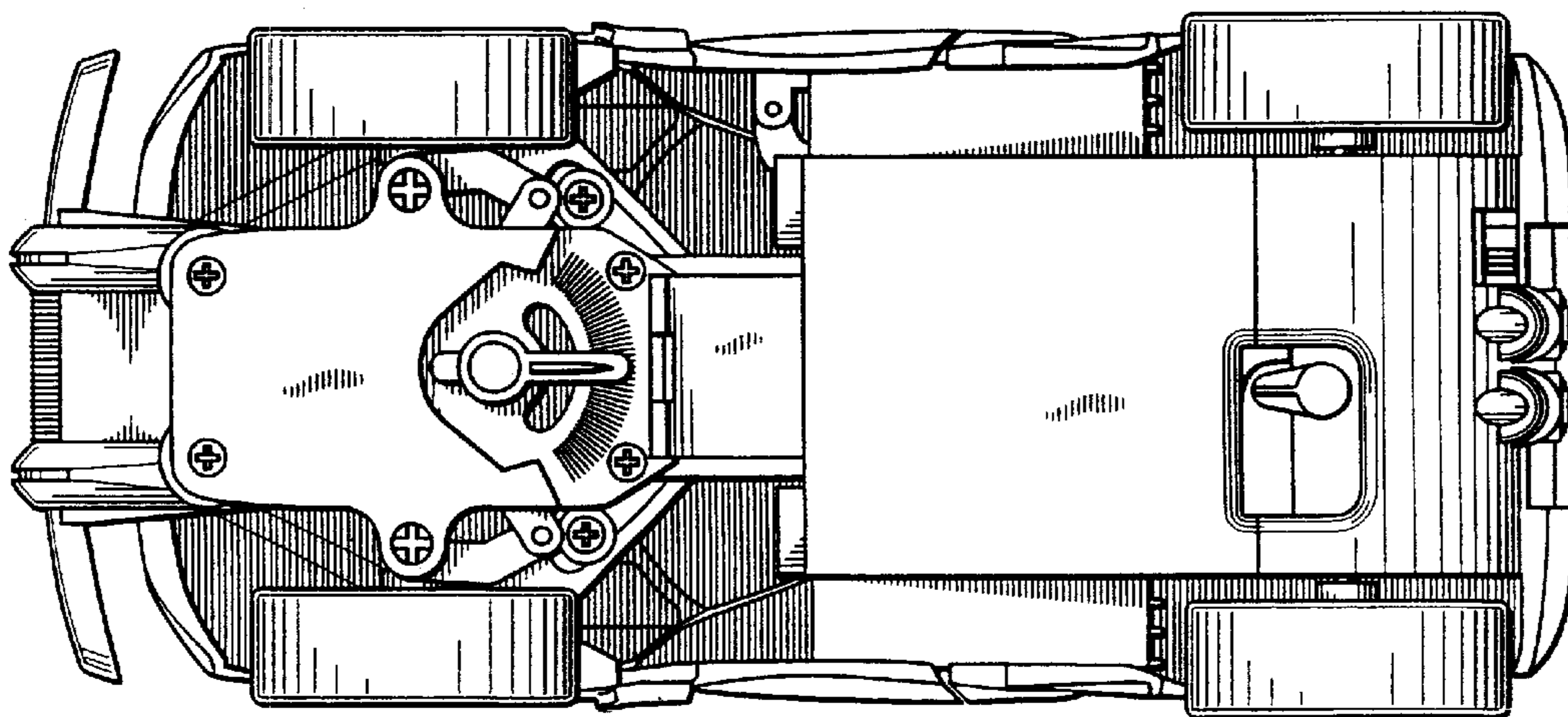

FIG. 3

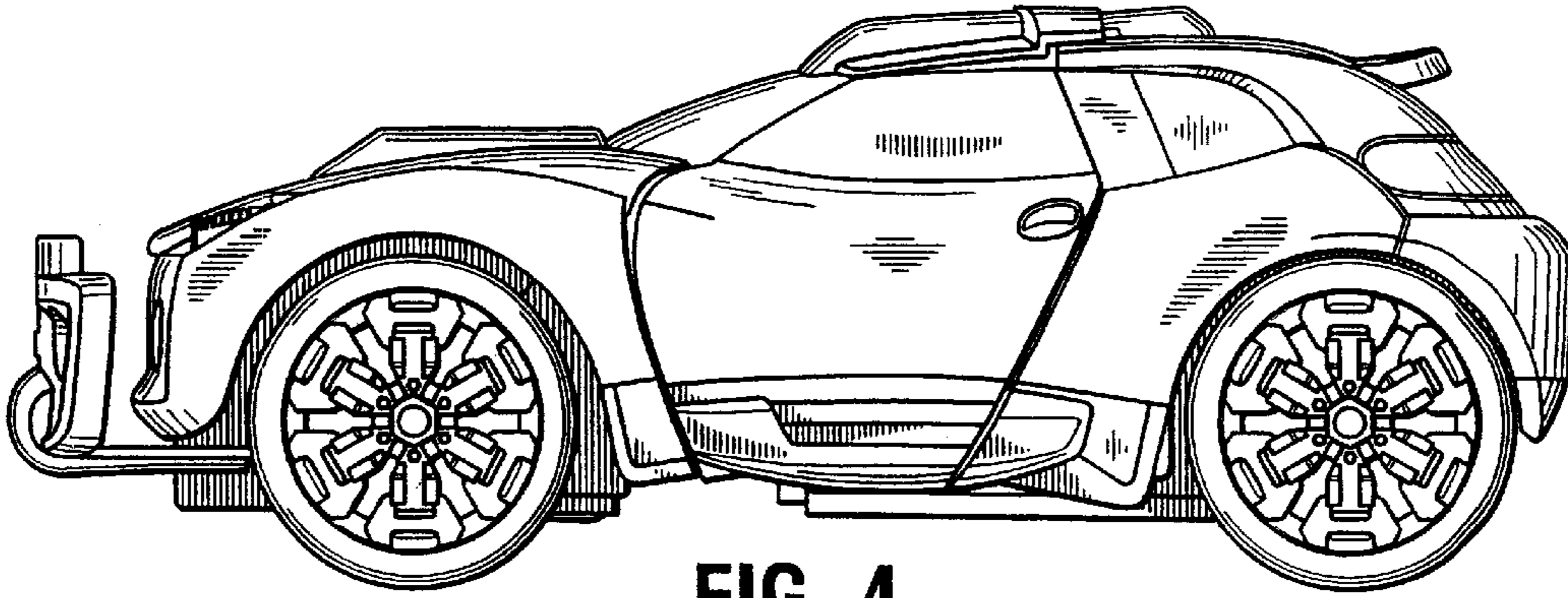

FIG. 4

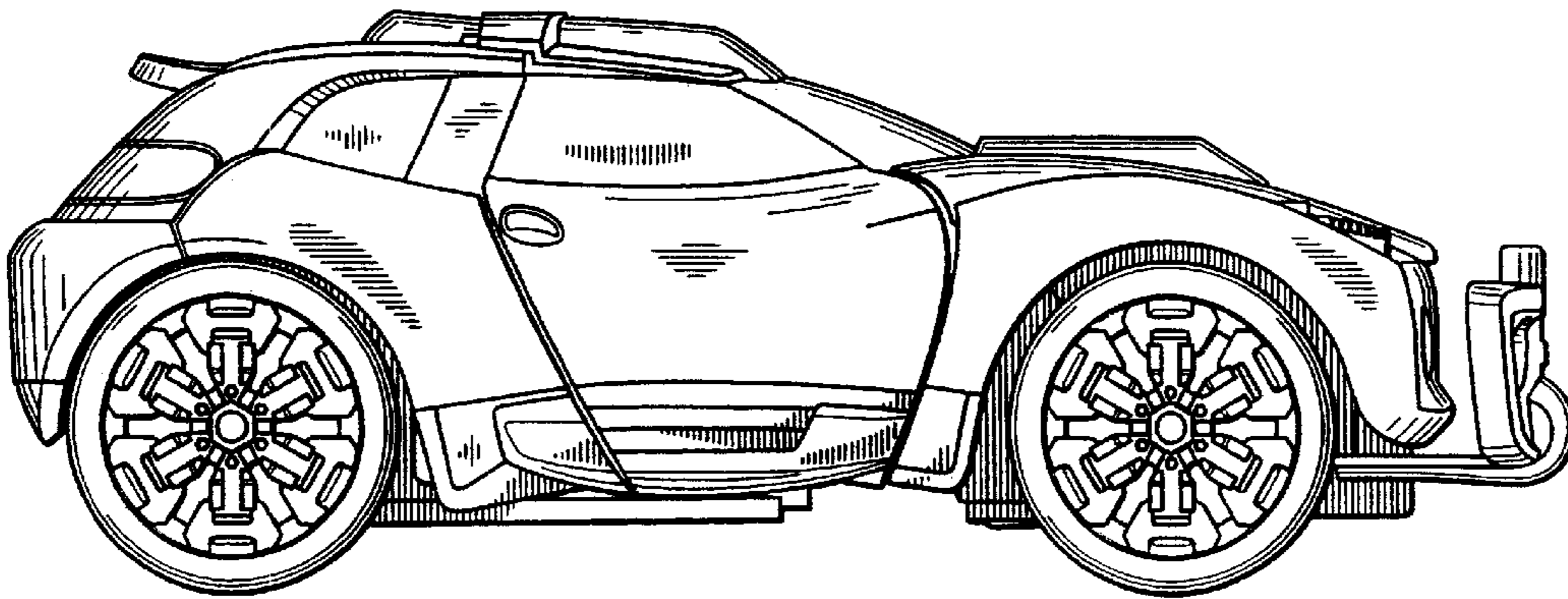

FIG. 5

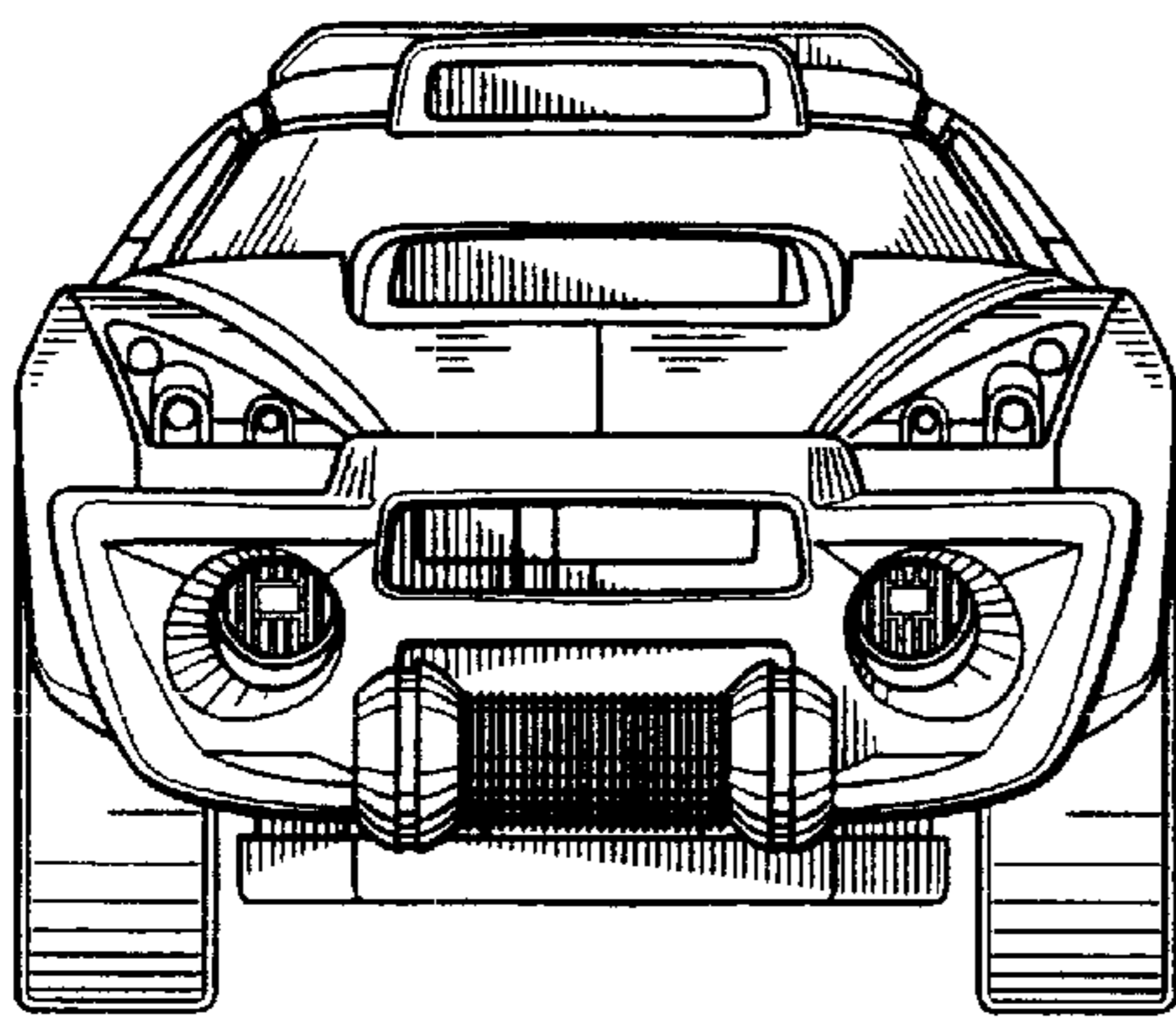

FIG. 6

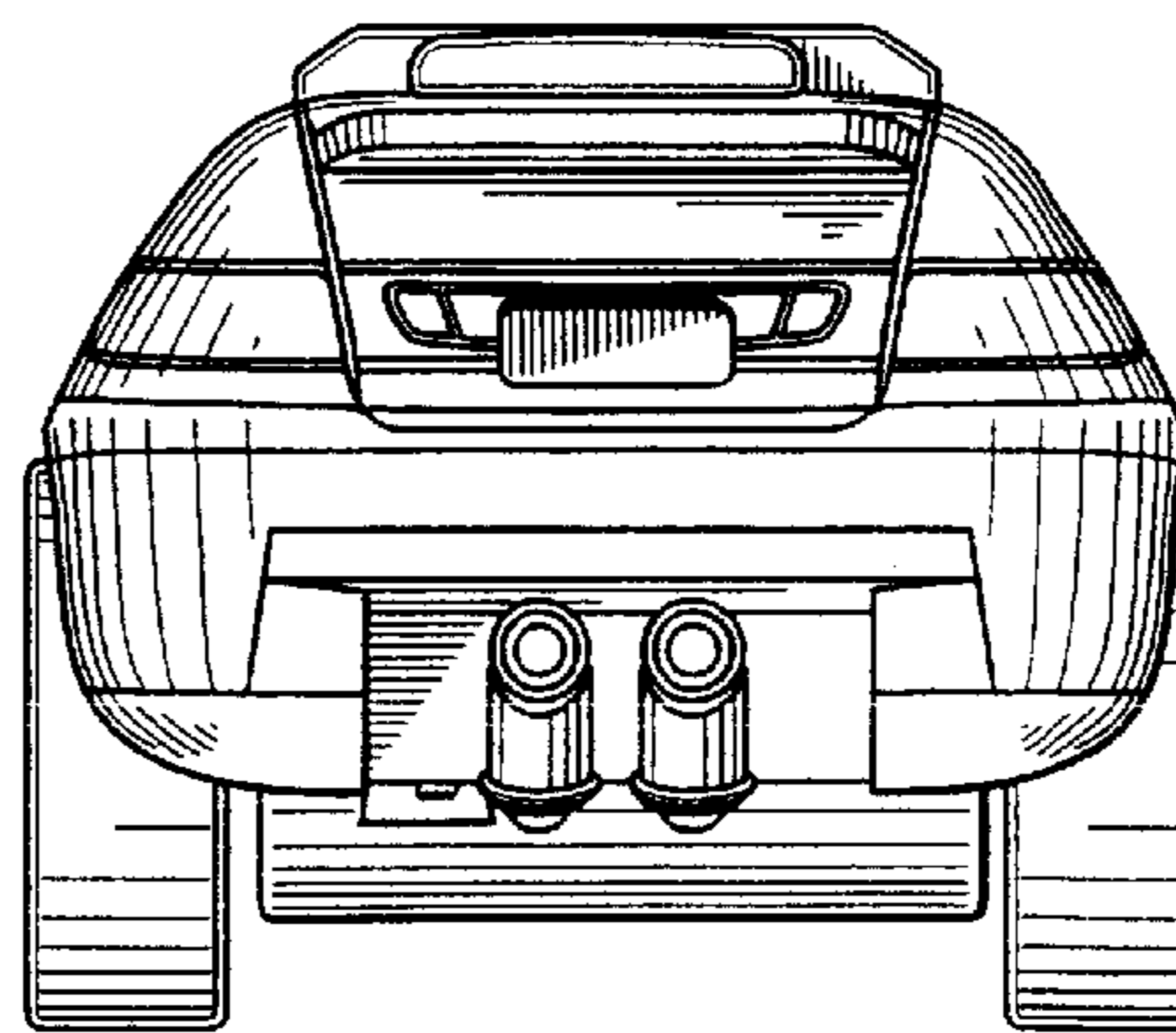

FIG. 7

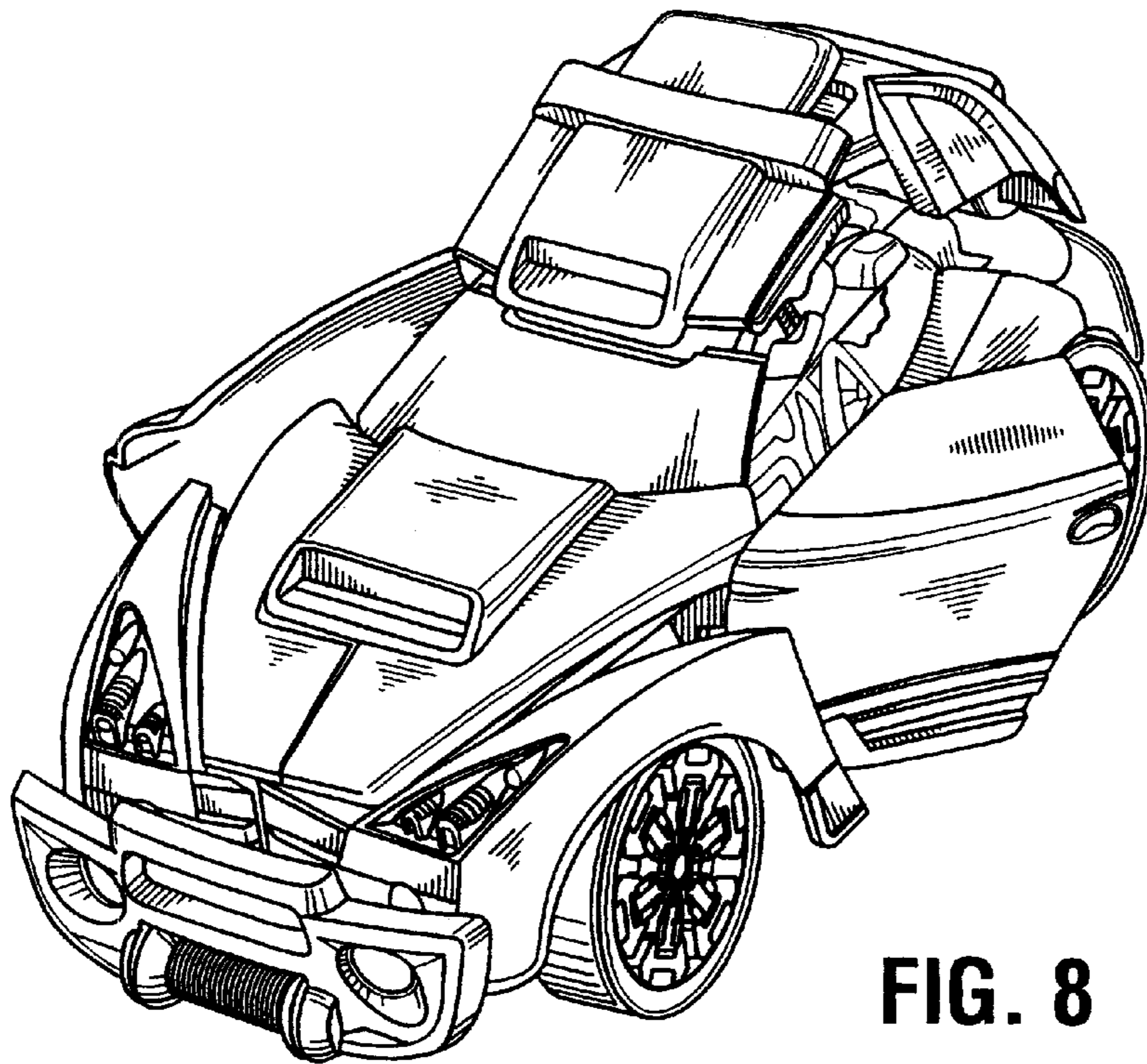

FIG. 8

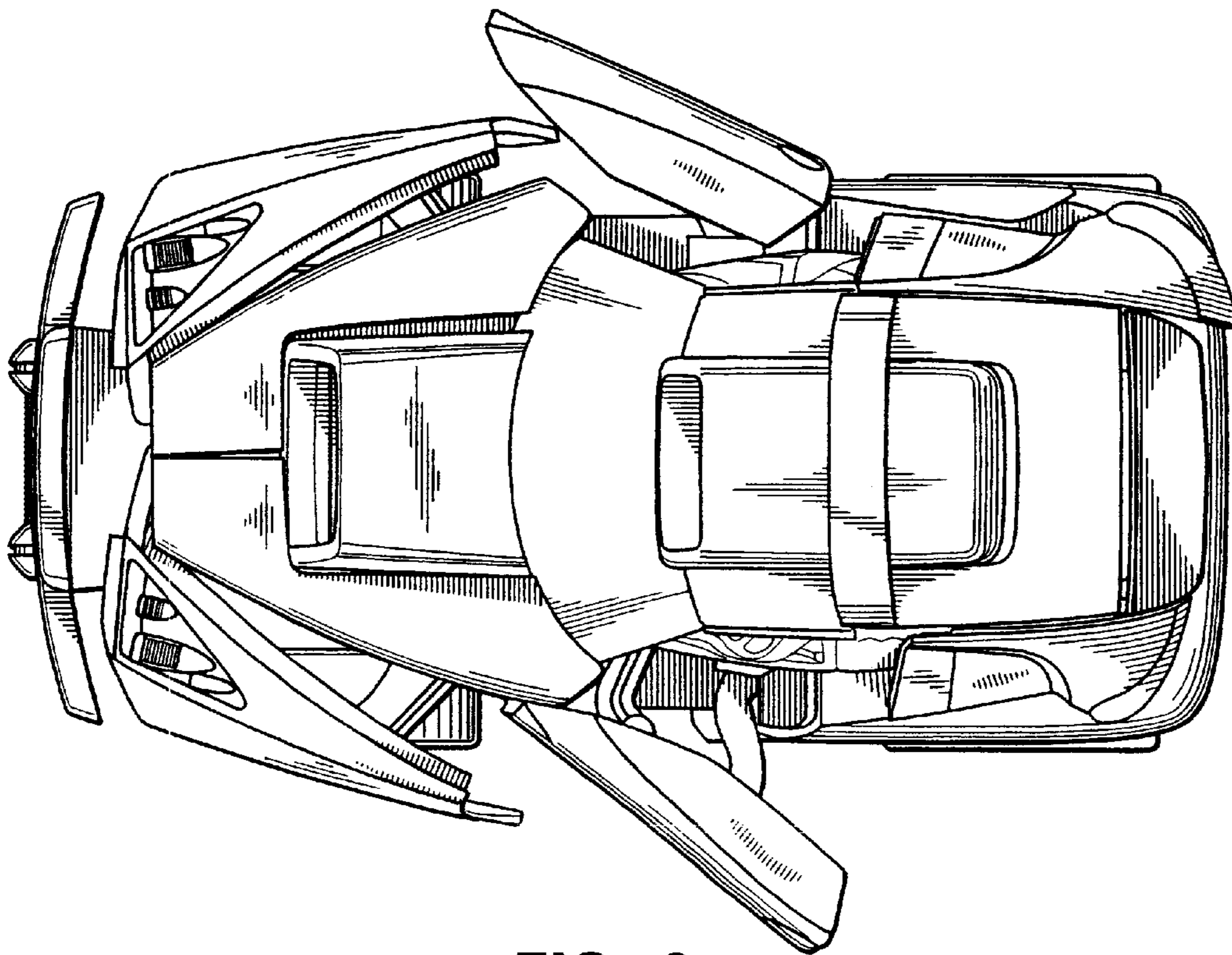

FIG. 9

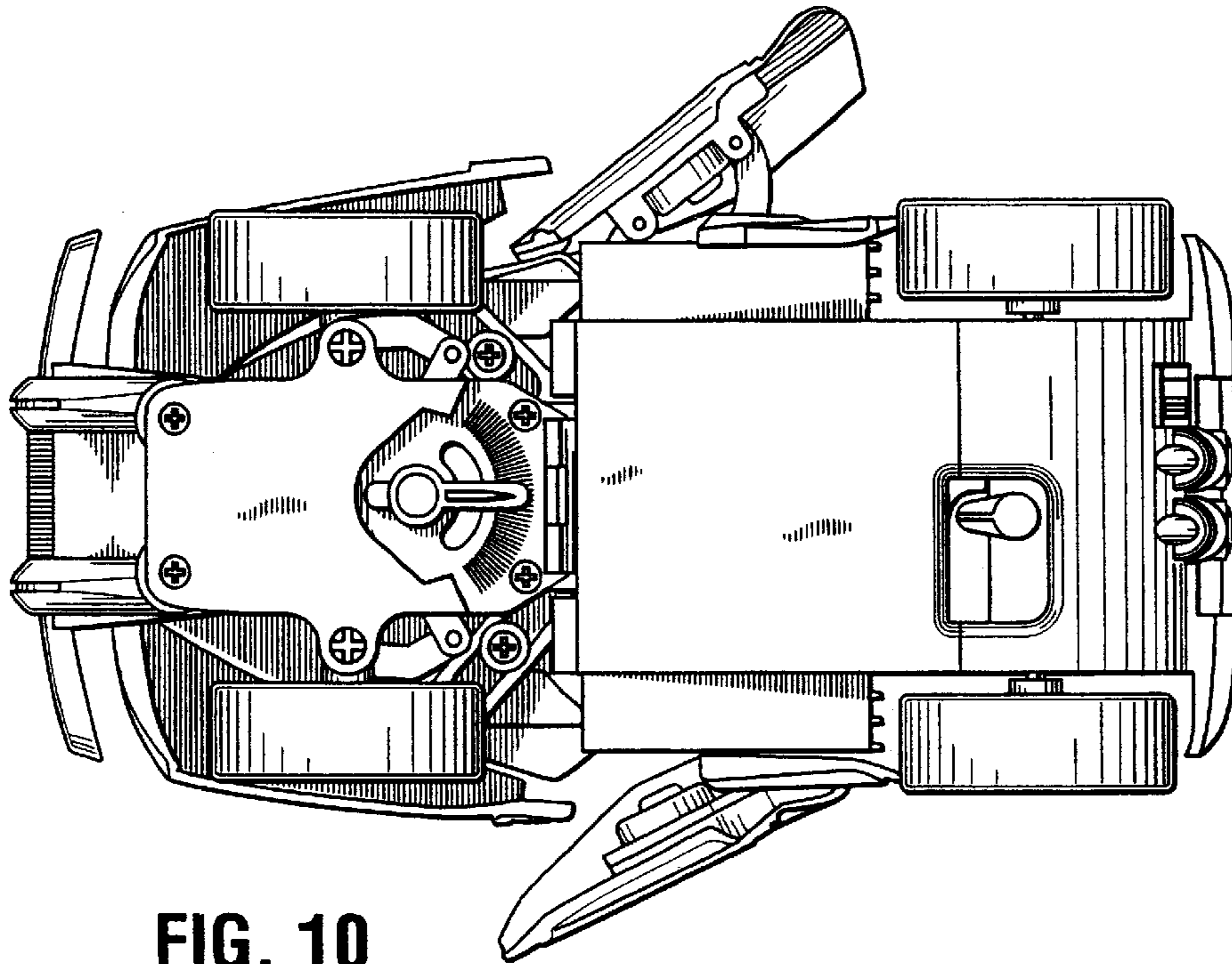

FIG. 10

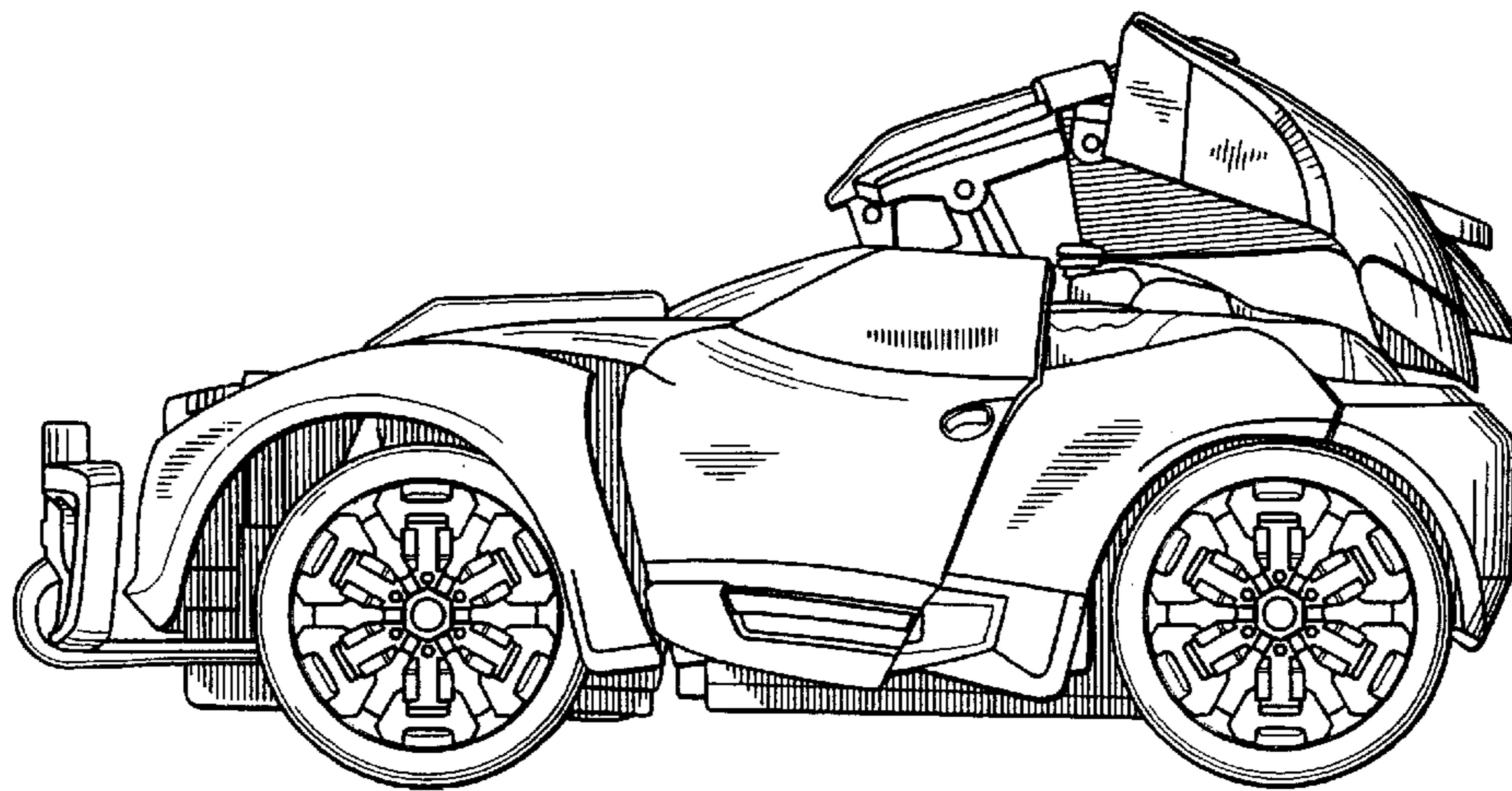

FIG. 11

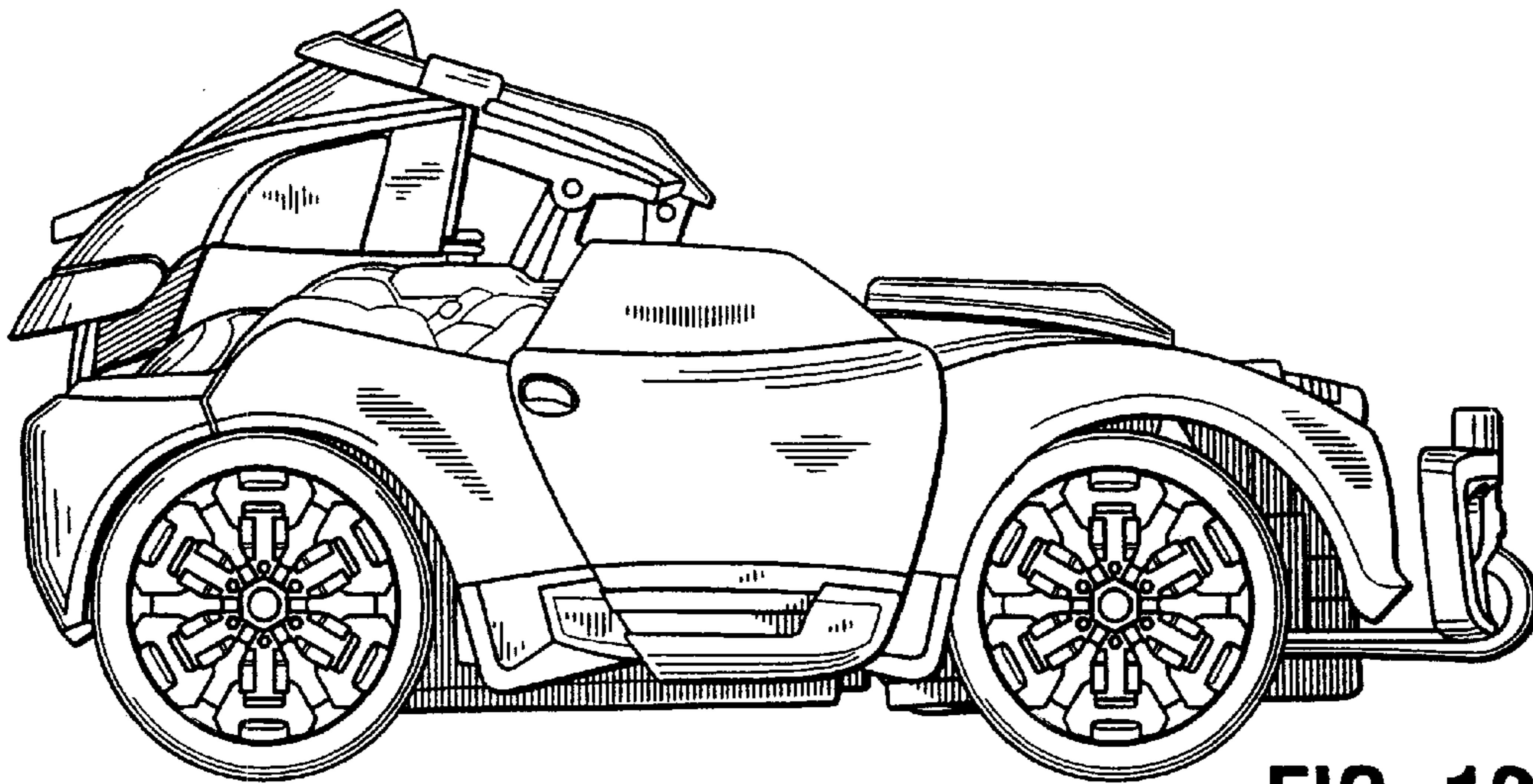

FIG. 12

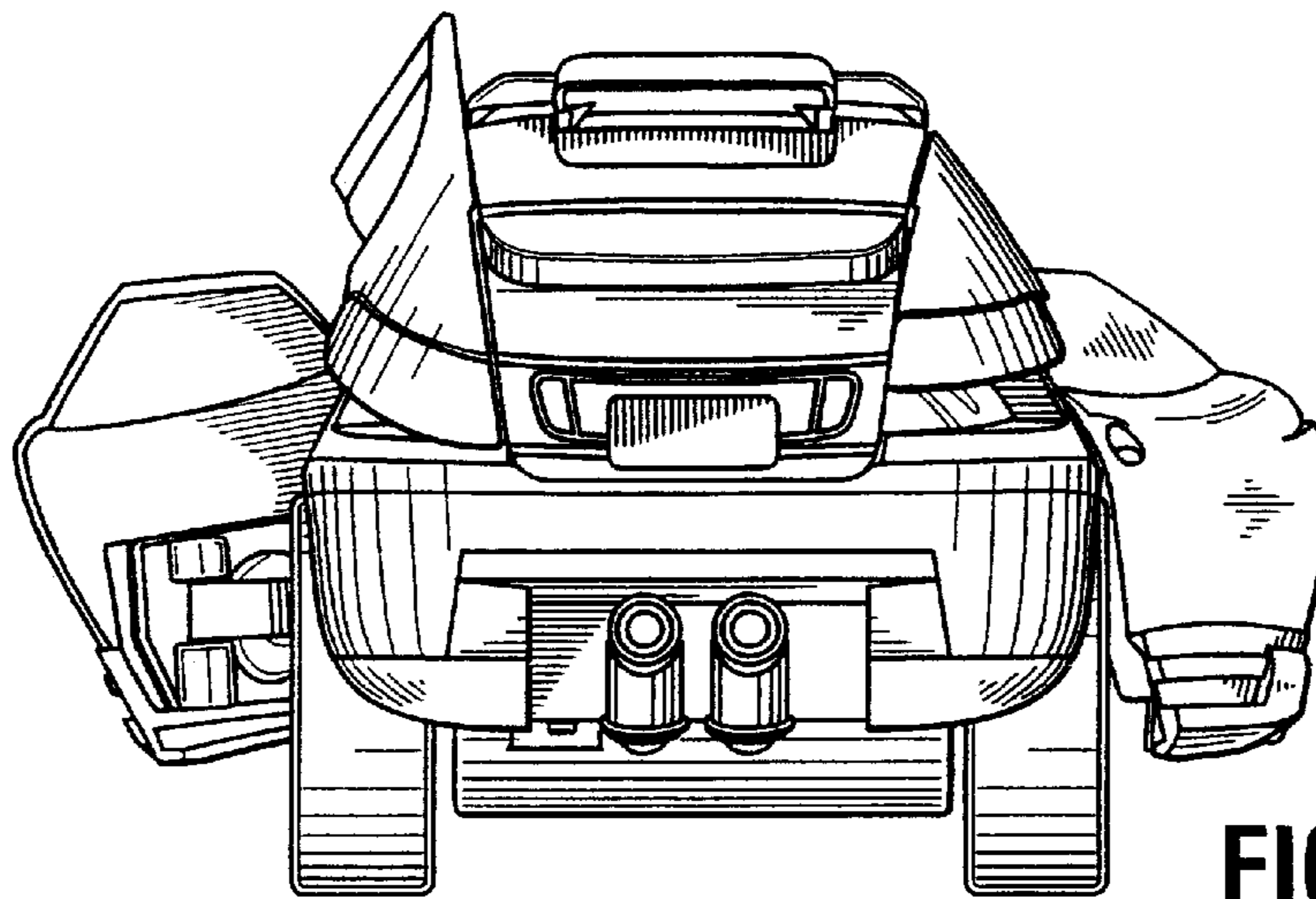

FIG. 13

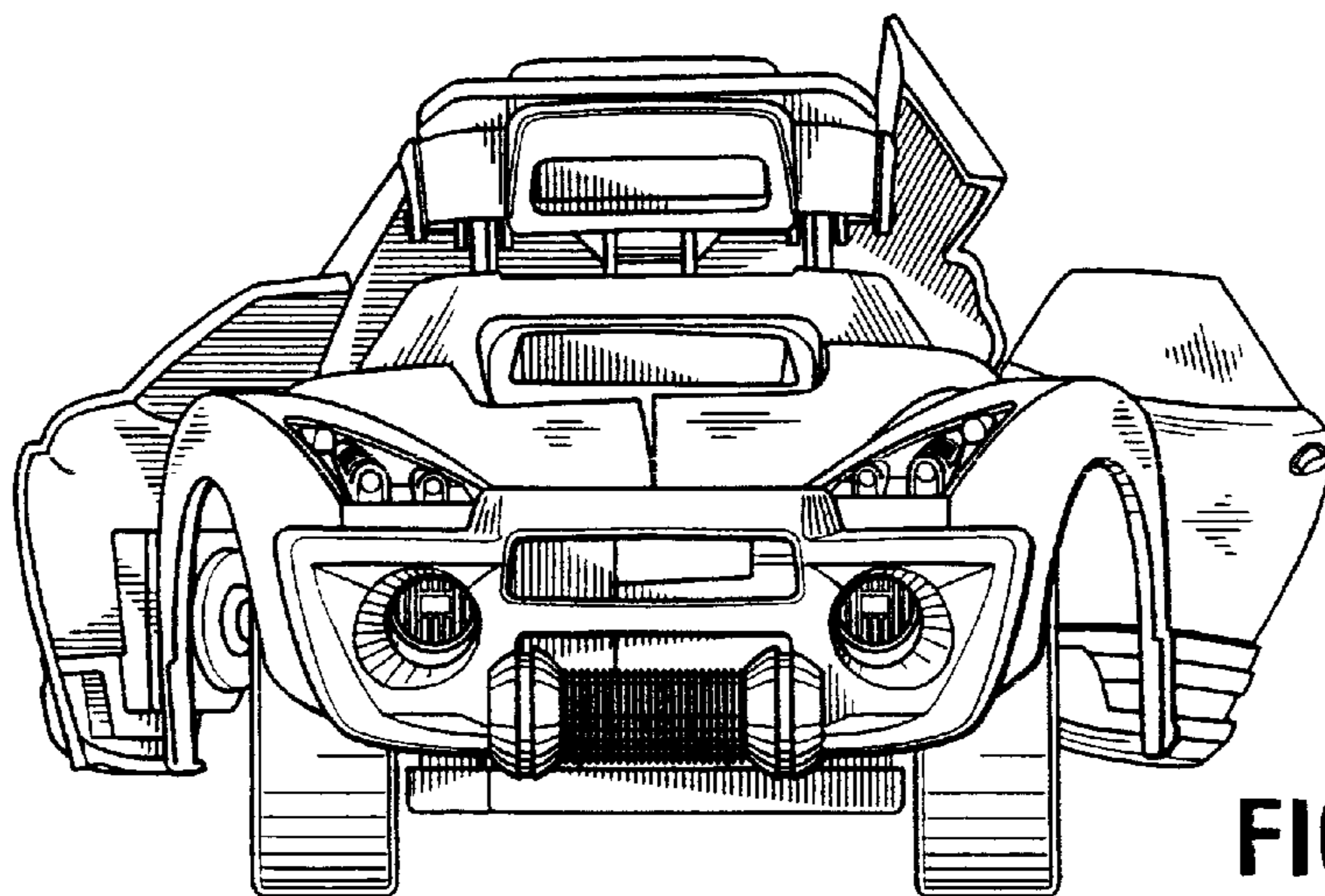

FIG. 14