



US00D533508S

(12) **United States Design Patent**
Suzuki et al.

(10) **Patent No.:** **US D533,508 S**

(45) **Date of Patent:** **** Dec. 12, 2006**

(54) **TUNER**

(75) Inventors: **Takumi Suzuki**, Katagami (JP);
Toshihiko Inaba, Katagami (JP);
Junichi Noro, Katagami (JP); **Shozo**
Miyamoto, Katagami (JP)

(73) Assignee: **Mitsumi Electric Co., Ltd.**, Toyko (JP)

(**) Term: **14 Years**

(21) Appl. No.: **29/254,197**

(22) Filed: **Feb. 21, 2006**

(30) **Foreign Application Priority Data**

Oct. 19, 2005 (JP) 2005-030540

(51) **LOC (8) Cl.** **13-03**

(52) **U.S. Cl.** **D13/147**

(58) **Field of Classification Search** D13/133,
D13/146-147, 149, 154, 184; 439/64, 79,
439/72-74, 246, 259, 278, 607-610, 862,
439/891, 894

See application file for complete search history.

(56) **References Cited**

U.S. PATENT DOCUMENTS

D271,686 S * 12/1983 Casciotti et al. D13/147

D492,935 S * 7/2004 Mitsuhashi et al. D13/147
6,773,308 B1 * 8/2004 Lwee 439/630
D509,191 S * 9/2005 Hu et al. D13/147
2005/0118877 A1 * 6/2005 Hu et al. 439/630
2005/0130498 A1 * 6/2005 Fan 439/630
2005/0162242 A1 * 7/2005 Ootori et al. 334/85

* cited by examiner

Primary Examiner—Stella Reid

Assistant Examiner—Daniel Bui

(74) *Attorney, Agent, or Firm*—Sughrue Mion, PLLC

(57) **CLAIM**

The ornamental design for a tuner, as shown.

DESCRIPTION

FIG. 1 is a perspective view of the top, front and right side of a tuner showing our new design;

FIG. 2 is a front elevational view thereof;

FIG. 3 is a rear elevational view thereof;

FIG. 4 is a top plan view thereof;

FIG. 5 is a bottom plan view thereof;

FIG. 6 is a left side elevational view thereof; and,

FIG. 7 is a right side elevational view thereof.

1 Claim, 3 Drawing Sheets

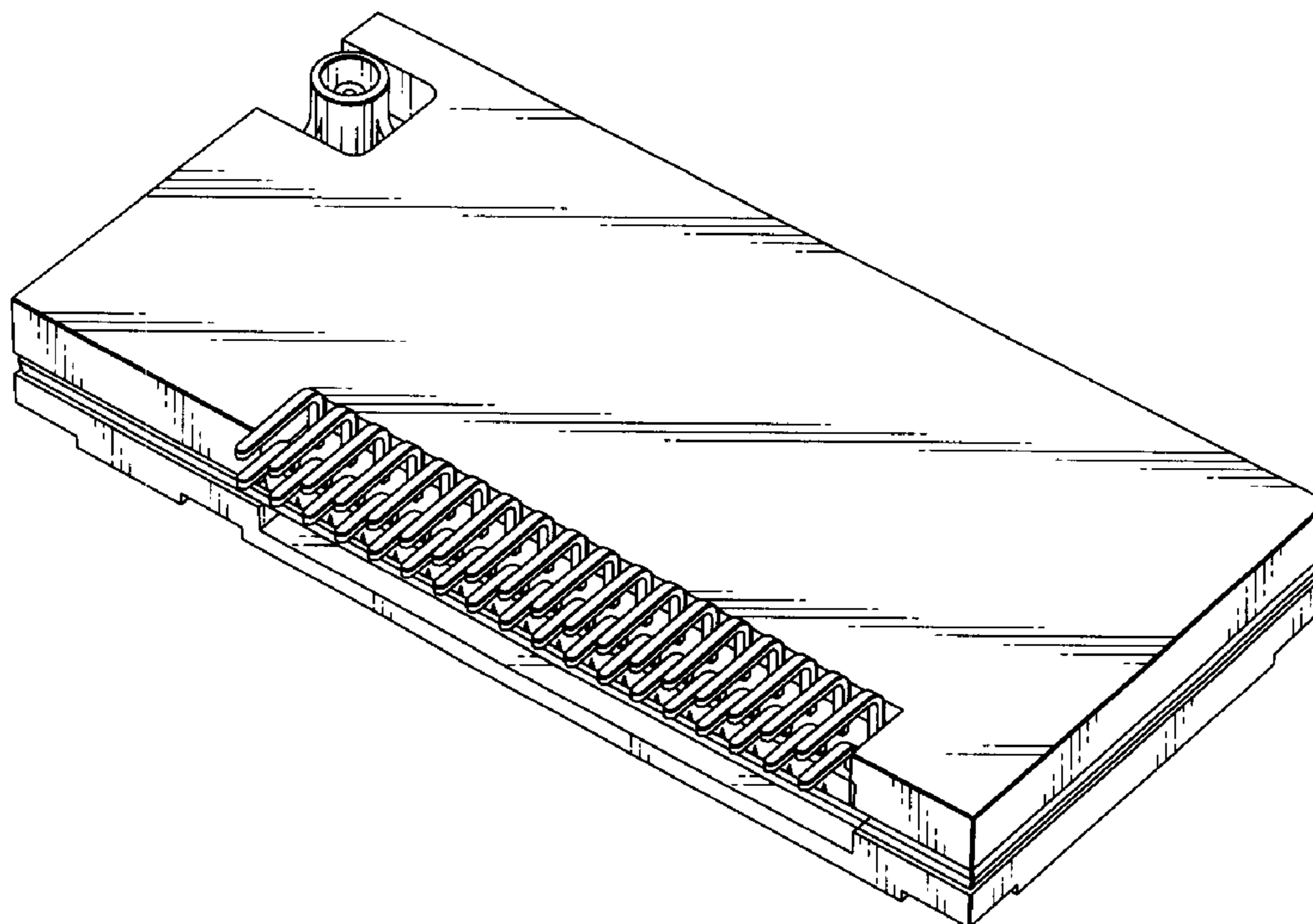

FIG.1

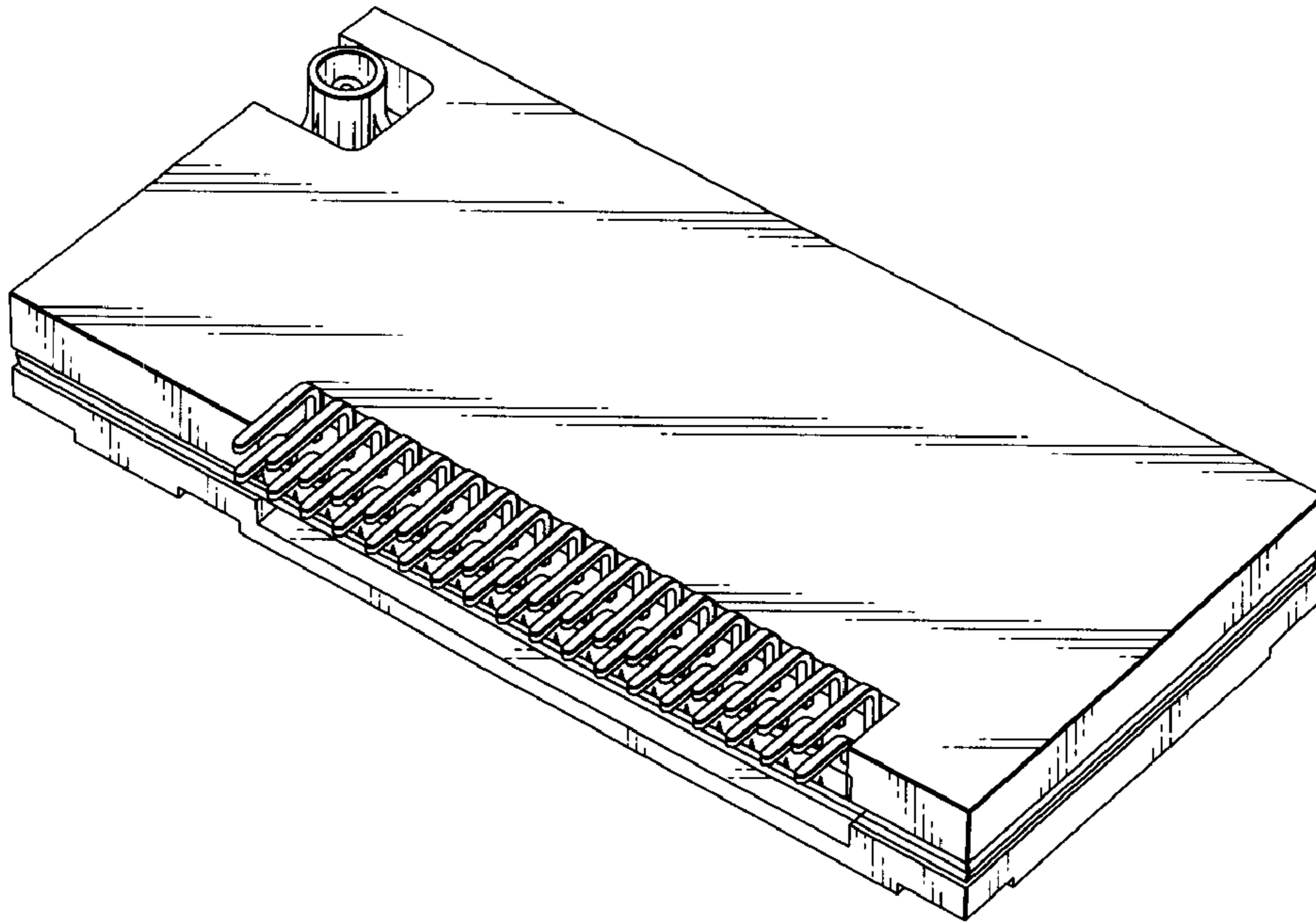

FIG.2

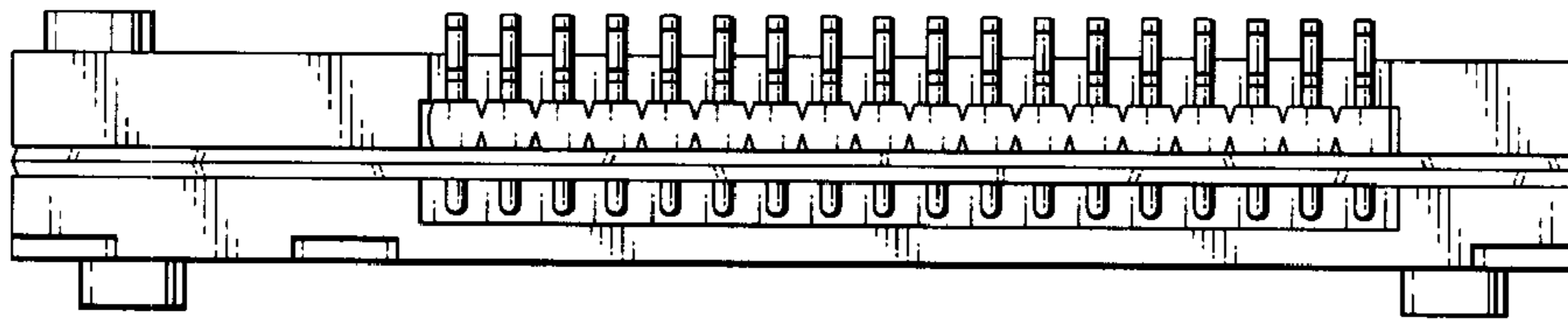

FIG.3

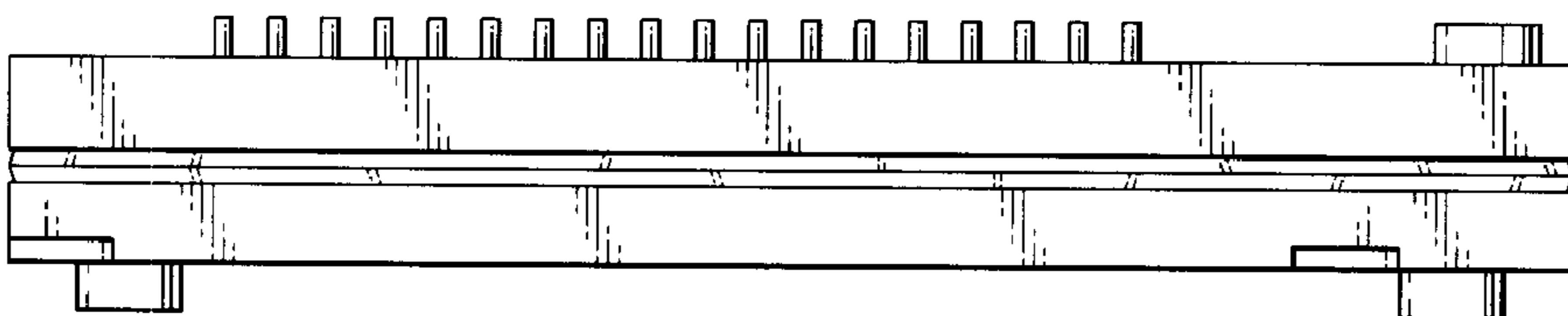

FIG.4

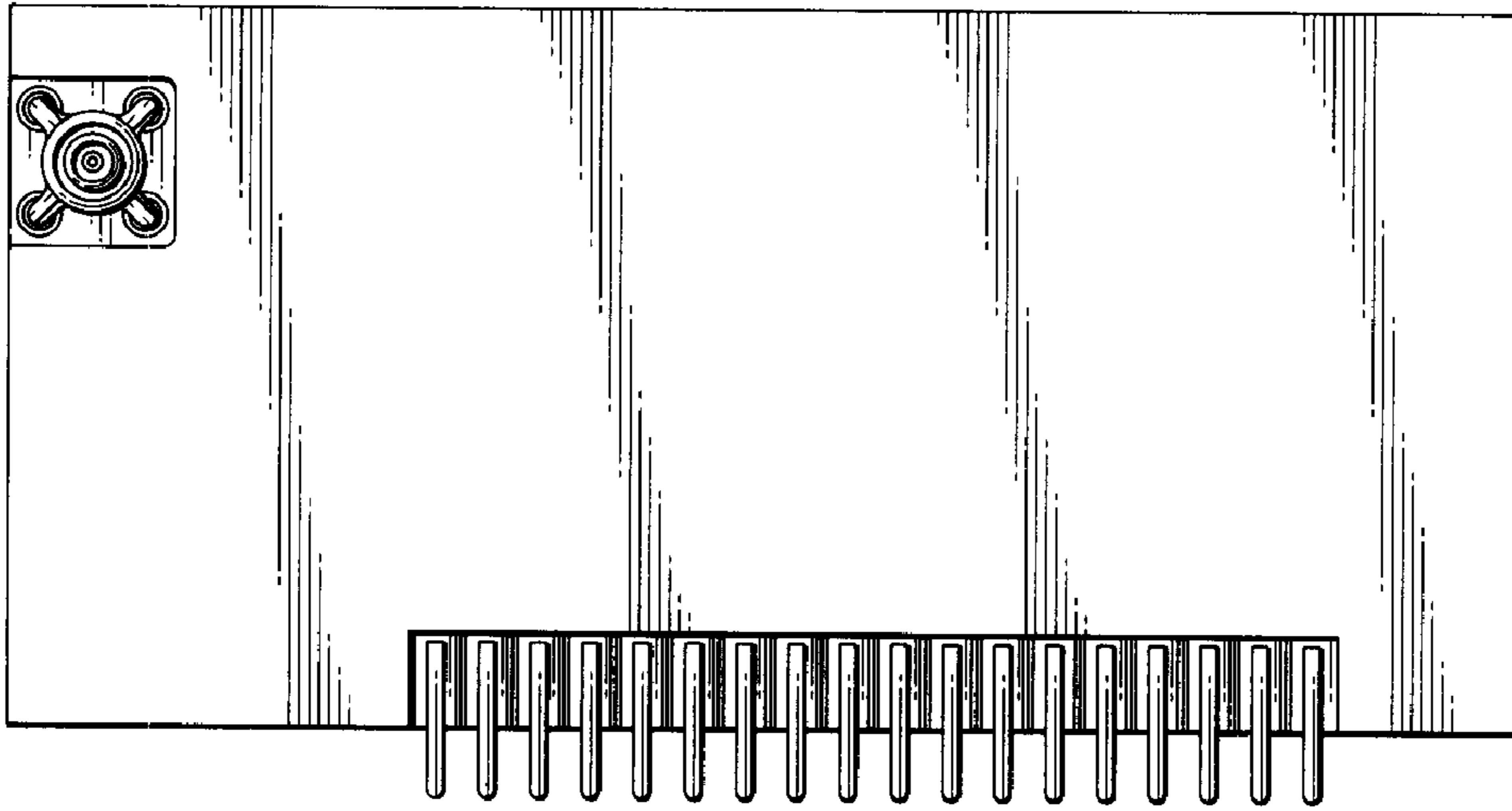

FIG.5

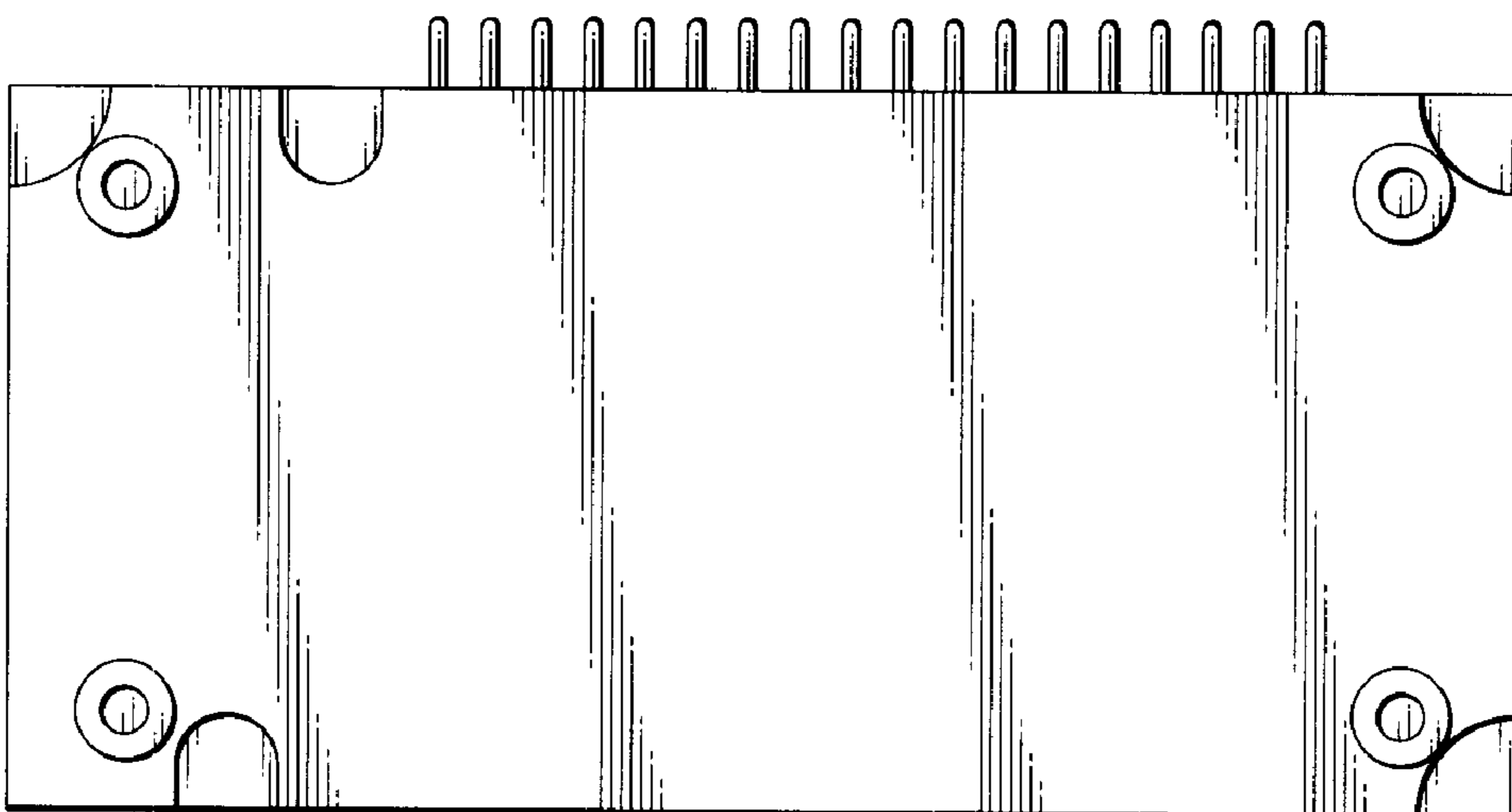

FIG.6

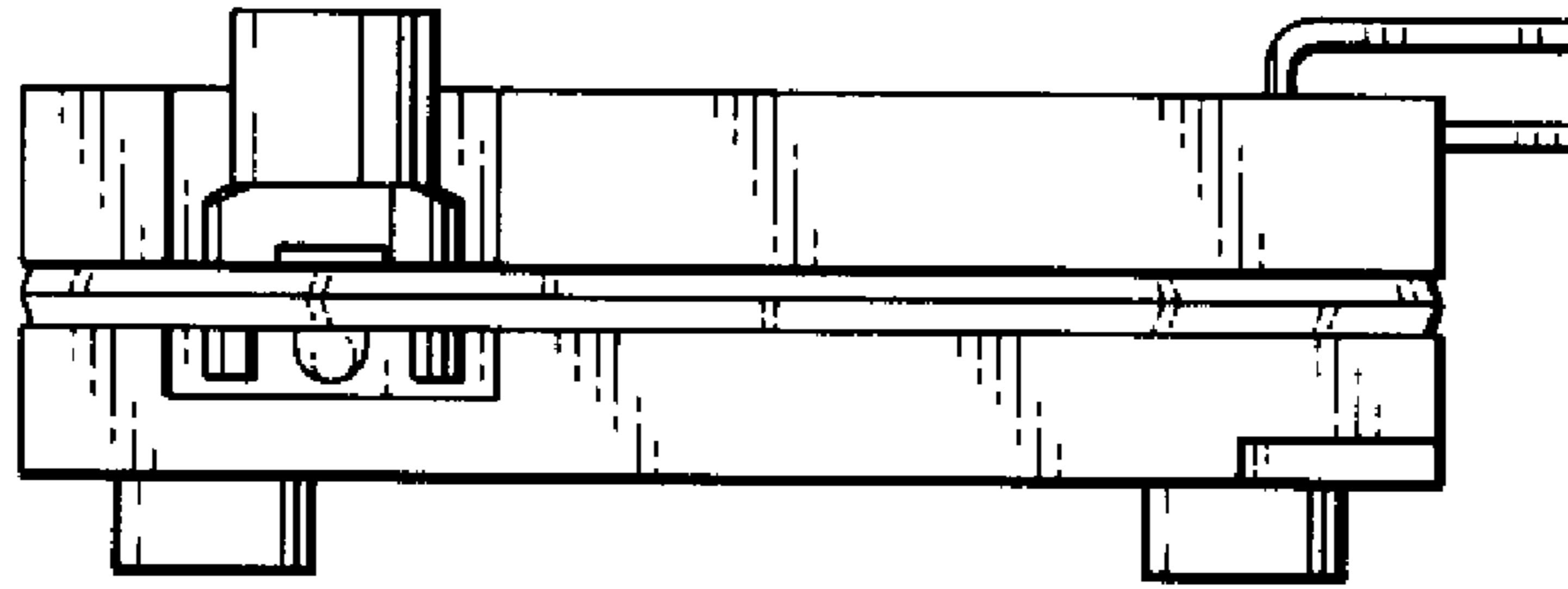

FIG.7

