



US00D533497S

(12) **United States Design Patent**
Templeman

(10) **Patent No.:** **US D533,497 S**

(45) **Date of Patent:** **** Dec. 12, 2006**

(54) **BOAT STABILIZER**

(75) **Inventor:** **Jon C. Templeman**, Overland Park, KS
(US)

(73) **Assignee:** **Marine Dynamics, Inc.**, Lenexa, KS
(US)

(**) **Term:** **14 Years**

(21) **Appl. No.:** **29/193,315**

(22) **Filed:** **Nov. 7, 2003**

(51) **LOC (8) Cl.** **12-06**

(52) **U.S. Cl.** **D12/317**

(58) **Field of Classification Search** D12/230.26,
D12/300, 317; 440/66, 51, 42; 114/274, 284,
114/280, 281, 285-287, 125, 126
See application file for complete search history.

(56) **References Cited**

U.S. PATENT DOCUMENTS

D308,851 S 6/1990 Templeman
D311,513 S 10/1990 Templeman

5,048,449 A 9/1991 Templeman
5,107,786 A 4/1992 Templeman
D331,738 S * 12/1992 Simpson D12/317
D351,129 S * 10/1994 Templeman D12/317
D363,914 S * 11/1995 Corn D12/317

* cited by examiner

Primary Examiner—Holly Baynham

Assistant Examiner—Cynthia M. Chin

(74) *Attorney, Agent, or Firm*—McAfee & Taft

(57) **CLAIM**

The ornamental design for an boat stabilizer, as shown.

DESCRIPTION

FIG. 1 is an enlarged perspective view of the boat stabilizer, showing my new design;
FIG. 2 is a top plan view thereof;
FIG. 3 is a bottom plan view thereof;
FIG. 4 is a left side elevational view thereof;
FIG. 5 is a right side elevational view thereof;
FIG. 6 is a front elevational view thereof; and,
FIG. 7 is a rear elevational view thereof.

1 Claim, 3 Drawing Sheets

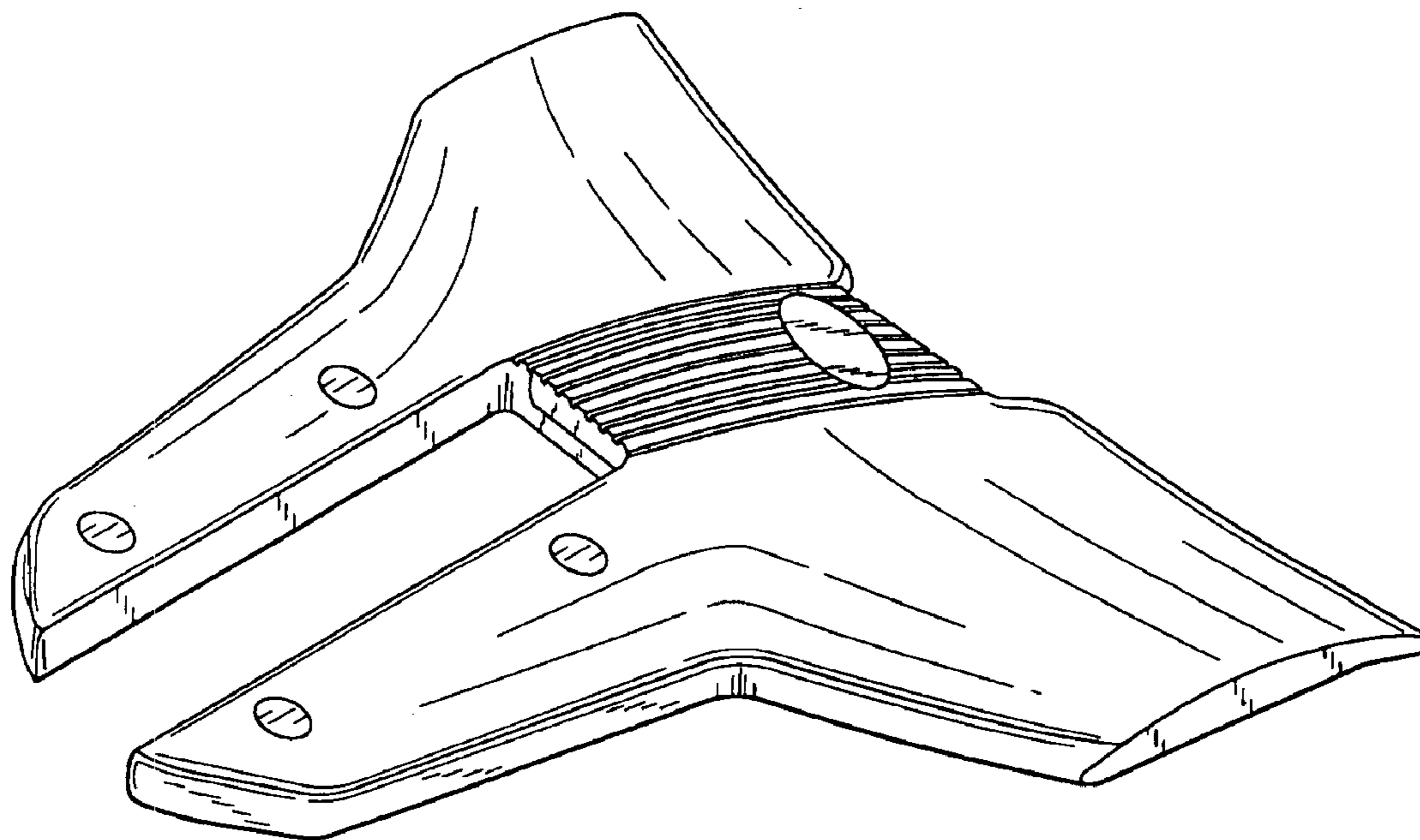

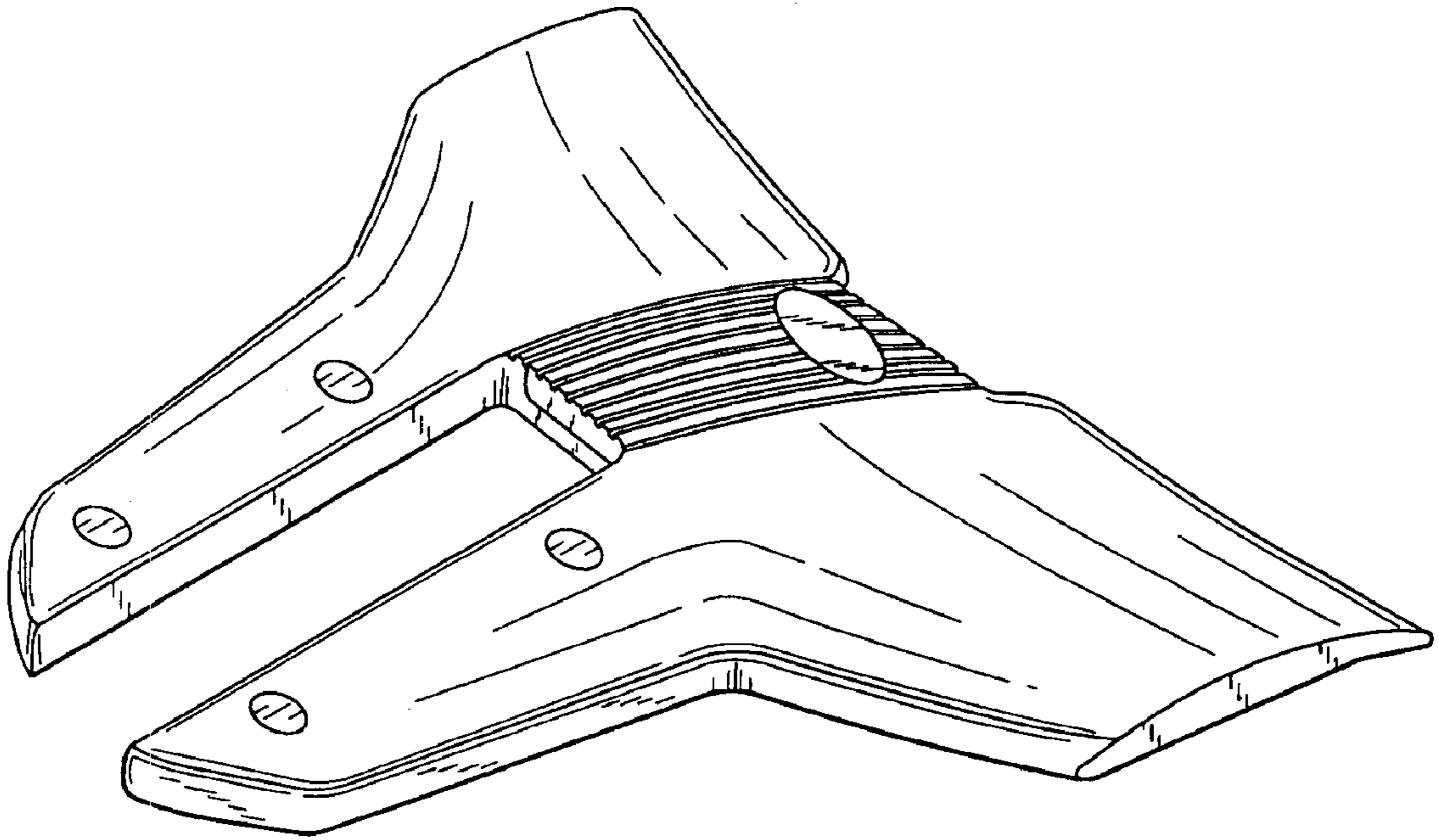

FIG. 1

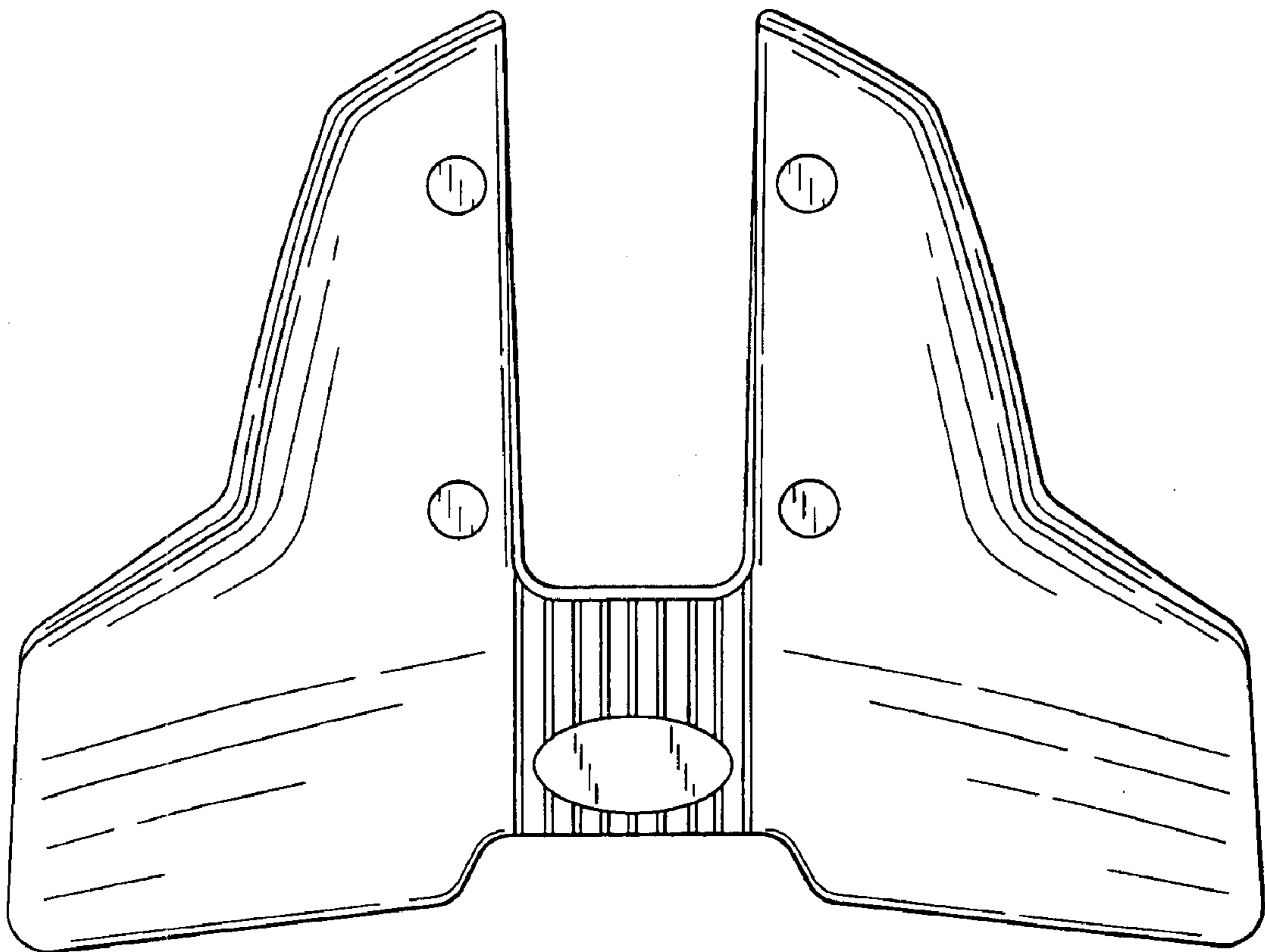

FIG. 2

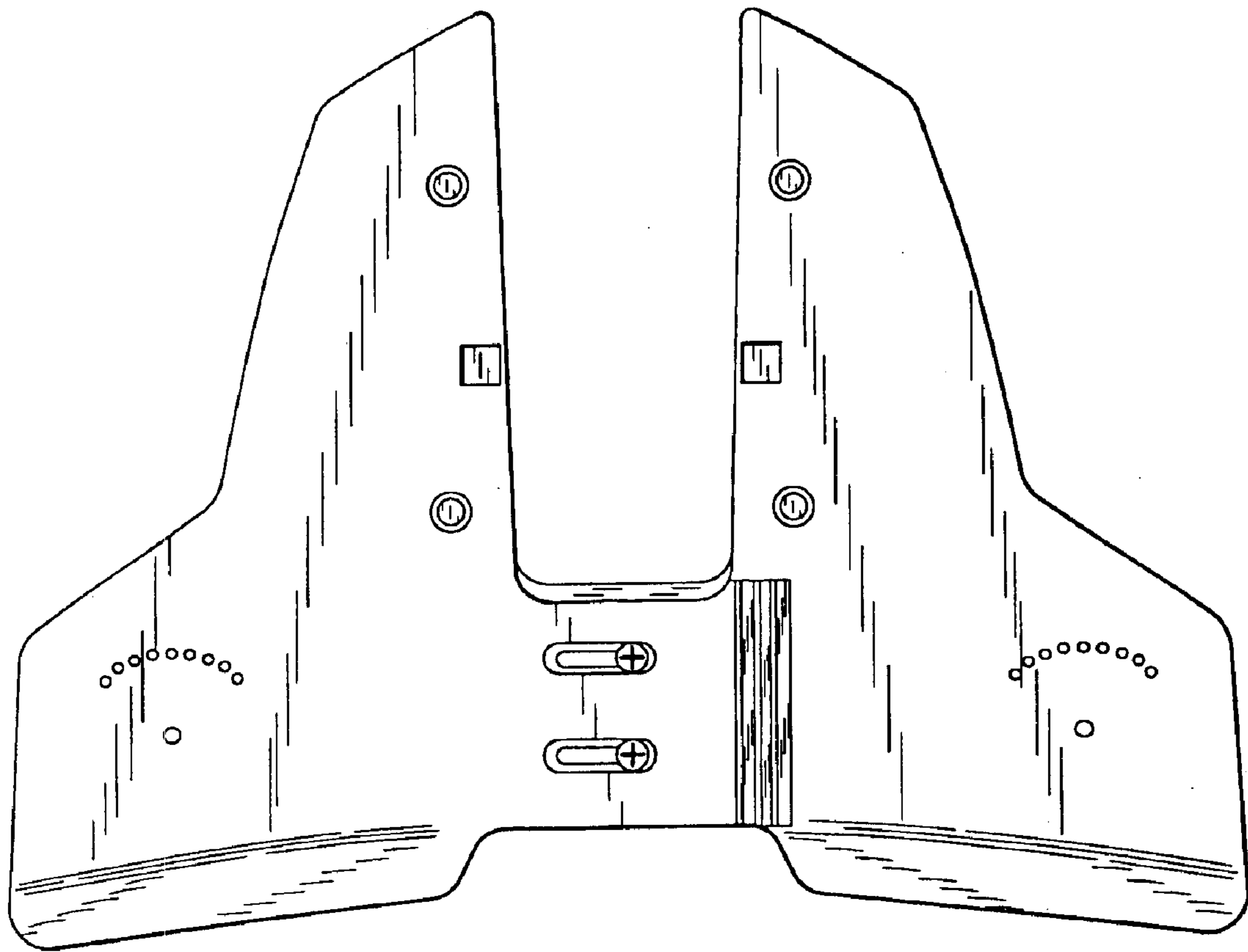

FIG. 1

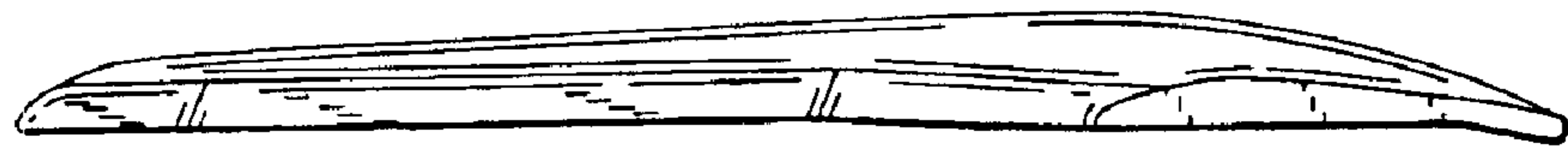

FIG. 2

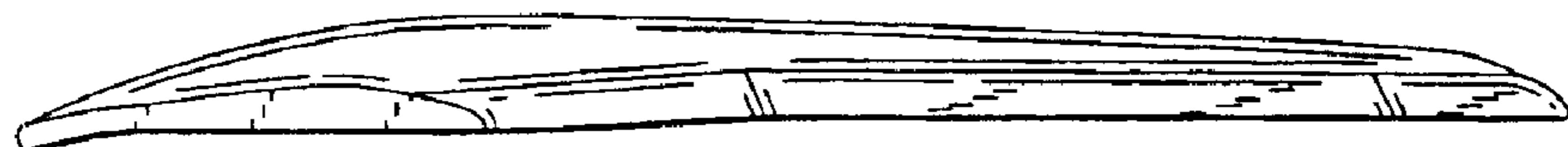

FIG. 3

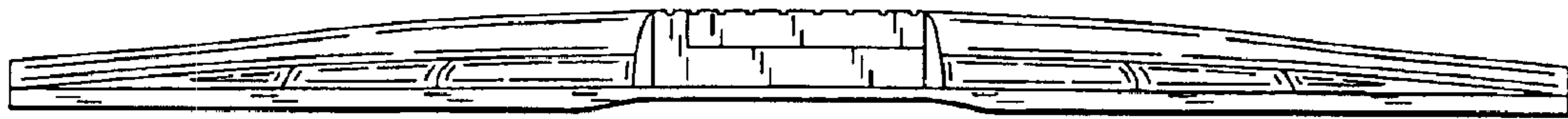

FIG. 6



FIG. 7