



US00D533326S

(12) **United States Design Patent** (10) **Patent No.:** **US D533,326 S**
Sugai (45) **Date of Patent:** **** Dec. 5, 2006**

(54) **GOLF CART**

(75) Inventor: **Katsumi Sugai**, Nagoya (JP)

(73) Assignee: **Sugai General Industries, Ltd.**,
Aichi-ken (JP)

(**) Term: **14 Years**

(21) Appl. No.: **29/212,078**

(22) Filed: **Aug. 26, 2004**

(30) **Foreign Application Priority Data**

Jun. 7, 2004 (JP) 2004-016877

(51) **LOC (8) Cl.** **12-13**

(52) **U.S. Cl.** **D34/15**

(58) **Field of Classification Search** D34/12-27;
D12/1, 2, 16, 129, 91; 180/19.1-19.3, 191,
180/6.5; 280/645, 652, 641, 654, 655; 224/274;
D21/425, 433; 296/77.1, 102, 26.1, 79; 248/96,
248/452

See application file for complete search history.

(56) **References Cited**

U.S. PATENT DOCUMENTS

- D236,098 S * 7/1975 Bedel D12/16
- D271,008 S * 10/1983 Saporito D12/16
- 4,773,695 A * 9/1988 Jones et al. 296/77.1
- 5,083,736 A * 1/1992 McCoy 248/452
- 5,094,500 A * 3/1992 Maypole et al. 296/102
- D326,831 S * 6/1992 Lanius et al. D12/16
- D345,717 S * 4/1994 Molzon et al. D12/16
- D345,718 S * 4/1994 Molzon et al. D12/16

- D369,762 S * 5/1996 Molzon et al. D12/16
- D373,099 S * 8/1996 Molzon et al. D12/16
- D432,460 S * 10/2000 Huang D12/16
- D433,651 S * 11/2000 Matsumura et al. D12/1
- 6,279,993 B1 * 8/2001 Berthiaume 297/219.1
- 6,322,123 B1 * 11/2001 Garrison et al. 296/26.1
- 6,601,745 B1 * 8/2003 Tyrer 224/274
- D483,079 S * 12/2003 Wang et al. D21/433

FOREIGN PATENT DOCUMENTS

JP D 1068737 2/2000

* cited by examiner

Primary Examiner—Freda Nunn

Assistant Examiner—Kevin K. Rudzinski

(74) *Attorney, Agent, or Firm*—Hamre, Schumann, Mueller
& Larson, P.C.

(57) **CLAIM**

I claim the ornamental design for a golf cart, as shown and described.

DESCRIPTION

FIG. 1 is a front view of a golf cart showing my new design; FIG. 2 is a right side view of the same, the left side view being symmetrical to the right side view; FIG. 3 is a top plan view of the same; FIG. 4 is a bottom view of the same; FIG. 5 is a rear view of the same; and, FIG. 6 is a perspective view of the same, wherein the broken line showing of environmental structure is for illustrative purposes only and forms no part of the claimed design.

1 Claim, 3 Drawing Sheets

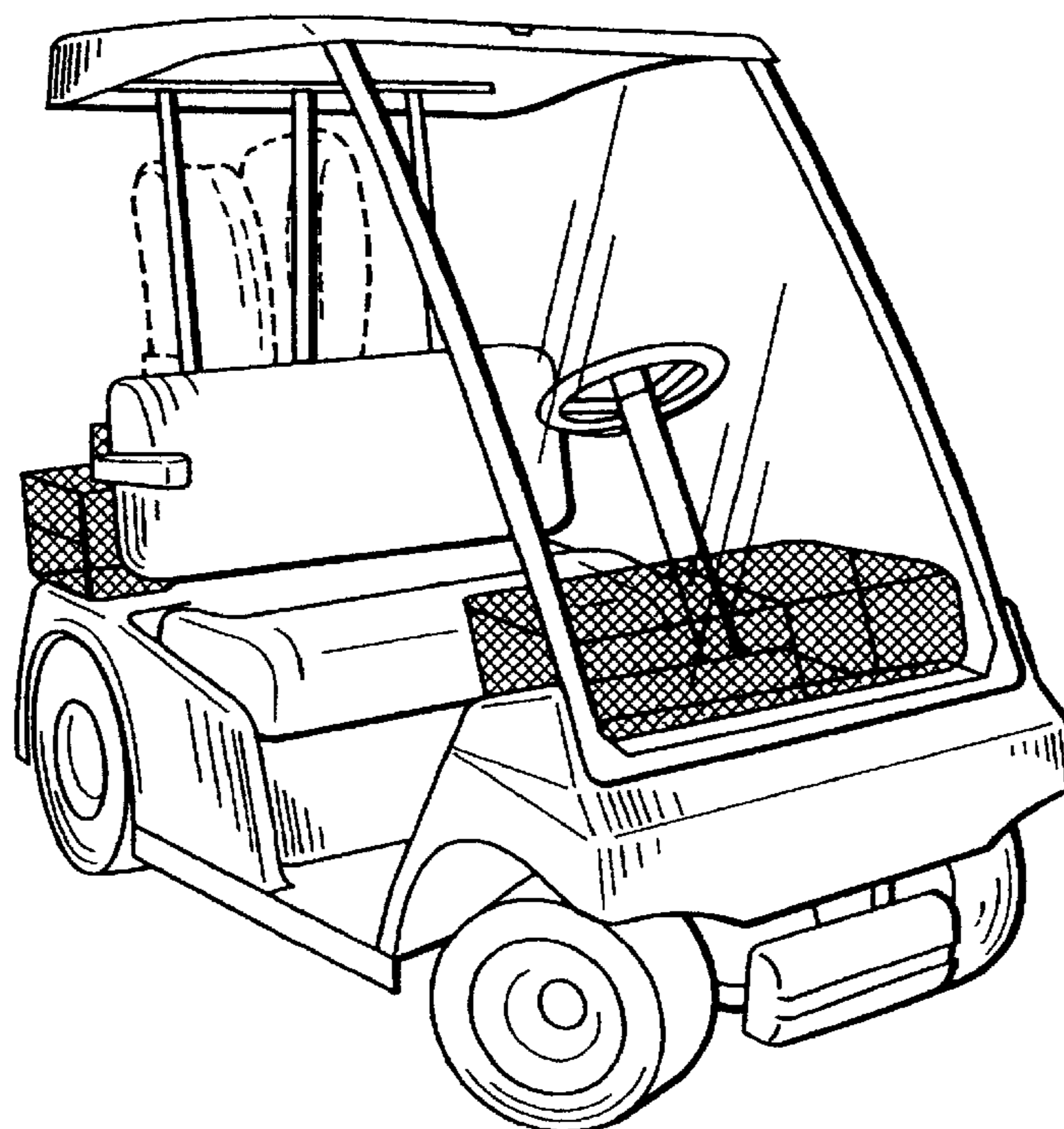

FIG. 1

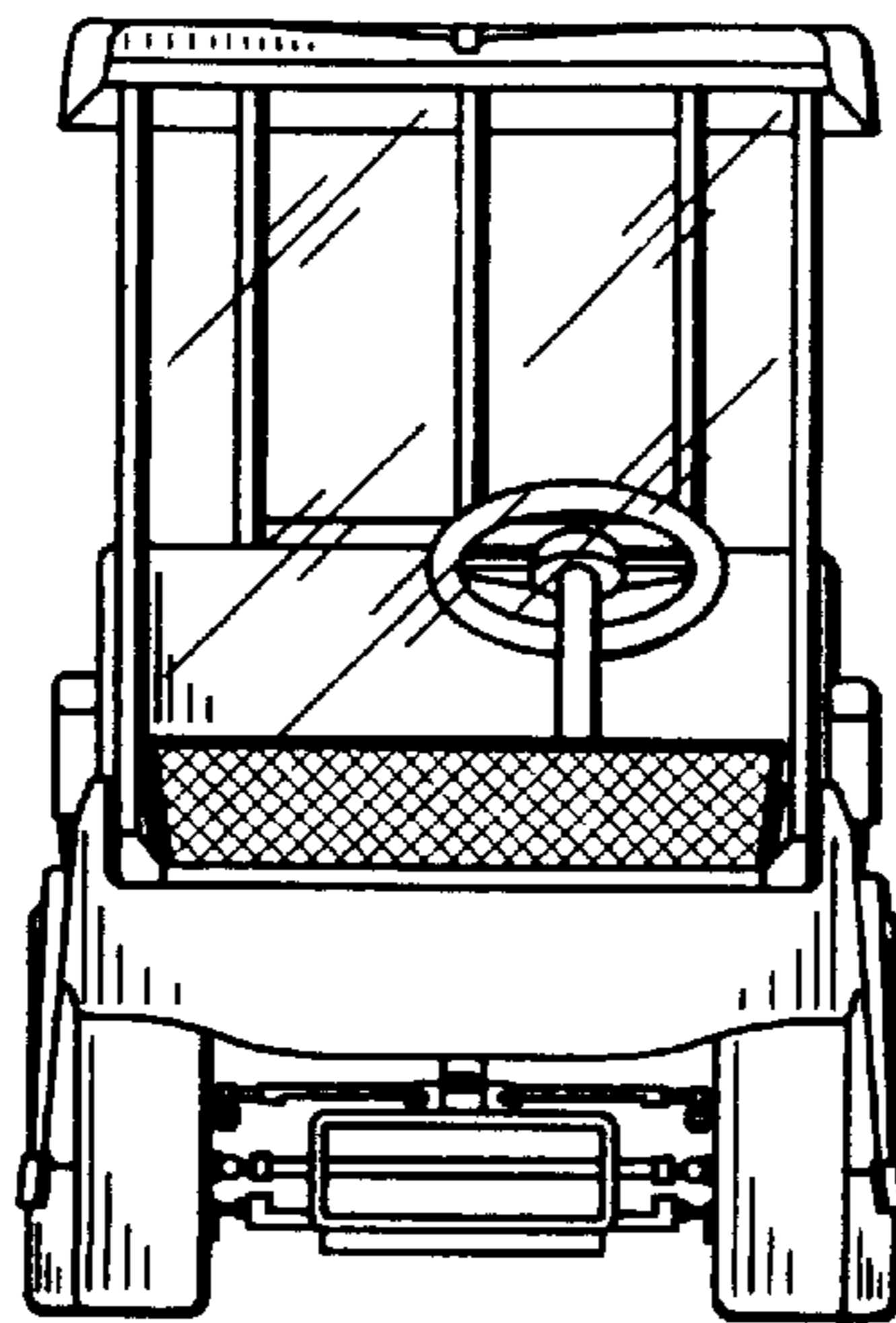

FIG. 2

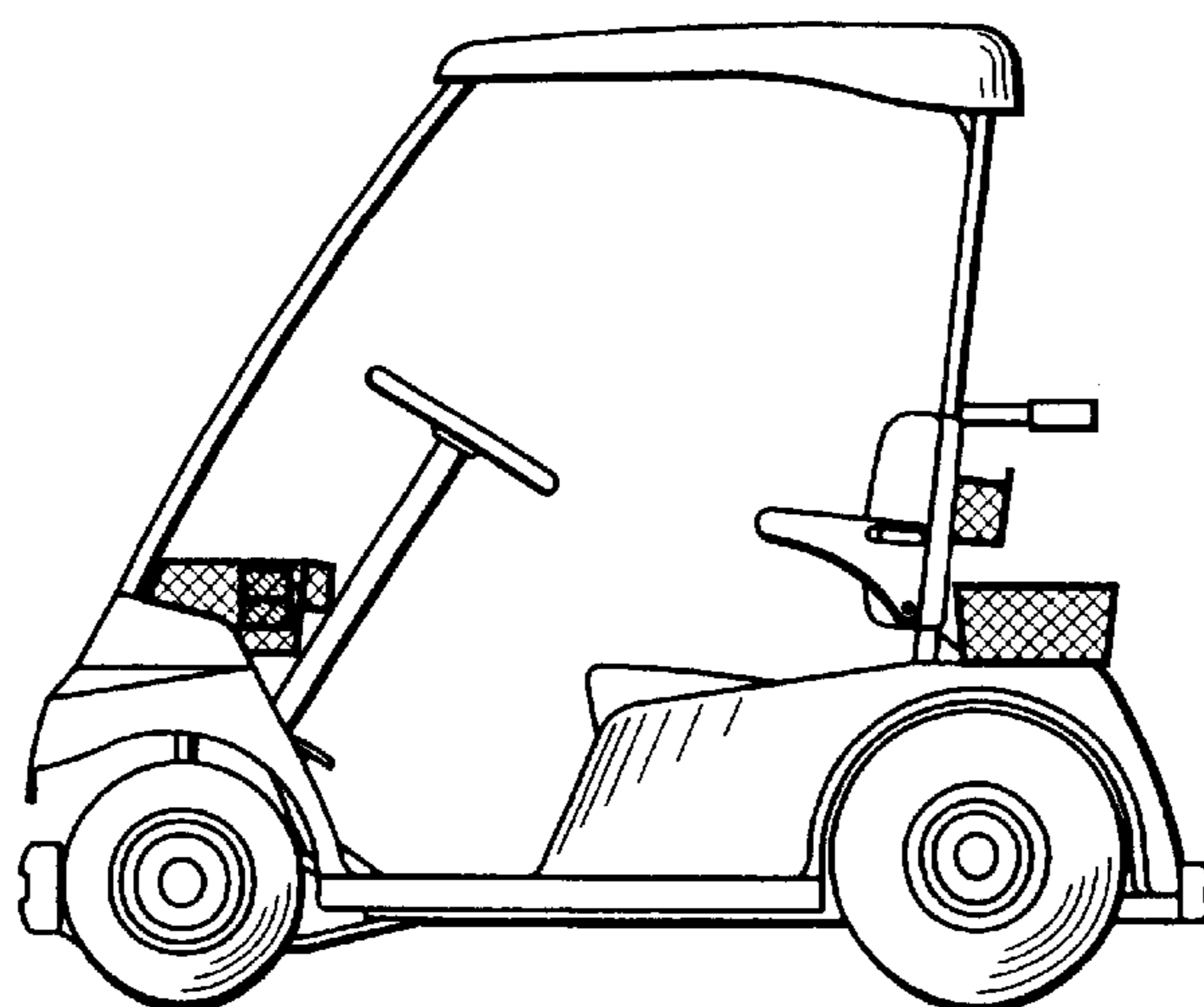

FIG. 3

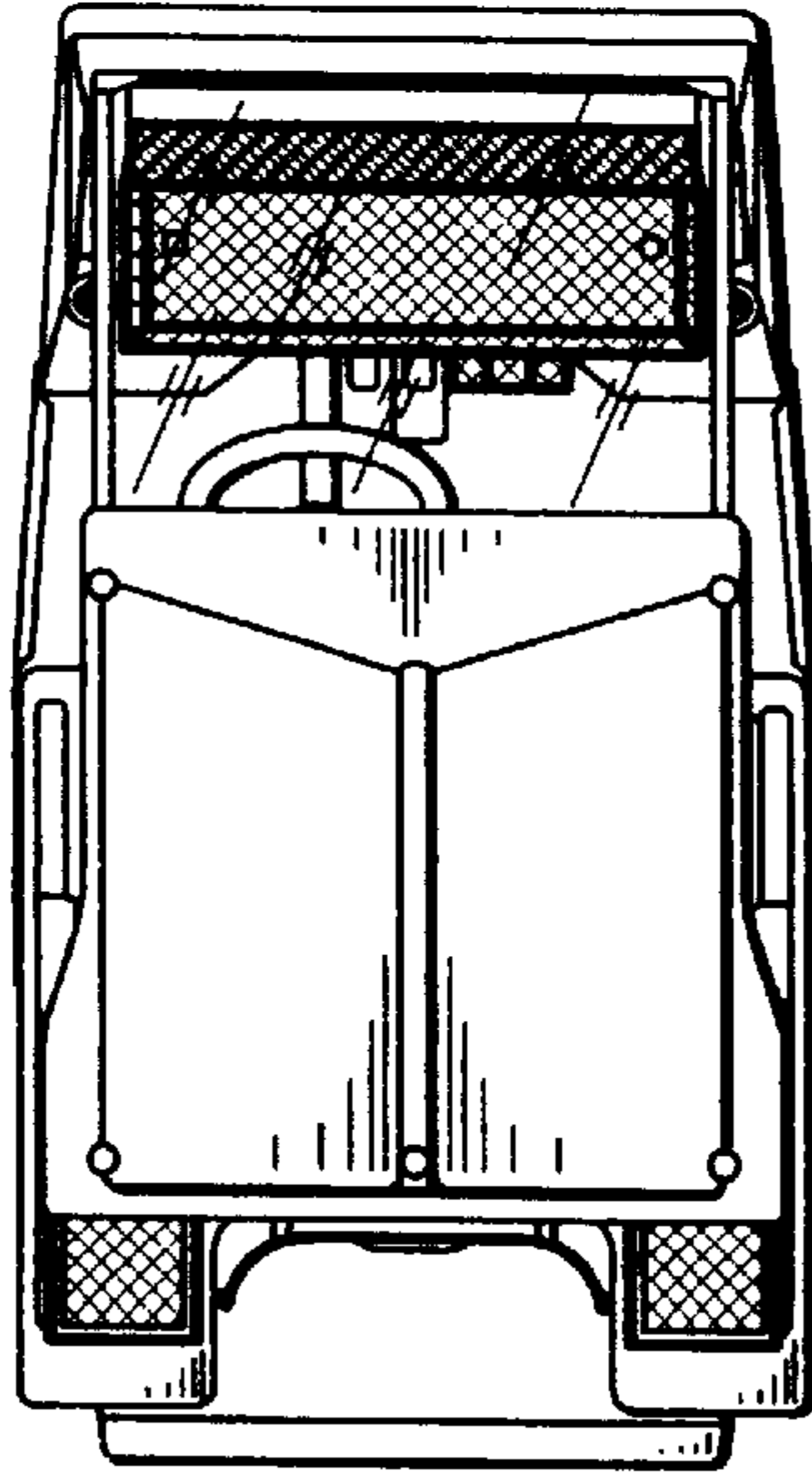

FIG. 4

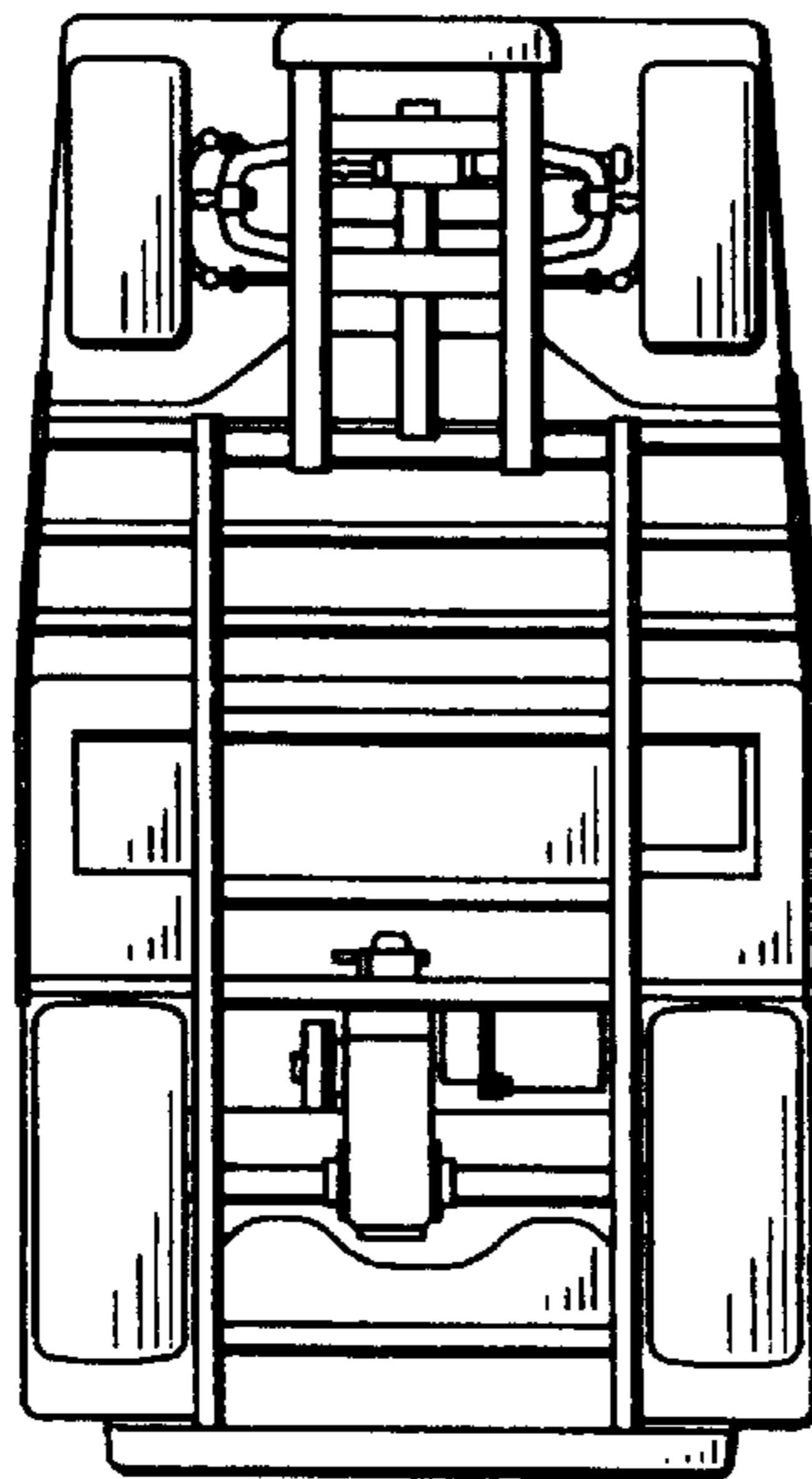

FIG. 5

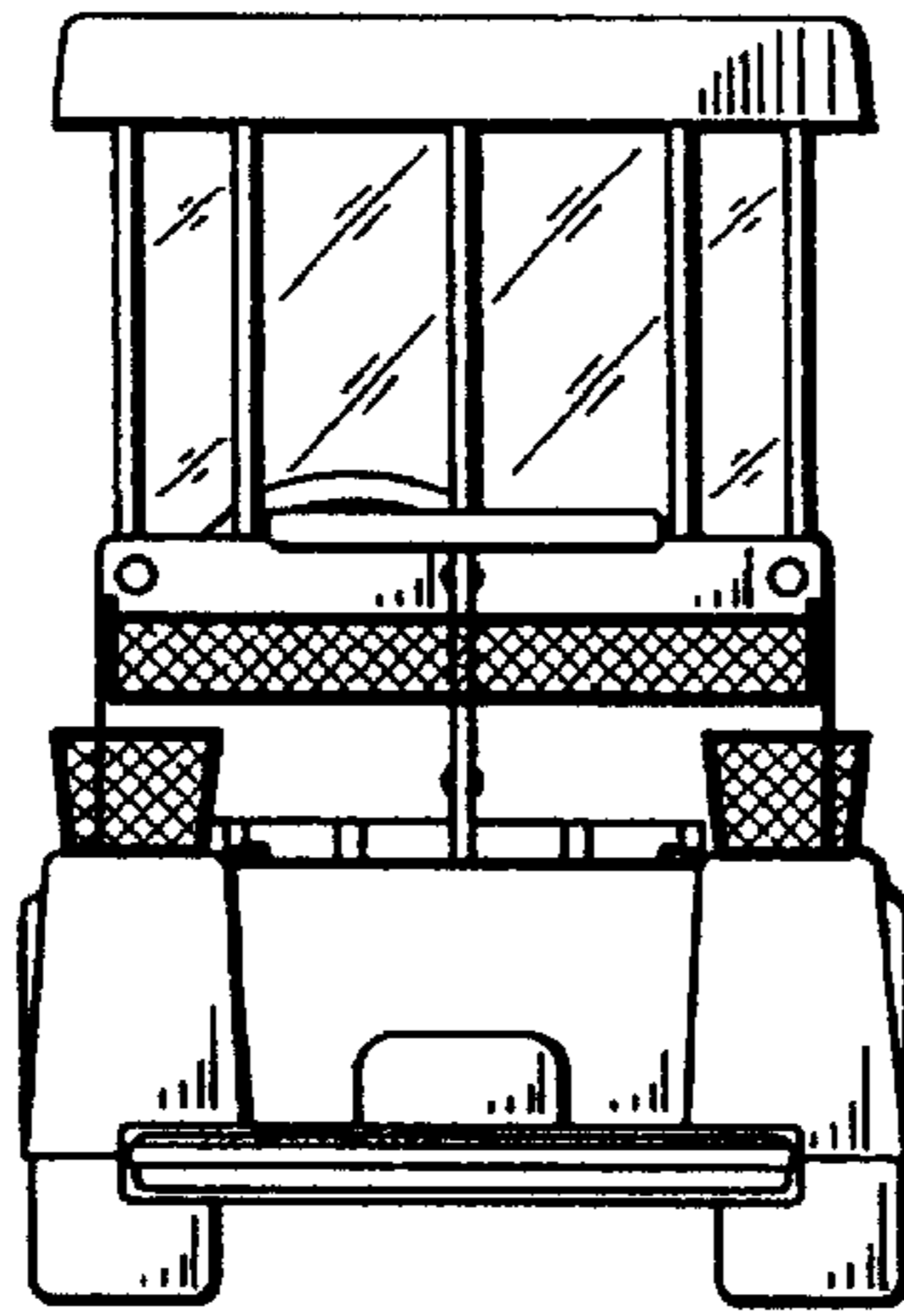

FIG. 6

