



US00D533096S

(12) **United States Design Patent**  
**Phillips**

(10) **Patent No.:** **US D533,096 S**

(45) **Date of Patent:** **\*\* Dec. 5, 2006**

(54) **GAS PRESSURE GAUGE**

(76) Inventor: **Maurice Phillips**, 89 Lott St.,  
Brooklyn, NY (US) 11226

(\*\*) Term: **14 Years**

(21) Appl. No.: **29/226,274**

(22) Filed: **Mar. 28, 2005**

(51) **LOC (8) Cl.** ..... **10-04**

(52) **U.S. Cl.** ..... **D10/85**

(58) **Field of Classification Search** ..... D10/85;  
73/1.16, 37, 49.1, 49.5, 49.8, 700-756, 861.52,  
73/861.61; 137/14, 557; 285/148.1  
See application file for complete search history.

(56) **References Cited**

U.S. PATENT DOCUMENTS

2,270,371	A	*	1/1942	Frazier	.....	285/148.1
2,902,271	A		9/1959	Clevenger		
4,524,617	A		6/1985	Krehel		
D283,988	S		5/1986	Kaniwec		
D291,231	S	*	8/1987	Datta	.....	D10/85
4,976,134	A	*	12/1990	Potvin	.....	73/1.16
5,186,159	A		2/1993	Crow, Jr.		
5,483,838	A	*	1/1996	Holden	.....	73/861.61
5,555,764	A		9/1996	Dybas		
5,652,391	A	*	7/1997	Kingsford et al.	.....	73/706
5,786,538	A	*	7/1998	Barone	.....	73/714
5,947,372	A		9/1999	Tiernan		
5,983,706	A	*	11/1999	Marks et al.	.....	73/37

6,038,929	A	*	3/2000	Smith	.....	73/756
6,318,407	B1	*	11/2001	Kohn et al.	.....	137/557
6,520,022	B1	*	2/2003	Anderson et al.	.....	73/756
6,530,396	B1	*	3/2003	Frey	.....	137/557
6,644,124	B1	*	11/2003	Huang	.....	73/715
6,925,886	B1	*	8/2005	Meyer	.....	73/732

\* cited by examiner

*Primary Examiner*—Antoine D. Davis

(57) **CLAIM**

The ornamental design for a gas pressure gauge, as shown.

**DESCRIPTION**

A simple mechanical unit with a glass face and analog scale inside the unit that reads in pounds per square inch or the percentage of the remaining fuel. This design is a propane tank accessory and is placed between the tank and the regulator that indicates the current pressure within the tank. Consequently this apparatus enables the user to determine the level of fuel in the propane tank, thereby knowing beforehand the level of fuel in the propane tank.

FIG. 1 is a front perspective view showing my design;

FIG. 2 is a back perspective view;

FIG. 3 is a right side perspective view;

FIG. 4 is a left side perspective view;

FIG. 5 is a bottom perspective view; and,

FIG. 6 is a top perspective view.

Portions of the tube member has been eliminated for ease of illustration.

**1 Claim, 2 Drawing Sheets**

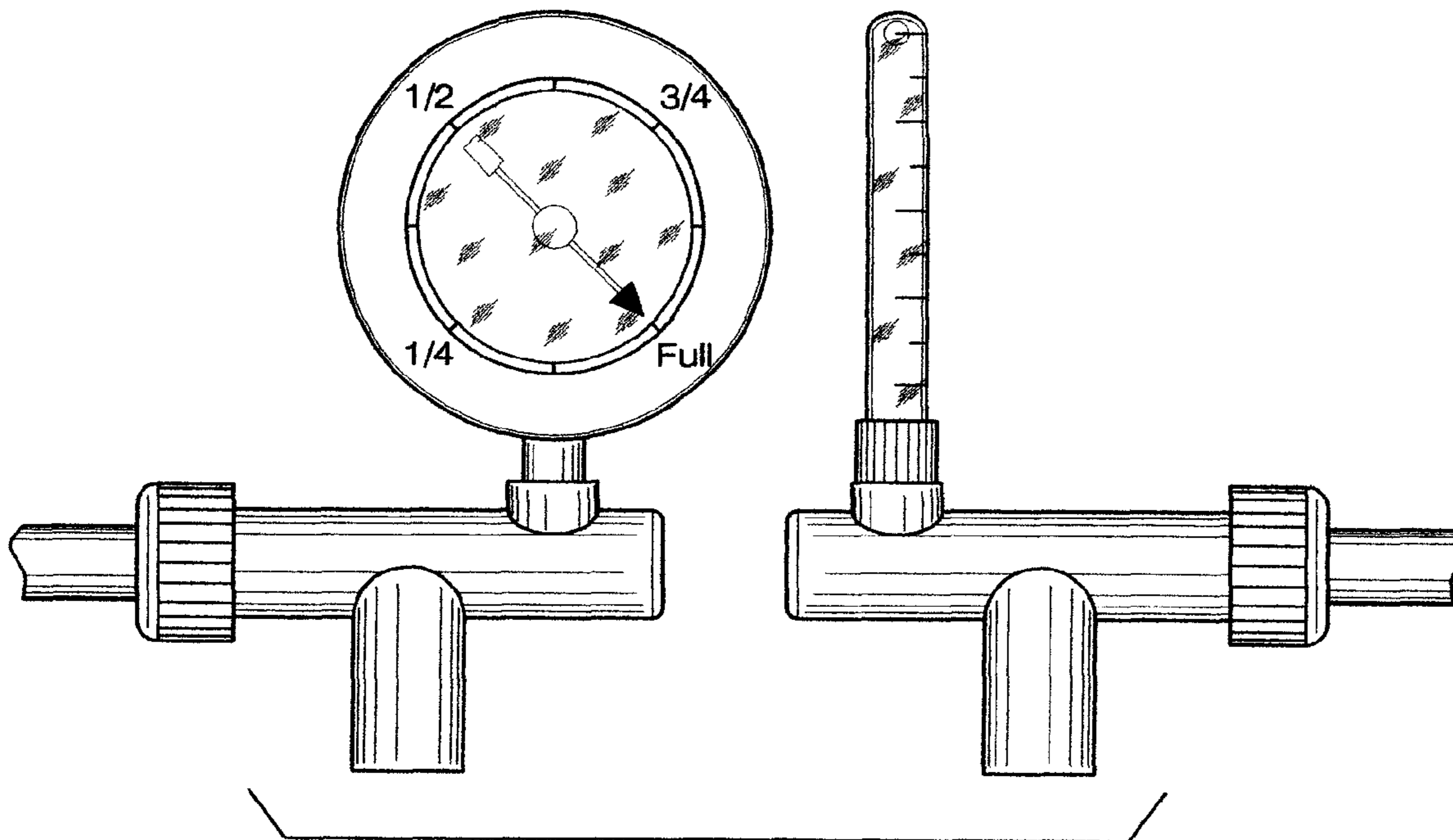

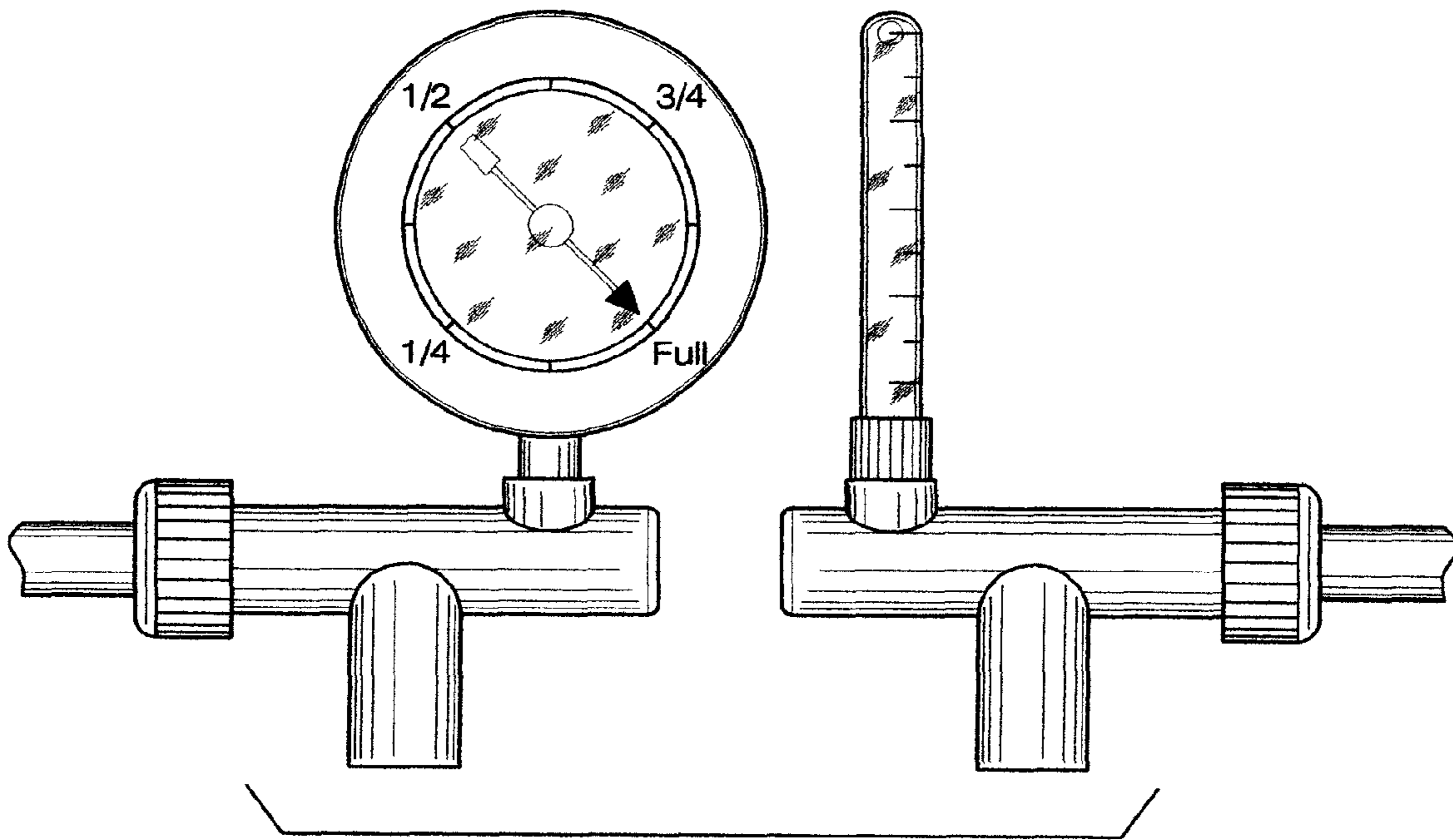

FIG. 1

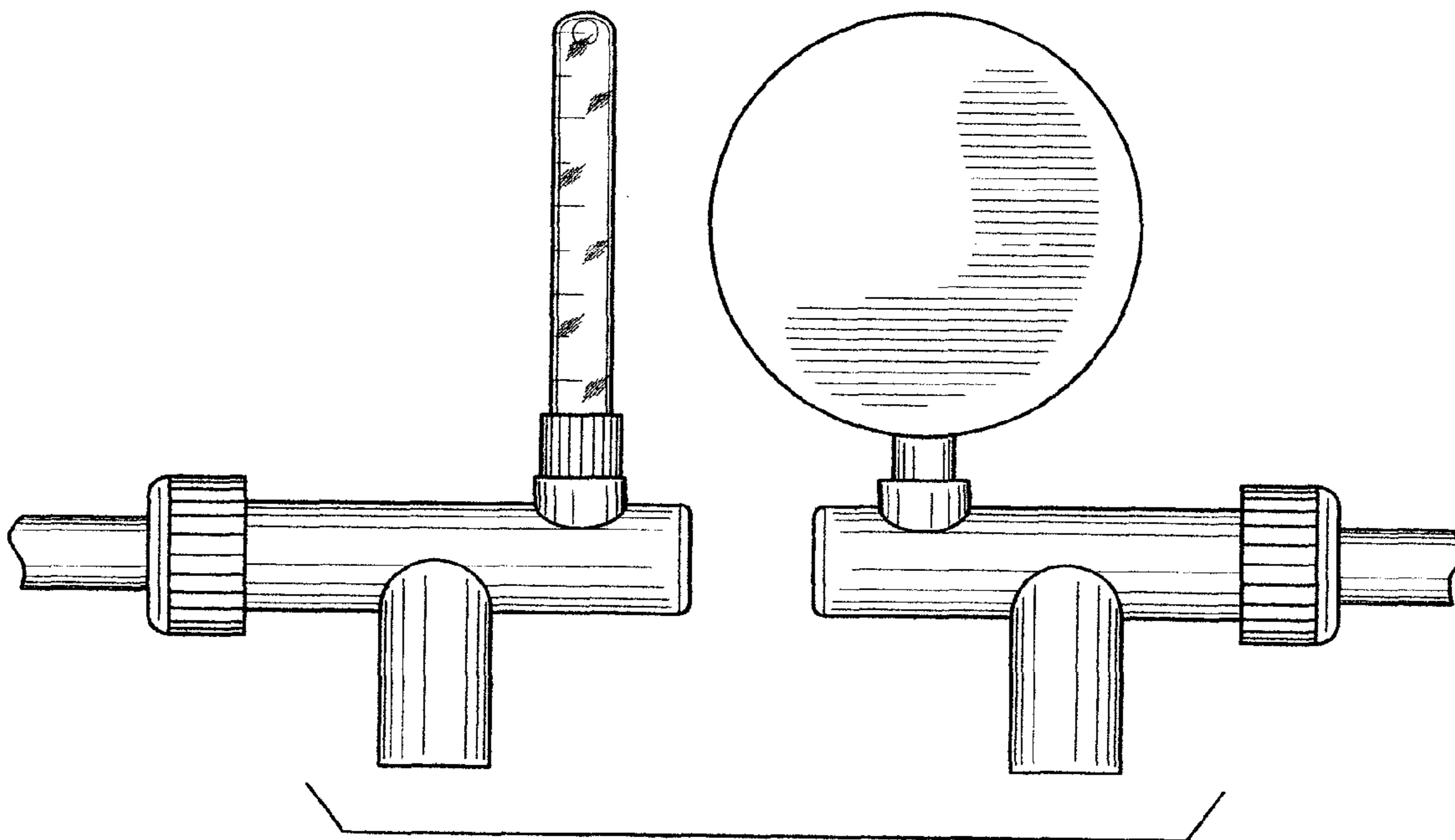

FIG. 2

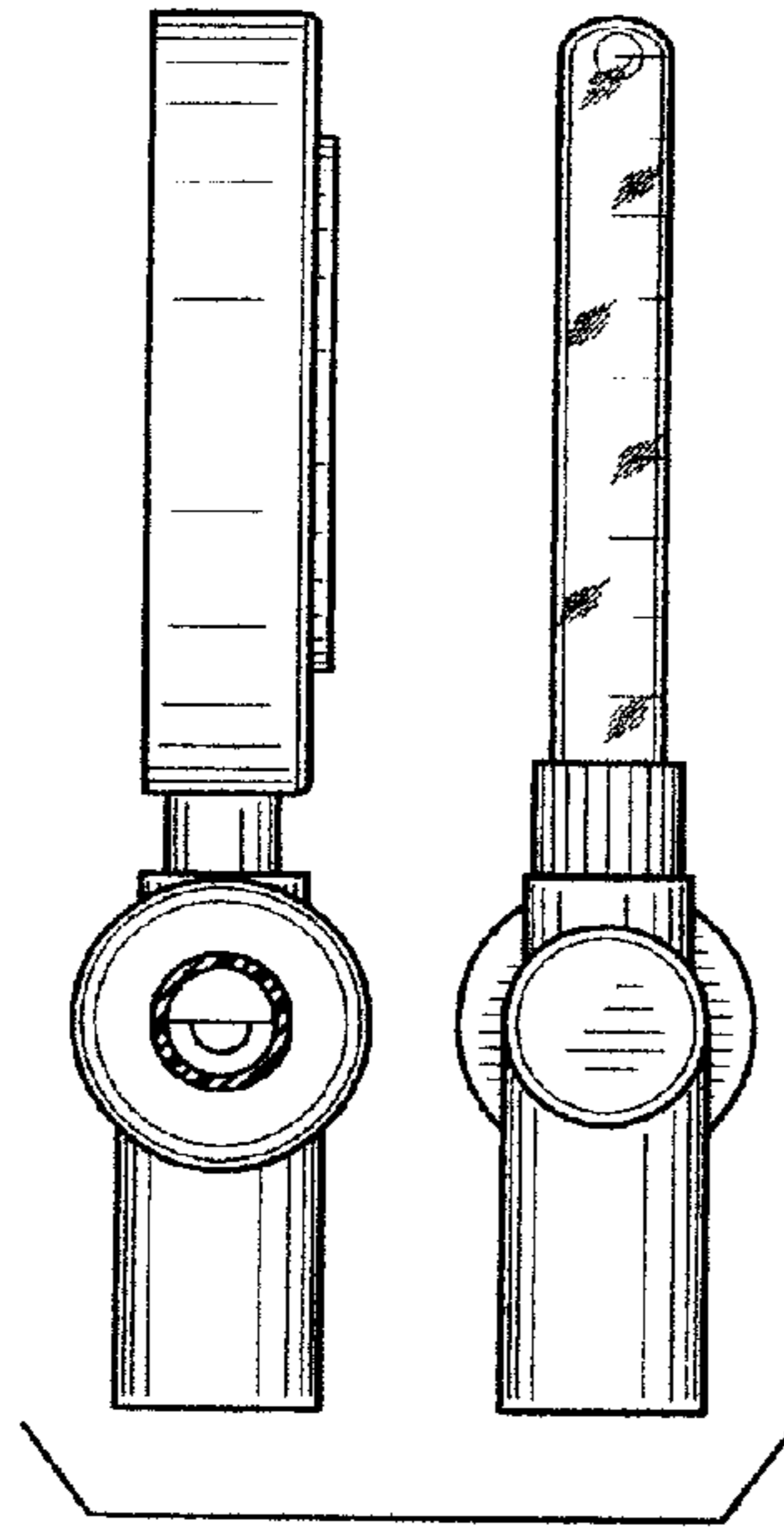

FIG. 3

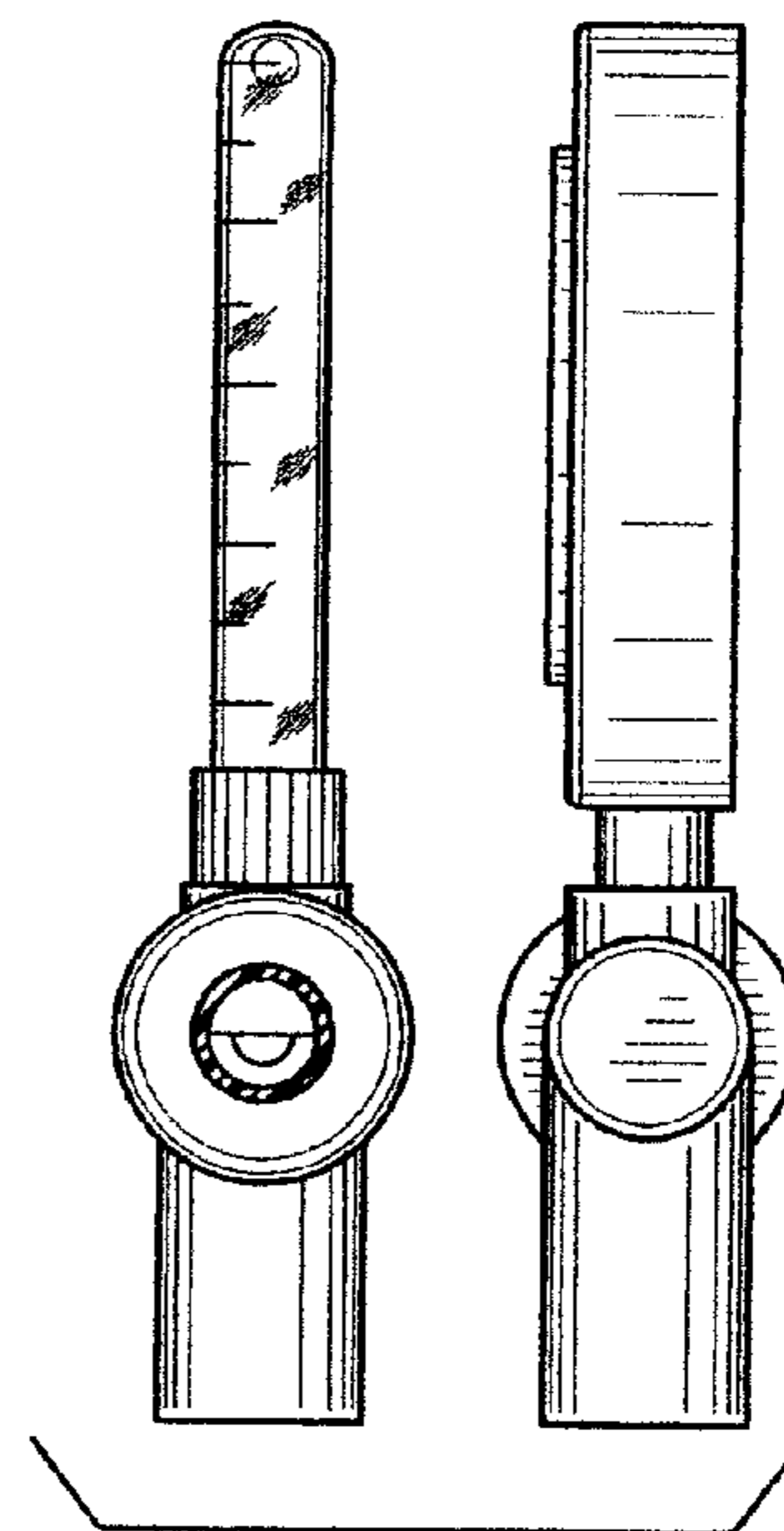

FIG. 4

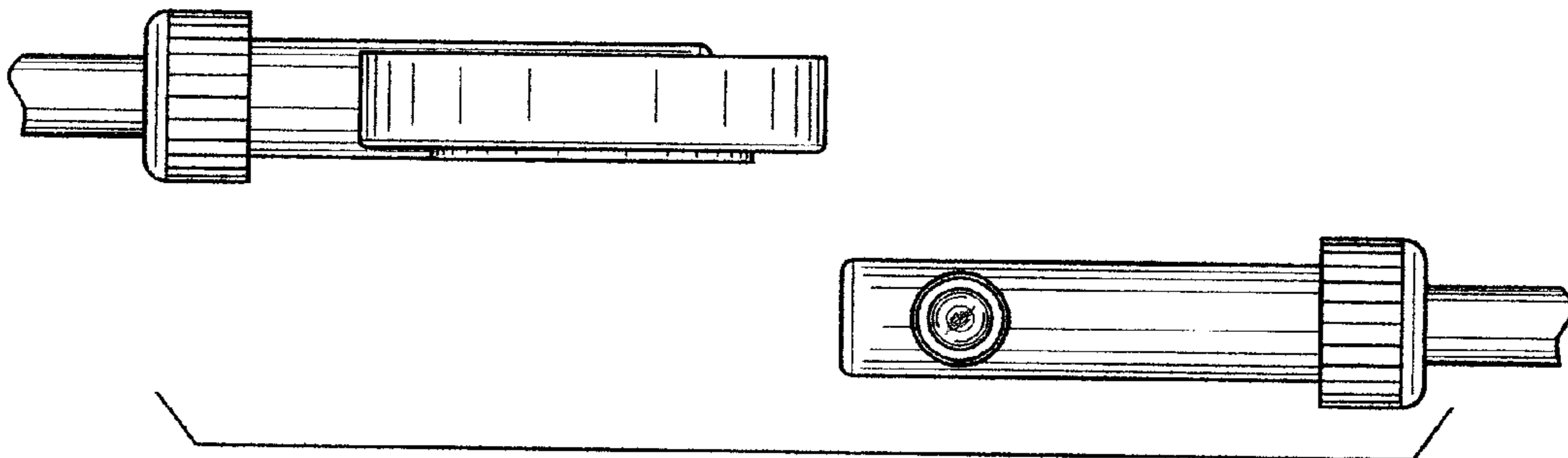

FIG. 5

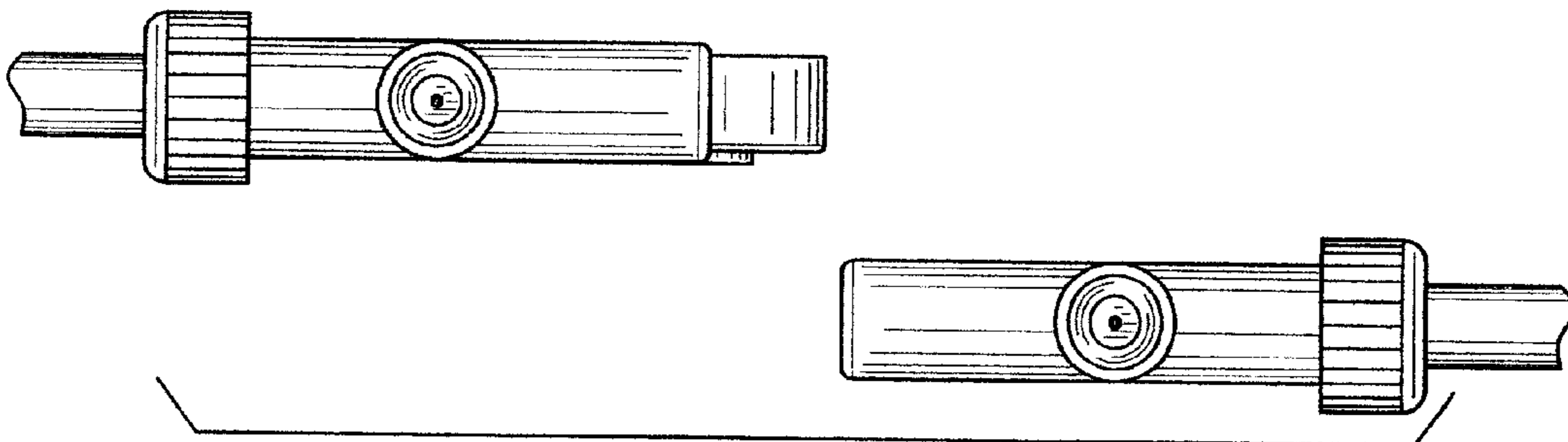

FIG. 6