



US00D532727S

(12) **United States Design Patent** (10) **Patent No.:** **US D532,727 S**
Schiavone et al. (45) **Date of Patent:** **** Nov. 28, 2006**

(54) **VEHICLE GRILLE**

(75) Inventors: **Patrick Schiavone**, Bloomfield, MI (US); **Gordon Platto**, Troy, MI (US); **Michael Smith**, Plymouth, MI (US)

(73) Assignee: **Ford Global Technologies, LLC**, Dearborn, MI (US)

(**) Term: **14 Years**

(21) Appl. No.: **29/246,018**

(22) Filed: **Dec. 21, 2005**

(51) **LOC (8) Cl.** **12-16**

(52) **U.S. Cl.** **D12/169**

(58) **Field of Classification Search** D12/90-92,
D12/86, 169, 196, 163; 296/180.1, 180.2;
293/102, 113, 115, 117, 120
See application file for complete search history.

(56) **References Cited**

U.S. PATENT DOCUMENTS

D494,898 S	*	8/2004	Metros et al.	D12/169
D497,577 S	*	10/2004	Metros et al.	D12/169
D498,444 S	*	11/2004	Mays et al.	D12/169
D503,135 S	*	3/2005	Metros et al.	D12/169
D519,067 S	*	4/2006	Steere et al.	D12/169

OTHER PUBLICATIONS

Pickup Truck.com, *Caught! 2005 Ford F-350 Super Duty*, Aug. 4, 2003 <http://www.pickuptruck.com/html/2005/ford/superduty/caught.html>.

Automotive News Online, *Ford modifies '05 F-series Super Duty pickups*, May 24, 2004 <http://www.autonews.com/article.cms?articleid=48362>.

Detroit News Online, *Ford tests a hydrogen F-350*, Sep. 7, 2004 <http://www.detnews.com/2004/autoinsider/0409/07/b01-265187.htm>.

Detroit News Online, *Ford's Super Duty pickups due for major makeover*, Dec. 22, 2004 <http://info.detnews.com/autosinsider/sneakpeek/index.cfm?id=17263>.

FordForums.com, *US: Spy Shot: 2007 Ford F-Series Super Duty*, Dec. 24, 2004 <http://www.fordforums.com/showthread.php?t=93973>.

Motor Trend's Truck Trend, News Front: *Spied—2007 Super Duty*, p. 16, Mar./Apr. 2005.

CarSpyShots.net, *2007 Ford SuperDutys (f250, f350)*, Jul. 23, 2005 <http://www.carspyshots.net/zerthread?id=16073>.
CarSpyShots.net, *Re: (CD-BP)*, Sep. 1, 2005 <http://www.carspyshots.net/zerthread?id=16073>.

TheCarConnection.com, *Ford Excursion Sinks into History*, Sep. 25, 2005 http://www.thecarconnection.com/Auto_News/Daily_Edition/Daily_Edition_Sept_30%20Oct_3_2005.S173.A9375.html.

The Detroit News (detnews.com), Autos insider: *Out of Gas: Ford's fuel-guzzling Excursion reaches end of line*, Sep. 30, 2005 <http://www.detnews.com/2005/autoinsider/0509/30/C01-332800.htm?r=truckblog.com>.

Edmunds.com, *2007 Ford F250/F350 Large Truck*, date unknown <http://www.edmunds.com/future/2007/ford/f250f350/100491426/preview.html>.

Edmunds.com, *Inside Line: 2005 Excursion*, date unknown <http://www.edmunds.com/insideline/do/ViewModelDetail/make=Ford/model=Excursion>.

Ford Vehicles, *2005 Ford Excursion*, date unknown <http://www.fordvehicles.com/suvs/excursion/>.

* cited by examiner

Primary Examiner—Melody N. Brown

(74) *Attorney, Agent, or Firm*—Damian Porcari

(57) **CLAIM**

The ornamental design for a vehicle grille, as shown and described.

DESCRIPTION

FIG. 1 is a front perspective view of a vehicle grille attached to a vehicle, no part of the vehicle is claimed;

FIG. 2 is a front elevational view of the vehicle grille;

FIG. 3 is a top plan view of the vehicle grille;

FIG. 4 is bottom plan view of the vehicle grille; and,

FIG. 5 is a left side elevational view of the vehicle grille (the right side view is a mirror of the left side view and is not shown).

The broken lines shown throughout the drawing are for illustrative purposes only and form no part of the claimed design.

1 Claim, 5 Drawing Sheets

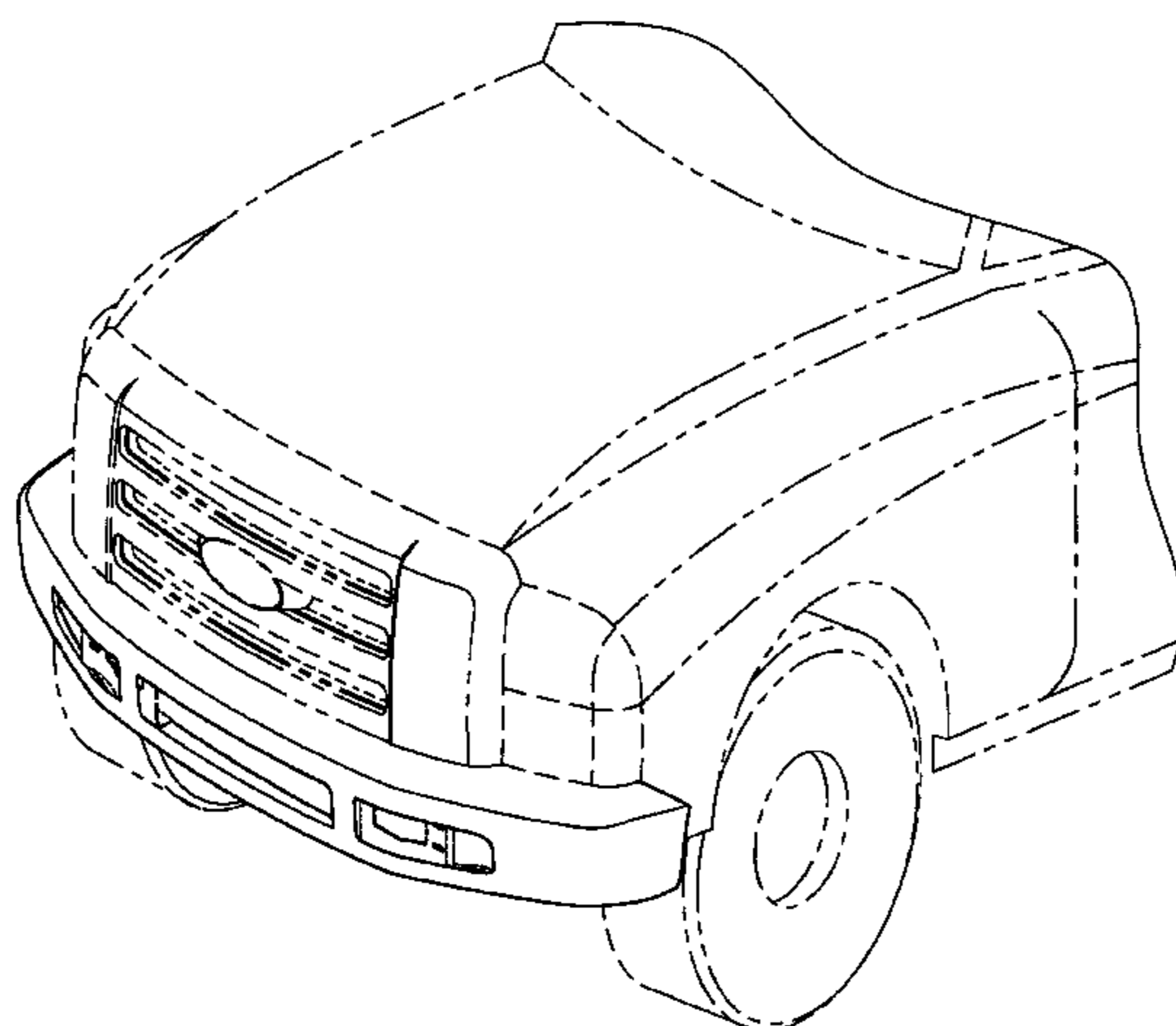

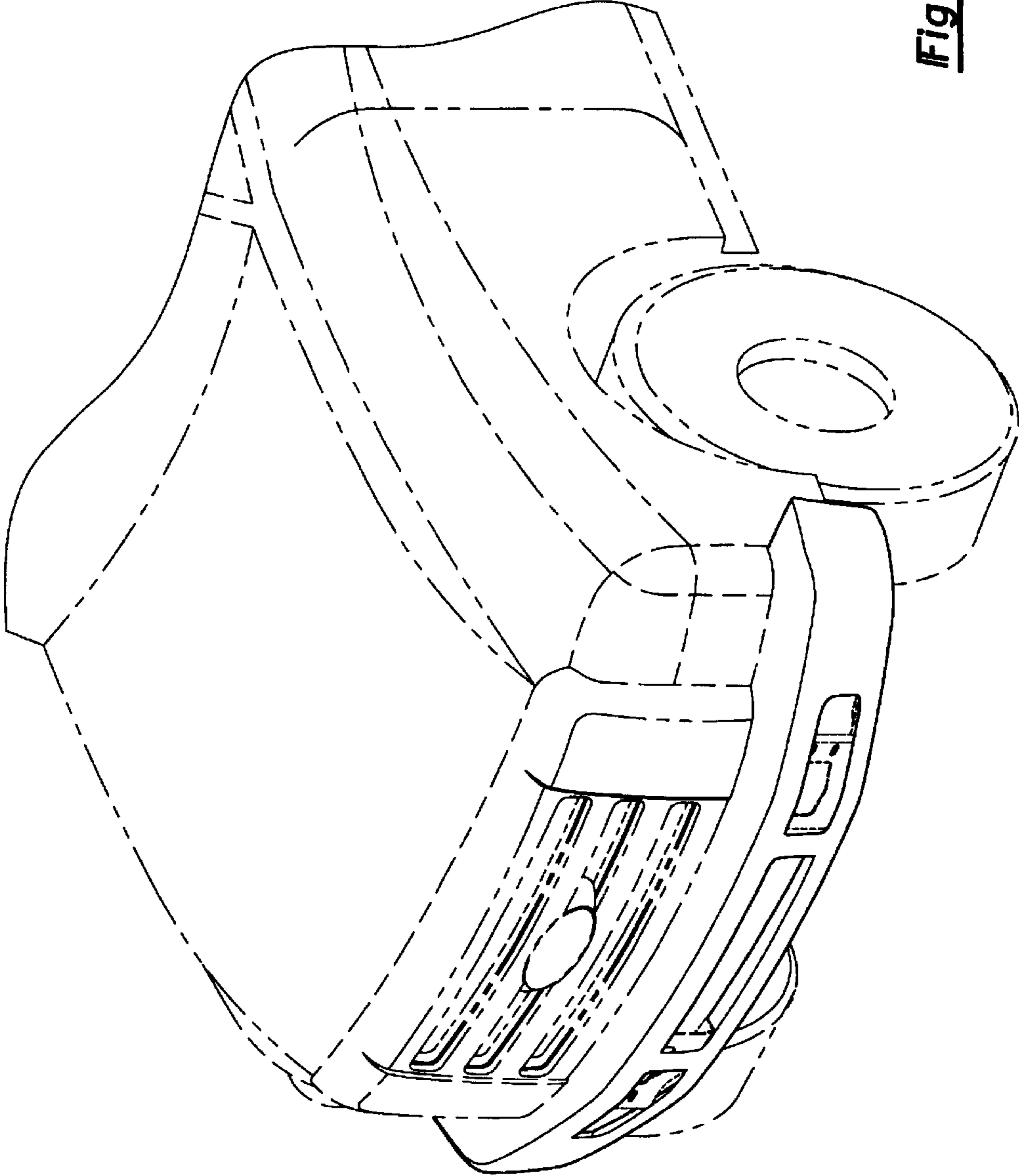

Fig-1

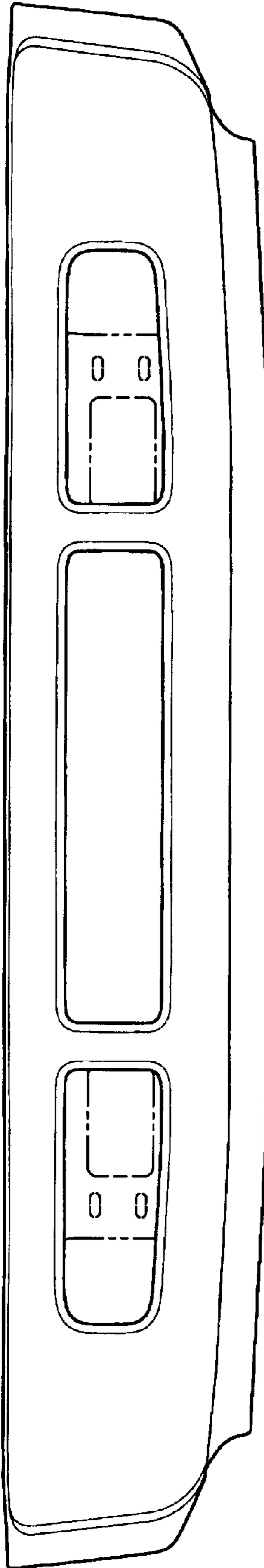

Fig-2

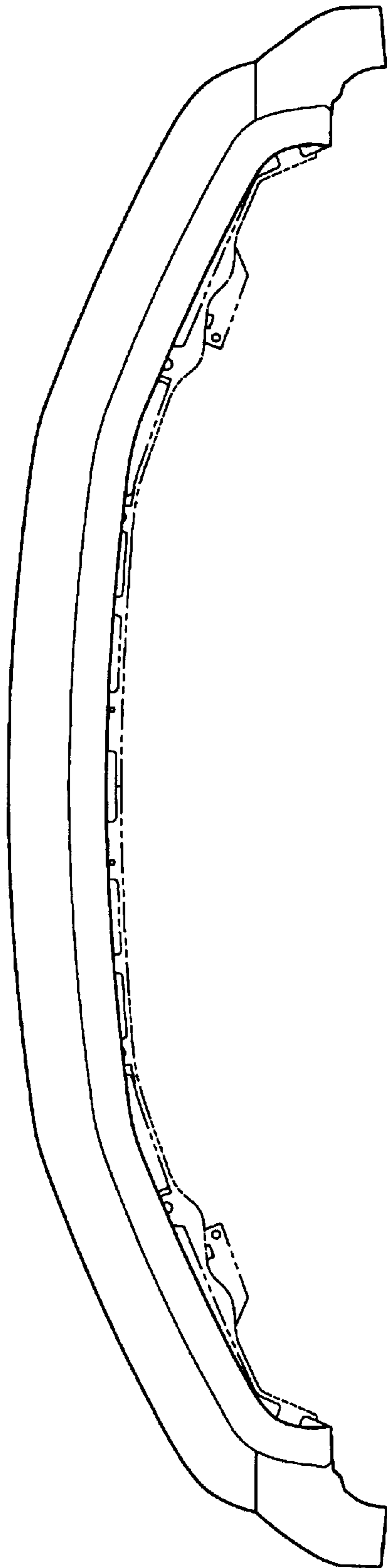

Fig-3

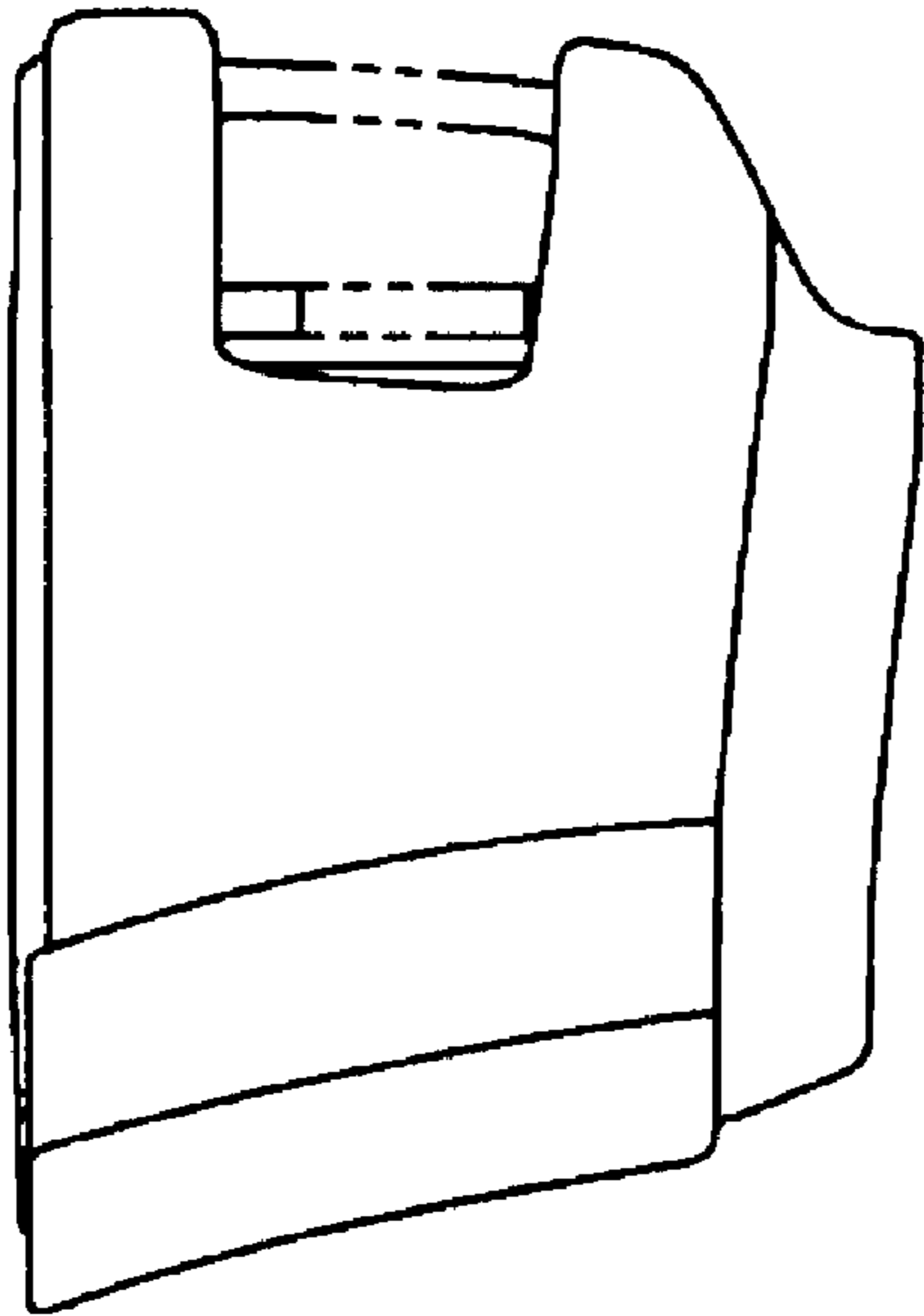

Fig-4

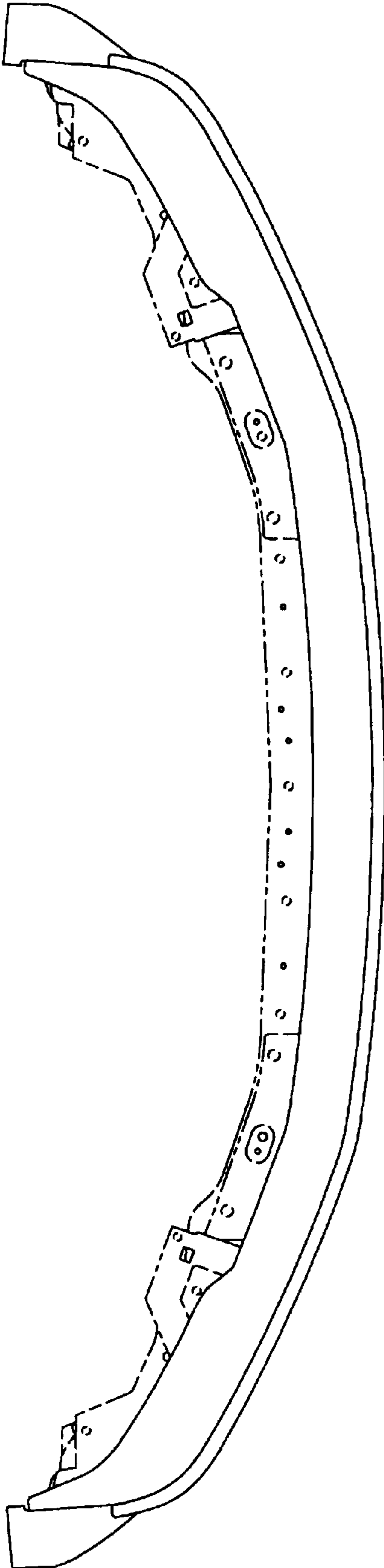

Fig-5