



US00D532411S

(12) **United States Design Patent**
Shimizu

(10) **Patent No.:** **US D532,411 S**

(45) **Date of Patent:** **** Nov. 21, 2006**

(54) **MICROPHONE**

(75) Inventor: **Minoru Shimizu**, Tokyo (JP)

(73) Assignee: **Sony Computer Entertainment Inc.**,
Tokyo (JP)

(**) Term: **14 Years**

(21) Appl. No.: **29/242,851**

(22) Filed: **Nov. 16, 2005**

(30) **Foreign Application Priority Data**

Jul. 15, 2005 (JP) D2005-020784

(51) **LOC (8) Cl.** **14-01**

(52) **U.S. Cl.** **D14/228**

(58) **Field of Classification Search** D14/225,
D14/226, 227, 228, 229, 142, 172, 155, 192,
D14/433; D10/104; D13/147; 181/158, 242;
379/430, 431, 432; 381/111, 122, 174, 355,
381/369

See application file for complete search history.

(56) **References Cited**

U.S. PATENT DOCUMENTS

2,910,539 A * 10/1959 Hartsfield 381/174
D200,051 S * 1/1965 Wassmann D14/228
D326,655 S * 6/1992 Iribe D14/192
D392,979 S * 3/1998 Inukai D14/228

D412,705 S * 8/1999 Laiacona et al. D14/172
D431,817 S 10/2000 Yuyama et al.
D442,932 S * 5/2001 Koike D14/155
D451,836 S * 12/2001 Fleetwood et al. D10/104

* cited by examiner

Primary Examiner—Paula A. Greene

(74) *Attorney, Agent, or Firm*—Rader, Fishman & Grauer
PLLC

(57) **CLAIM**

The ornamental design for a microphone, as shown and
described.

DESCRIPTION

FIG. 1 is a perspective view of a microphone showing my
new design;

FIG. 2 is a front elevational view thereof;

FIG. 3 is a rear elevational view thereof;

FIG. 4 is a left side elevational view thereof;

FIG. 5 is a right side elevational view thereof;

FIG. 6 is a top plan view thereof; and,

FIG. 7 is a bottom plan view thereof.

Portions of FIGS. 1–5, and 7 that are shown as broken lines
are for illustrative purpose only and form no part of the
claimed design. The dot-dash broken lines of FIGS. 1–5
define, but are not included in, the boundaries of the claimed
design.

1 Claim, 7 Drawing Sheets

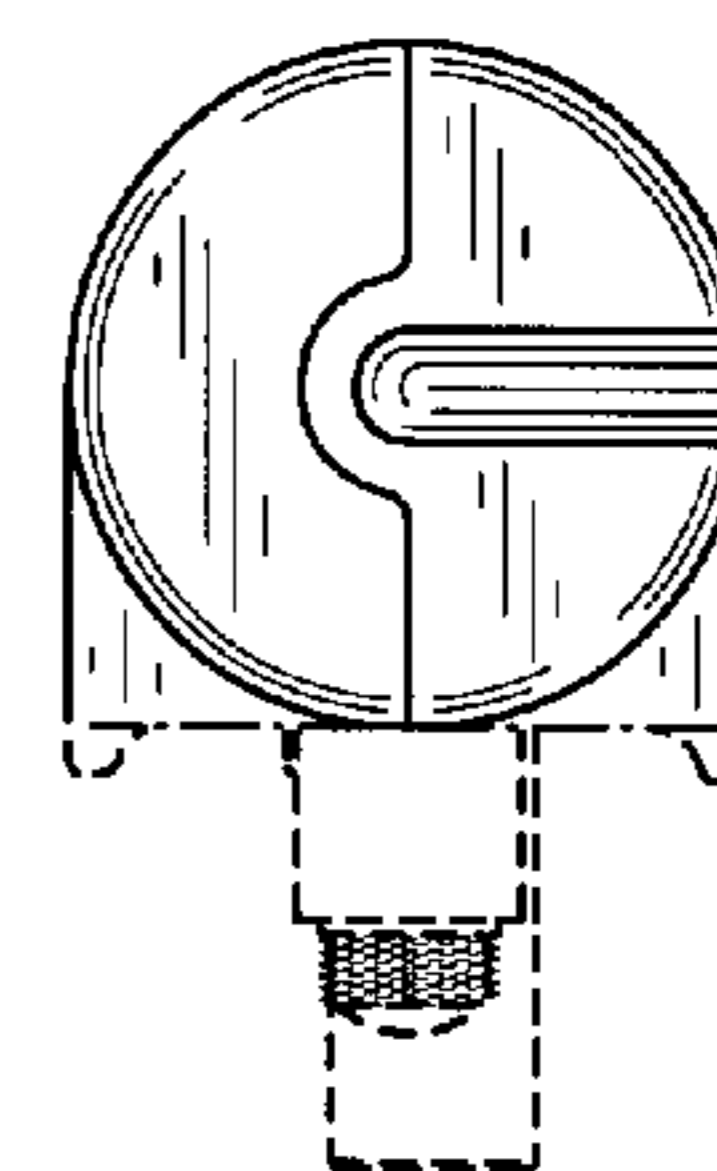
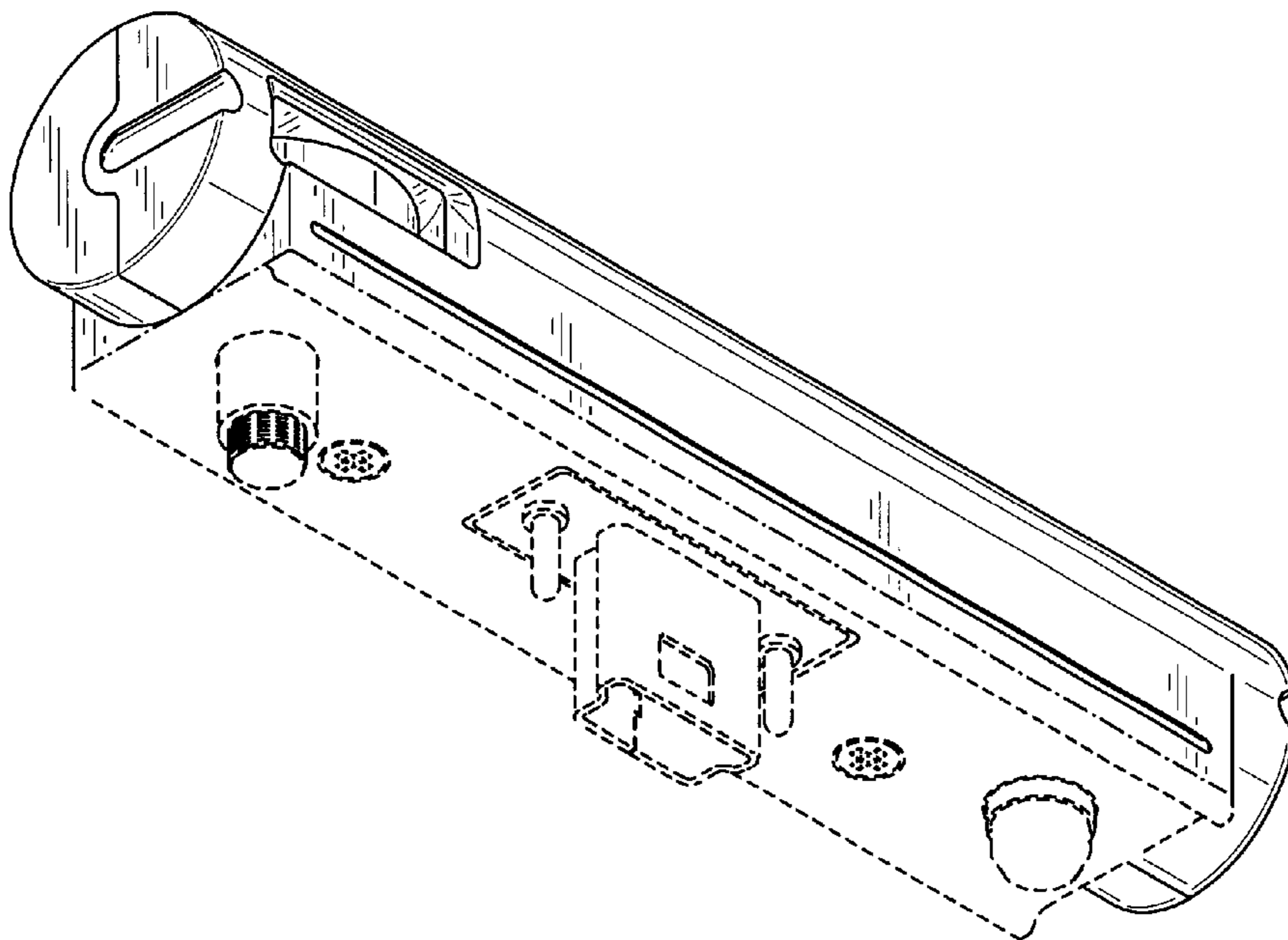

Fig. 1

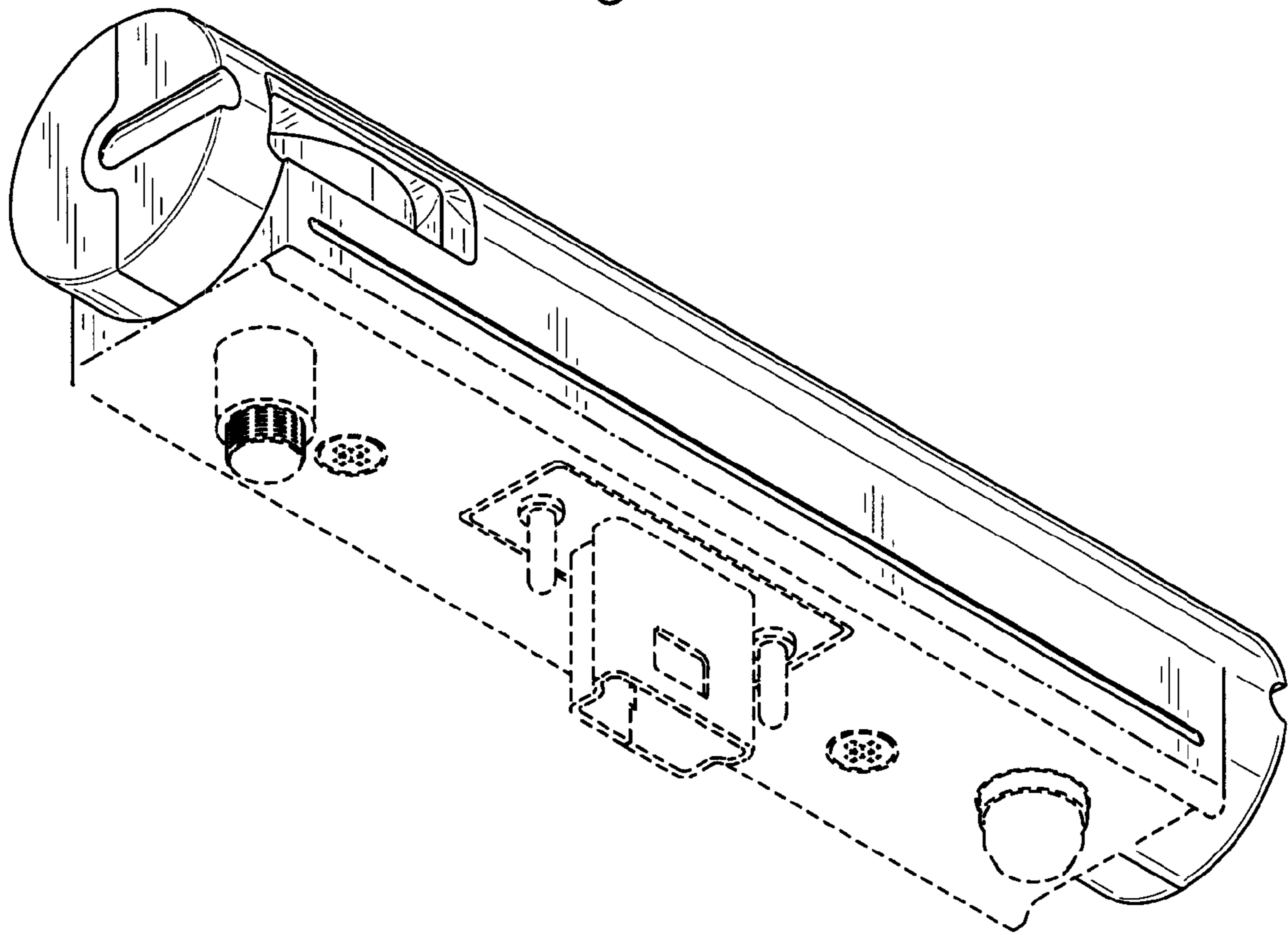

Fig.2

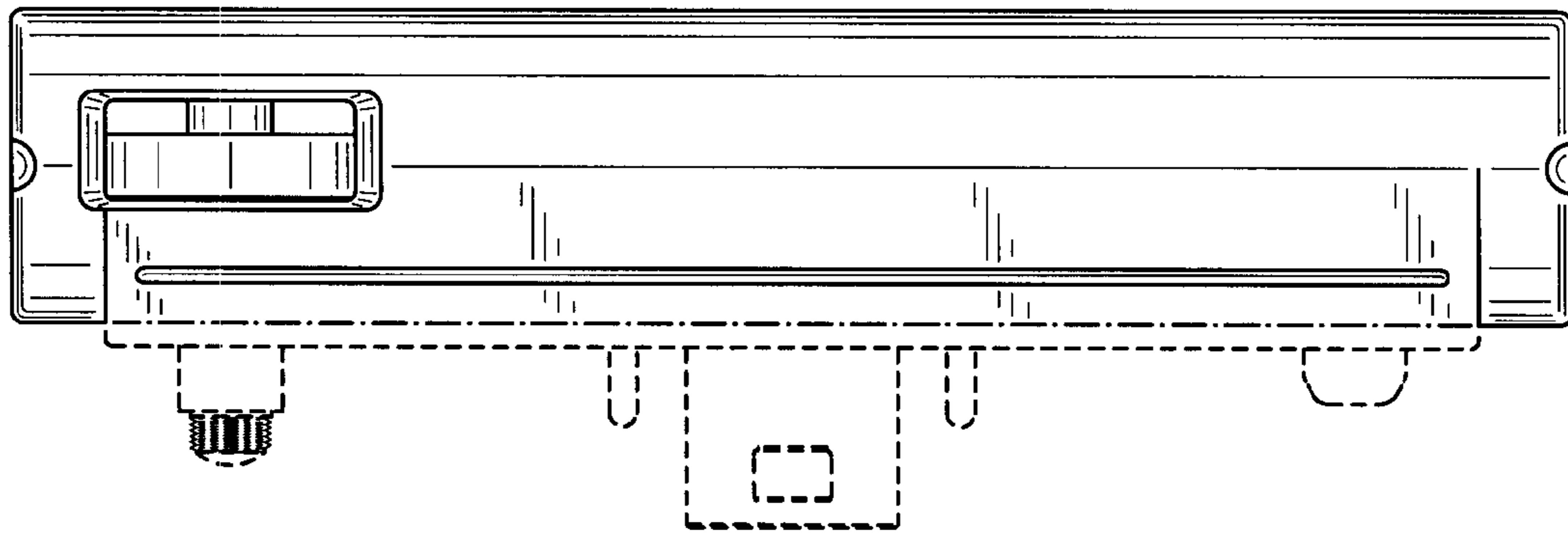

Fig.3

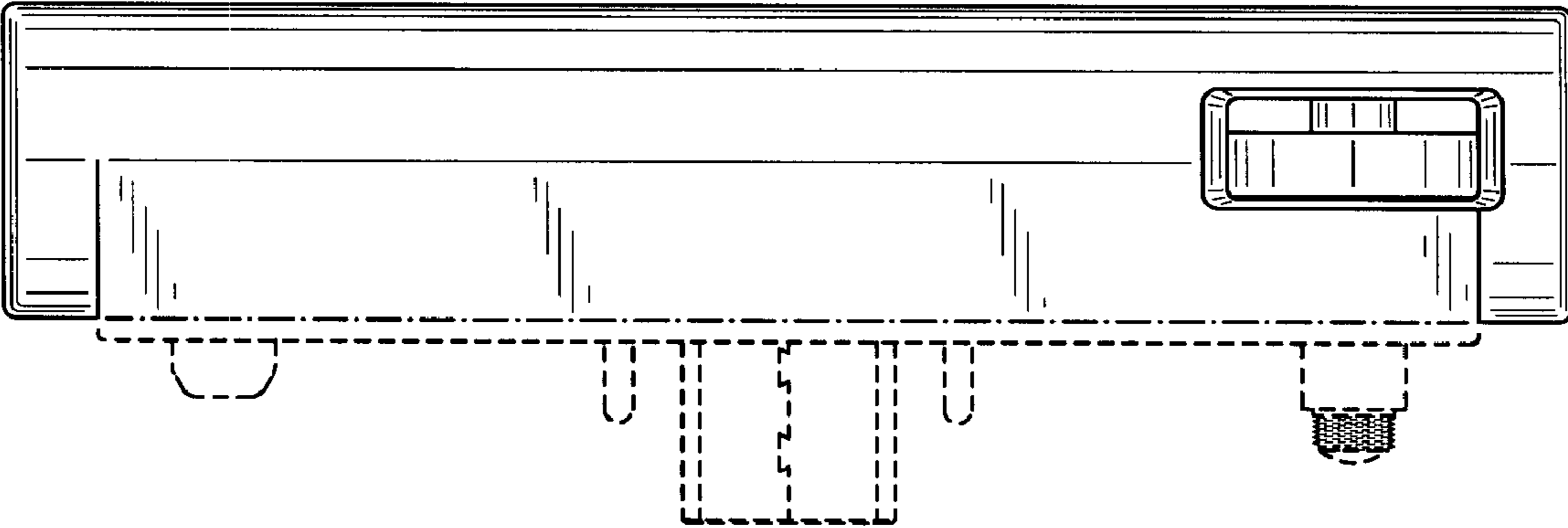

Fig.4

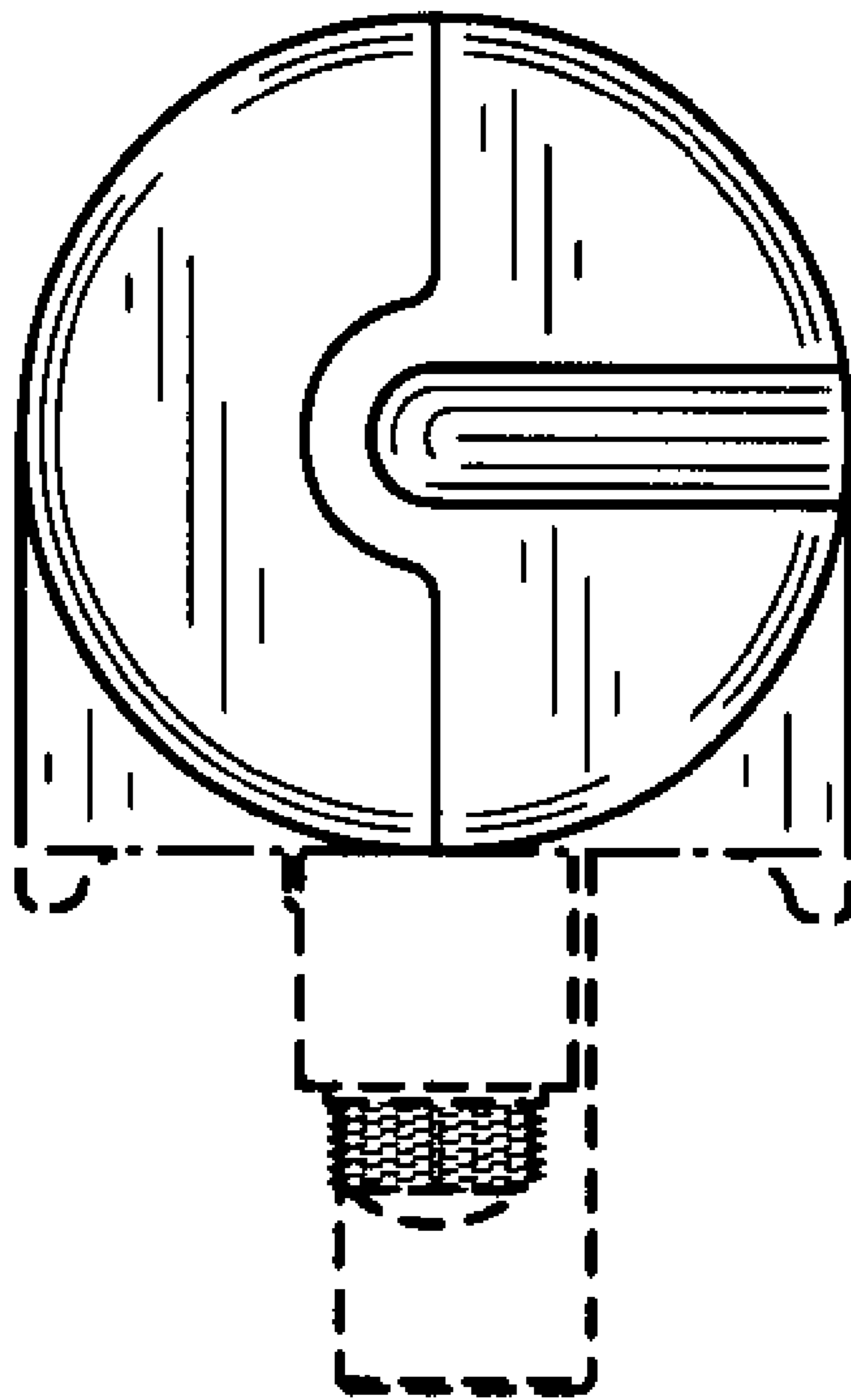

Fig.5

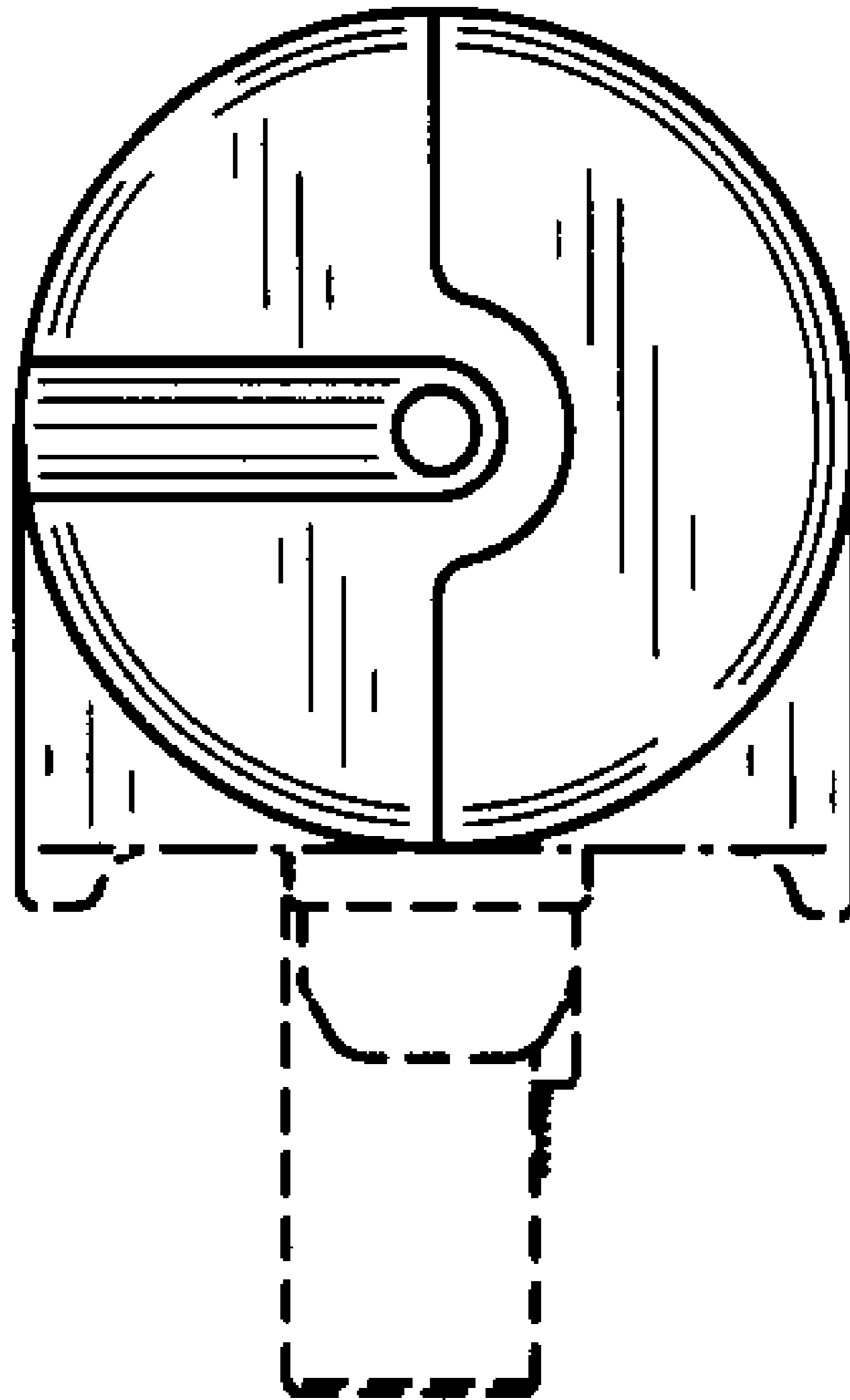

Fig.6

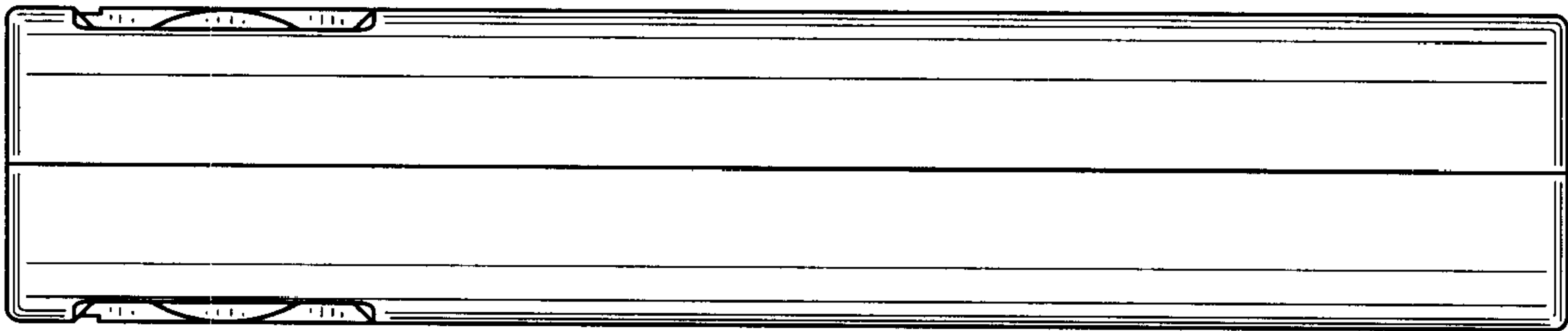

Fig.7

