



US00D532352S

(12) **United States Design Patent** (10) **Patent No.:** **US D532,352 S**
Angelo et al. (45) **Date of Patent:** **** Nov. 21, 2006**

(54) **FENDER PANELS FOR TRUCK HOOD**

Kenworth Truck Company T800 brochure, Kirkland, Wash, 2005.

(75) Inventors: **Gerald Jay Angelo**, Bellevue, WA (US); **Daniel Kieffer**, Kirkland, WA (US); **Wayne K. Simons**, Kent, WA (US); **Steven H. Hovind**, Bellevue, WA (US); **Daniel Farmer**, Coupeville, WA (US); **Richard D. Wailes, Jr.**, Woodinville, WA (US); **Erik David Hjorten**, Everett, WA (US)

(Continued)

Primary Examiner—Melody N. Brown
(74) *Attorney, Agent, or Firm*—Christensen O'Connor Johnson Kindness PLLC

(57) **CLAIM**

The ornamental design for fender panels for truck hood, as shown and described.

(73) Assignee: **PACCAR Inc**, Bellevue, WA (US)

DESCRIPTION

(**) Term: **14 Years**

FIG. 1 is a front perspective view of fender panels for truck hood showing a first embodiment of our new design;

(21) Appl. No.: **29/238,134**

FIG. 2 is a top plan view of the fender panels for truck hood of FIG. 1;

(22) Filed: **Sep. 12, 2005**

FIG. 3 is a bottom plan view of the fender panels for truck hood of FIG. 1;

(51) **LOC (8) Cl.** **12-16**

FIG. 4 is a front elevational view of the fender panels for truck hood of FIG. 1;

(52) **U.S. Cl.** **D12/184; D12/196**

FIG. 5 is a rear elevational view of the fender panels for truck hood of FIG. 1;

(58) **Field of Classification Search** D12/184,

D12/196, 90–92, 173, 96; 280/152.1, 847–849, 280/851; 296/185.1

FIG. 6 is a left side elevational view of the fender panels for truck hood of FIG. 1;

See application file for complete search history.

FIG. 7 is a right side elevational view of fender panels for truck hood of FIG. 1;

(56) **References Cited**

U.S. PATENT DOCUMENTS

D291,872 S 9/1987 Simons et al.
D291,982 S 9/1987 Simons et al.

(Continued)

OTHER PUBLICATIONS

Kenworth Truck Company W900 brochure, Kirkland, Wash, 2005.

FIG. 8 is a front perspective view of a fender panels for truck hood showing a second embodiment of our new design;

Kenworth Truck Company W900 brochure, Kirkland, Wash, 2002.

FIG. 9 is a top plan view of the fender panels for truck hood of FIG. 8;

Kenworth Truck Company W900 brochure, Kirkland, Wash, 1996.

FIG. 10 is a bottom plan view of the fender panels for truck hood of FIG. 8;

Kenworth Truck Company T2000 brochure, Kirkland, Wash, 2005.

FIG. 11 is a front elevational view of the fender panels for truck hood of FIG. 8;

Kenworth Truck Company T2000 brochure, Kirkland, Wash, 2002.

FIG. 12 is a rear elevational view of the fender panels for truck hood of FIG. 8;

FIG. 13 is a right side elevational view of the fender panels for truck hood of FIG. 8; and,

FIG. 14 is a left side elevational view of the fender panels for truck hood of FIG. 8.

The broken lines in the drawings form no part of the claimed design.

1 Claim, 8 Drawing Sheets

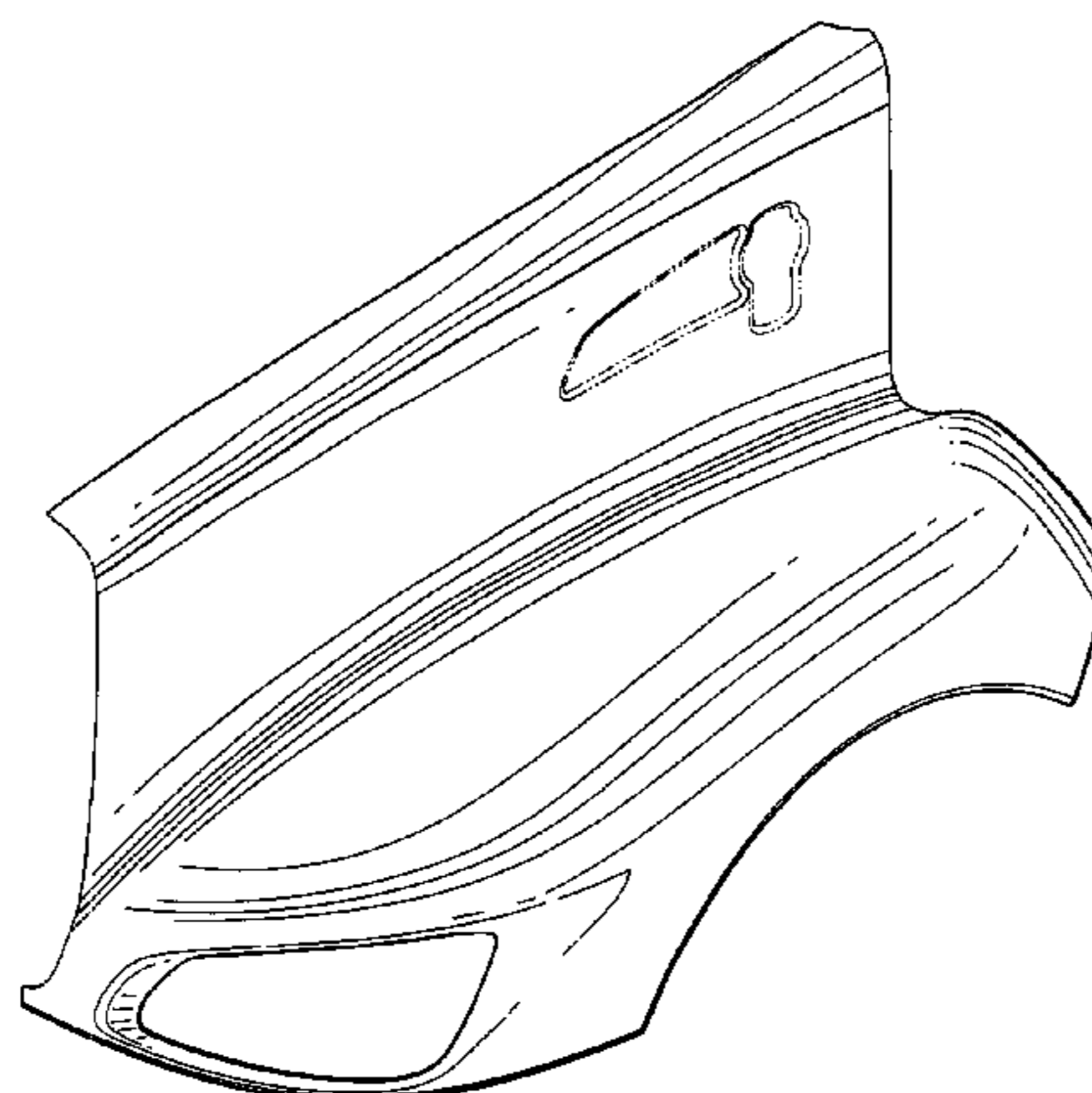

U.S. PATENT DOCUMENTS

D307,731 S 5/1990 Kerney et al.
 D308,032 S 5/1990 Kerney et al.
 D312,805 S 12/1990 Marlowe et al.
 D313,966 S 1/1991 Marlowe et al.
 D320,583 S 10/1991 Simons et al.
 D329,214 S 9/1992 Marlowe et al.
 D366,638 S 1/1996 Tucker et al.
 D366,640 S 1/1996 Tucker et al.
 D382,841 S 8/1997 Norwood et al.
 D382,844 S 8/1997 Norwood et al.
 D384,019 S 9/1997 Meryman et al.
 D395,860 S 7/1998 Meryman et al.
 D403,636 S 1/1999 Meryman et al.
 D411,140 S 6/1999 Meryman et al.
 D411,494 S 6/1999 Meryman et al.
 D422,251 S 4/2000 Bader et al.
 D423,990 S 5/2000 Meryman et al.
 D424,489 S 5/2000 Damon et al.
 D425,450 S 5/2000 Barraclough et al.
 D431,806 S 10/2000 Damon et al.
 D433,980 S 11/2000 Conway et al.
 D433,981 S 11/2000 Davis et al.
 D434,347 S 11/2000 Damon et al.
 D434,358 S 11/2000 Conway et al.
 D435,816 S 1/2001 Delashaw et al.
 D436,563 S 1/2001 Delashaw et al.
 D436,894 S 1/2001 Barraclough et al.
 D437,258 S 2/2001 Meryman et al.
 D437,570 S 2/2001 Meryman et al.

D446,175 S 8/2001 Hoyle, Jr.
 D475,657 S 6/2003 Wong et al.
 D478,300 S 8/2003 Chiang
 D482,993 S 12/2003 Conway et al.
 D484,077 S 12/2003 Conway et al.
 D497,581 S 10/2004 Conway et al.
 D502,904 S 3/2005 Delashaw et al.
 D504,642 S * 5/2005 Perfetti et al. D12/173
 D511,727 S * 11/2005 Shaw et al. D12/184
 D514,483 S 2/2006 Chiang
 D518,761 S 4/2006 Chiang

OTHER PUBLICATIONS

Kenworth Truck Company T800 brochure, Kirkland, Wash, 2003.
 Kenworth Truck Company T800 brochure, Kirkland, Wash, 2002.
 Kenworth Truck Company T600 brochure, Kirkland, Wash, 2005.
 Kenworth Truck Company T600 brochure, Kirkland, Wash, 2002.
 Kenworth Truck Company T600 brochure, Kirkland, Wash, 1996.
 Kenworth Truck Company T300 brochure, Kirkland, Wash, 2005.
 Kenworth Truck Company T300 brochure, Kirkland, Wash, 2001.

* cited by examiner

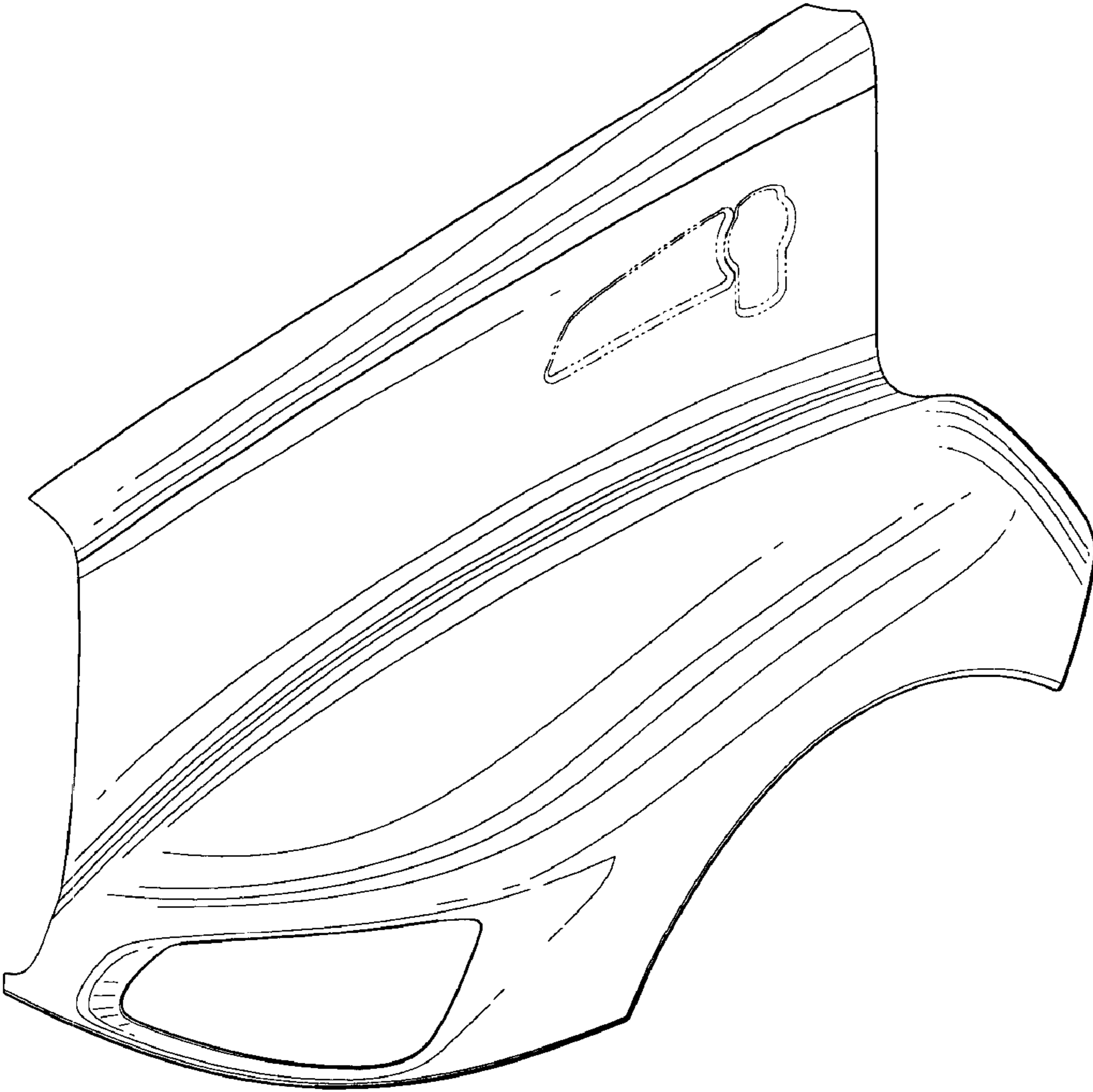

Fig.1.



Fig. 2.

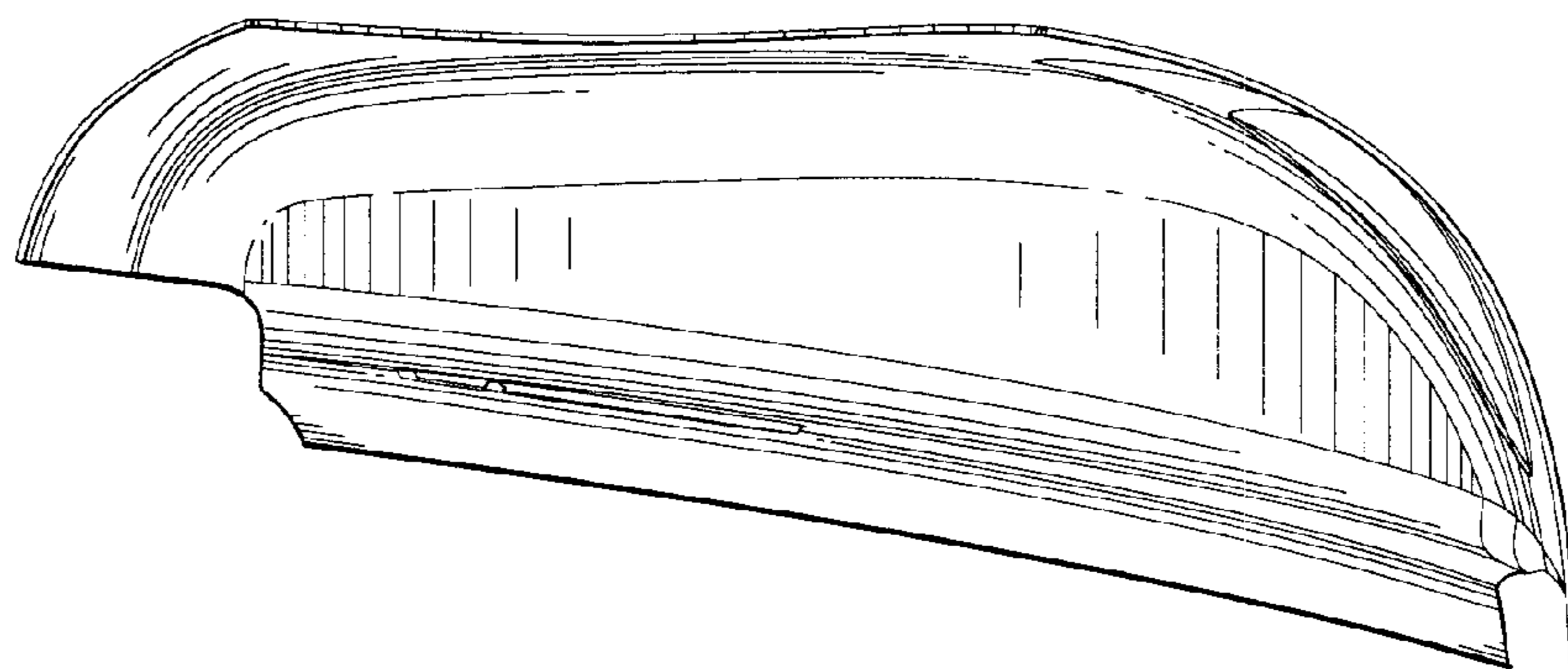

Fig. 3.

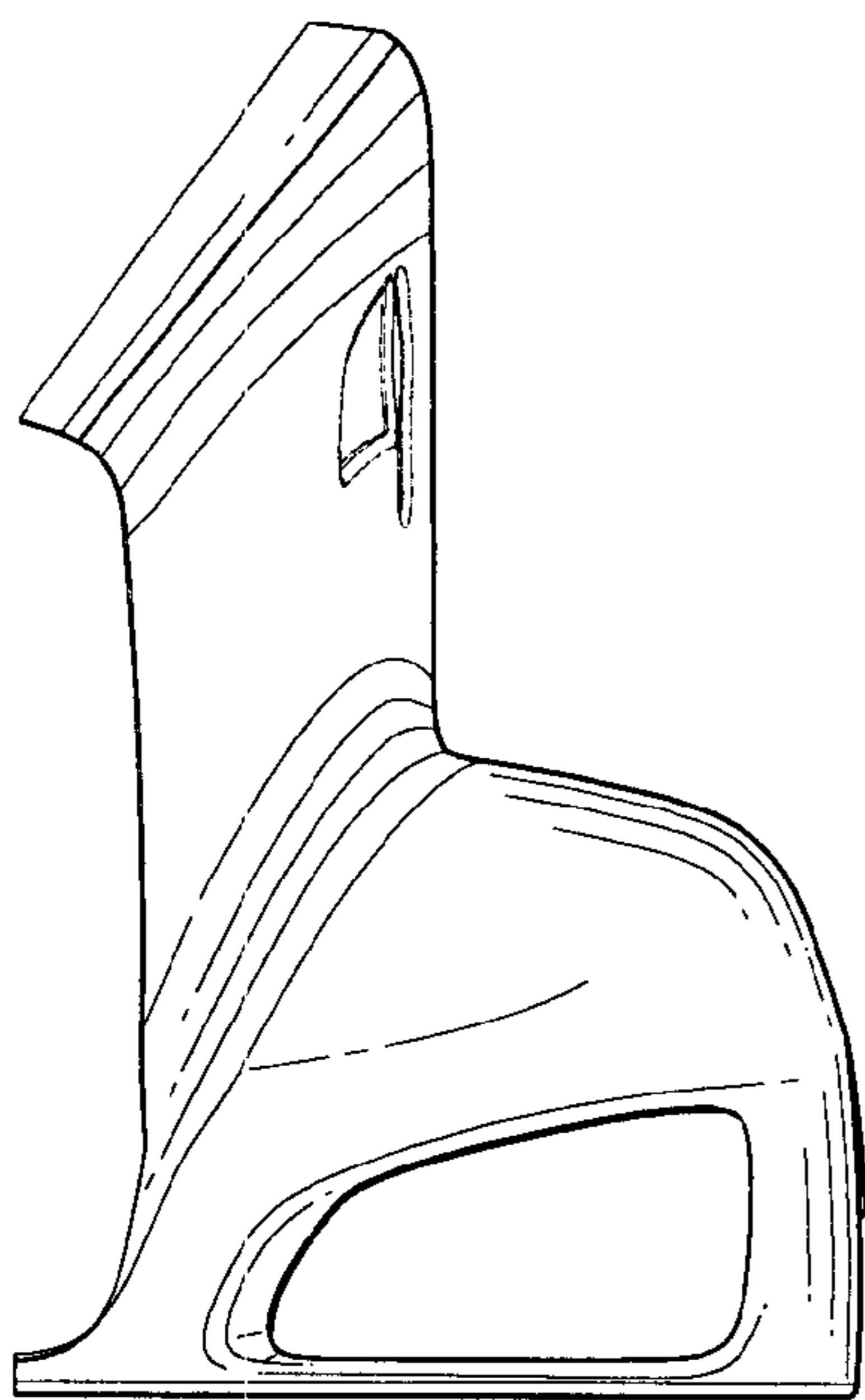

Fig.4.

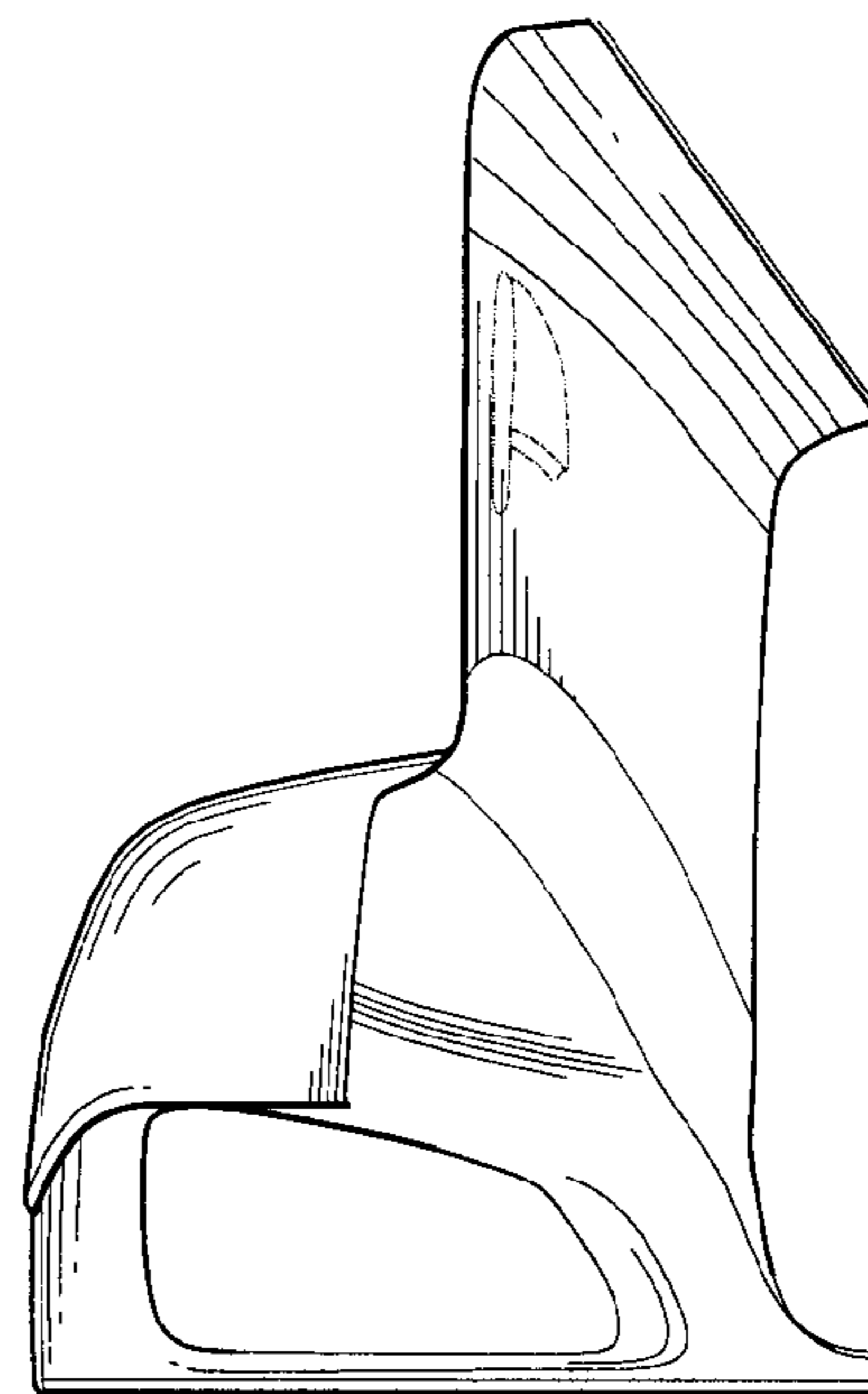

Fig.5.

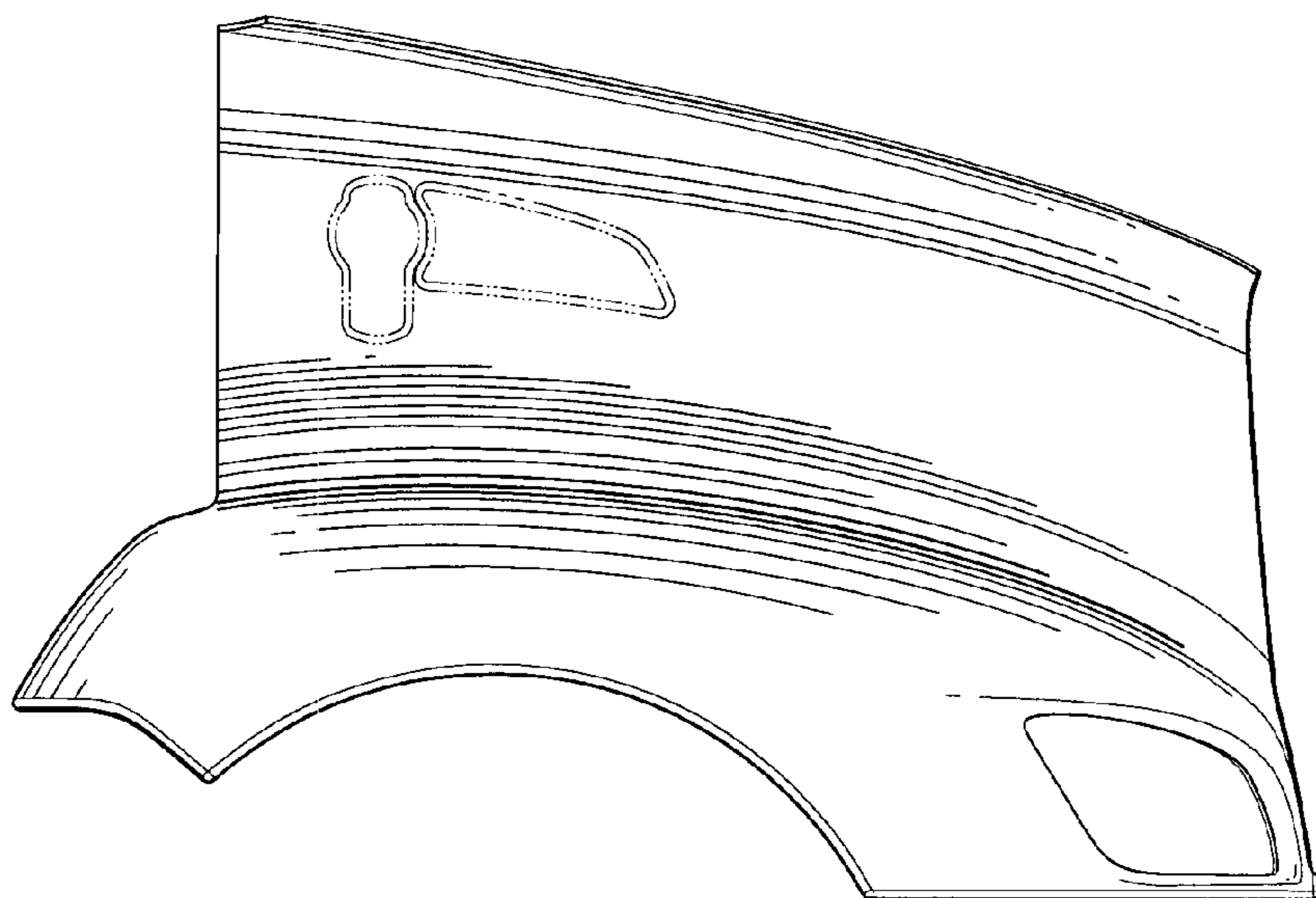

Fig. 6.

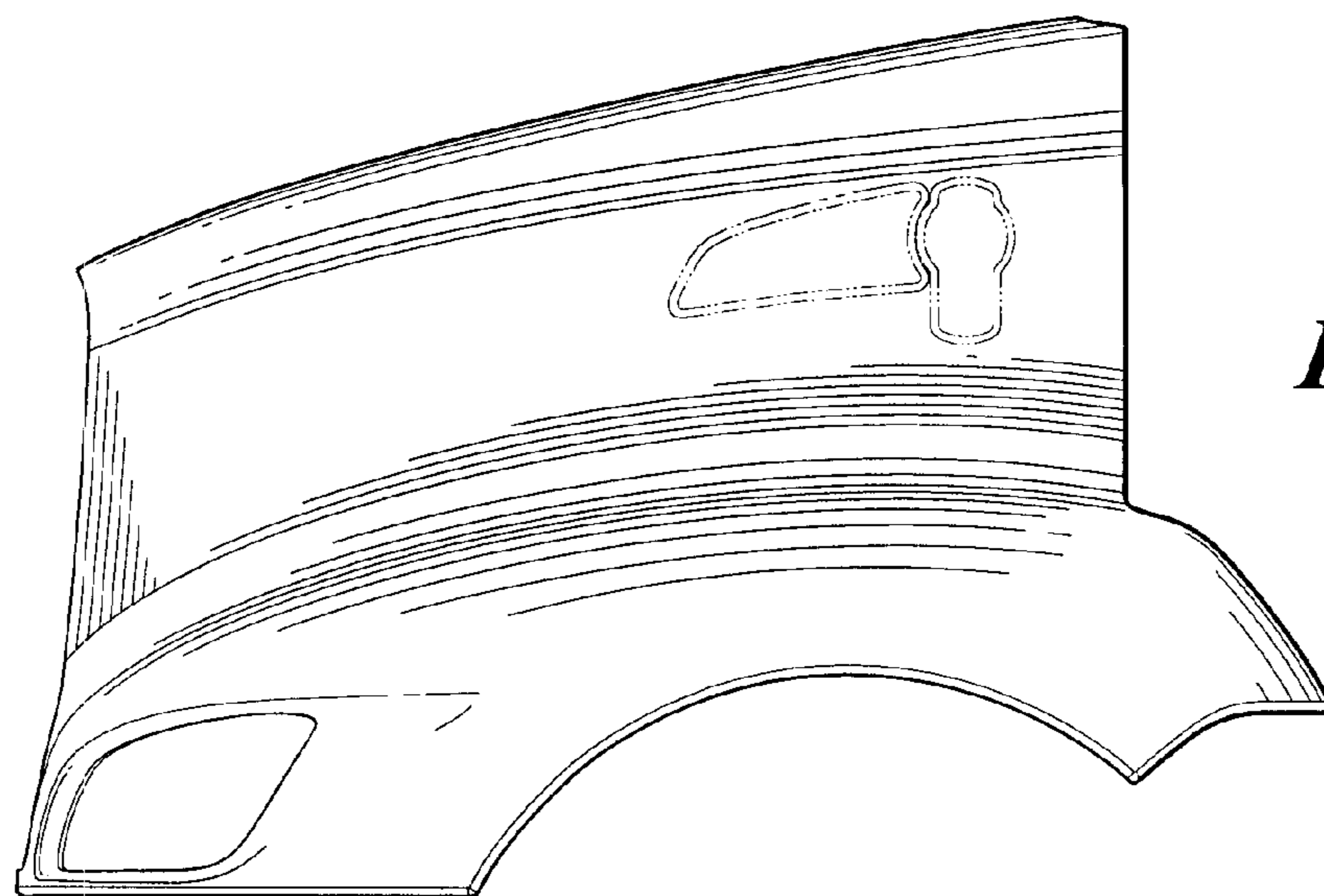

Fig. 7.

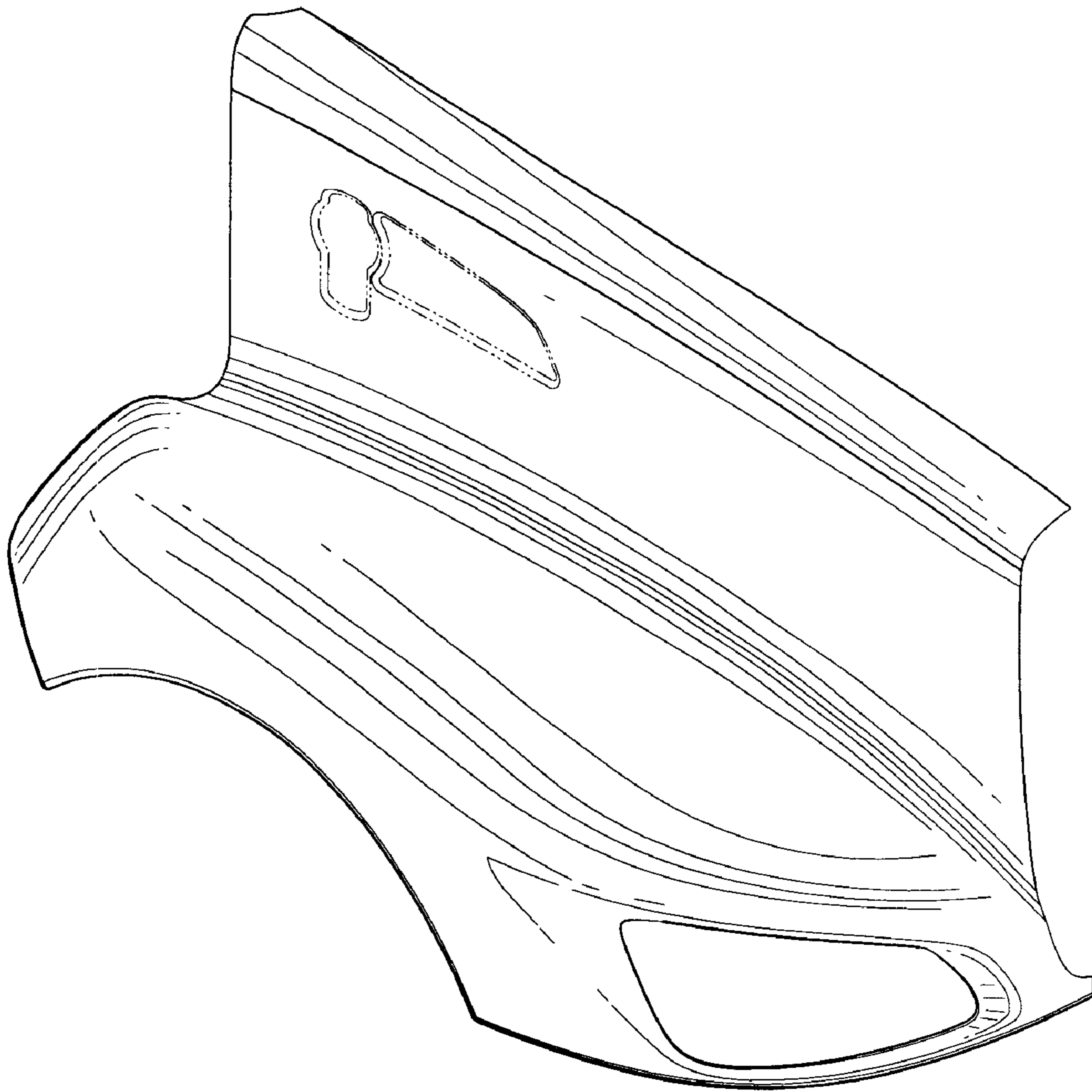

Fig. 8.



Fig. 9.

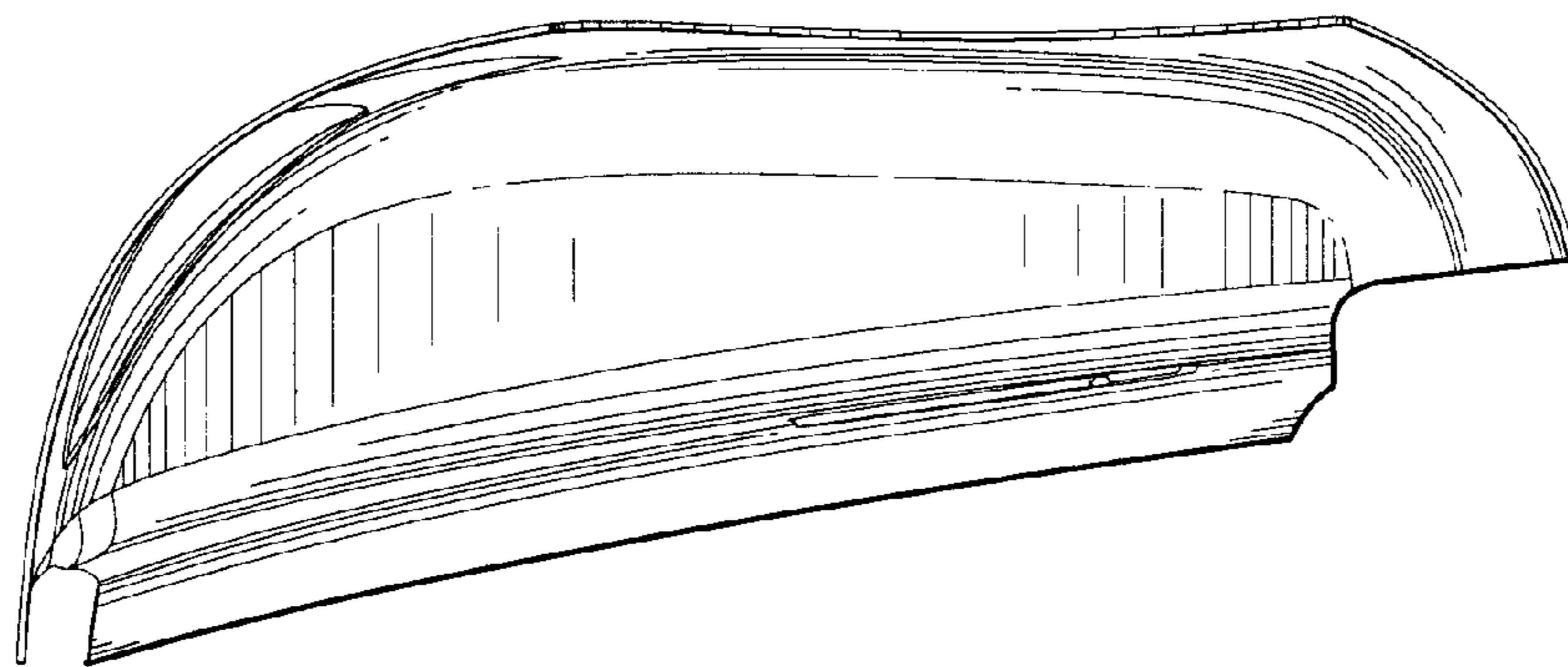

Fig. 10.

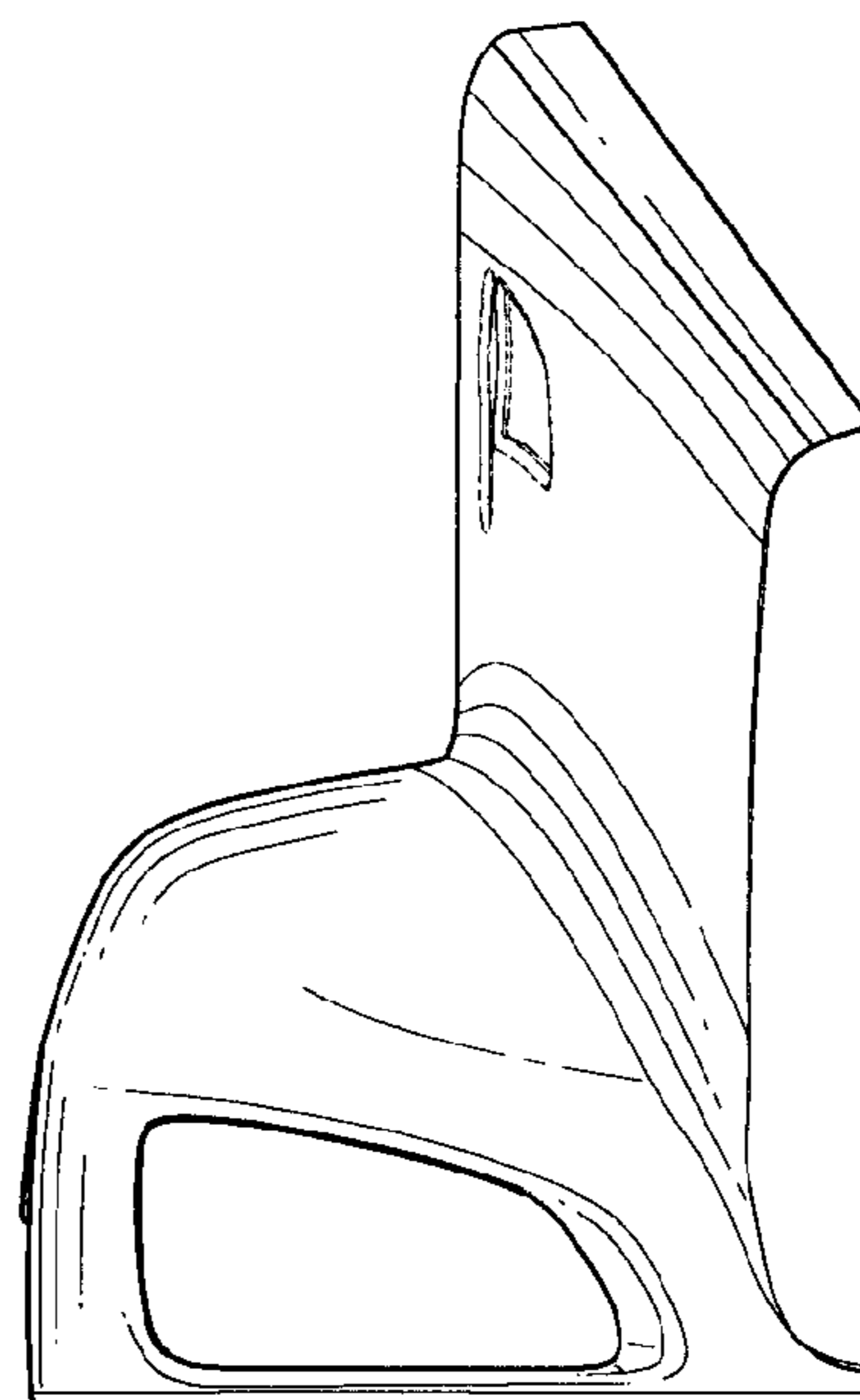

Fig. 11.

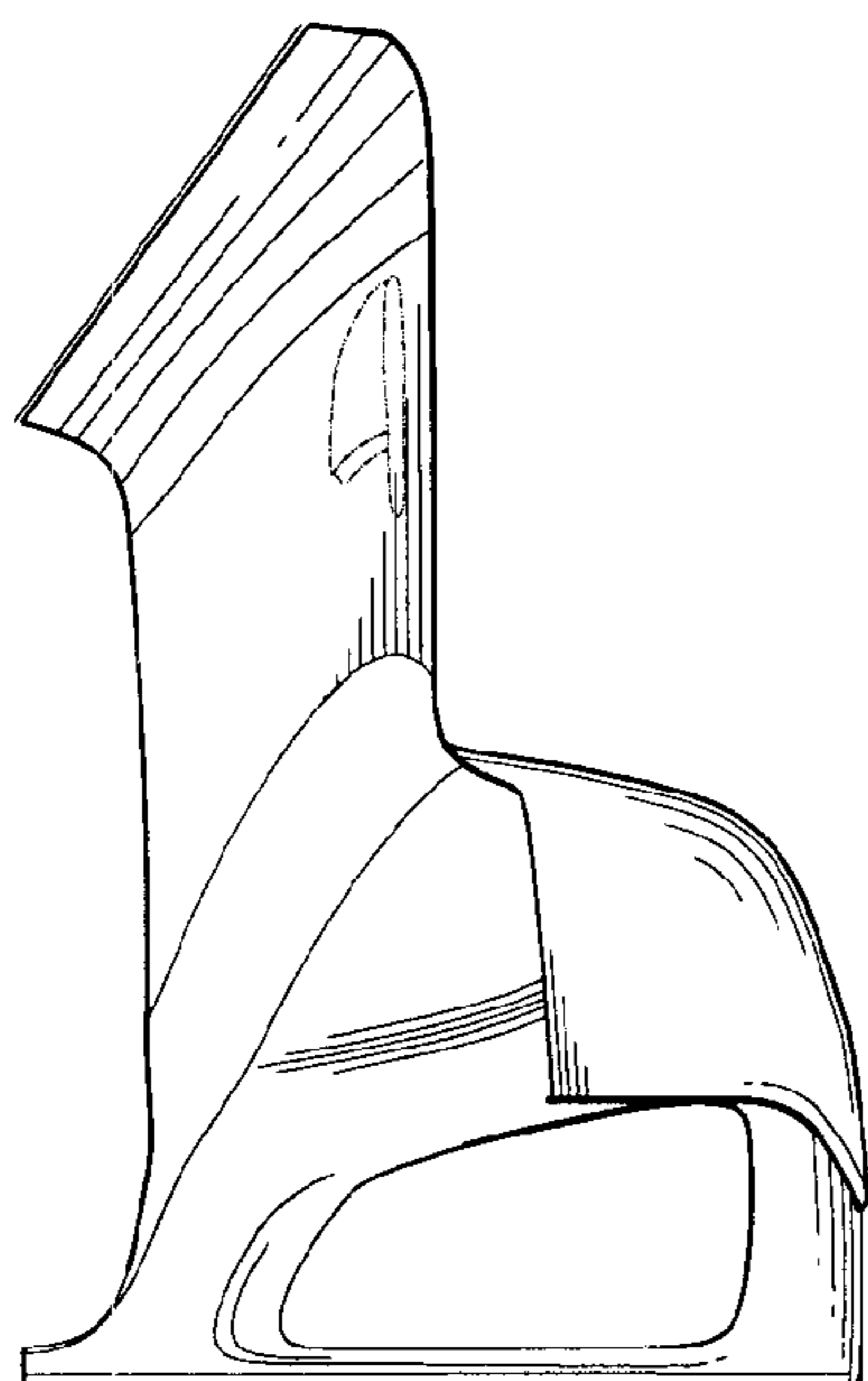

Fig. 12.

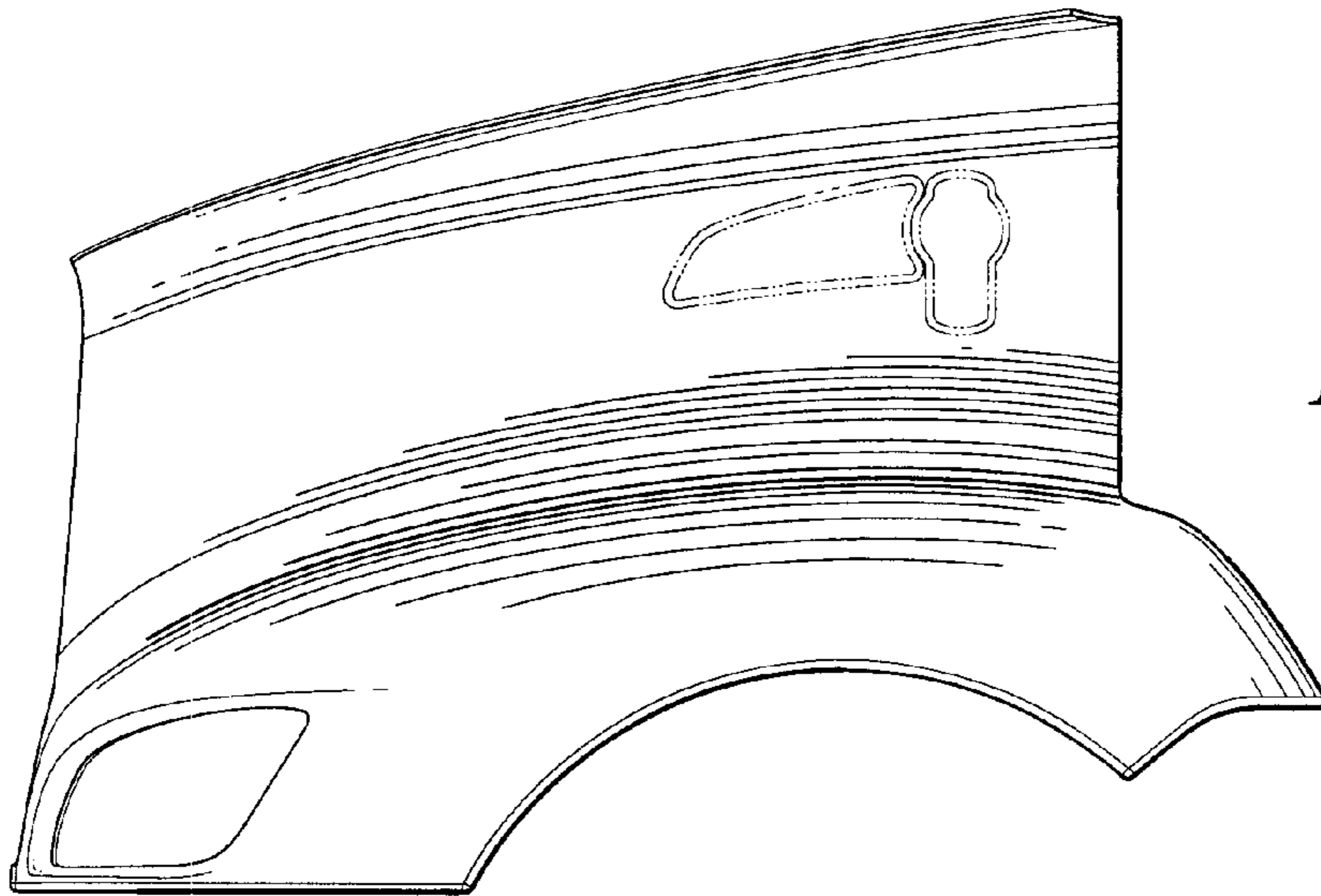

Fig. 13.

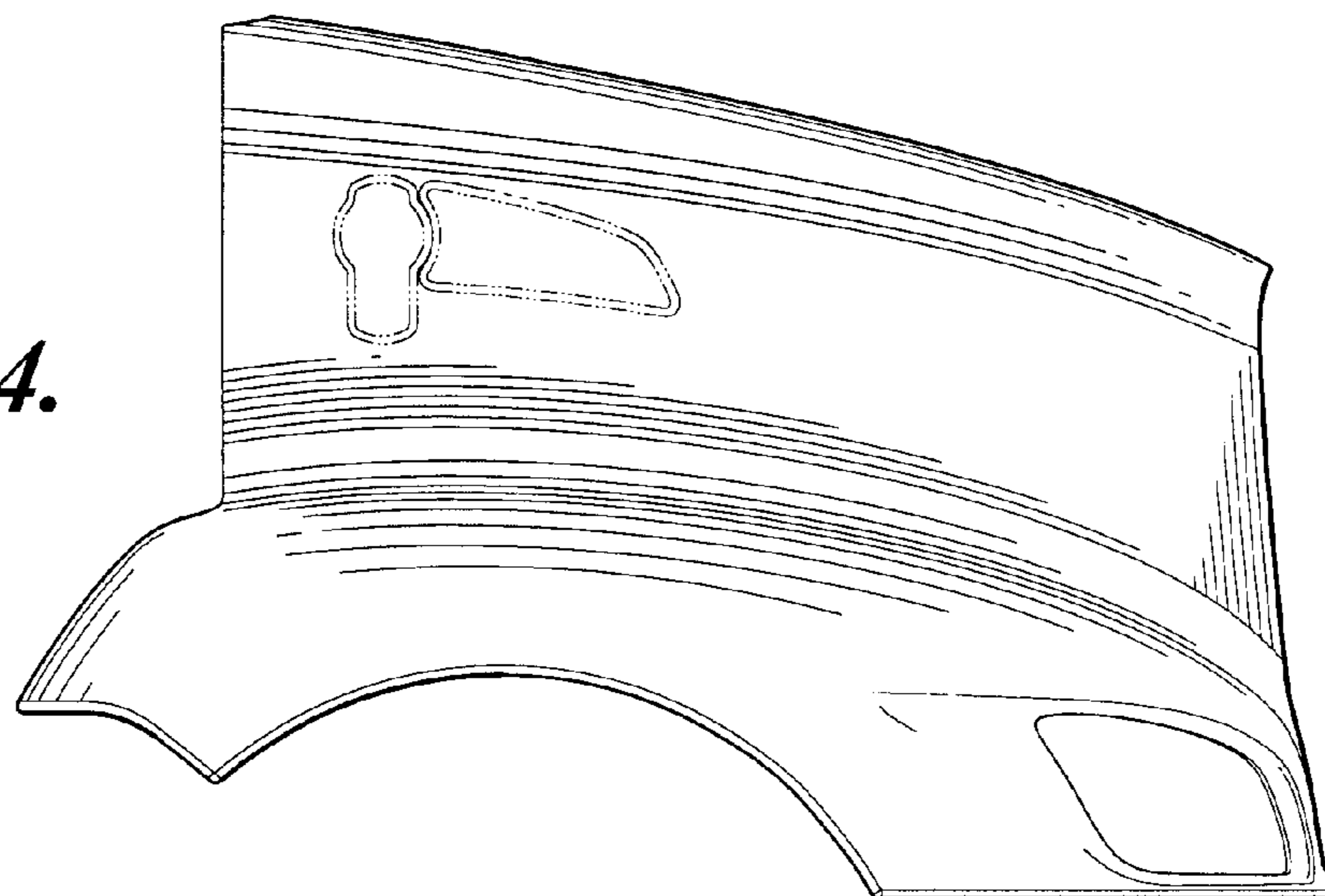

Fig. 14.