



US00D532082S

(12) **United States Design Patent**
Cimbura

(10) **Patent No.:** **US D532,082 S**

(45) **Date of Patent:** **** Nov. 14, 2006**

(54) **FUEL INJECTION AIR VALVE**

5,501,192 A * 3/1996 Cutler 123/336

(75) Inventor: **David J. Cimbura**, Denver, CO (US)

* cited by examiner

(73) Assignee: **Momar Injection, Inc.**, Denver, CO (US)

Primary Examiner—Ian Simmons

Assistant Examiner—Maurice Stevens

(**) Term: **14 Years**

(74) *Attorney, Agent, or Firm*—Edwin H. Crabtree; Ramon L. Pizarro

(21) Appl. No.: **29/239,635**

(57) **CLAIM**

(22) Filed: **Sep. 30, 2005**

The ornamental design for a fuel injection air valve, as shown and described.

(51) **LOC (8) Cl.** **23-01**

(52) **U.S. Cl.** **D23/233; D15/5**

(58) **Field of Classification Search** D23/233;
D15/5; 123/587–588, 452, 533, 179.16, 495,
123/432, 366–367, 472, 403, 590, 593, 184.21,
123/184.32, 184.36

See application file for complete search history.

DESCRIPTION

FIG. 1 is a perspective view of the fuel injection air valve illustrating my new design.

FIG. 2 is a top view thereof;

FIG. 3 is a front view thereof;

FIG. 4 is a side view thereof;

FIG. 5 is a bottom view thereof;

FIG. 6 is an opposite side view thereof; and,

FIG. 7 is a rear view thereof.

The broken lines shown in FIG. 2 are for illustrative purposes only and forms no part of the claimed design.

(56) **References Cited**

U.S. PATENT DOCUMENTS

1,499,794 A * 7/1924 Wennerby 123/533

4,064,854 A * 12/1977 Fehrenbach et al. 123/452

4,197,823 A * 4/1980 Schwartz et al. 123/587

1 Claim, 2 Drawing Sheets

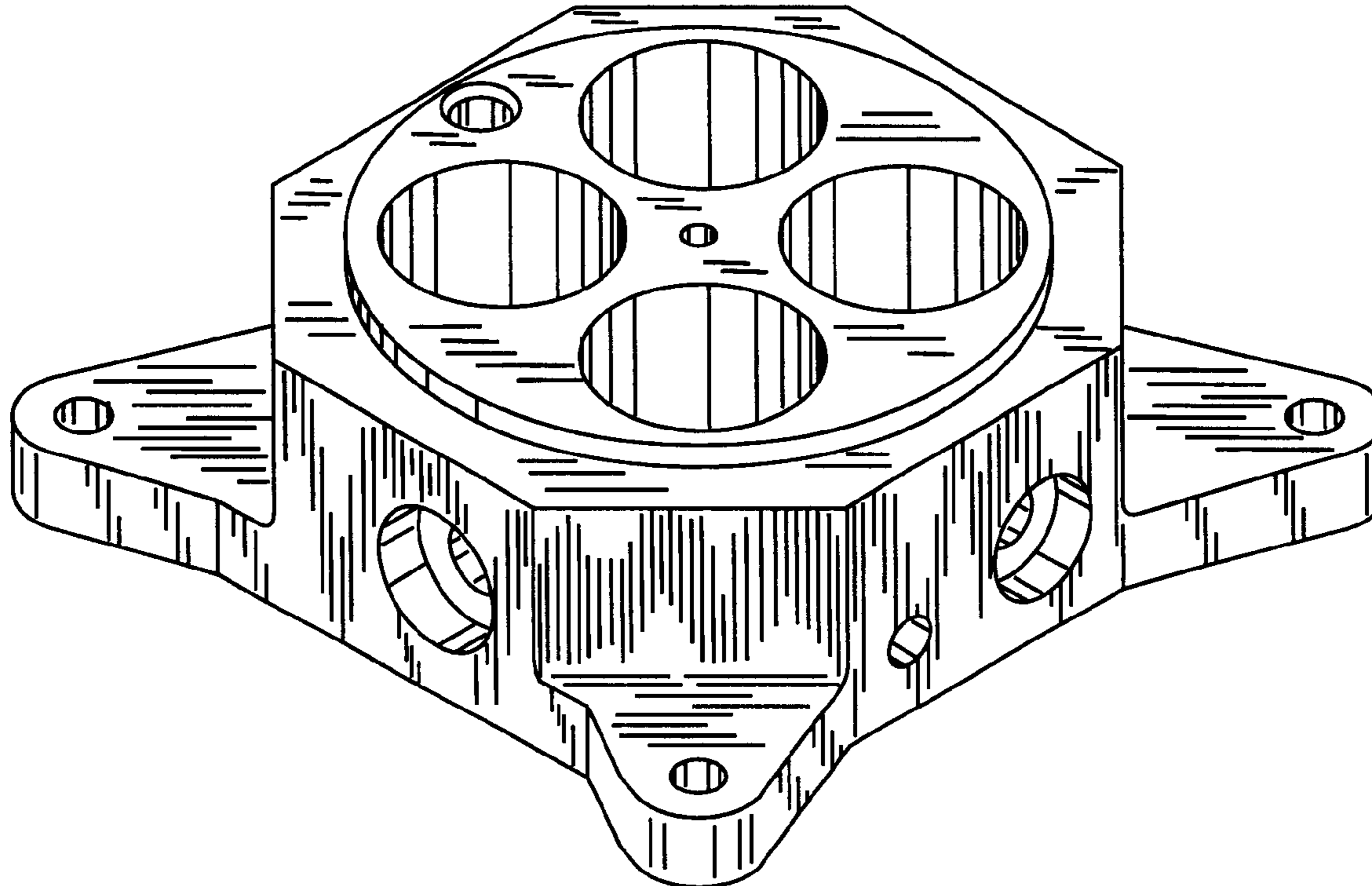

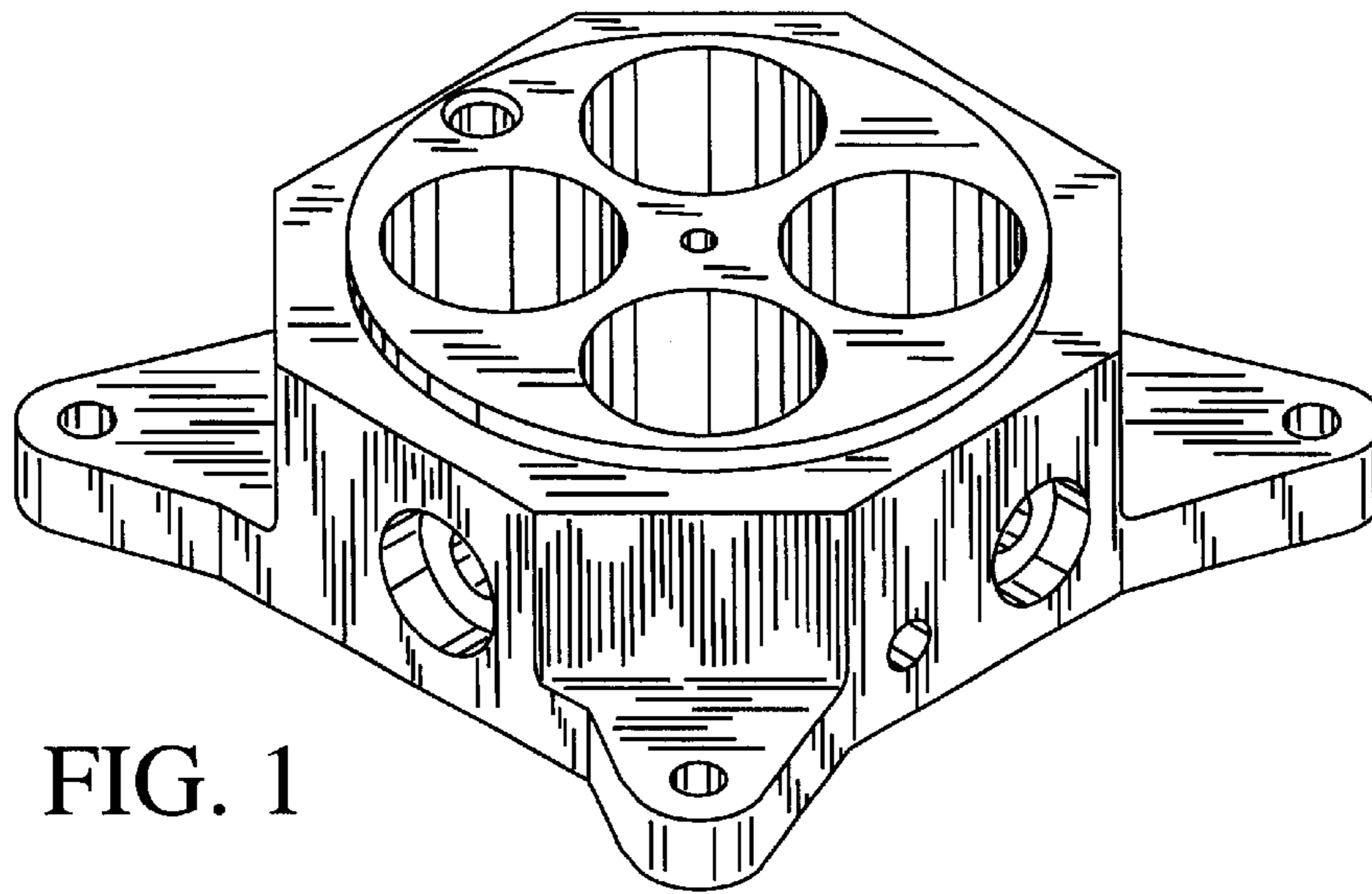

FIG. 1

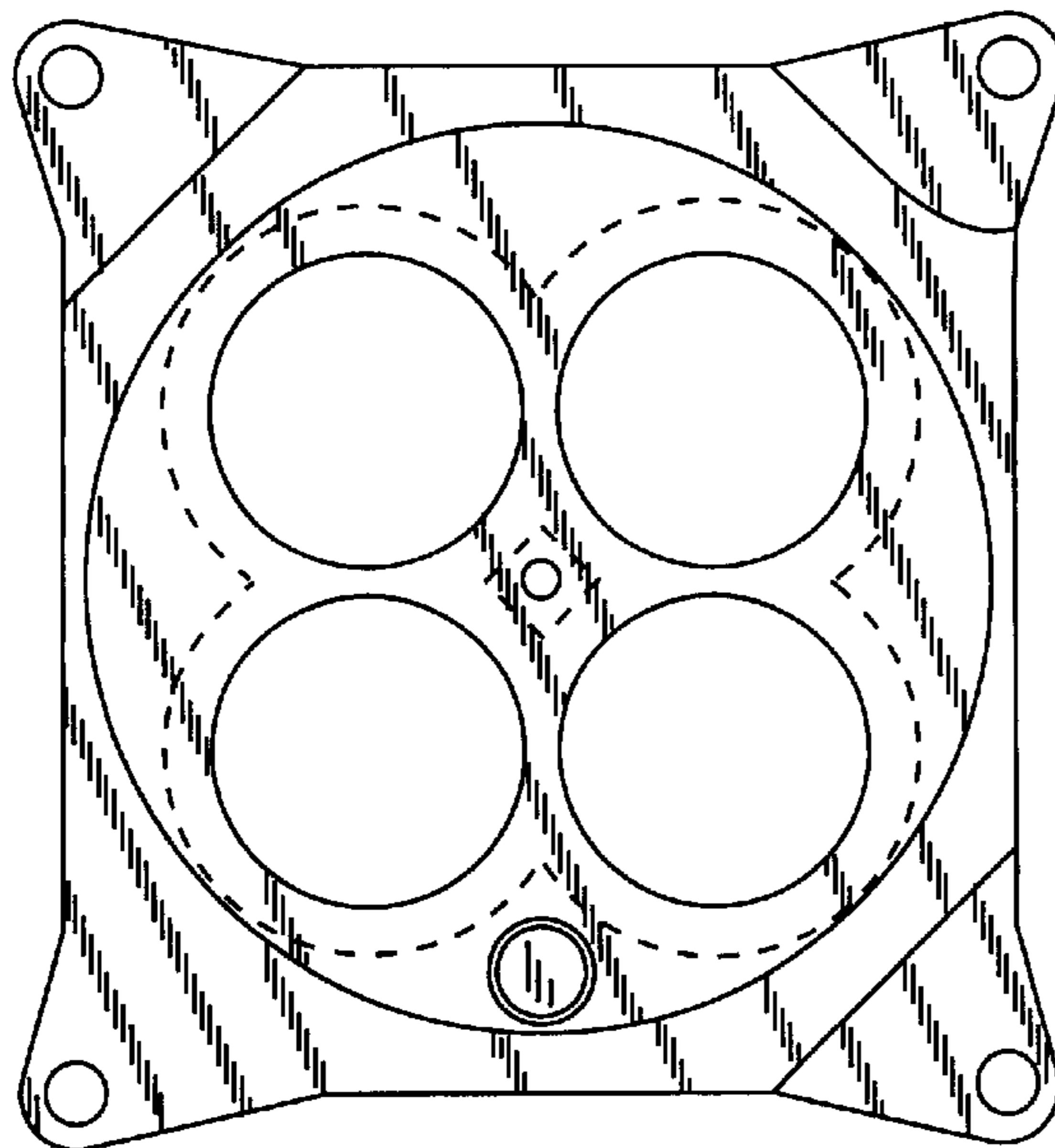

FIG. 2

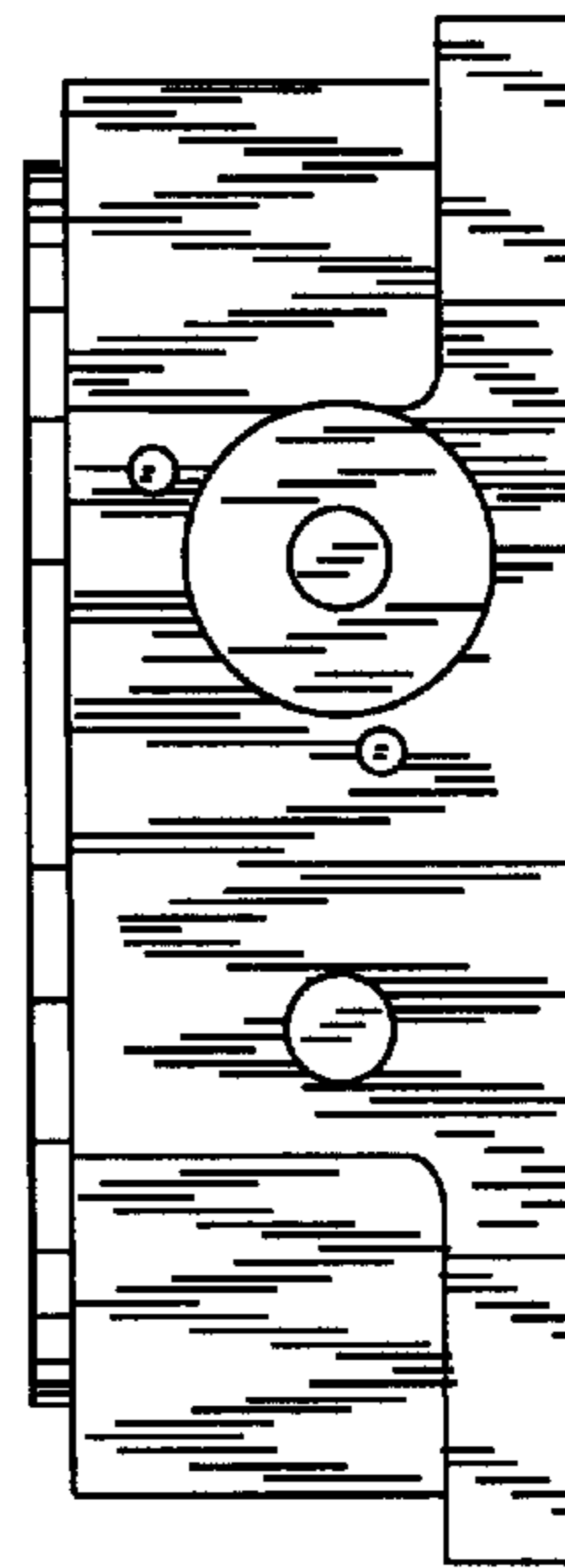

FIG. 3

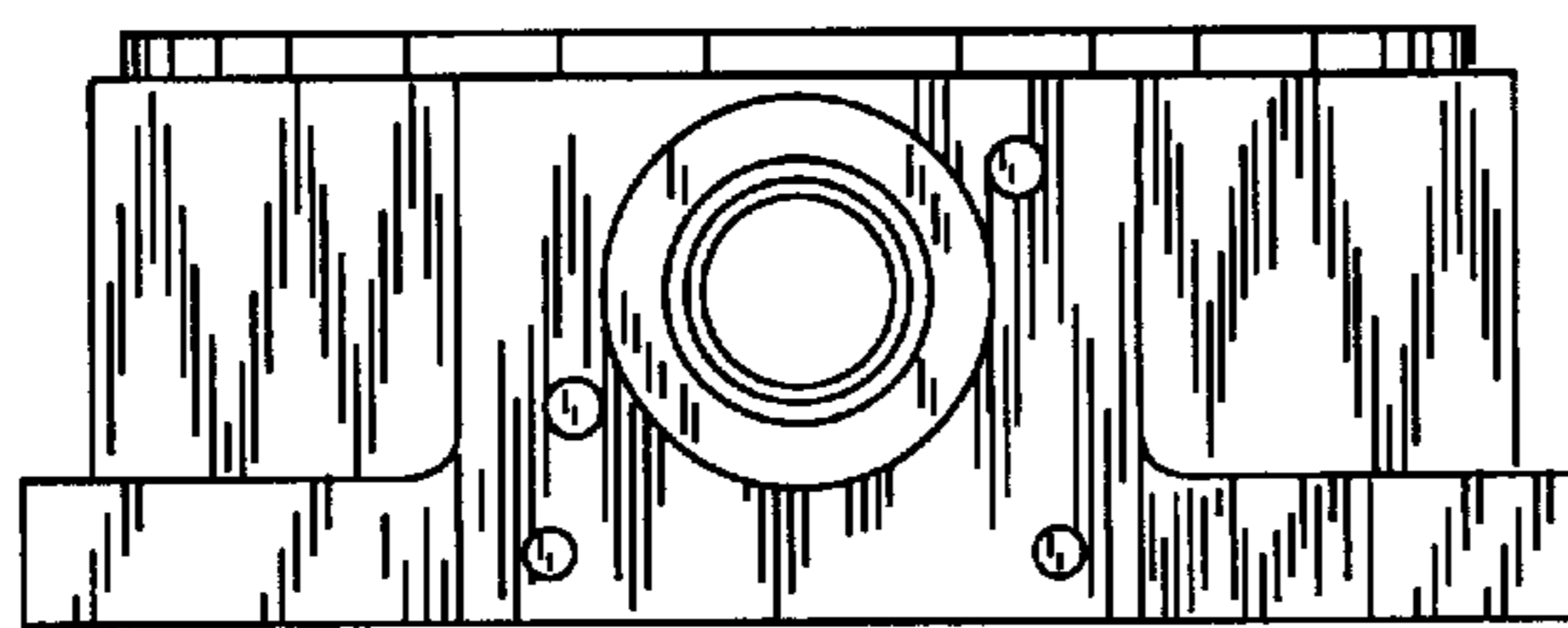

FIG. 4

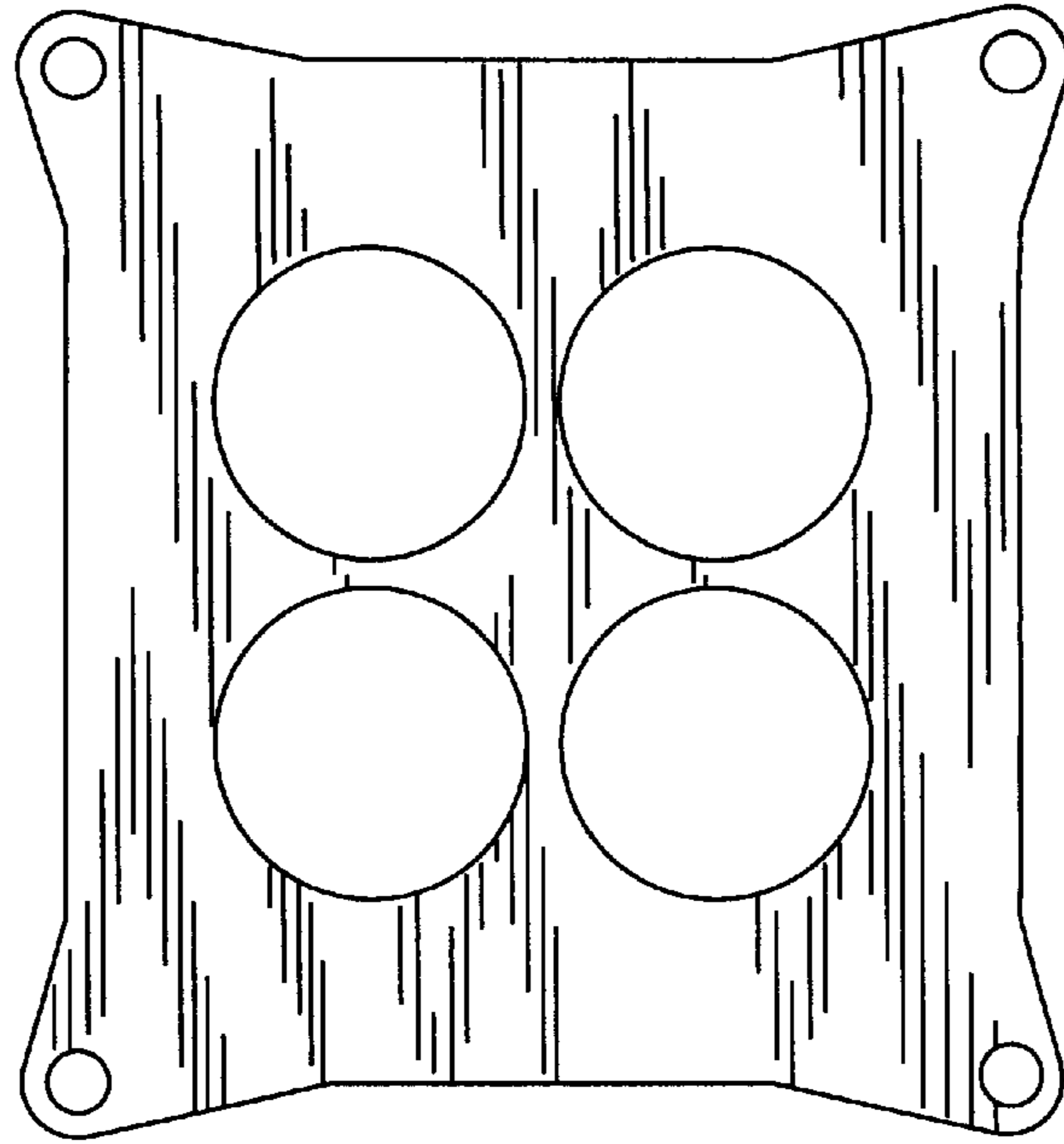

FIG. 5

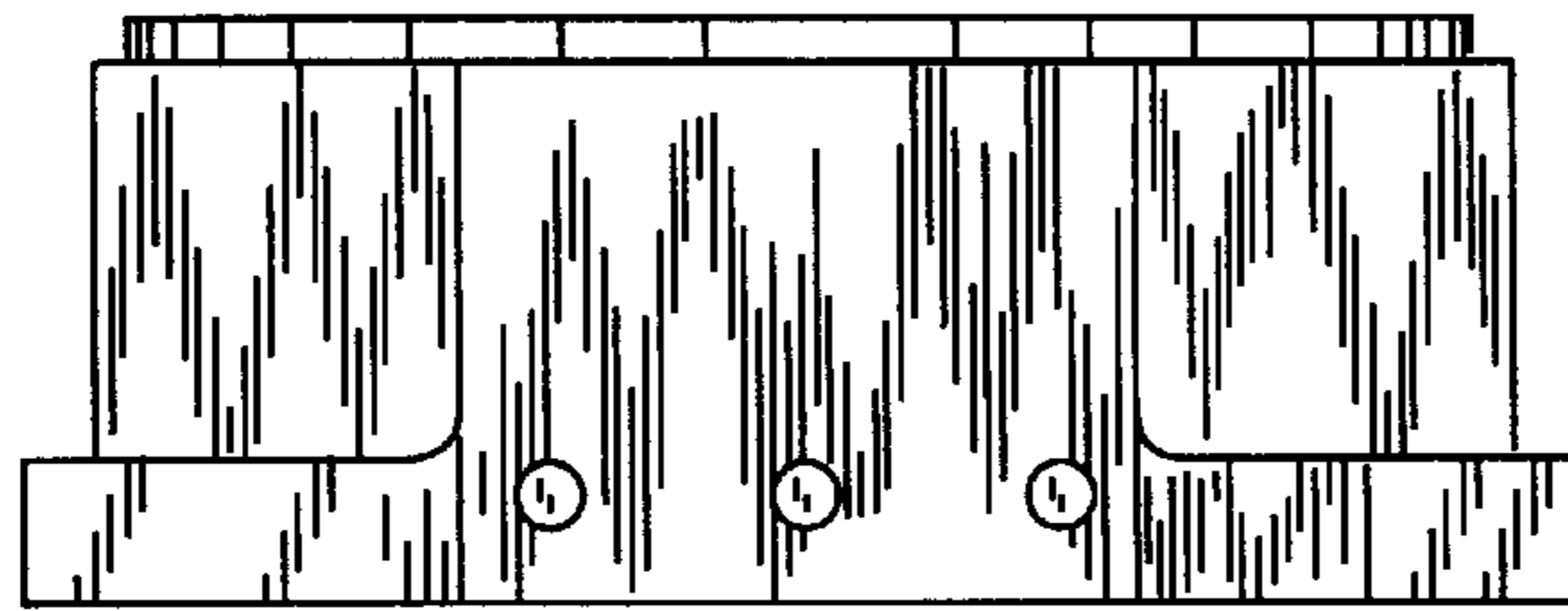

FIG. 6

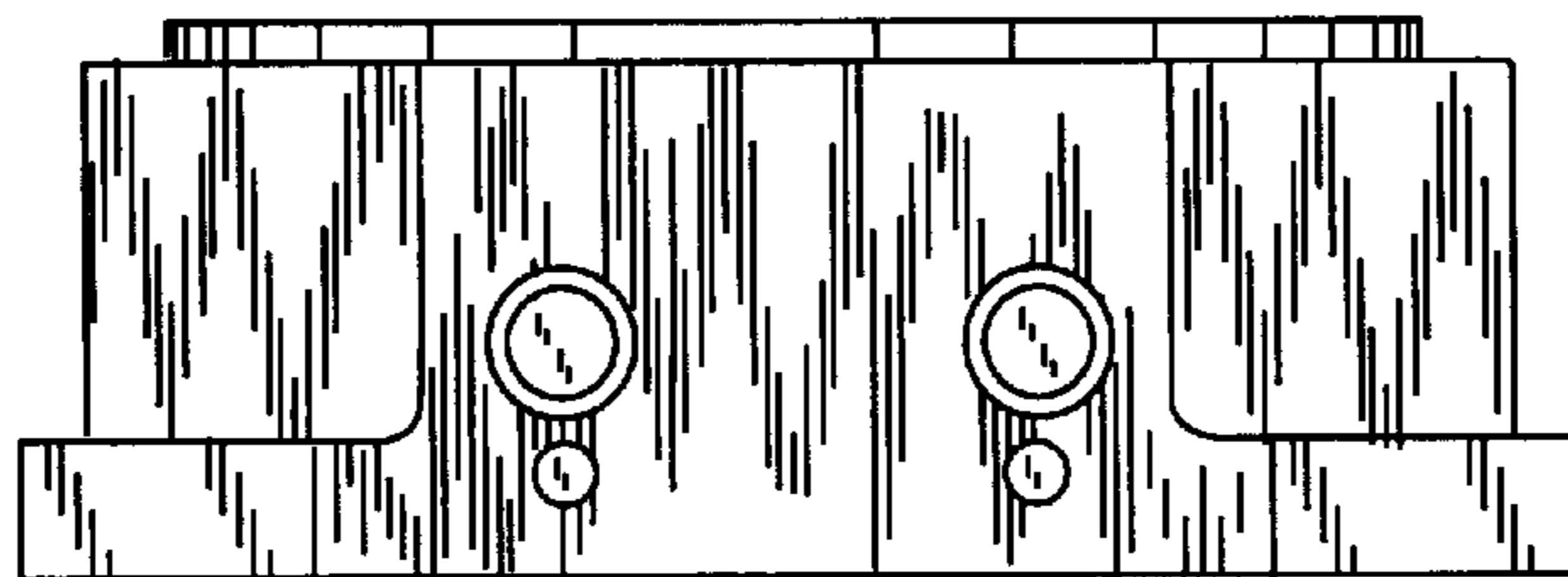

FIG. 7