



US00D531954S

(12) **United States Design Patent** (10) **Patent No.:** **US D531,954 S**  
**Eakins et al.** (45) **Date of Patent:** **\*\* Nov. 14, 2006**

(54) **JET AIRPLANE CONFIGURATION**

(56) **References Cited**

(75) Inventors: **Mark E. Eakins**, Kirkland, WA (US);  
**Paul Mikulencak**, Everett, WA (US);  
**R. Blake Emery**, Renton, WA (US);  
**Victor K. Stuhr**, Seattle, WA (US);  
**Adam P. Malachowski**, Lynwood, WA  
(US); **Stephen T. Brown**, Everett, WA  
(US); **Richard K. Wong**, Auburn, WA  
(US); **Chester P. Nelson**, Kirkland, WA  
(US); **Michael L. Drake**, Bellevue, WA  
(US); **Christopher A. Vegter**, Bothell,  
WA (US); **Bruce R. Detert**, Seattle, WA  
(US); **Christopher A. Konings**,  
Lynwood, WA (US)

U.S. PATENT DOCUMENTS

D354,474 S	*	1/1995	Murphy et al. ....	D12/340
D491,875 S	*	6/2004	Eatkins et al. ....	D12/319
D495,653 S	*	9/2004	Eatkins et al. ....	D12/319
D499,688 S	*	12/2004	Atkinson et al. ....	D12/319
D500,980 S	*	1/2005	Eatkins et al. ....	D12/319
D515,012 S	*	2/2006	Eatkins et al. ....	D12/319
D516,995 S	*	3/2006	Eatkins et al. ....	D12/319

\* cited by examiner

*Primary Examiner*—Marcus A. Jackson  
(74) *Attorney, Agent, or Firm*—Ostrager Chong Flaherty & Broitman P.C.

(73) Assignee: **The Boeing Company**, Chicago, IL  
(US)

(\*\*) Term: **14 Years**

(21) Appl. No.: **29/236,422**

(22) Filed: **Aug. 16, 2005**

**Related U.S. Application Data**

(63) Continuation-in-part of application No. 29/220,256, filed on  
Dec. 28, 2004, now Pat. No. Des. 515,013.

(51) **LOC (8) Cl.** ..... **12-12**

(52) **U.S. Cl.** ..... **D12/319**

(58) **Field of Classification Search** ..... D12/319-345;  
244/35 R, 45 R, 118.5, 119, 130

See application file for complete search history.

(57) **CLAIM**

The ornamental design for a jet airplane configuration, as shown and described.

**DESCRIPTION**

FIG. 1 is a top plan view of the jet airplane;  
FIG. 2 is a view of one side of the jet airplane, with the  
opposite side being a mirror image thereof;  
FIG. 3 is a front plan view of the jet airplane;  
FIG. 4 is a back plan view of the jet airplane; and,  
FIG. 5 is a bottom plan view of the jet airplane.

**1 Claim, 3 Drawing Sheets**

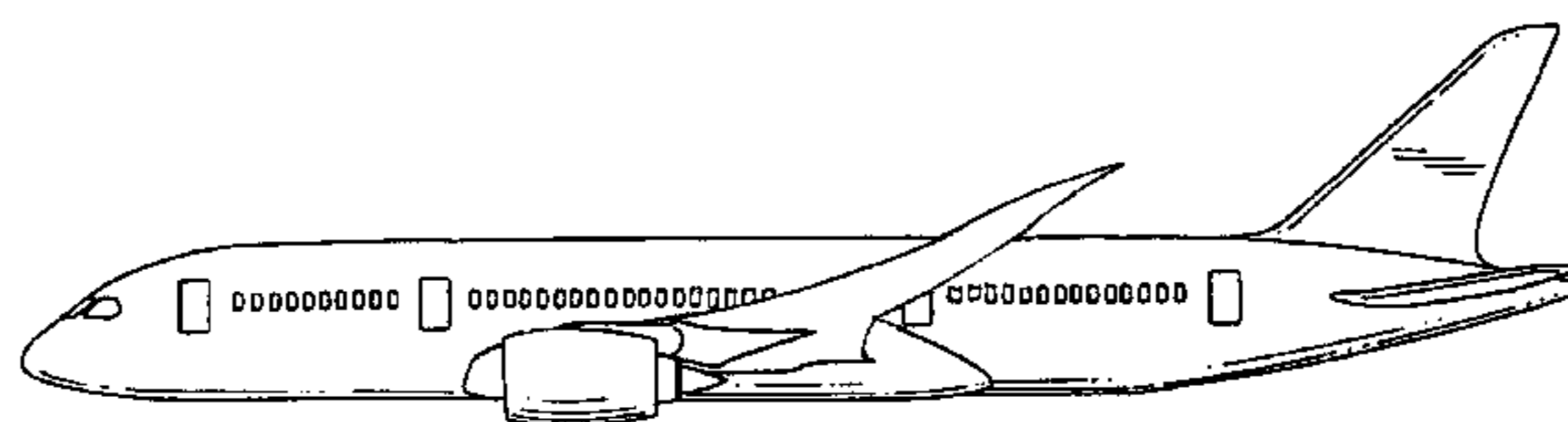
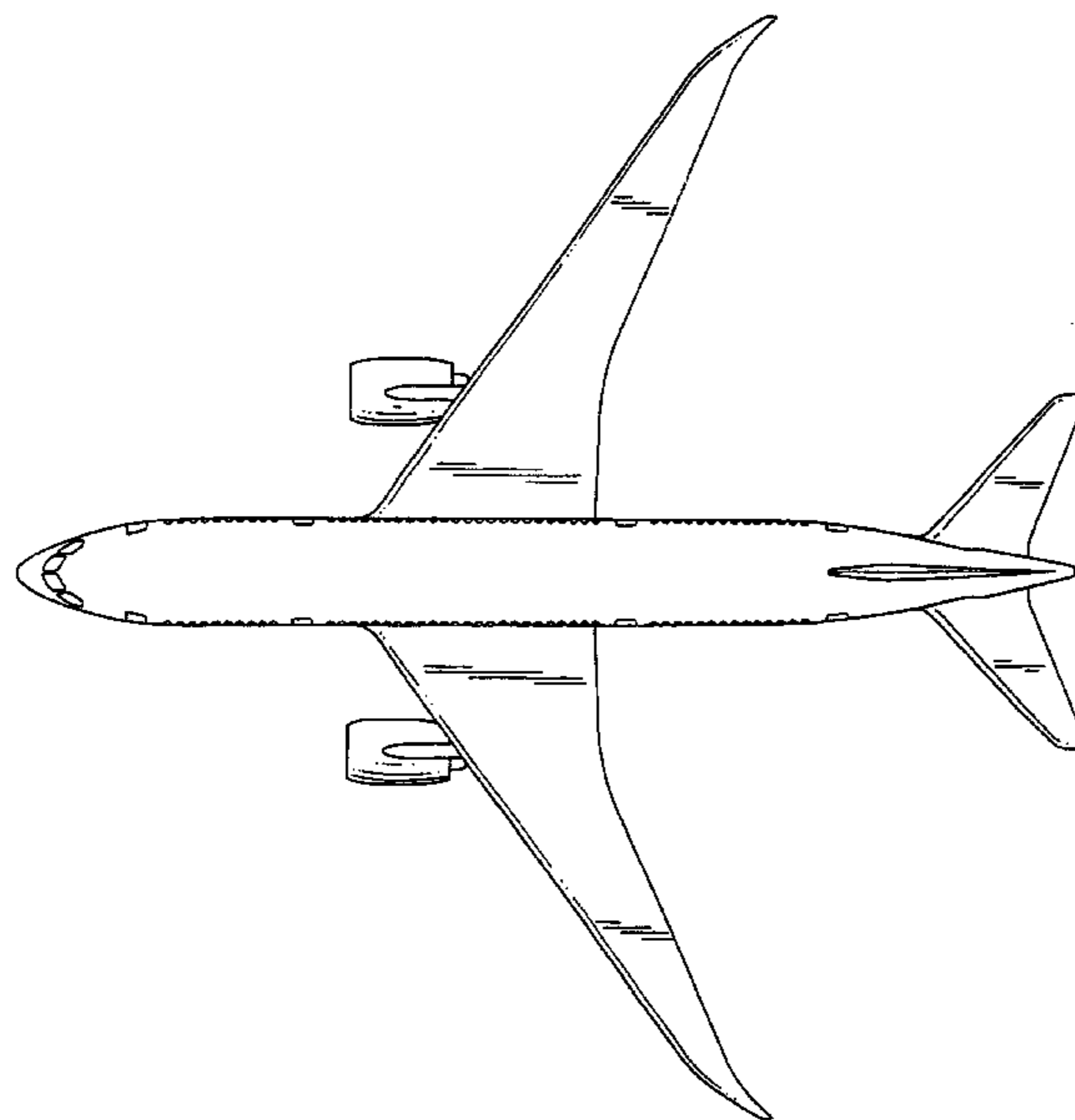

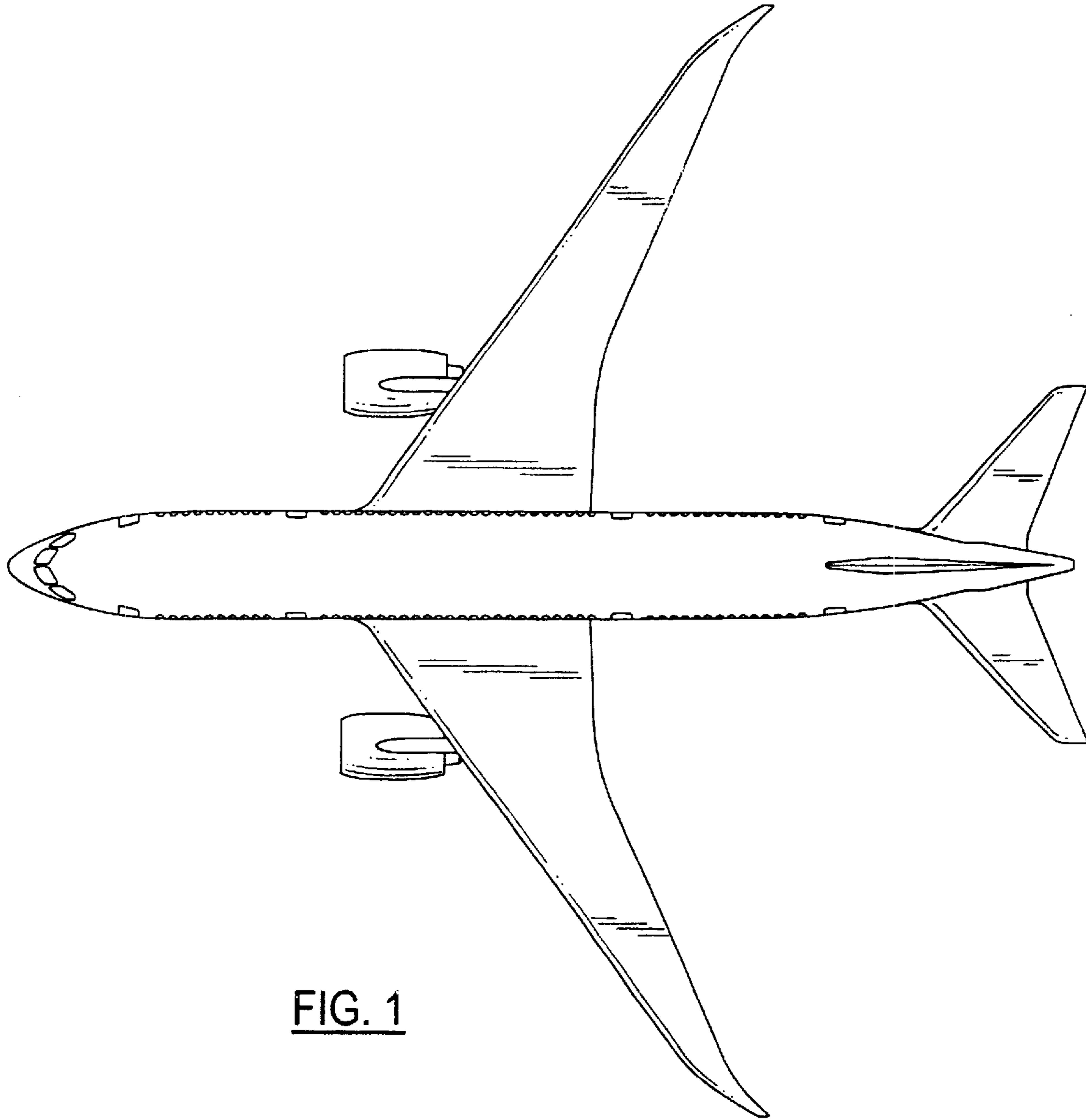

FIG. 1

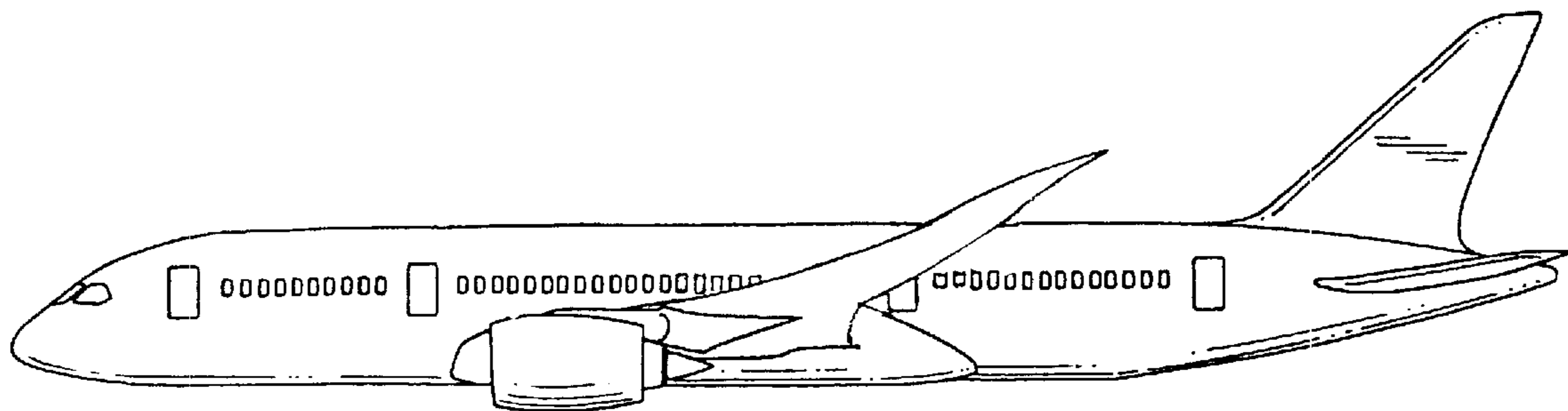

FIG. 2

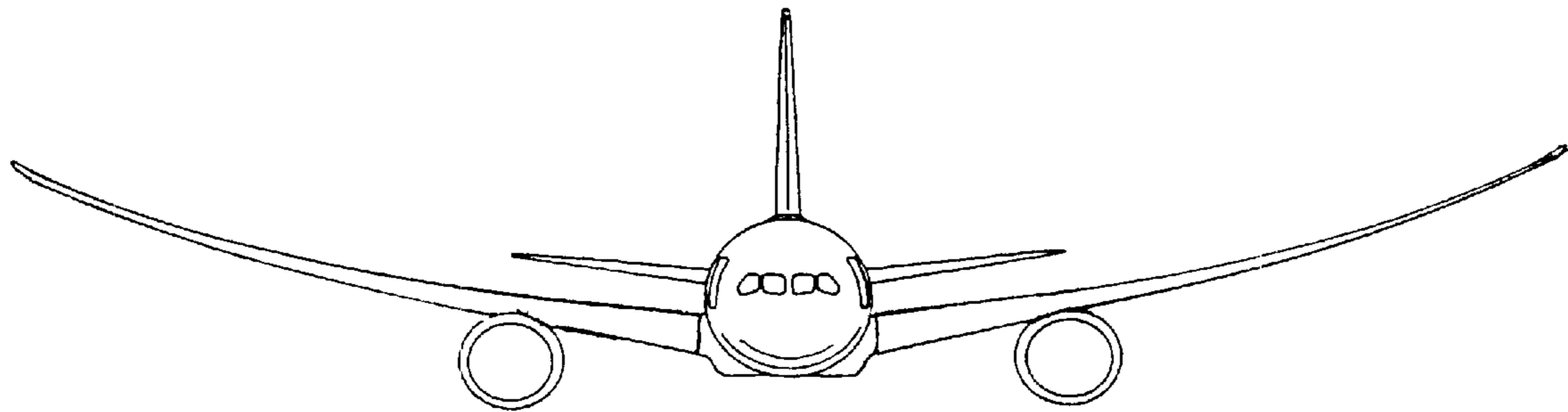

FIG. 3

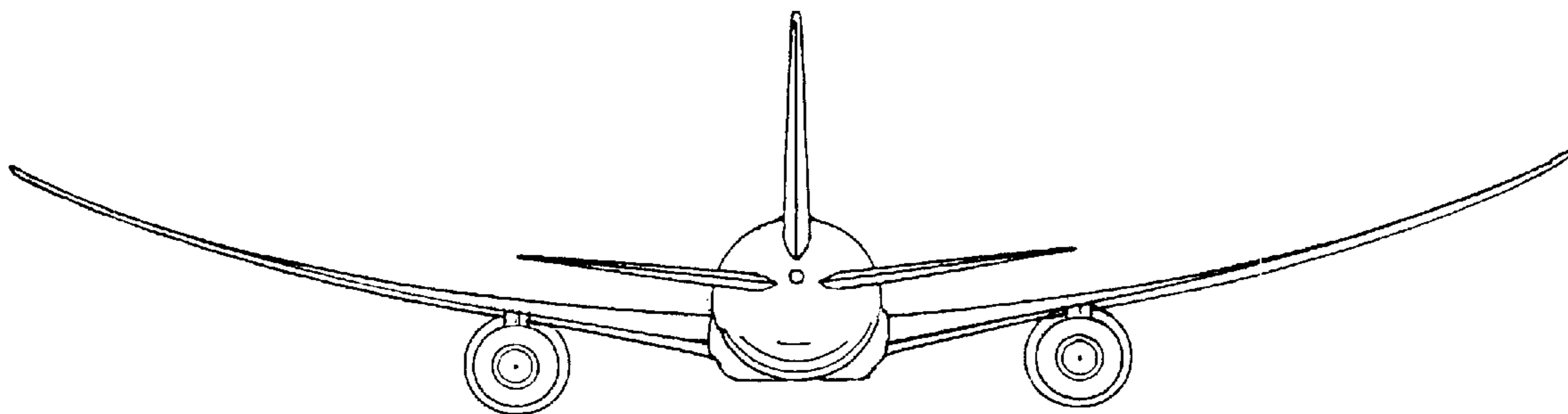

FIG. 4

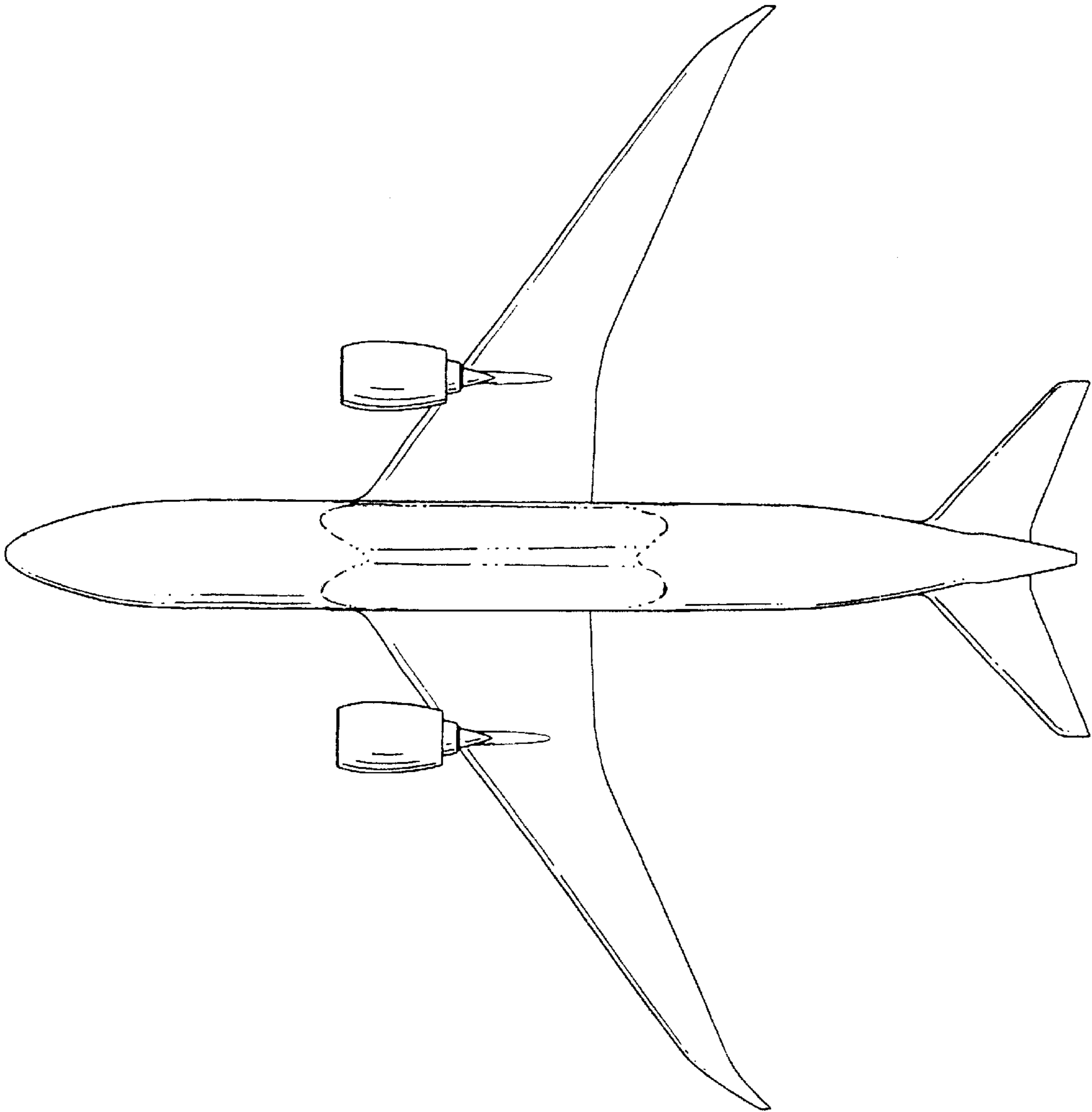

FIG. 5