



US00D531936S

(12) **United States Design Patent**
Ito et al.

(10) **Patent No.:** **US D531,936 S**

(45) **Date of Patent:** **** Nov. 14, 2006**

(54) **MOTORCYCLE**

(75) Inventors: **Masamoto Ito**, Wako (JP); **Kenji Tamura**, Wako (JP); **Teofiro Plaza**, Rome (IT)

(73) Assignee: **Honda Motor Co., Ltd.**, Tokyo (JP)

(**) Term: **14 Years**

(21) Appl. No.: **29/230,824**

(22) Filed: **May 27, 2005**

(30) **Foreign Application Priority Data**

Nov. 29, 2004 (JP) 2004-036391

(51) **LOC (8) Cl.** **12-11**

(52) **U.S. Cl.** **D12/110**

(58) **Field of Classification Search** D12/110;
180/219, 220, 225, 229

See application file for complete search history.

(56) **References Cited**

U.S. PATENT DOCUMENTS

D321,676 S * 11/1991 Kitagawa et al. D12/110

D470,800 S * 2/2003 Muta et al. D12/110

FOREIGN PATENT DOCUMENTS

JP 1040177 6/1999

JP 1143907 6/2002

* cited by examiner

Primary Examiner—Alan P. Douglas

Assistant Examiner—Linda Brooks

(74) *Attorney, Agent, or Firm*—Arent Fox PLLC

(57) **CLAIM**

The ornamental design for a motorcycle, as shown and described.

DESCRIPTION

FIG. 1 is a front view of a motorcycle showing my new design.

FIG. 2 is a rear view thereof.

FIG. 3 is a plan view thereof.

FIG. 4 is a bottom view thereof.

FIG. 5 is a right side view thereof.

FIG. 6 is a left side view thereof.

FIG. 7 is a perspective view thereof as seen from the right front side.

FIG. 8 is a perspective view thereof as seen from the left front side.

FIG. 9 is a perspective view thereof as seen from the left rear side.

FIG. 10 is a perspective view thereof as seen from the right rear side; and,

FIG. 11 is a reference front perspective view thereof with the rear bag opening on the left rear side thereof.

1 Claim, 6 Drawing Sheets

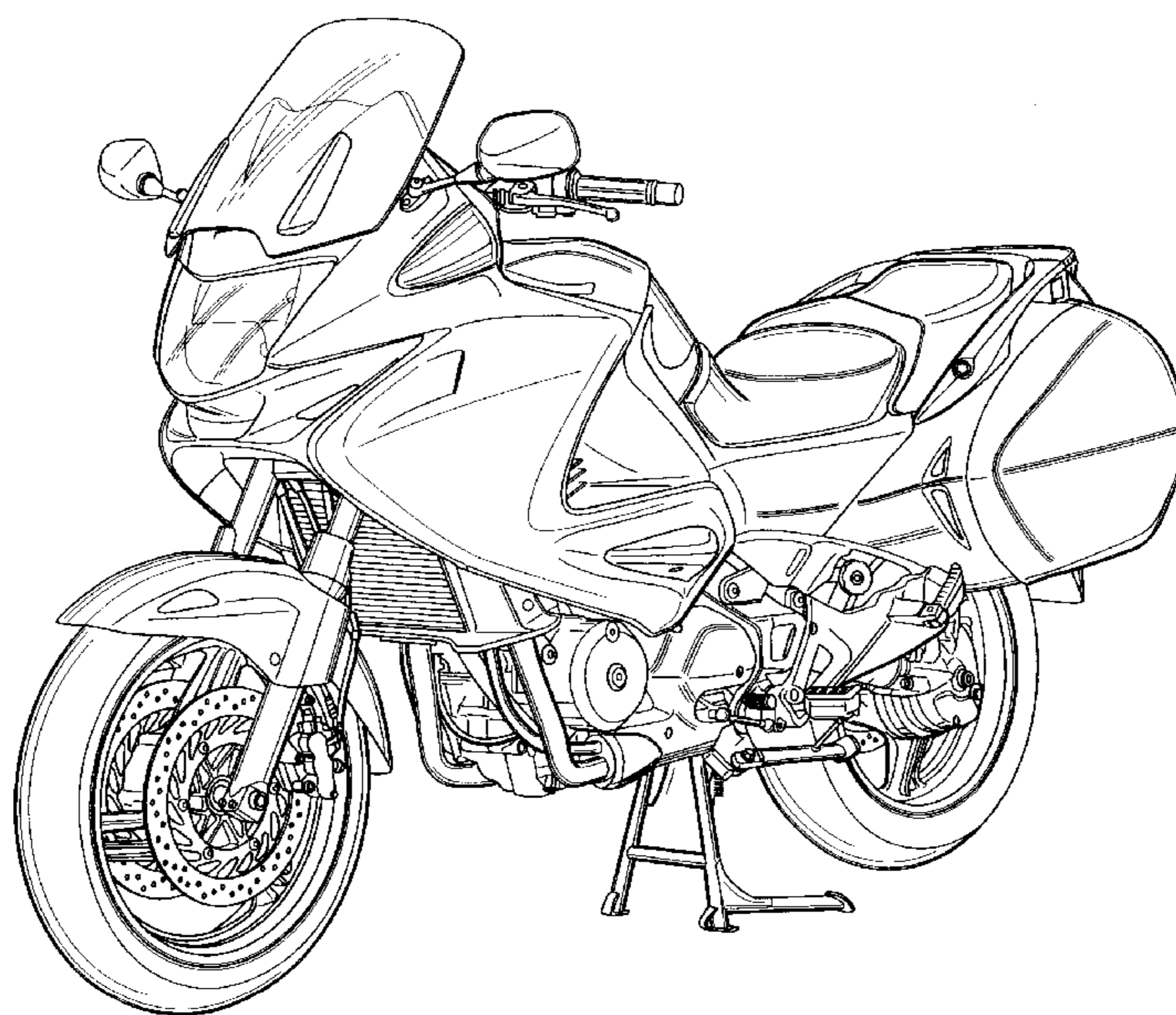

FIG.1

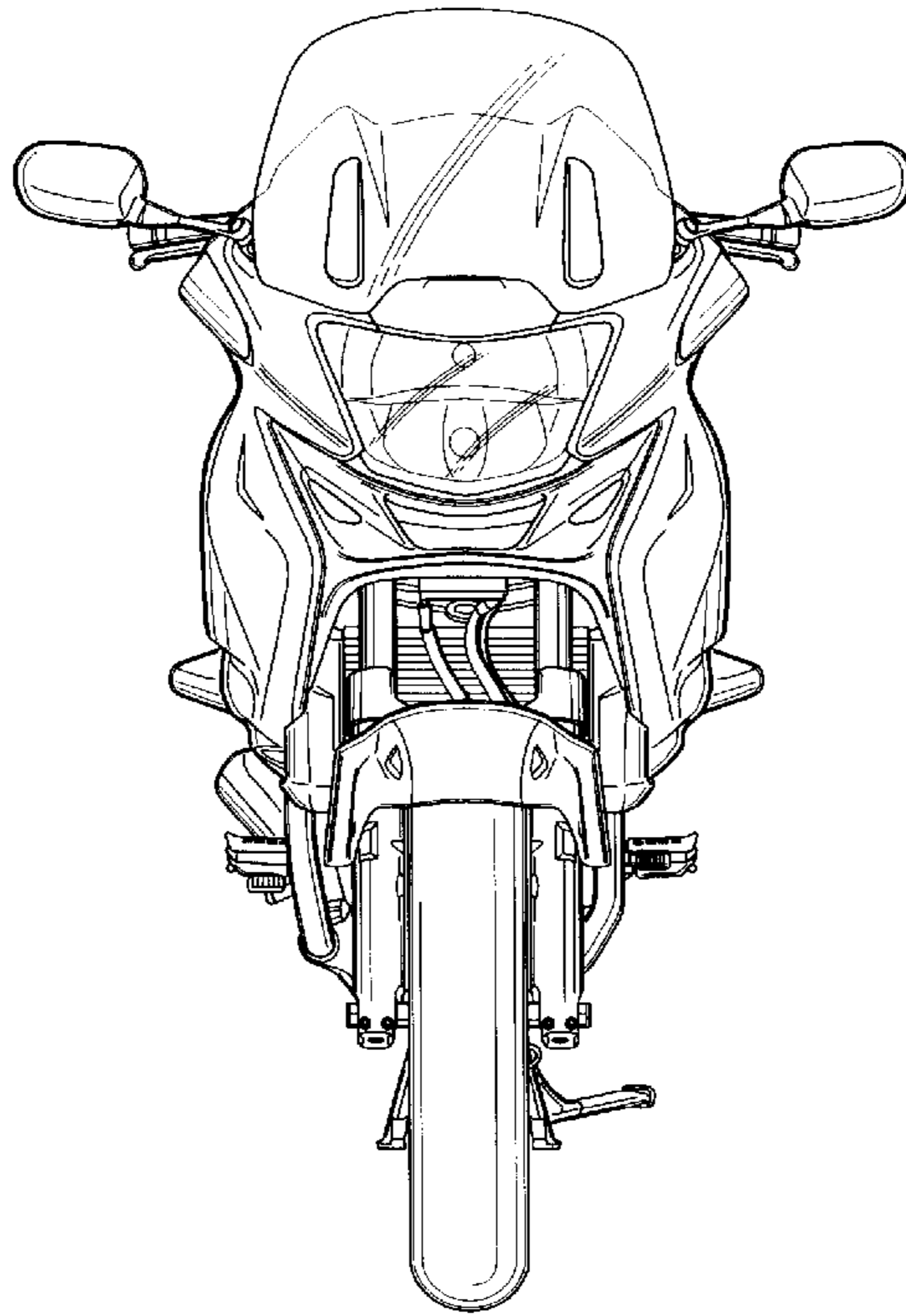

FIG.2

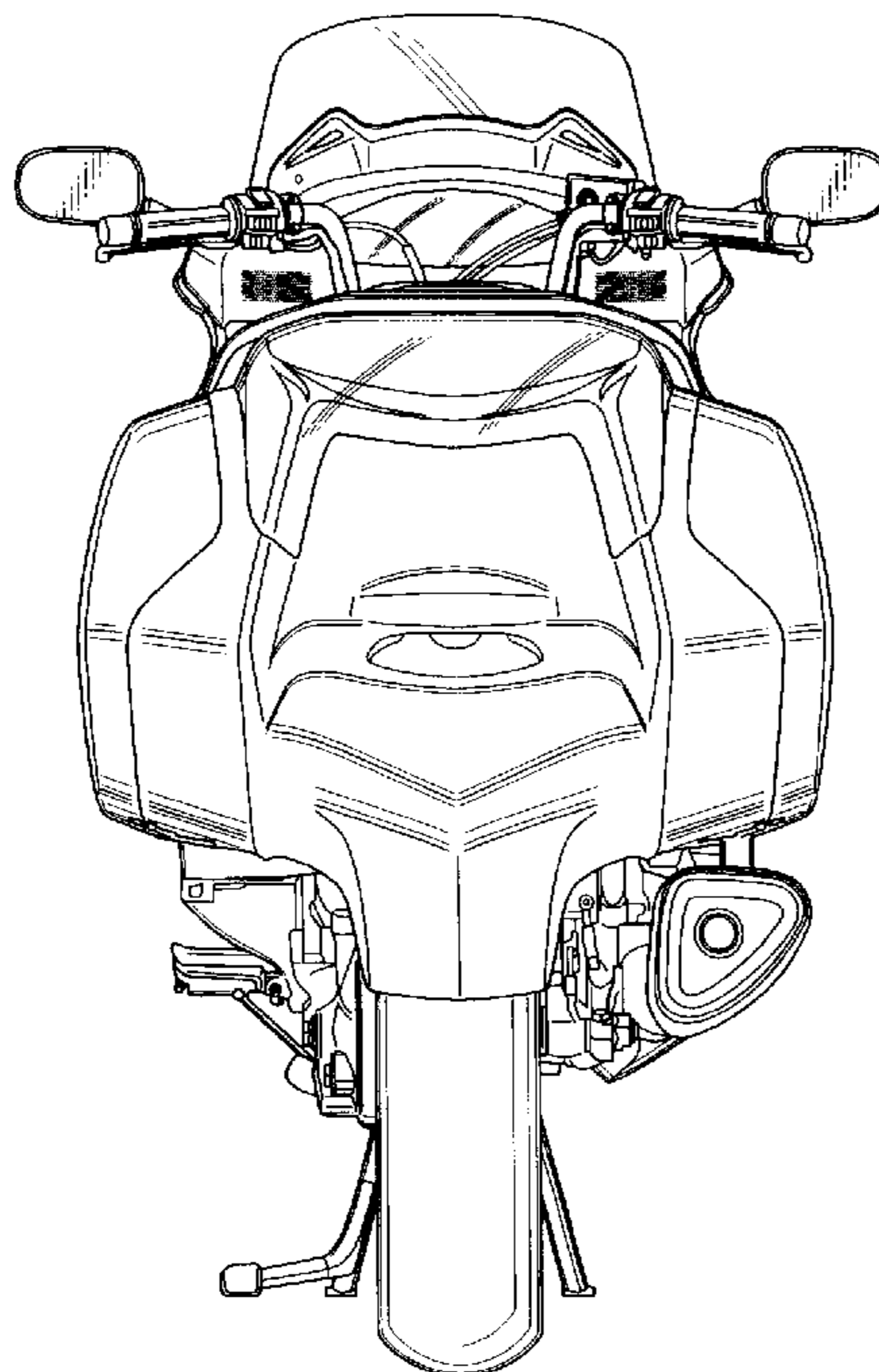

FIG.3

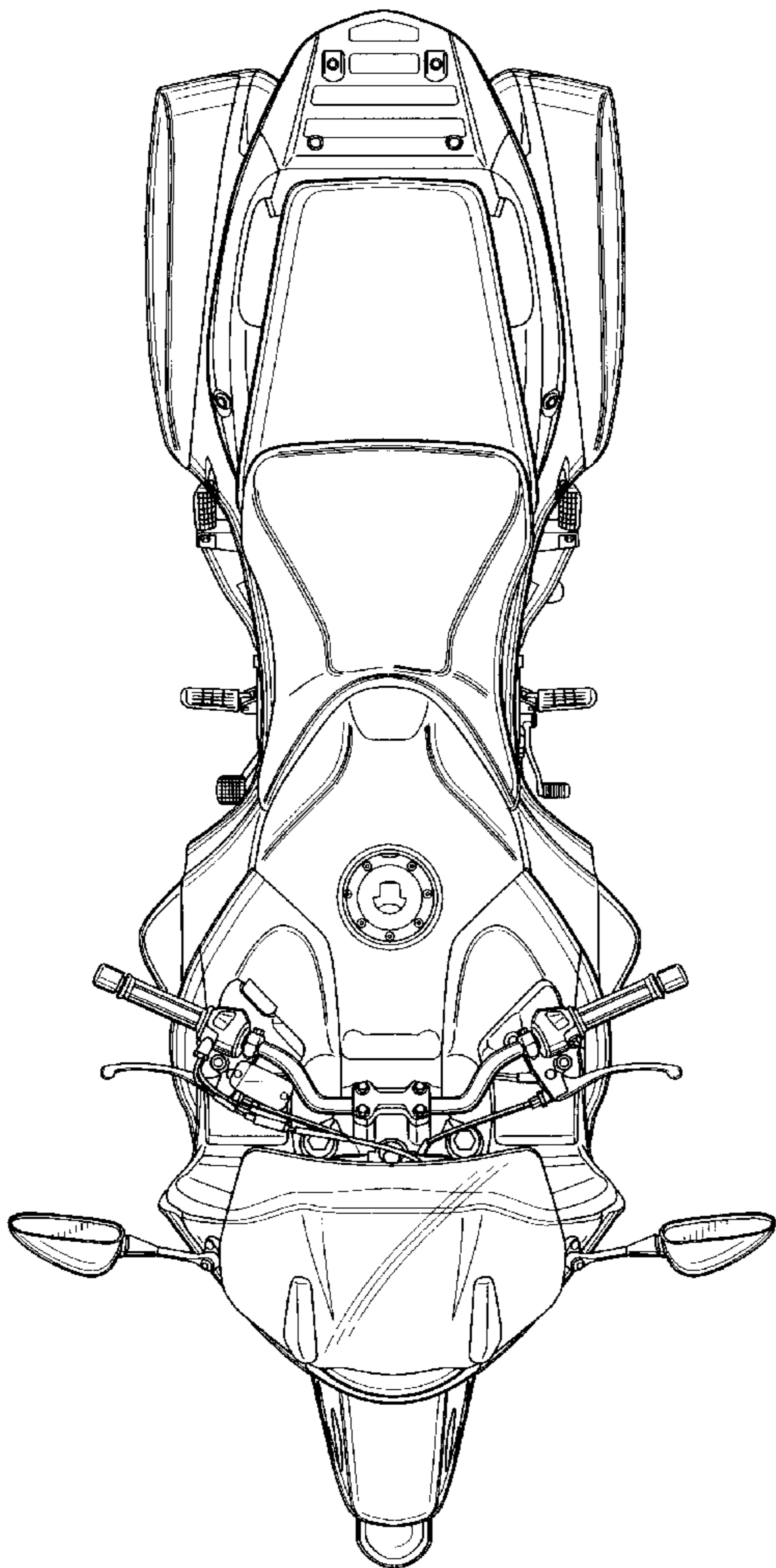

FIG.4

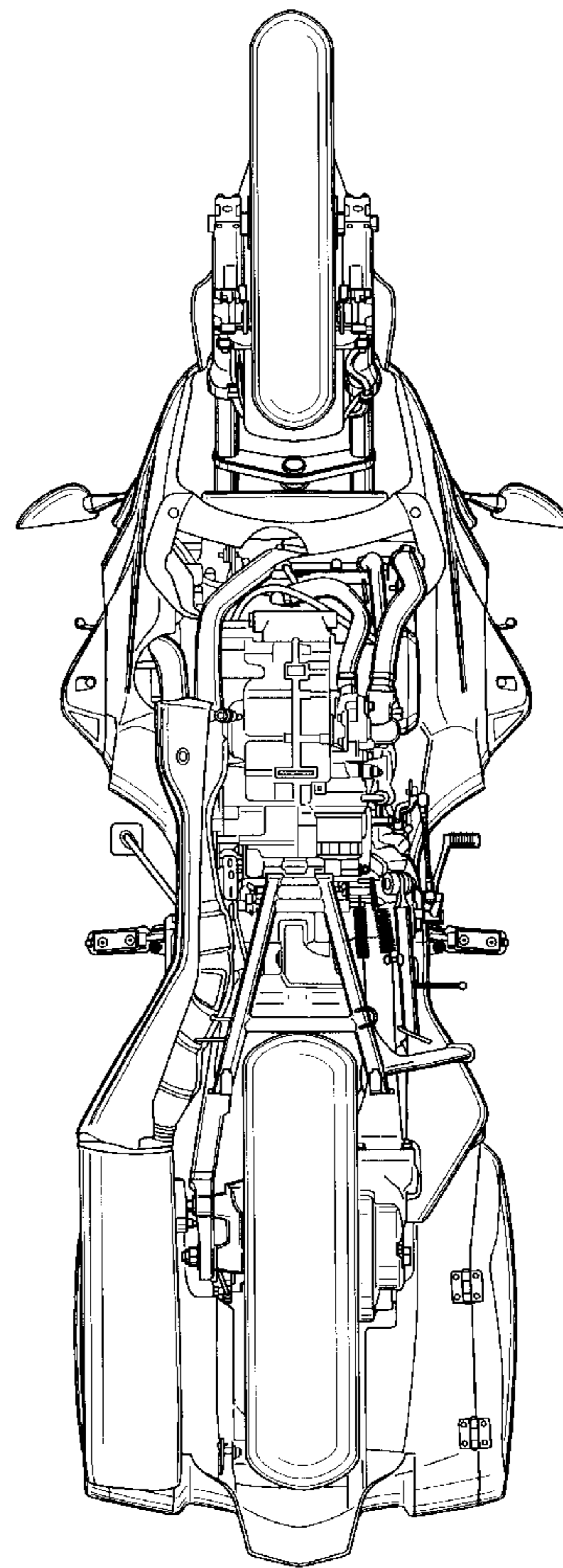

FIG.5

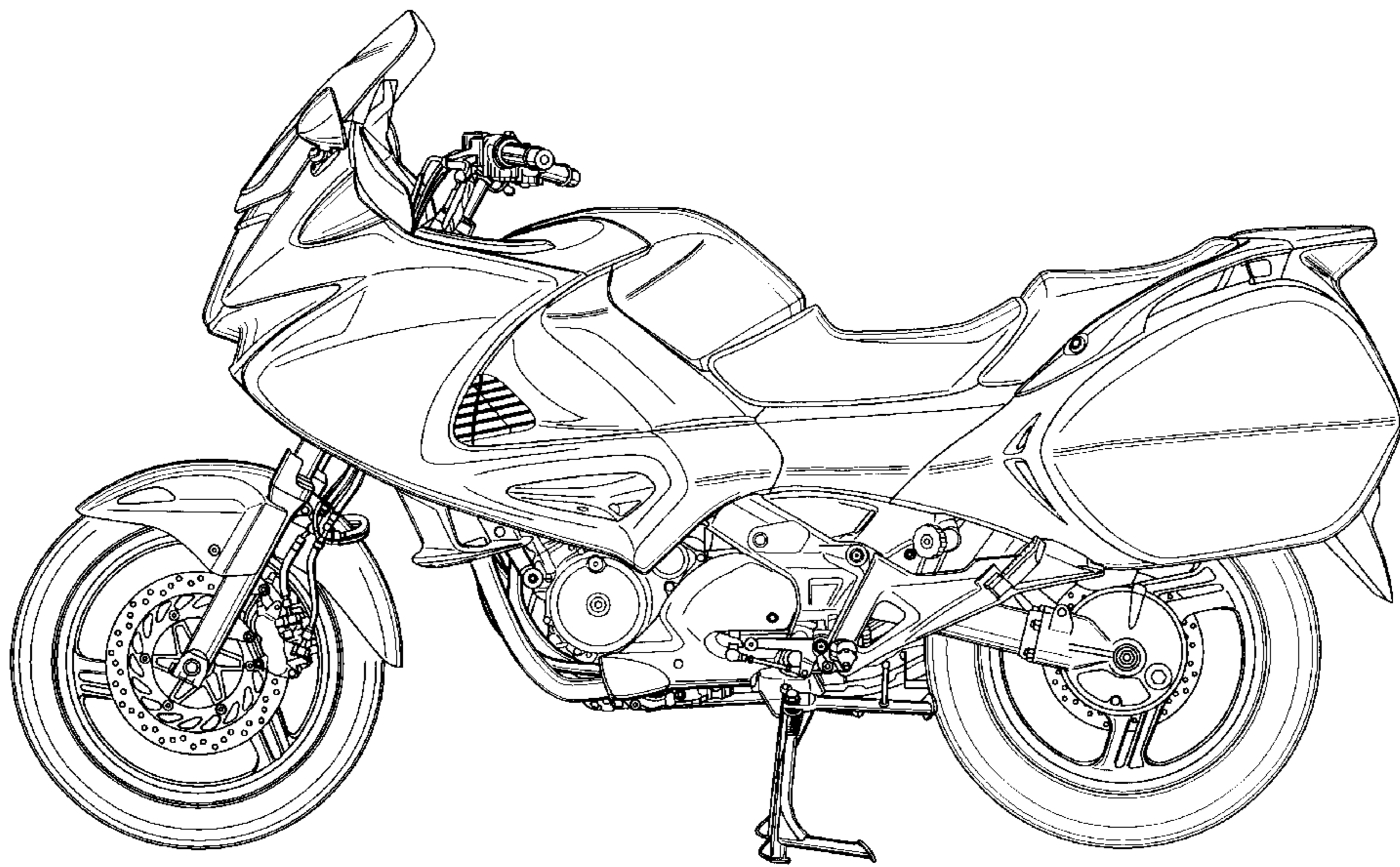

FIG.6

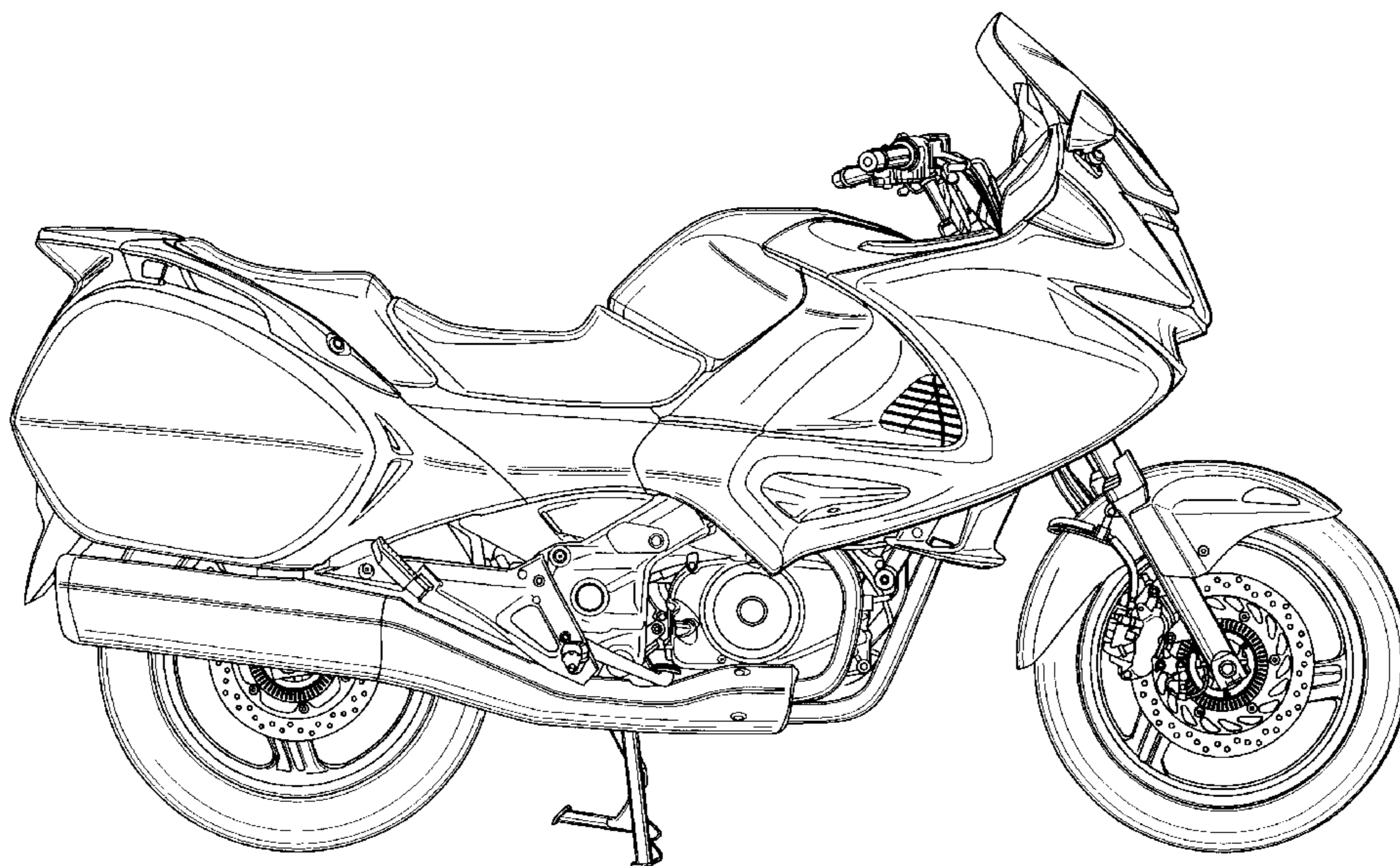

FIG.7

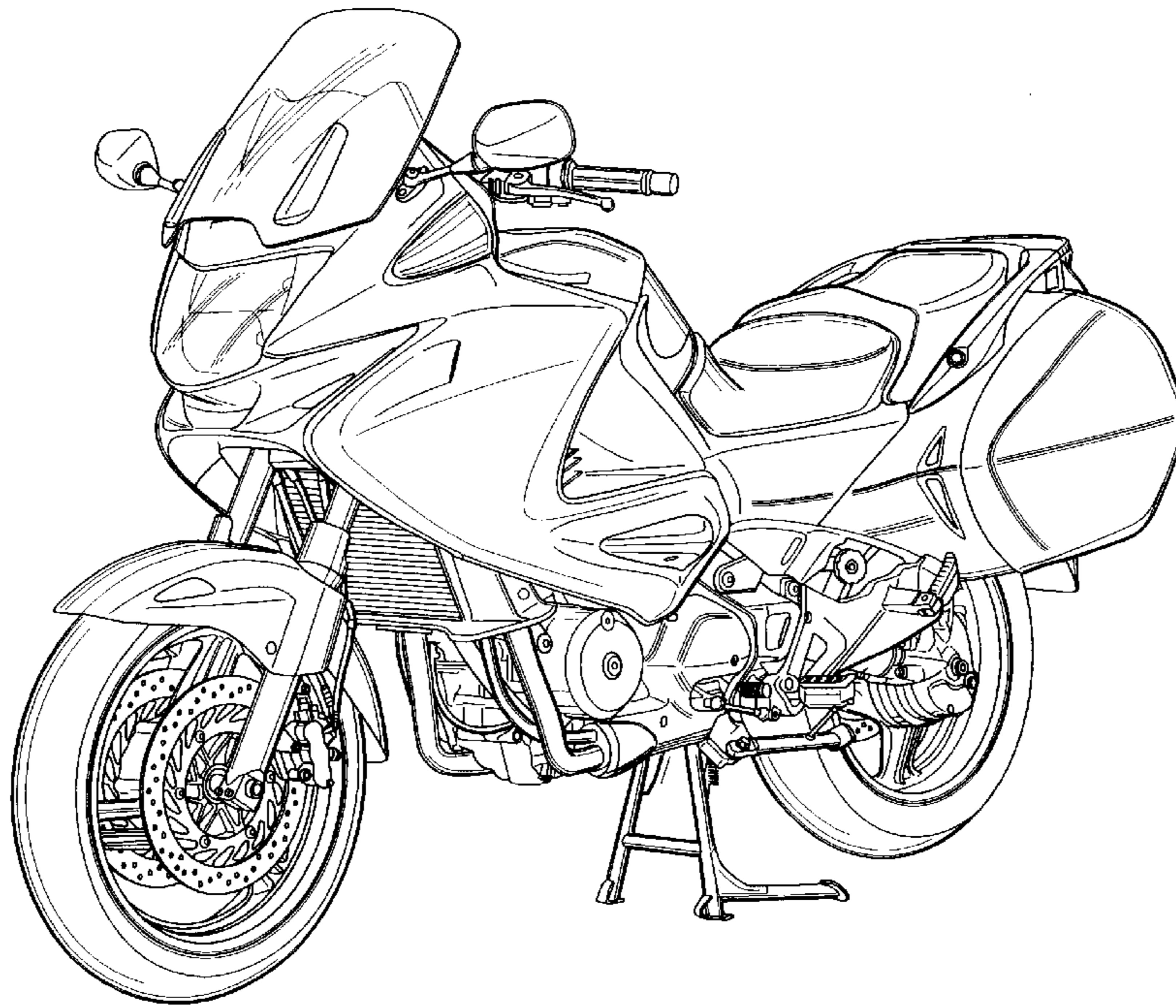

FIG.8

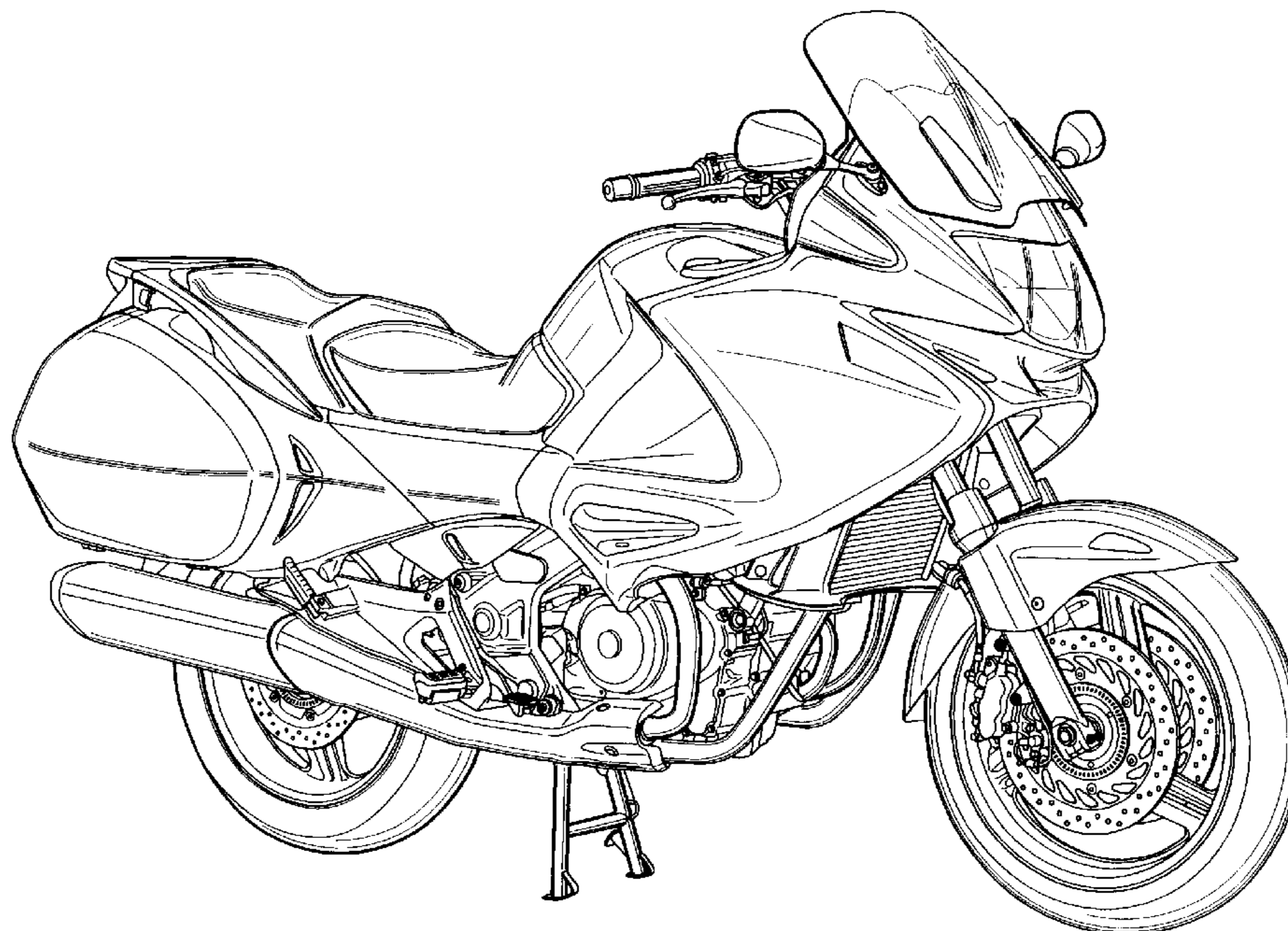

FIG.9

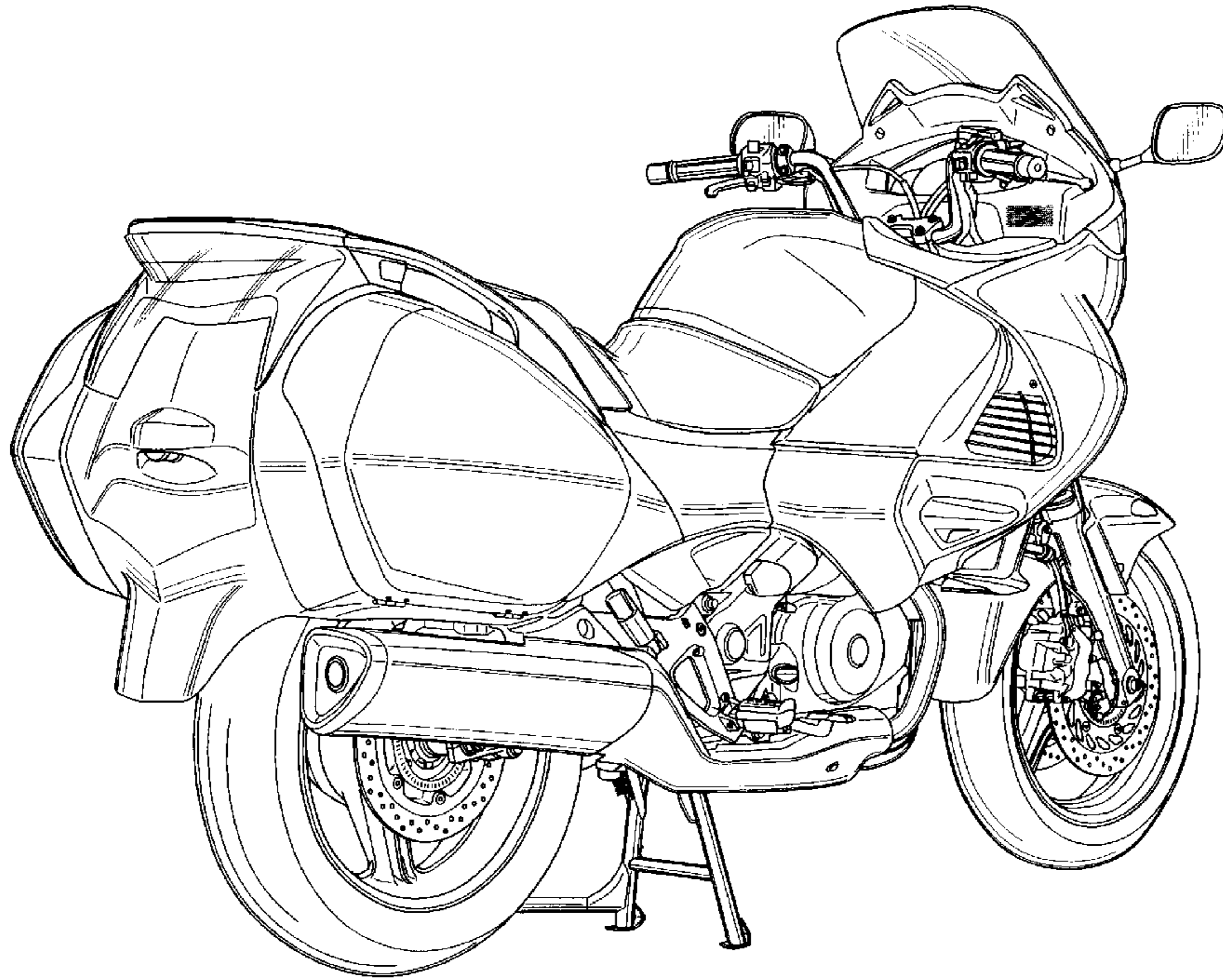

FIG.10

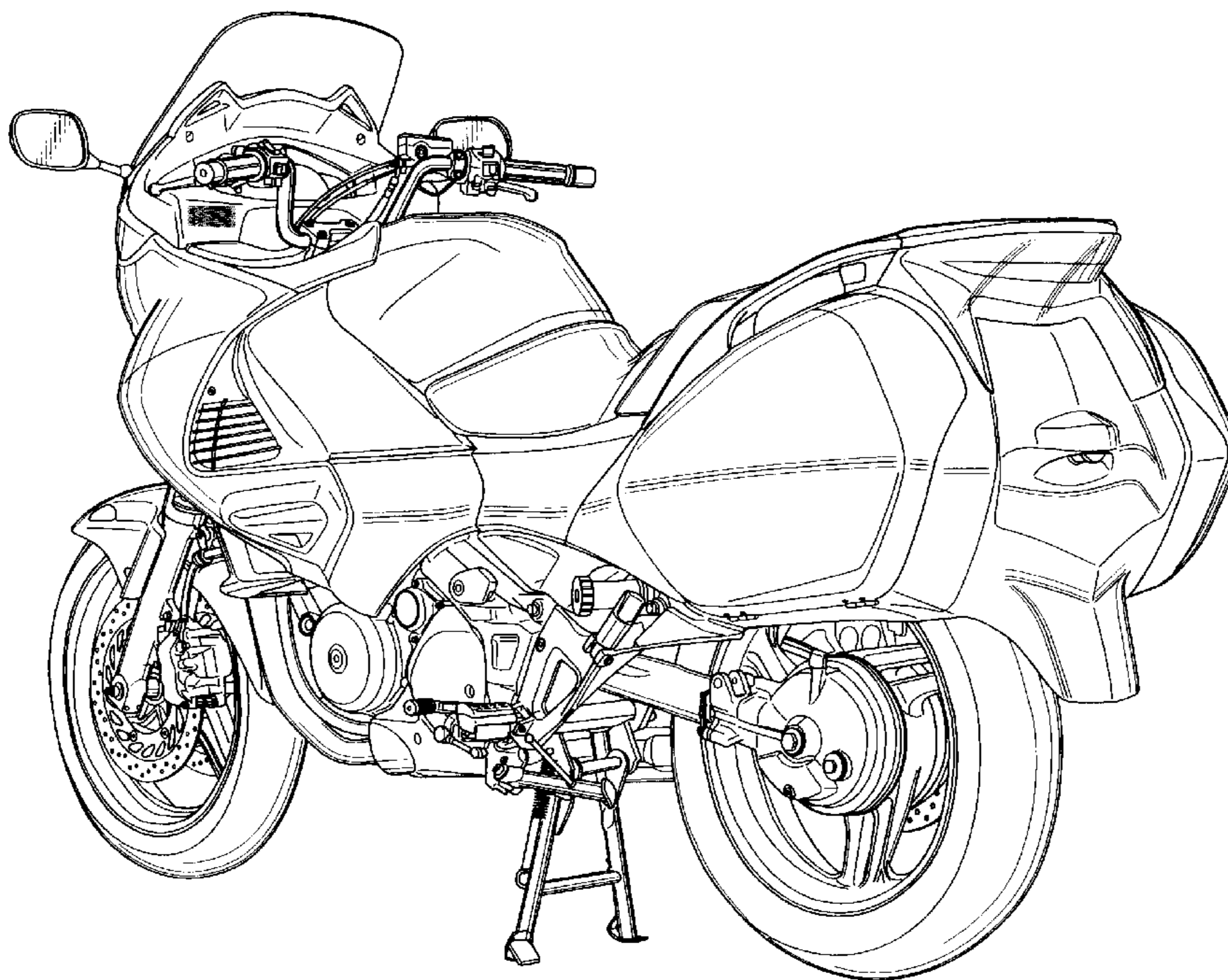

FIG.11

