



US00D531872S

(12) **United States Design Patent**
Aglassinger

(10) **Patent No.:** **US D531,872 S**

(45) **Date of Patent:** **** Nov. 14, 2006**

(54) **BATTERY OPERATED SCREWDRIVER**

(75) Inventor: **Hans-Peter Aglassinger**, Esslingen
(DE)

(73) Assignee: **Robert Bosch GmbH**, Stuttgart (DE)

(**) Term: **14 Years**

(21) Appl. No.: **29/220,819**

(22) Filed: **Jan. 6, 2005**

(30) **Foreign Application Priority Data**

Nov. 1, 2004 (DE) 4 04 06 187

(51) **LOC (8) Cl.** **08-04**

(52) **U.S. Cl.** **D8/68**

(58) **Field of Classification Search** 408/125,
408/234, 241 R, 20, 124; 451/358; 310/50;
227/8, 114, 120, 130, 136, 142; D8/14.1,
D8/61, 62, 63, 64, 65, 66, 67, 68, 69, 70;
81/57.11, 429, 464, 465, 466, 469, 489; 173/13,
173/104, 114, 168, 169, 170, 171, 178, 201,
173/211, 213, 217

See application file for complete search history.

(56) **References Cited**

U.S. PATENT DOCUMENTS

D136,743 S * 11/1943 Little D8/68
D154,713 S * 9/1949 Robillard D8/68
4,448,098 A * 5/1984 Totsu 81/57.11
D275,444 S * 9/1984 Totsu D8/68

D325,857 S * 5/1992 Hasegawa et al. D8/61
5,269,874 A * 12/1993 Winter 451/358
D403,936 S * 1/1999 Somers D8/68
D462,593 S * 9/2002 Nottingham et al. D8/68
D467,150 S * 12/2002 Frederick D8/68
D469,324 S * 1/2003 Heun D8/68
D475,909 S * 6/2003 Waldron D8/68
D485,737 S * 1/2004 Schaub et al. D8/68
D486,713 S * 2/2004 Lai D8/68
D502,854 S * 3/2005 Ng D8/68
D509,119 S * 9/2005 Schiller et al. D8/68
D513,160 S * 12/2005 DeBoer et al. D8/68
D516,889 S * 3/2006 Aglassinger D8/68
2004/0188119 A1 * 9/2004 Chen 173/217

* cited by examiner

Primary Examiner—T. Chase Nelson

(74) *Attorney, Agent, or Firm*—Michael J. Striker

(57) **CLAIM**

The ornamental design for a battery operated screwdriver, as shown and described.

DESCRIPTION

FIG. 1 is a perspective view of a battery operated screwdriver showing my new design;
FIG. 2 is a bottom view thereof;
FIG. 3 is a side view thereof;
FIG. 4 is a top view thereof;
FIG. 5 is the opposite side view of FIG. 3 thereof;
FIG. 6 is a front view thereof; and,
FIG. 7 is a rear view thereof.

1 Claim, 7 Drawing Sheets

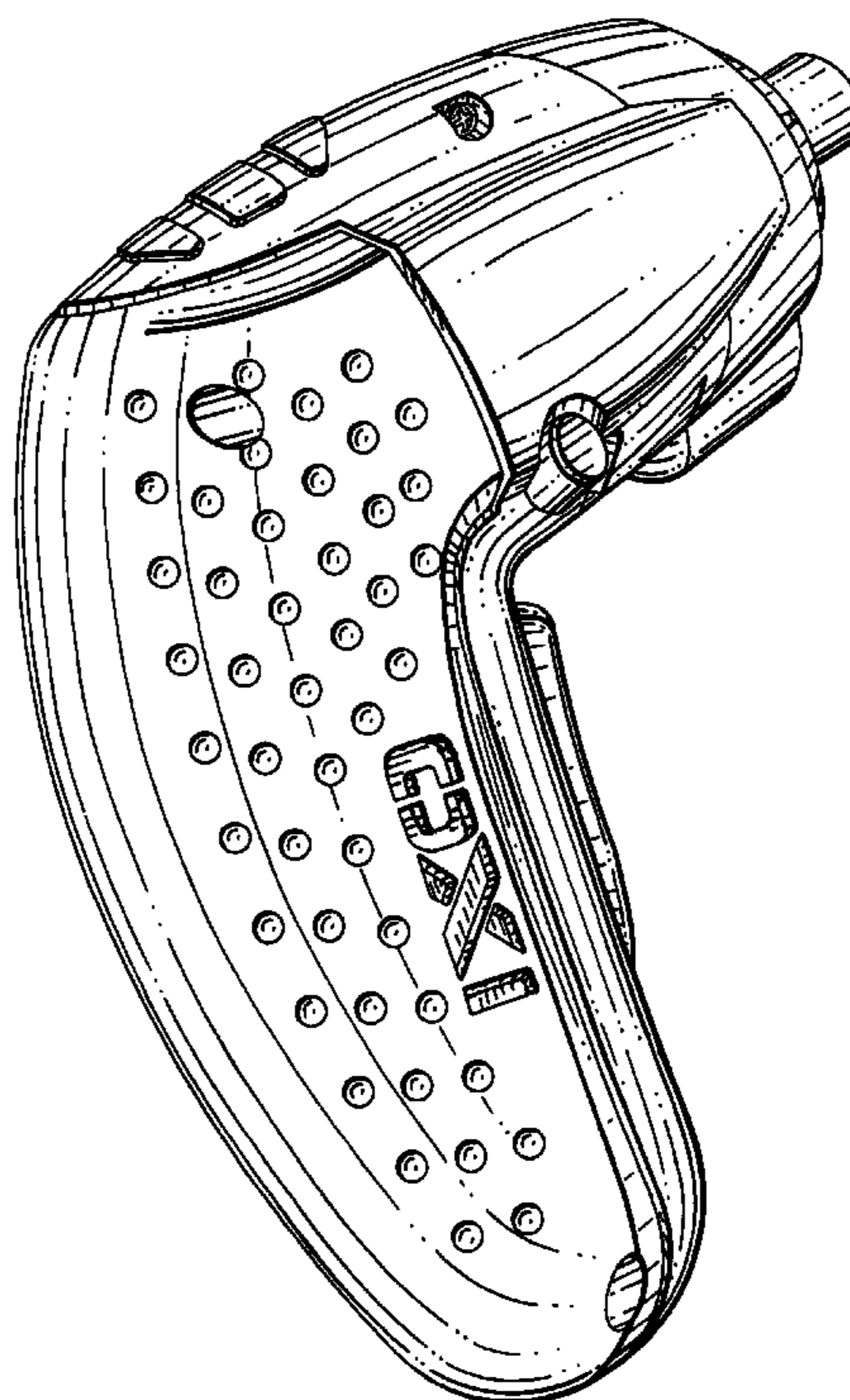

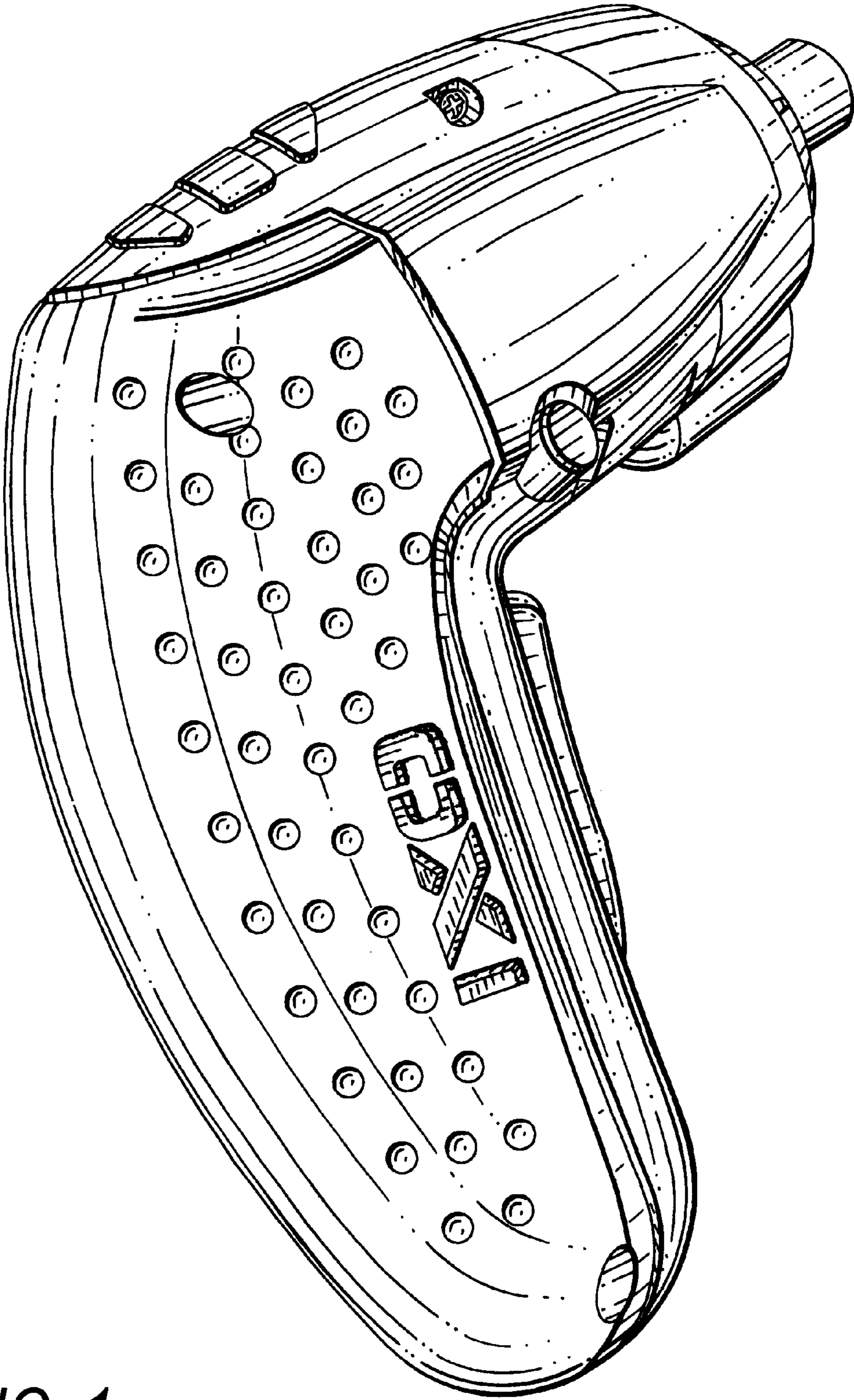

FIG. 1

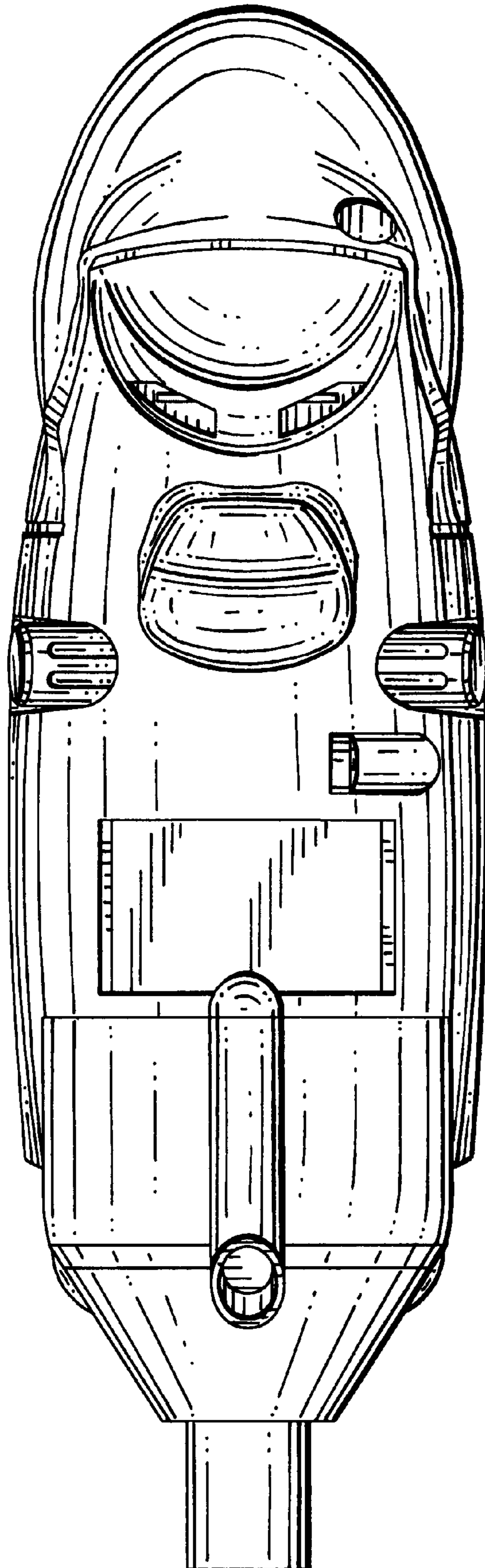

FIG. 2

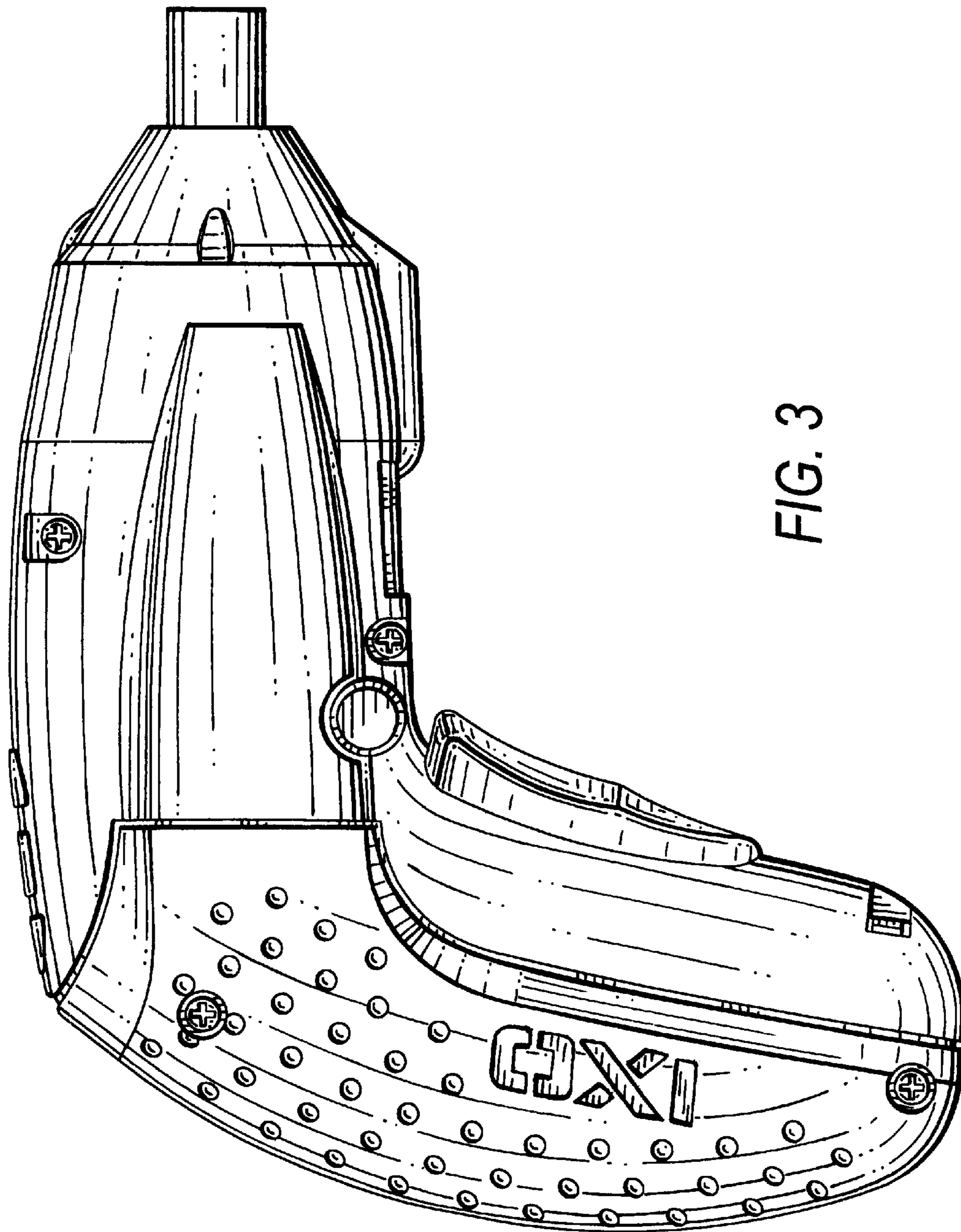

FIG. 3

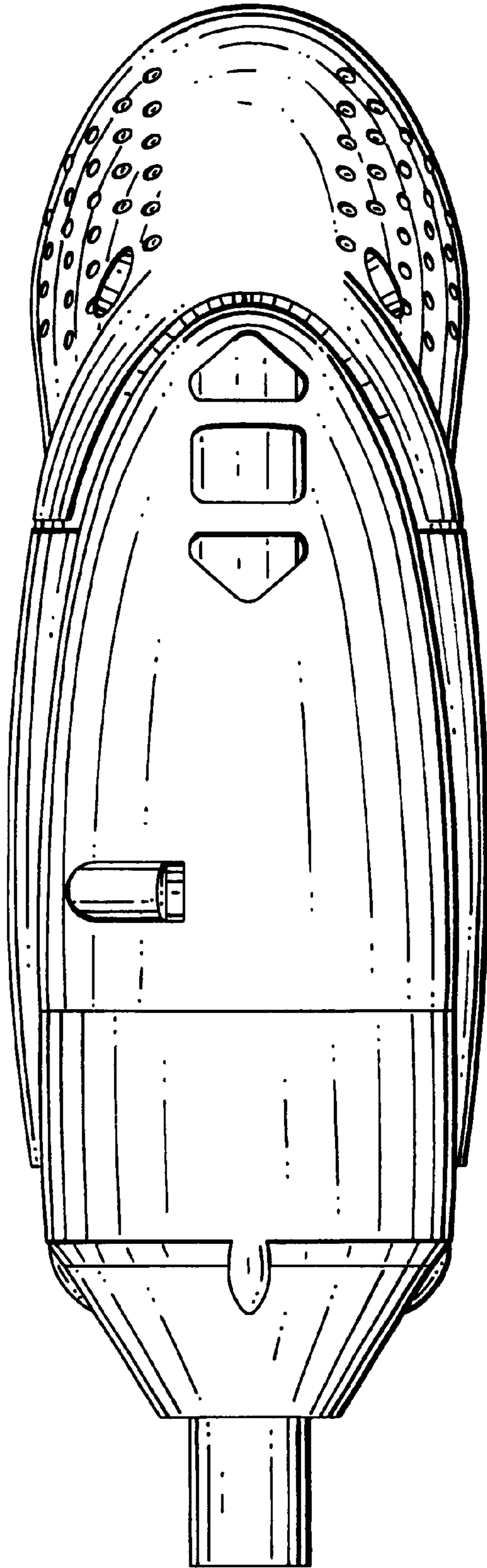

FIG. 4

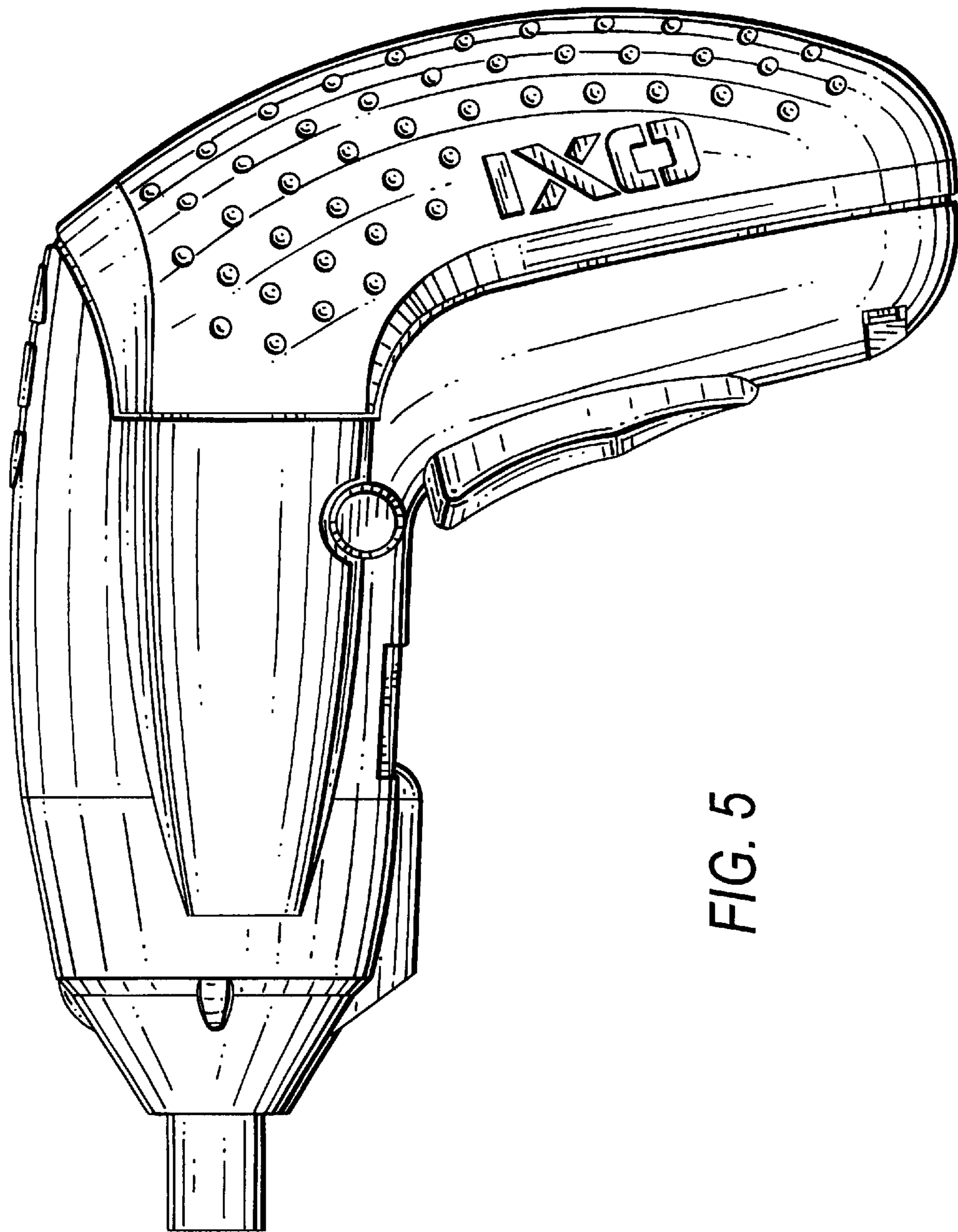

FIG. 5

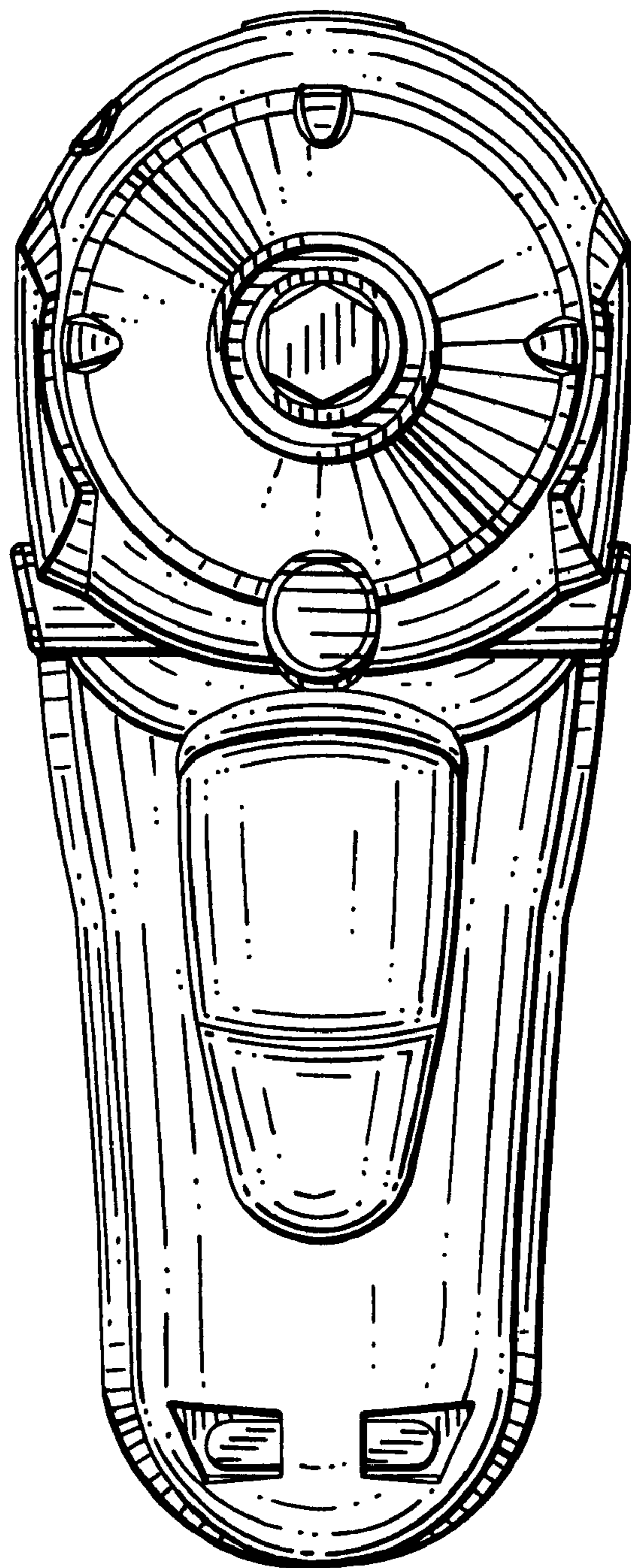

FIG. 6

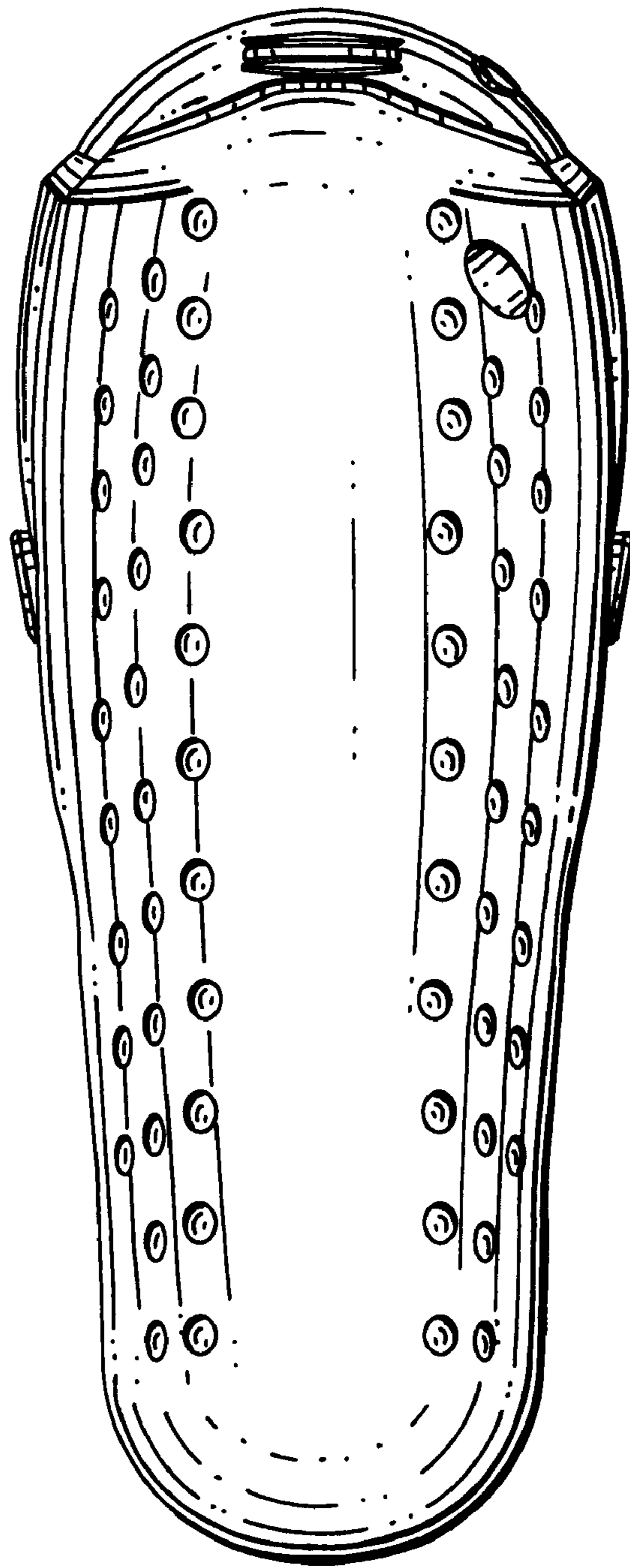

FIG. 7