



US00D531551S

(12) **United States Design Patent**
Takeda

(10) **Patent No.:** **US D531,551 S**

(45) **Date of Patent:** **** Nov. 7, 2006**

(54) **MOTORCYCLE**

D499,671 S * 12/2004 Uemoto et al. D12/110

(75) Inventor: **Susumu Takeda**, Tokyo-to (JP)

* cited by examiner

(73) Assignee: **Yamaha Hatsudoki Kabushiki Kaisha**
(JP)

Primary Examiner—Alan P. Douglas

Assistant Examiner—Linda Brooks

(**) Term: **14 Years**

(74) *Attorney, Agent, or Firm*—Ostrolenk, Faber, Gerb & Soffen, LLP

(21) Appl. No.: **29/237,398**

(57) **CLAIM**

(22) Filed: **Aug. 31, 2005**

The ornamental design for a motorcycle, as shown.

(51) **LOC (8) Cl.** **12-11**

(52) **U.S. Cl.** **D12/110**

(58) **Field of Classification Search** D12/110;
180/219, 220, 225, 229

DESCRIPTION

See application file for complete search history.

FIG. 1 is front, left side perspective view of a motorcycle showing my new design;

FIG. 2 is a left side view thereof;

FIG. 3 is a right side view thereof;

FIG. 4 is a front view thereof;

FIG. 5 is a rear view thereof;

FIG. 6 is a top plan view thereof; and,

FIG. 7 is a bottom view thereof.

(56) **References Cited**

U.S. PATENT DOCUMENTS

D496,309 S * 9/2004 Fukumoto et al. D12/110

1 Claim, 4 Drawing Sheets

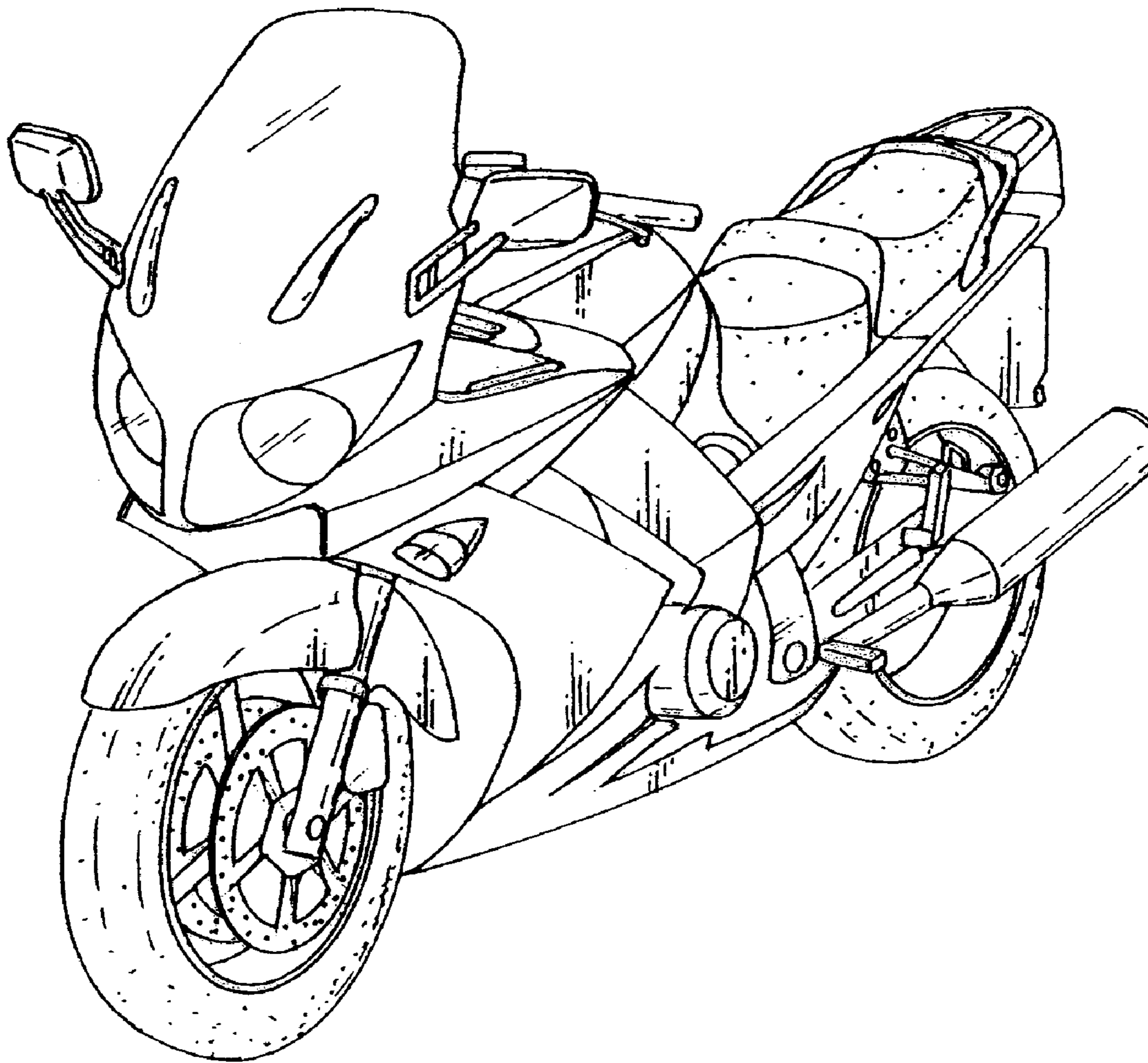

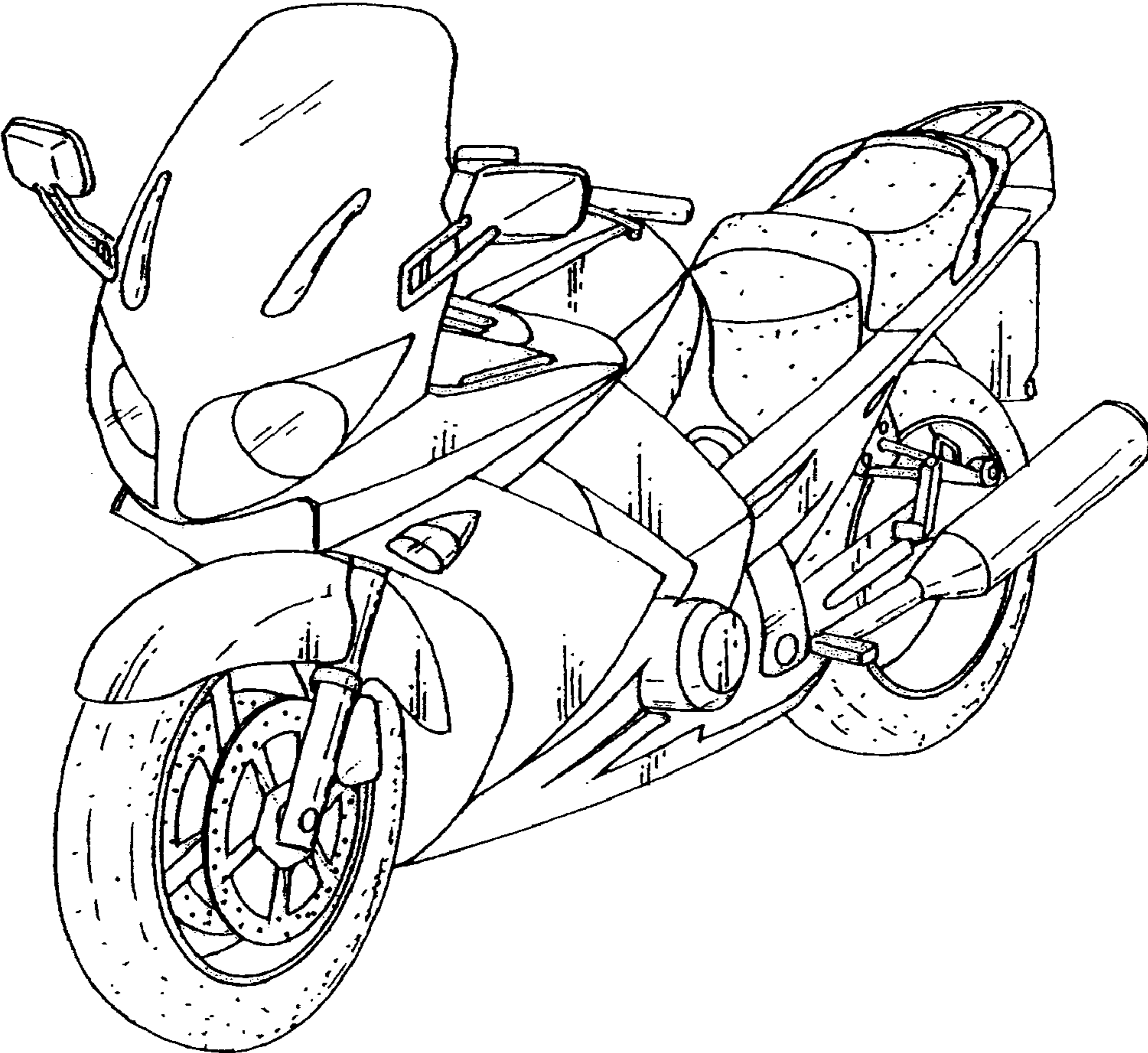

Fig. 1

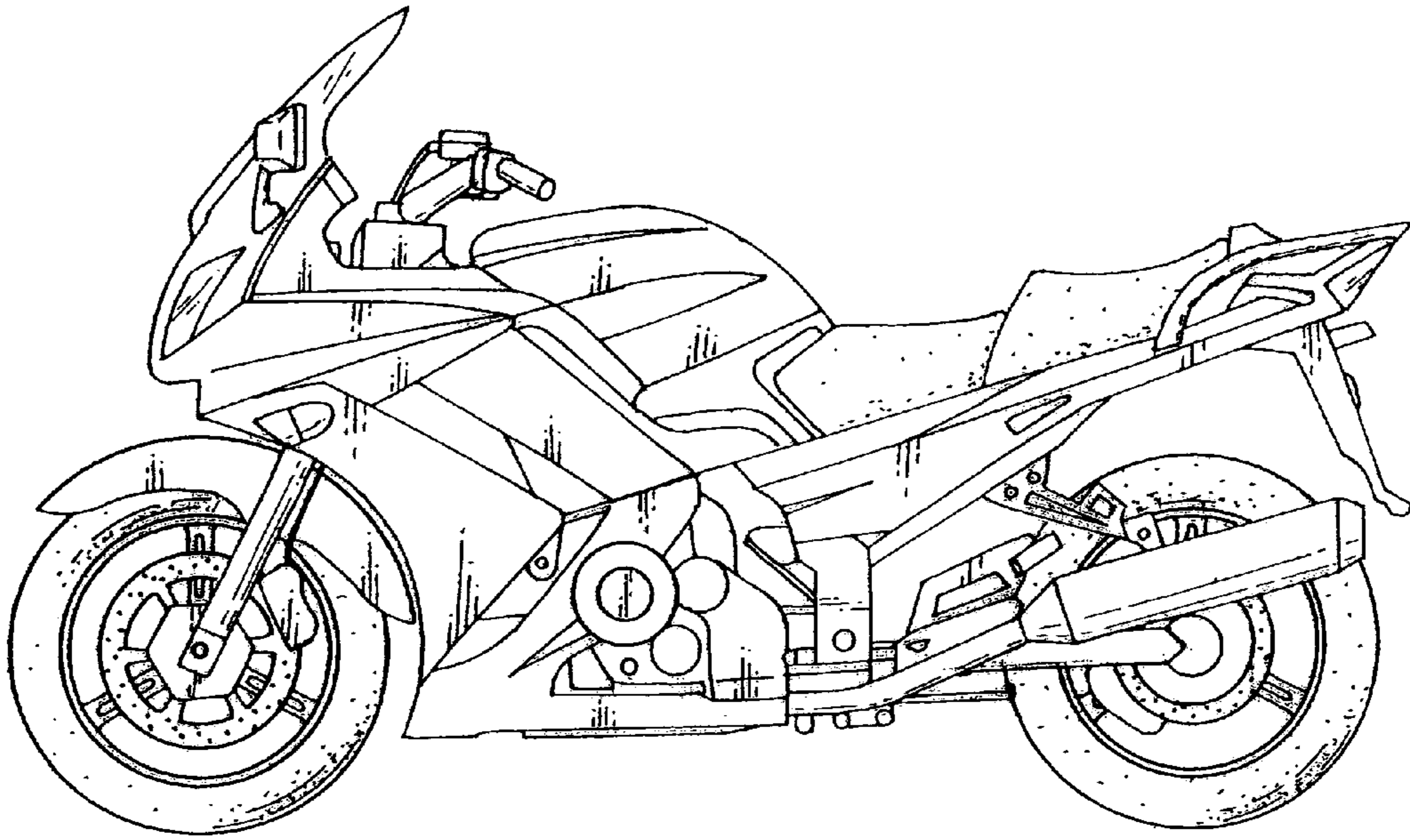

Fig. 2

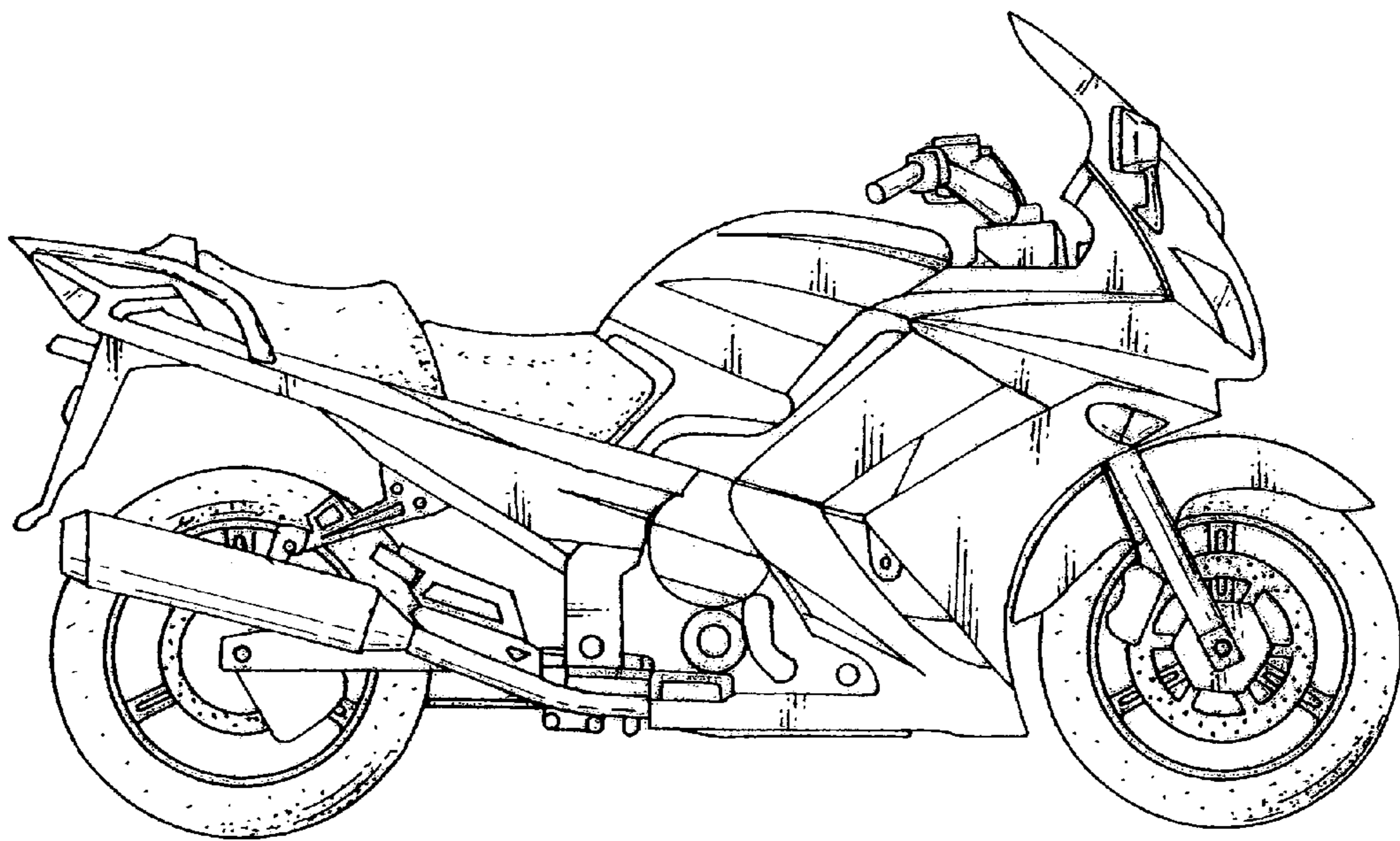

Fig. 3

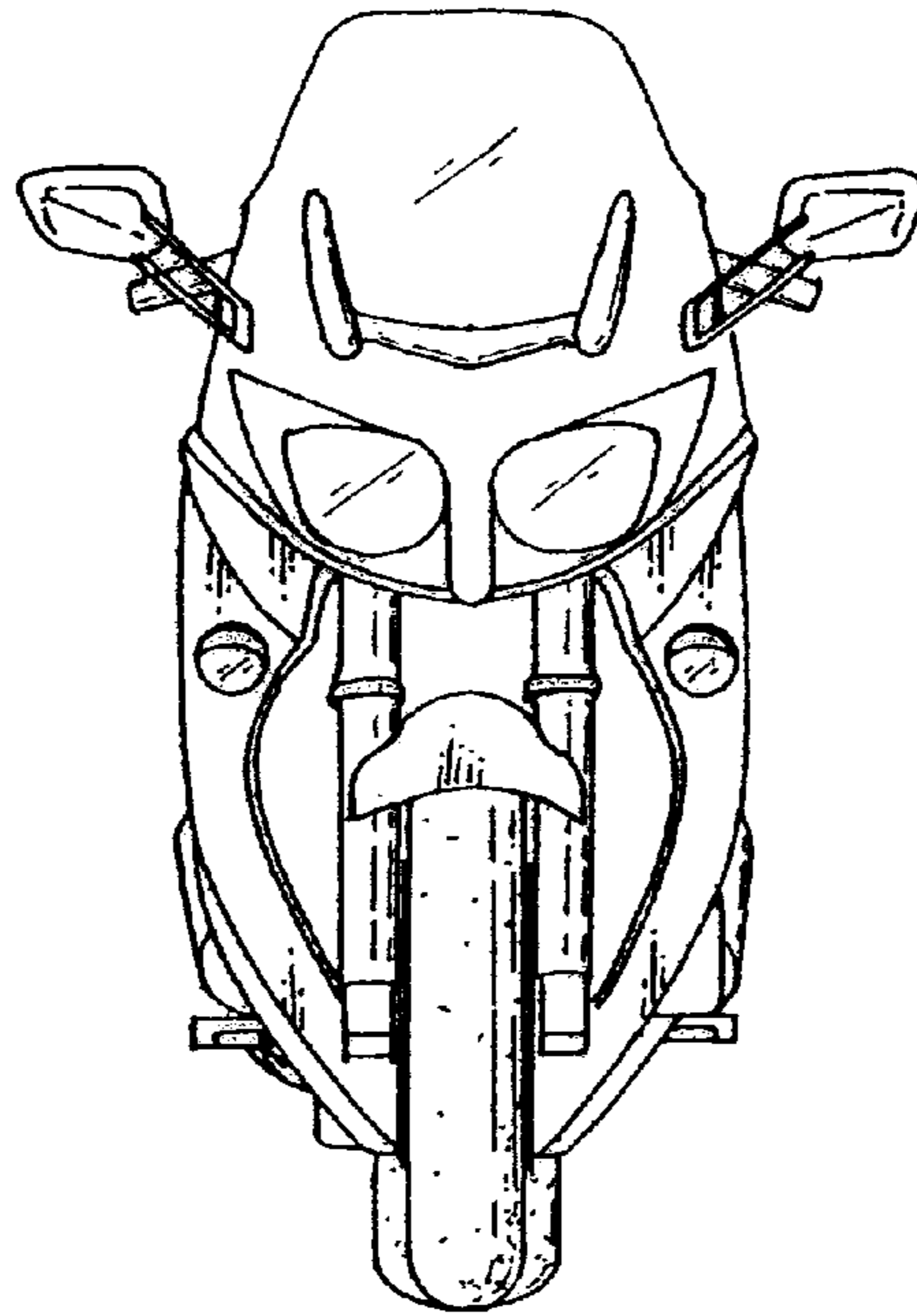

Fig. 4

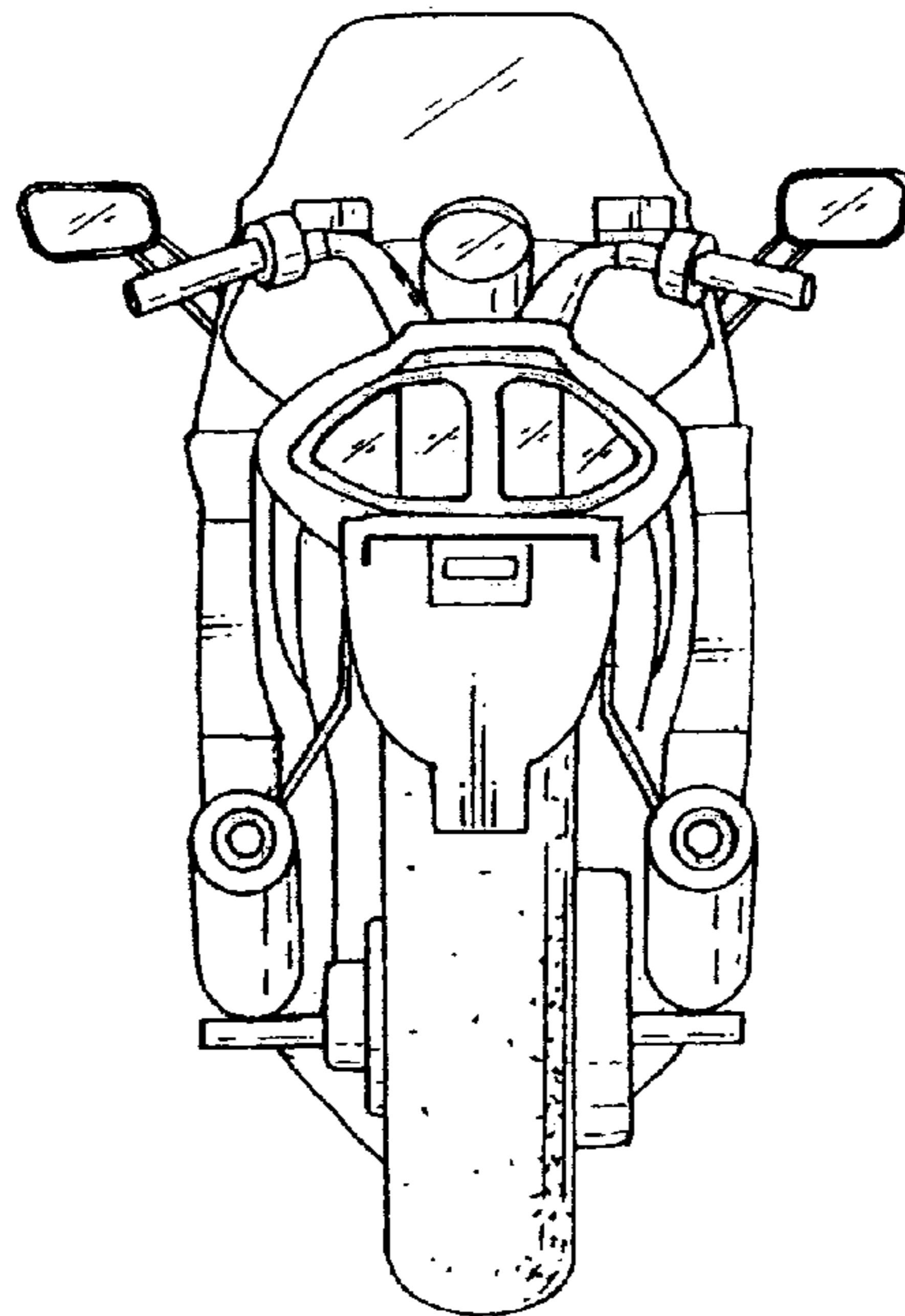

Fig. 5

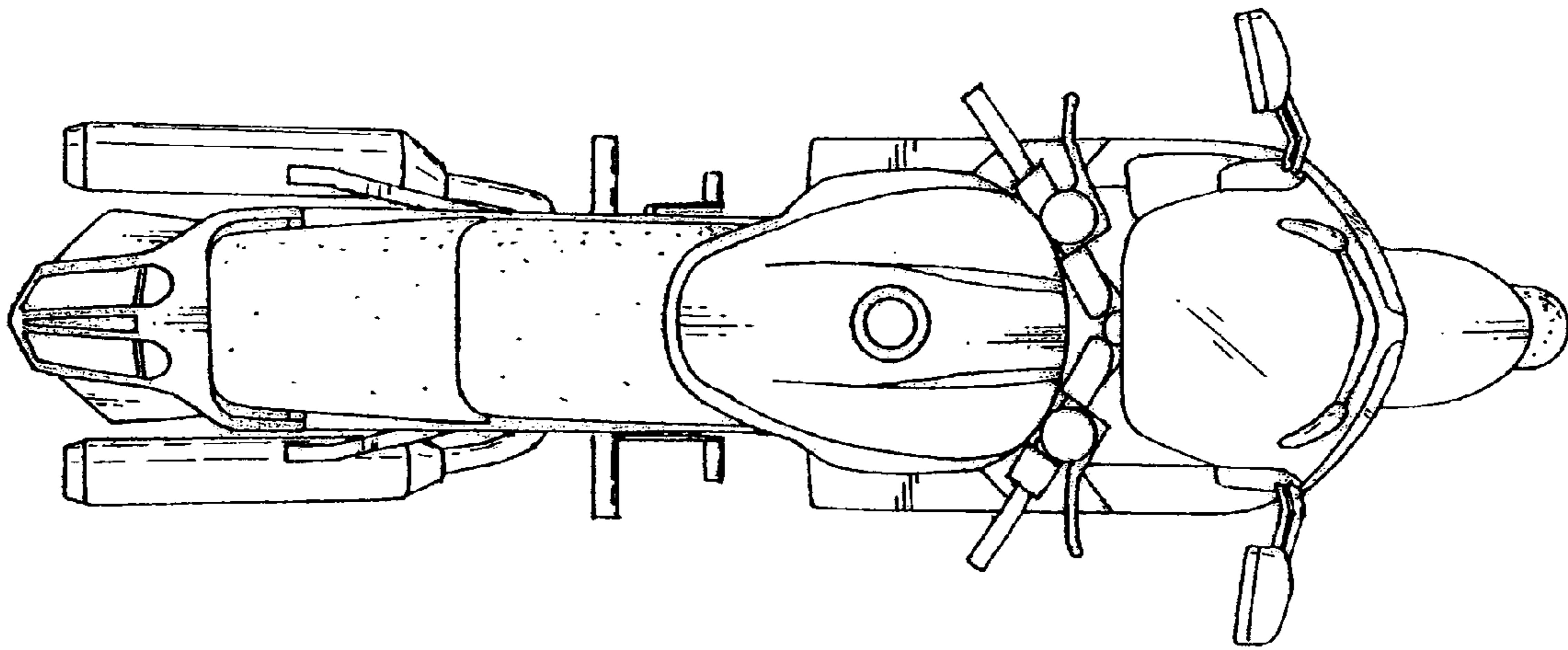

Fig. 6

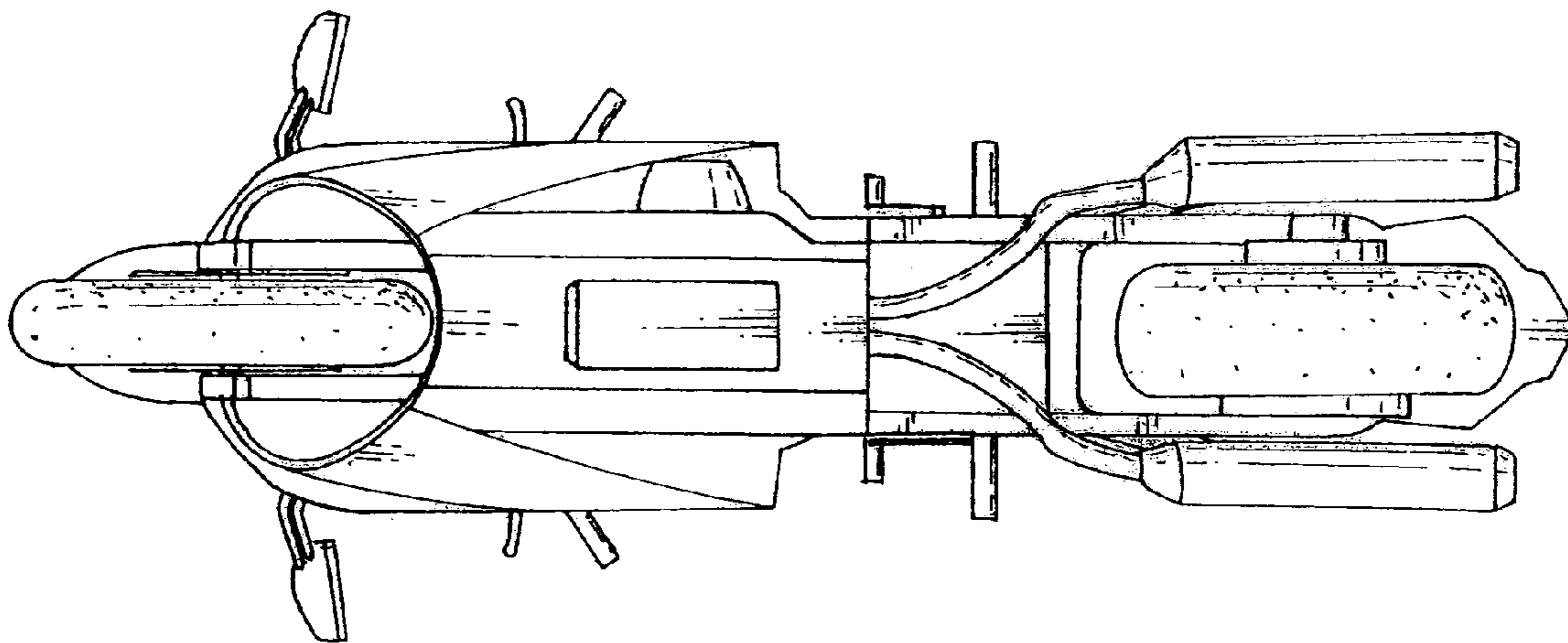

Fig. 7