



US00D531440S

(12) **United States Design Patent** (10) **Patent No.:** **US D531,440 S**
Lo (45) **Date of Patent:** **** Nov. 7, 2006**

(54) **AUTOMATIC FLUID DISPENSER**
(75) Inventor: **Raymond Lo**, Wan Chai (HK)
(73) Assignee: **Touch Free Applications, LLC**,
Moorestown, NJ (US)
(**) Term: **14 Years**
(21) Appl. No.: **29/207,645**
(22) Filed: **Jun. 16, 2004**
(51) **LOC (8) Cl.** **23-02**
(52) **U.S. Cl.** **D6/542**
(58) **Field of Classification Search** D6/542-545;
221/282; 222/14, 173, 146.3, 628, 251, 181.1,
222/181.3; D9/682, 688, 690, 691, 448, 449
See application file for complete search history.

(56) **References Cited**
U.S. PATENT DOCUMENTS
D106,053 S * 9/1937 Maguire D6/542
D332,739 S * 1/1993 Petschek D9/688
D375,643 S * 11/1996 Copeland et al. D6/542
D396,590 S * 8/1998 Warshawsky D6/542
D416,154 S * 11/1999 Diehl D6/542

D426,093 S * 6/2000 Cayouette D6/542
D438,041 S * 2/2001 Huang D6/542
D486,335 S * 2/2004 Sonneman D6/542

* cited by examiner
Primary Examiner—Brian N Vinson
(74) *Attorney, Agent, or Firm*—Howard C. Miskin, Esq.;
Gloria Tsui-Yip, Esq.

(57) **CLAIM**
The design for an automatic fluid dispenser, as shown and described.

DESCRIPTION
FIG. 1 is a perspective view of my new design;
FIG. 2 is a front elevational view;
FIG. 3 is a rear elevational view;
FIG. 4 is a left side view;
FIG. 5 is a right side view;
FIG. 6 is a top view; and,
FIG. 7 is a bottom view.
The broken lines showing of a sensor, battery compartment, screw, and rotating dial in FIGS. 1-7 are for illustrative purposes only and form no part of the claimed design.

1 Claim, 4 Drawing Sheets

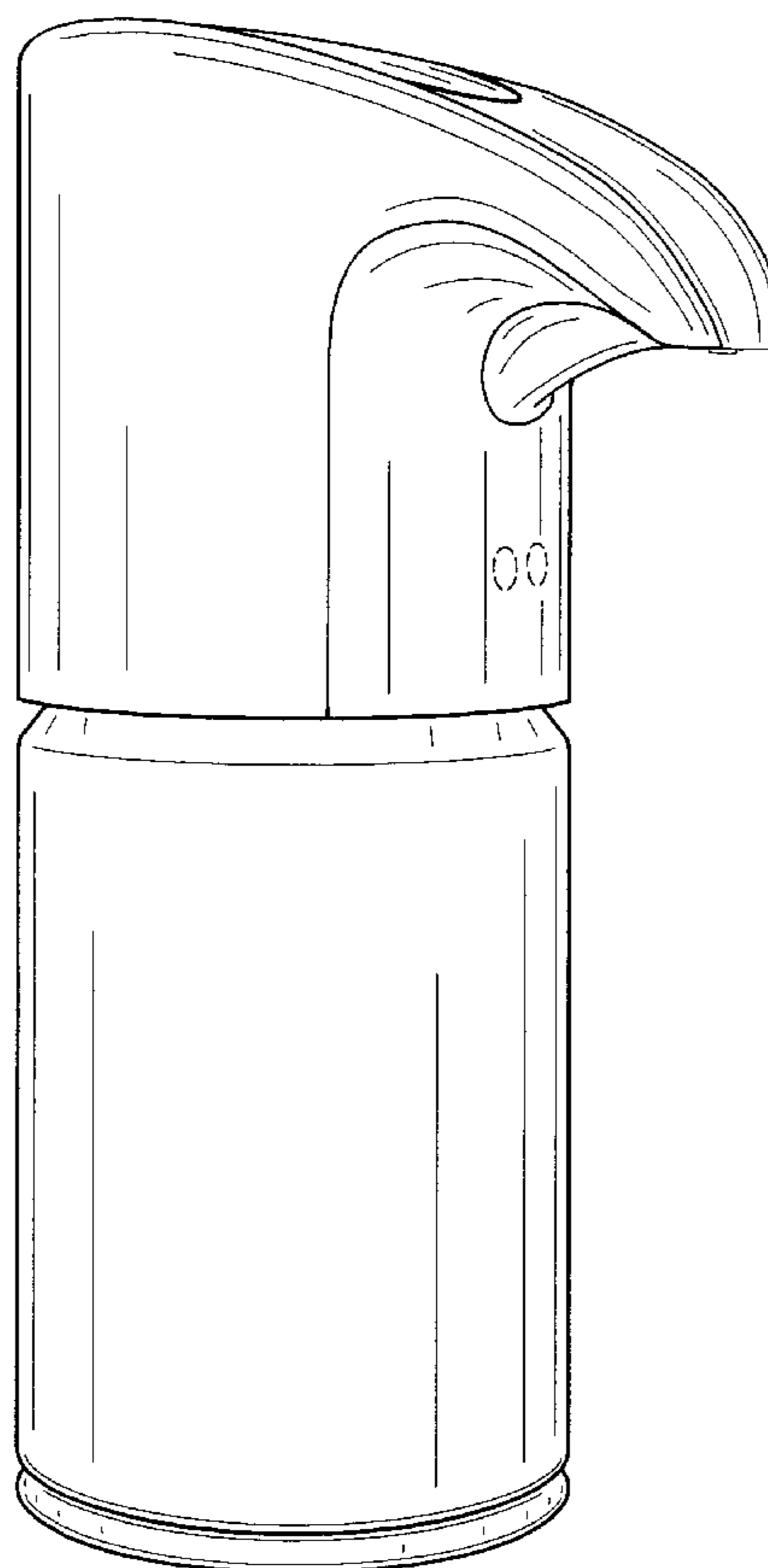

FIG. 1

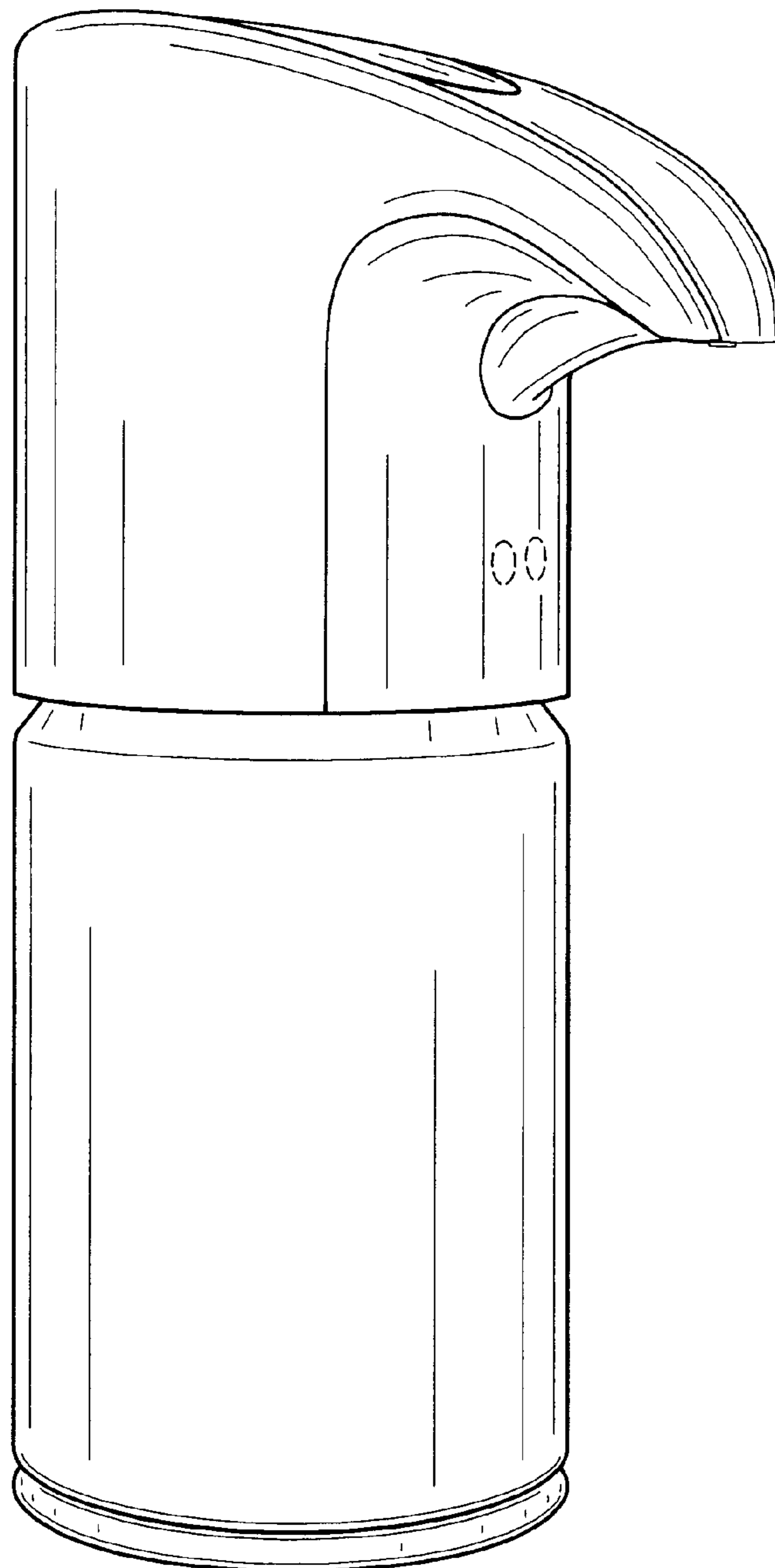

FIG. 2

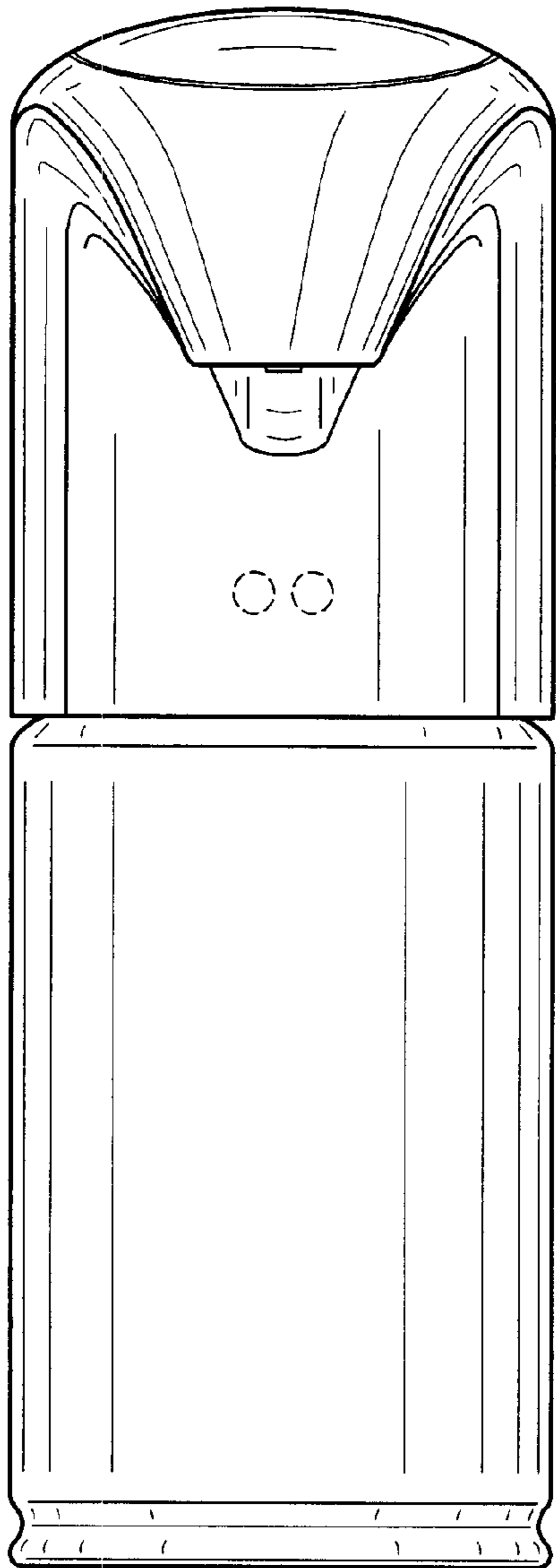

FIG. 3

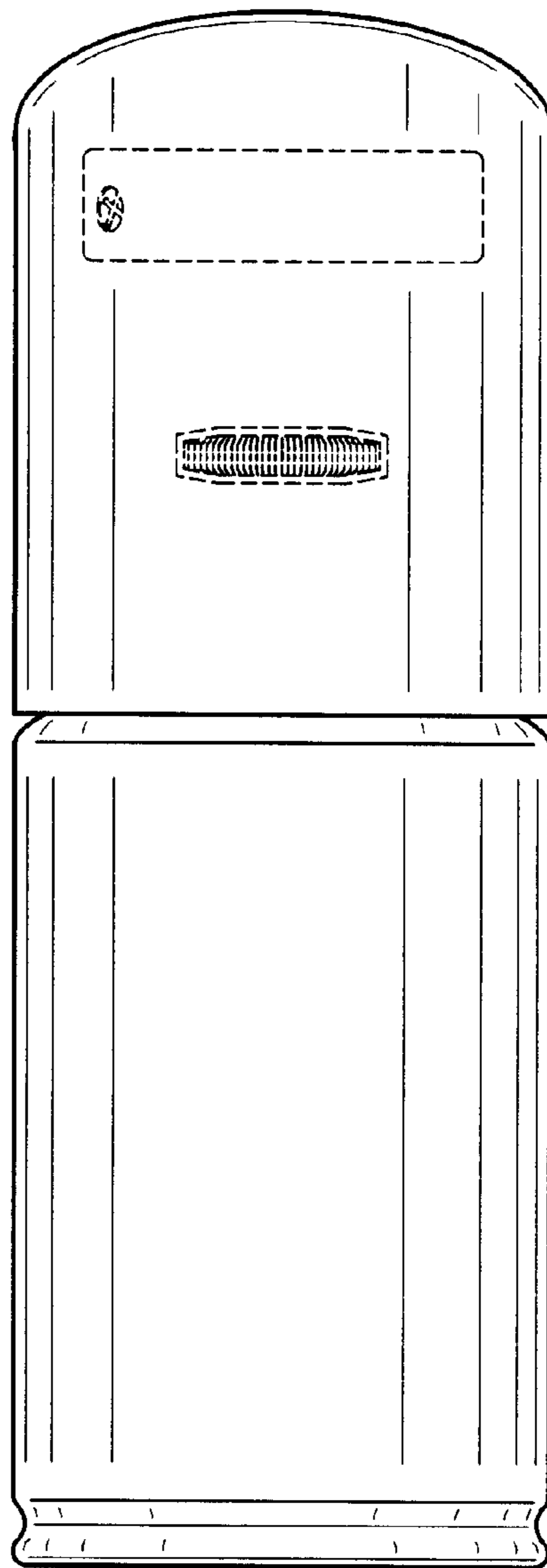

FIG. 4

FIG. 5

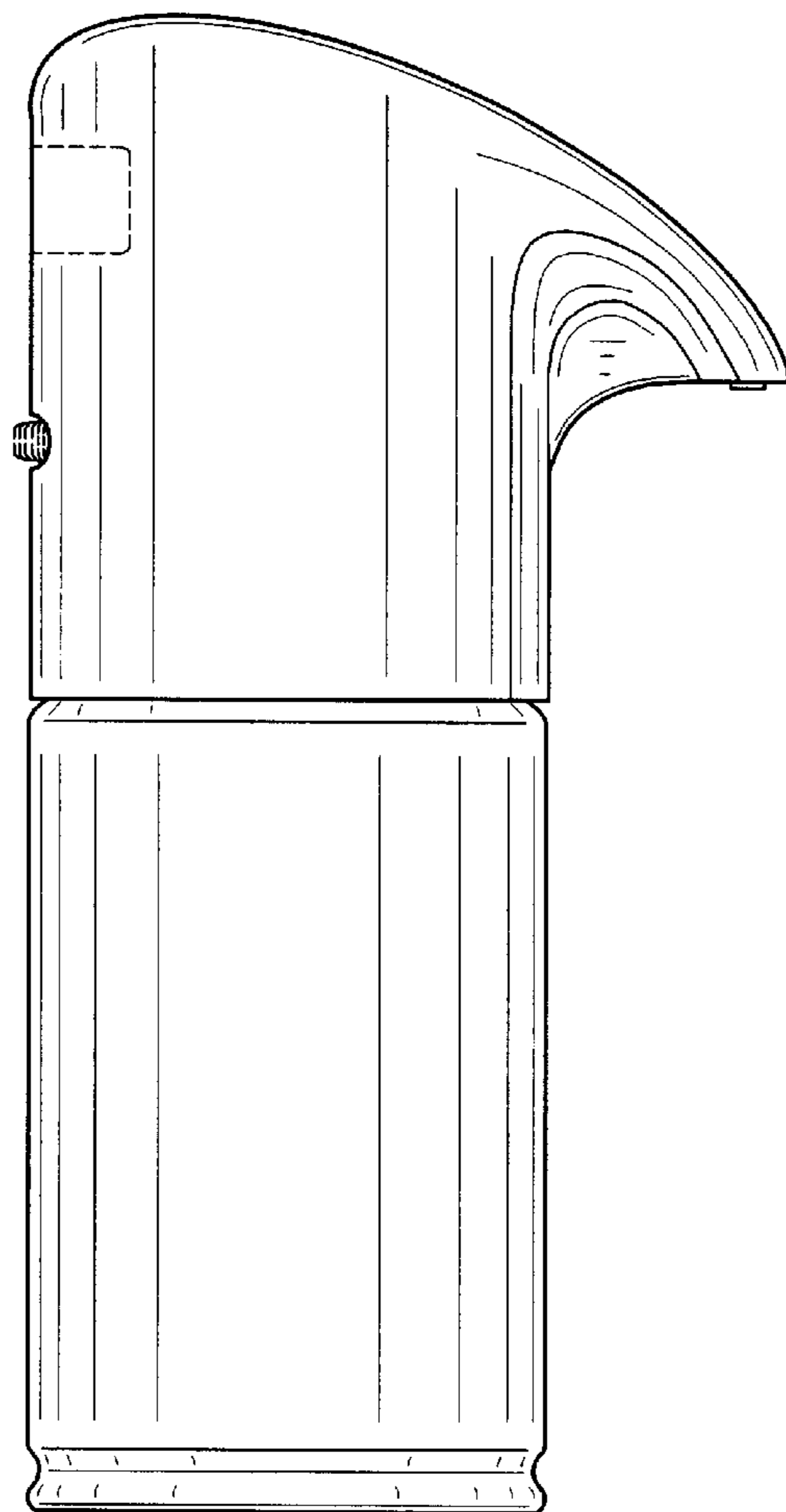
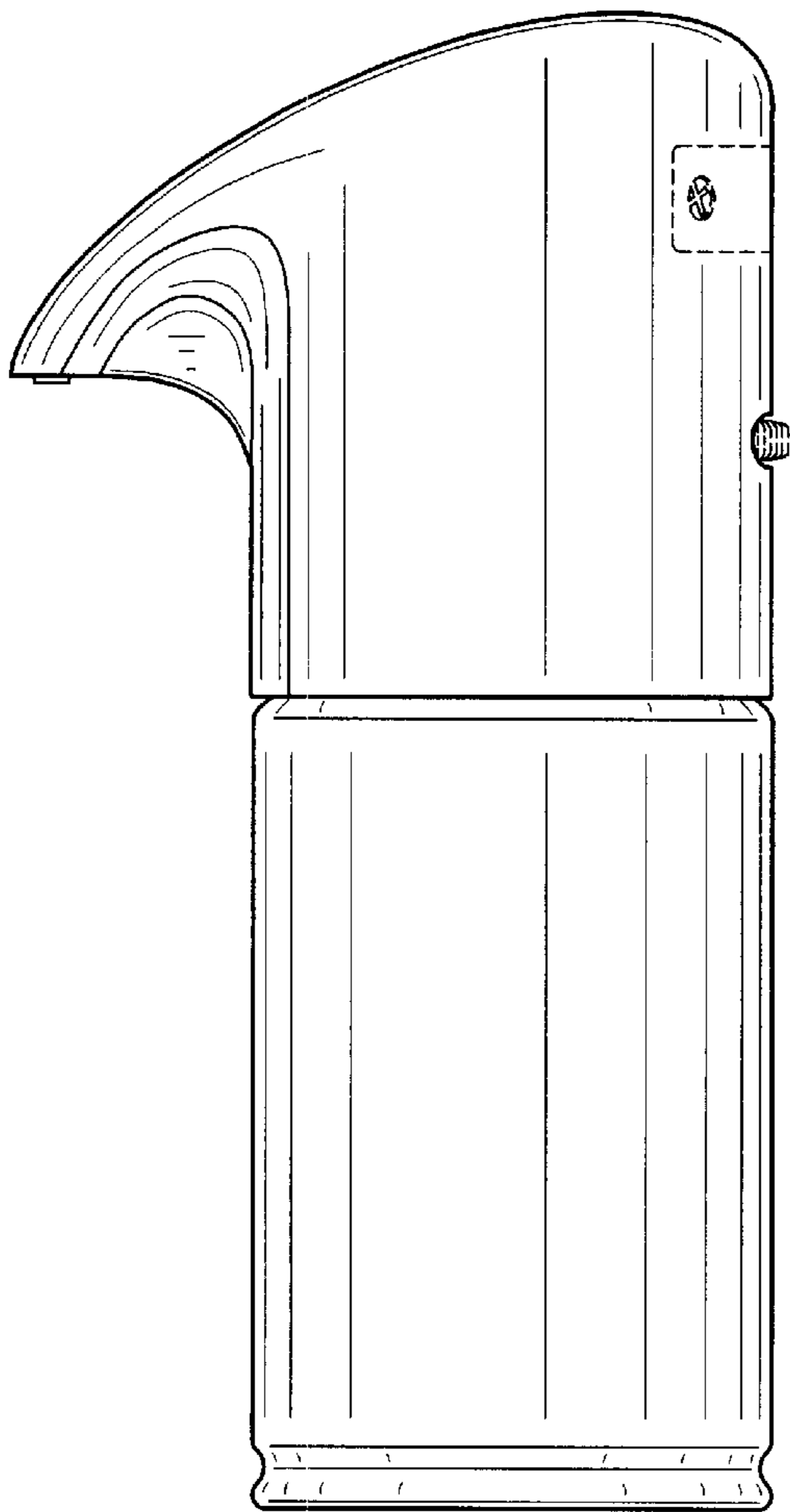

FIG. 6

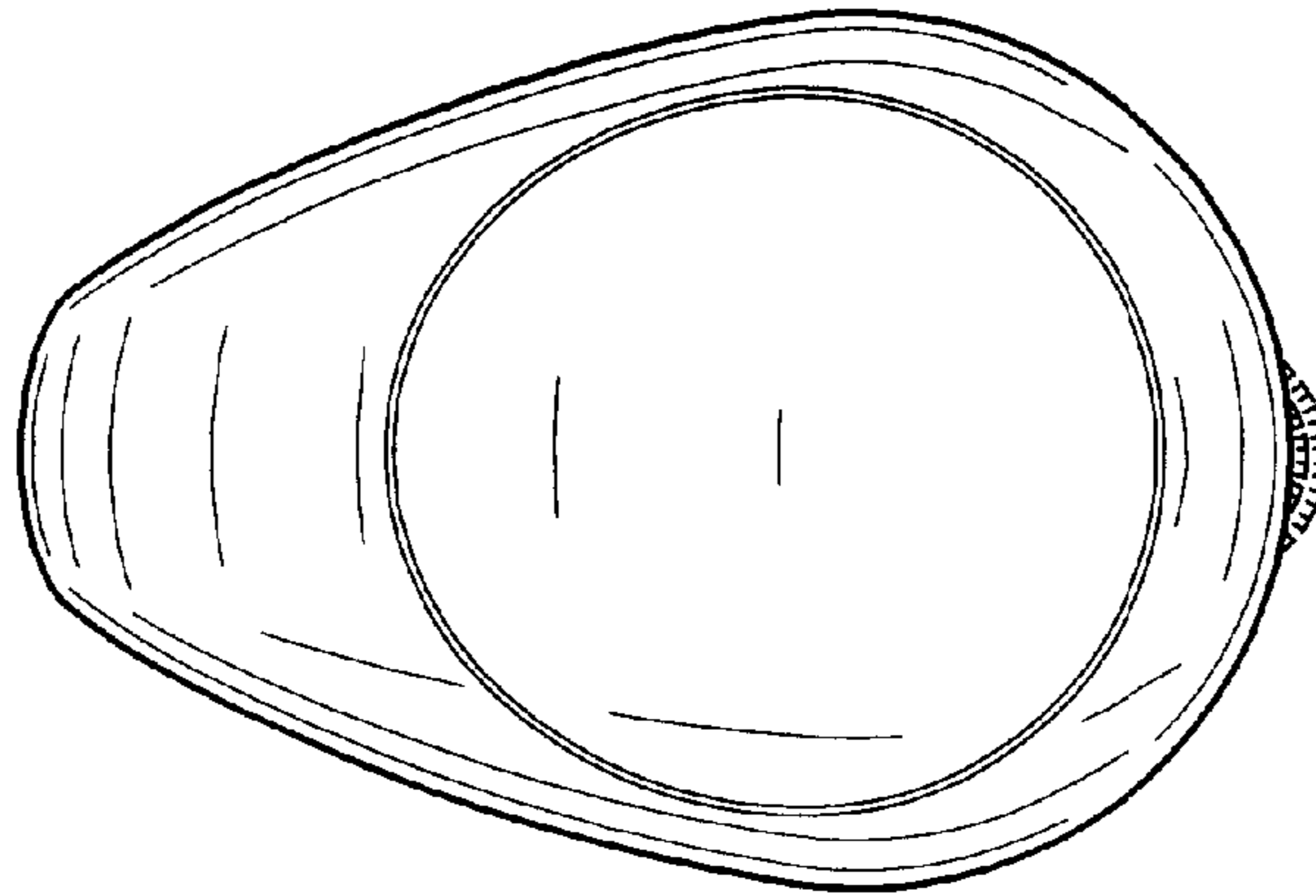

FIG. 7

