



US00D531378S

(12) **United States Design Patent**  
**Angel et al.**

(10) **Patent No.:** **US D531,378 S**  
(45) **Date of Patent:** **\*\* Oct. 31, 2006**

(54) **STABILIZER JACK PAD**

(75) Inventors: **Bruce A. Angel**, Kernersville, NC (US);  
**Anthony D. Moore**, Summerfield, NC  
(US); **Jeffrey R. Russell**, Winston  
Salem, NC (US); **David P. Tickle**,  
Summerfield, NC (US)

(73) Assignee: **Camco Manufacturing, Inc.**,  
Greensboro, NC (US)

(\*\*) Term: **14 Years**

(21) Appl. No.: **29/222,281**

(22) Filed: **Jan. 27, 2005**

(51) **LOC (8) Cl.** ..... **12-05**

(52) **U.S. Cl.** ..... **D34/31; D34/38**

(58) **Field of Classification Search** ..... D34/31,  
D34/32; D9/456, 455; 108/51.3, 52.1, 53.1,  
108/53.3, 53.5, 55.1, 57.3; 254/88, 94, DIG. 1;  
248/346.02

See application file for complete search history.

(56) **References Cited**

**U.S. PATENT DOCUMENTS**

D9,254 S	*	5/1876	Cooper	.....	D12/203
4,474,387 A	*	10/1984	Maranell et al.	.....	280/293
D357,650 S	*	4/1995	Evans et al.	.....	D12/106
5,458,315 A	*	10/1995	Blatz et al.	.....	254/88
D426,933 S	*	6/2000	Redfern	.....	D34/38
6,101,955 A	*	8/2000	Salce	.....	108/51.11
D434,509 S	*	11/2000	Oliver et al.	.....	D25/199
D440,022 S	*	4/2001	Simpson et al.	.....	D34/31
6,769,367 B1	*	8/2004	Schutz	.....	108/51.11

6,910,668 B1	*	6/2005	Henning	.....	248/346.02
D508,300 S	*	8/2005	O'Dell et al.	.....	D34/38
D519,838 S	*	5/2006	Brooks	.....	D9/456

**OTHER PUBLICATIONS**

Super RV Jack Pad, Stag 2004 RV Parts & Accessories catalog, p. 483, Atlanta, GA.

Stabilizing Base Pad, Stag 2004 RV Parts & Accessories catalog, p. 483, Atlanta, GA.

Lynx Levelers Leveling Blocks, Stag RV Parts & Accessories catalog, pp. 484 & 485, Atlanta, GA.

\* cited by examiner

*Primary Examiner*—Cynthia E. Ramirez

(57) **CLAIM**

The ornamental design for a stabilizer jack pad, as shown and described.

**DESCRIPTION**

FIG. 1 is a bottom plan view of the stabilizer jack pad embodying our design;

FIG. 2 is a rear elevational view of our design; the front elevational view being a mirror image thereof;

FIG. 3 is a cross-sectional view of our design as seen along lines 3—3 of FIG. 1;

FIG. 4 is a left side elevational view of our design;

FIG. 5 is a top plan view of our design;

FIG. 6 is a right side elevational view of our design;

FIG. 7 is a bottom, front, right side perspective view of our design; and,

FIG. 8 is a top, rear, left side perspective view of our design.

**1 Claim, 3 Drawing Sheets**

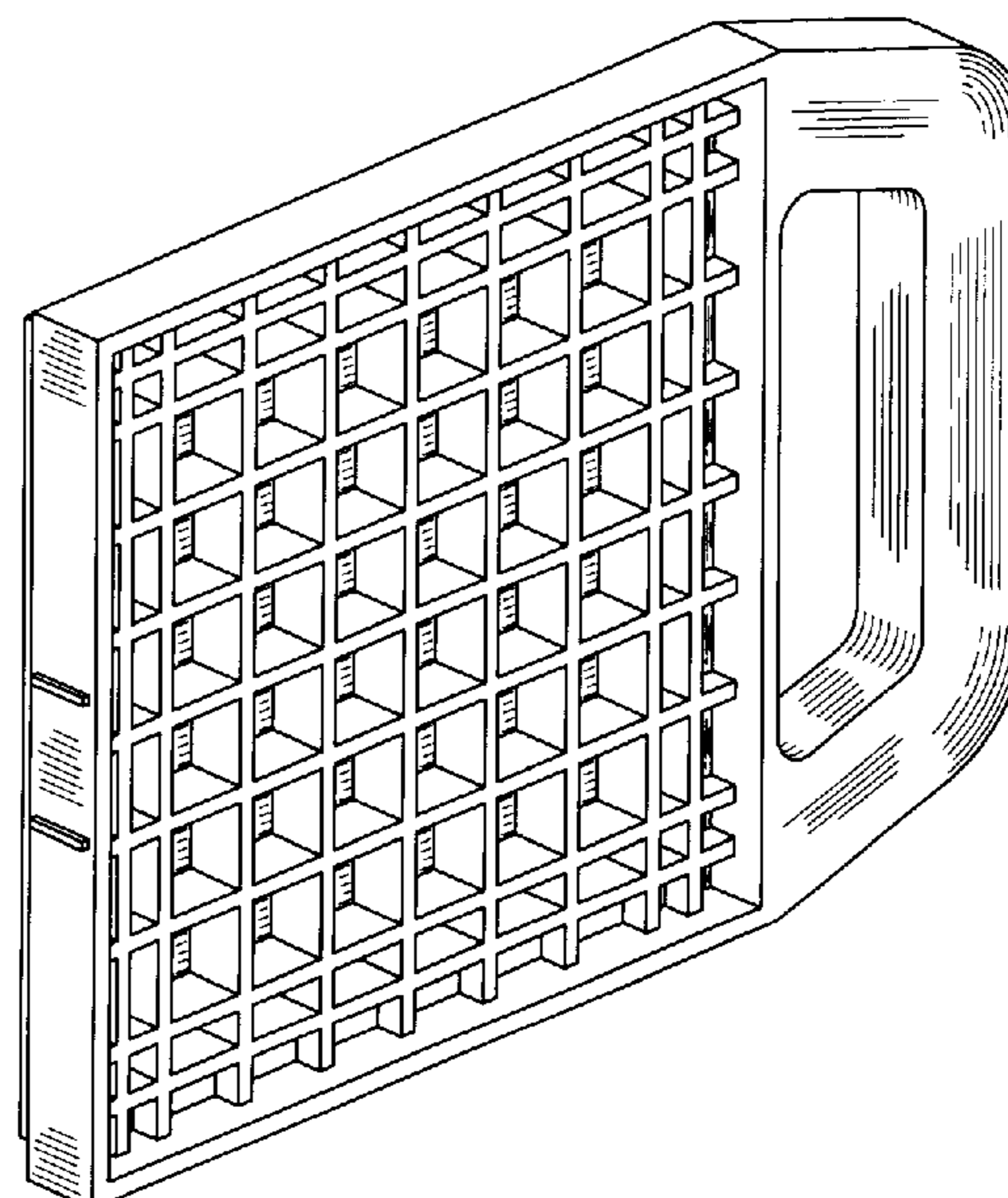
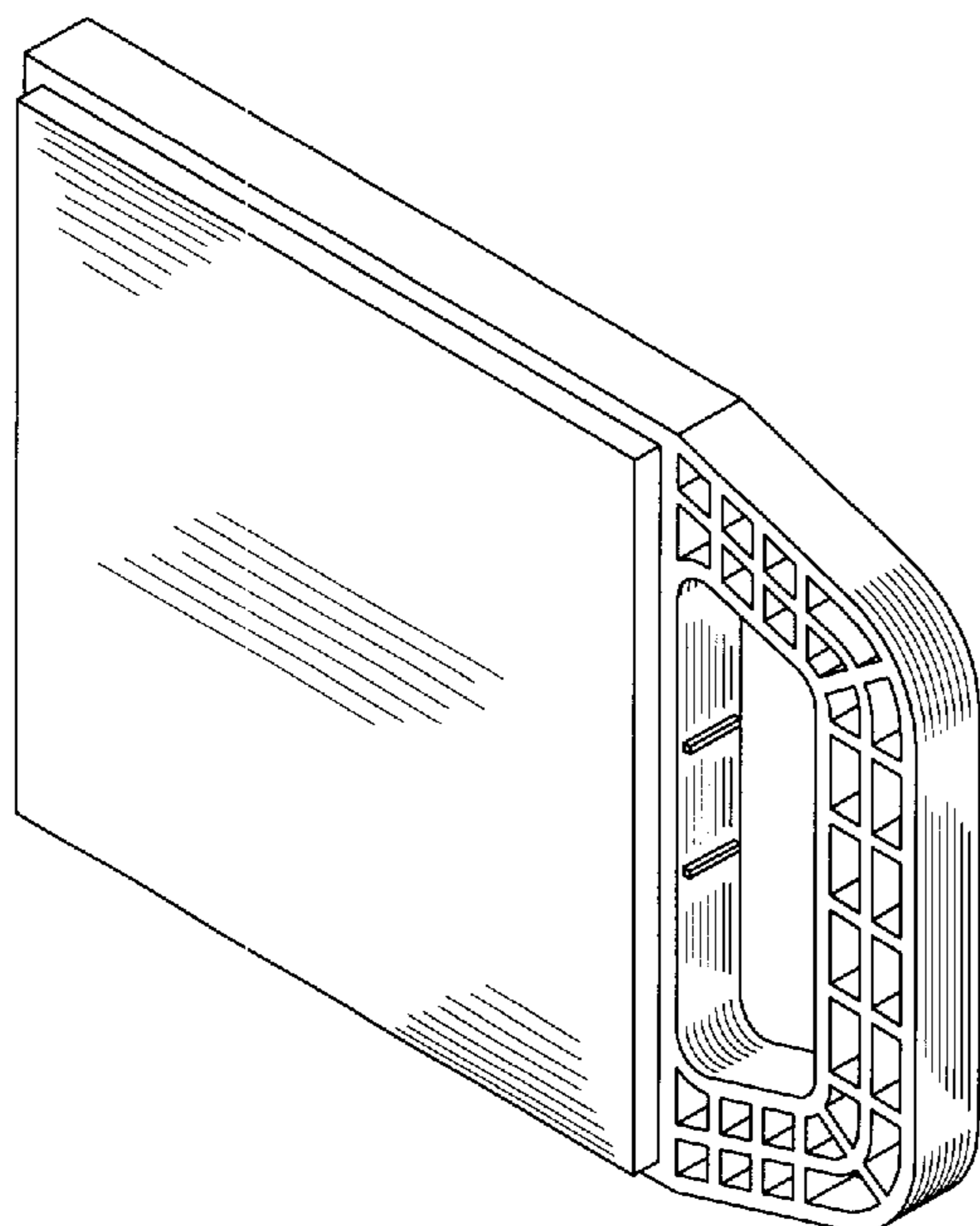

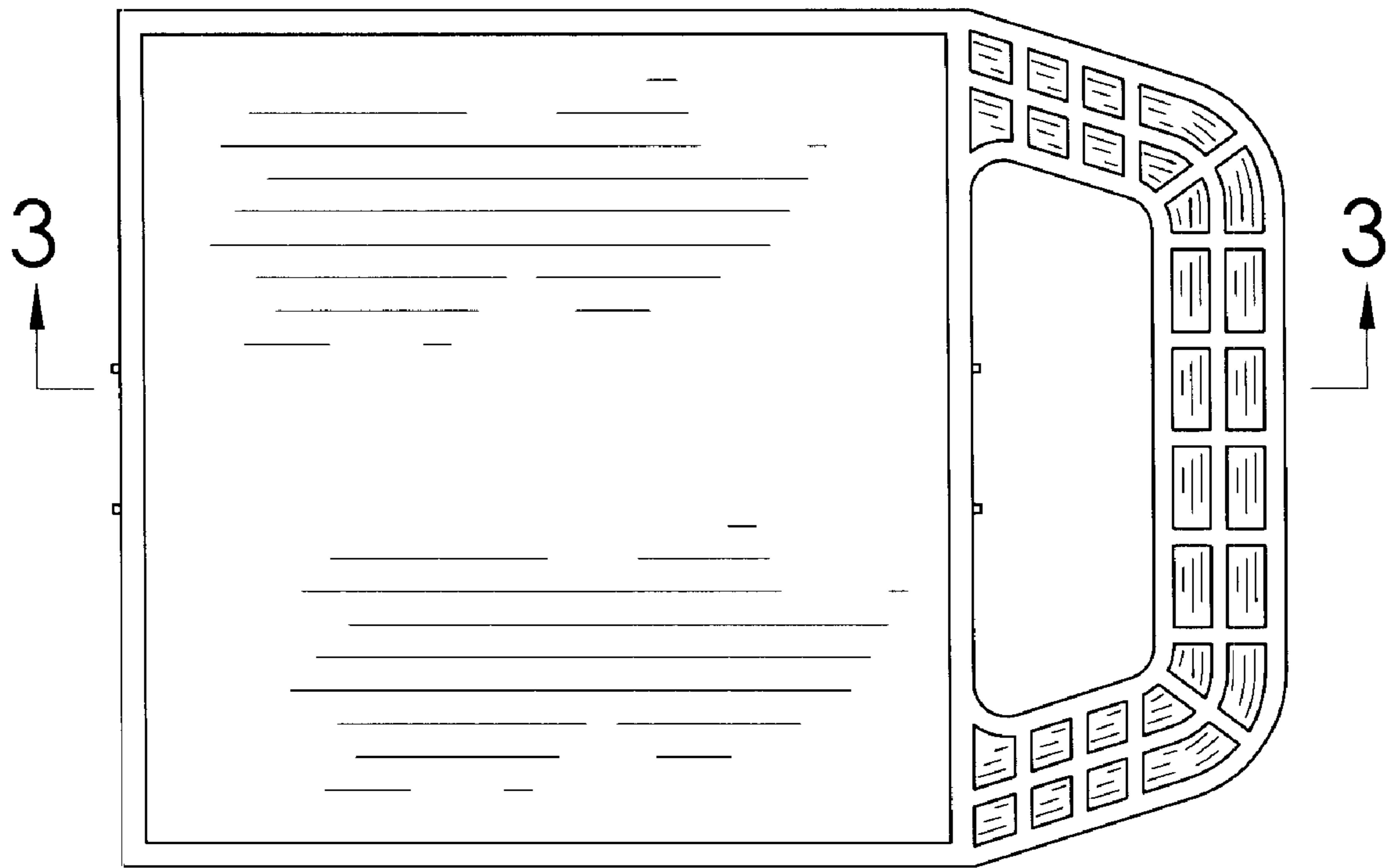

FIG. 1

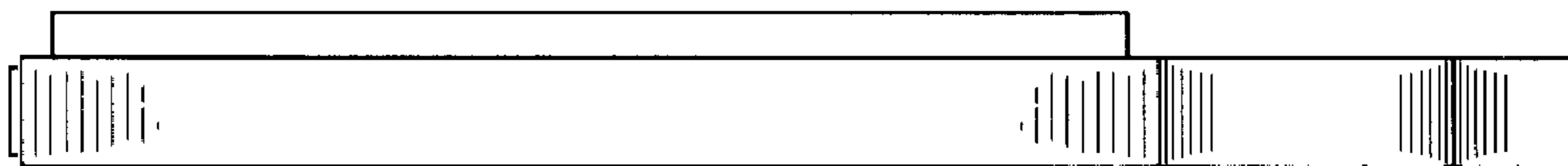

FIG. 2

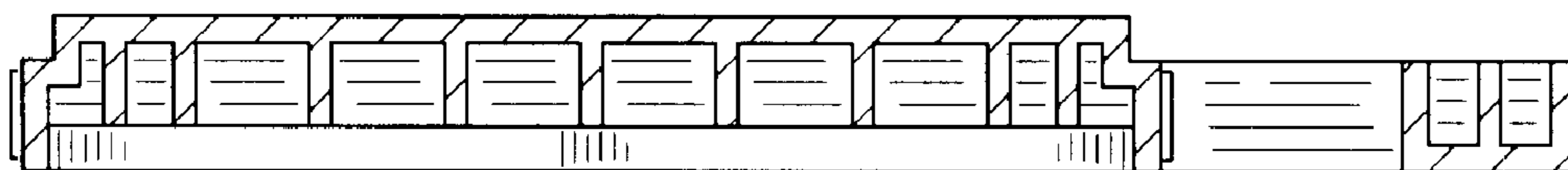

FIG. 3

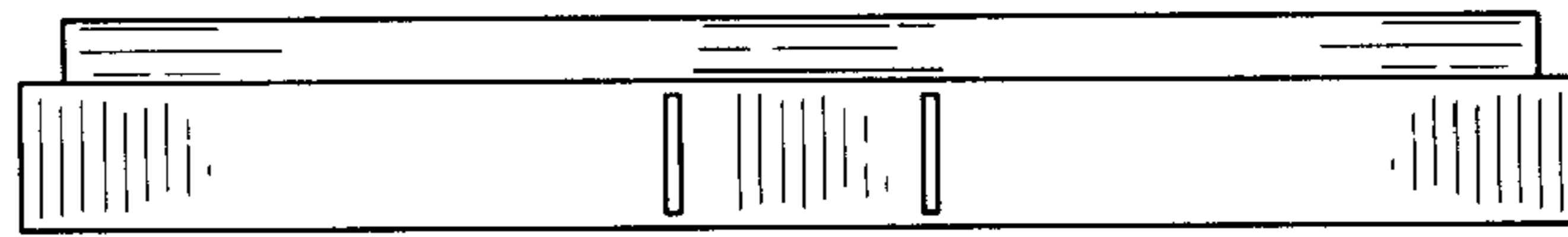

FIG. 4

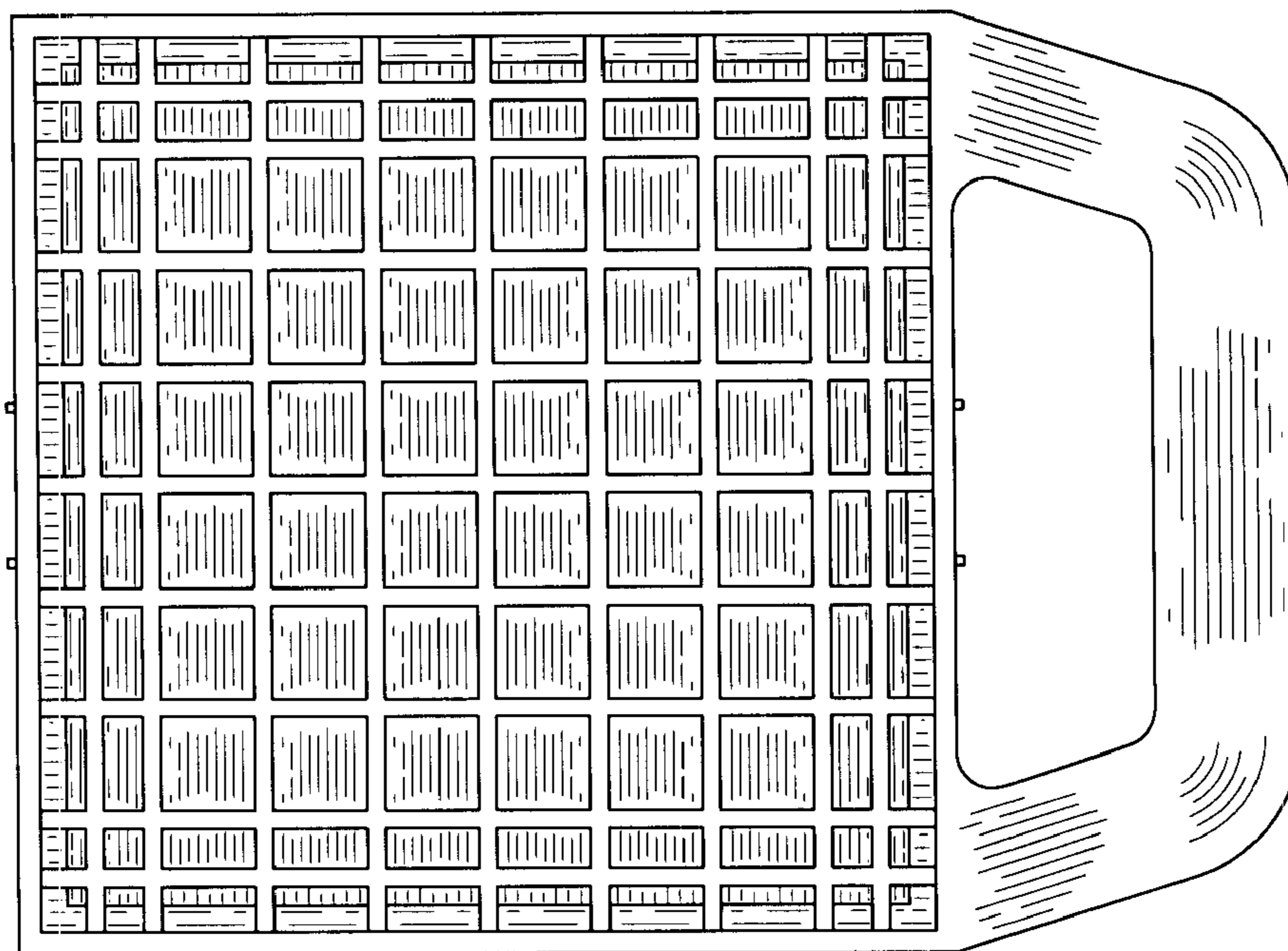

FIG. 5

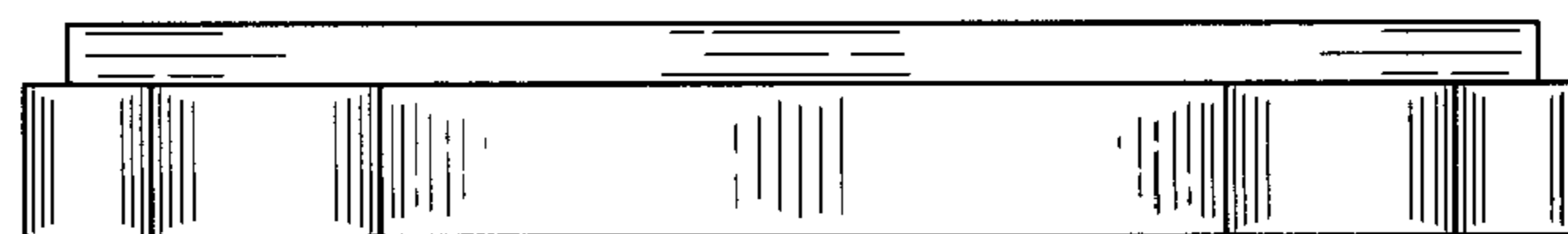

FIG. 6

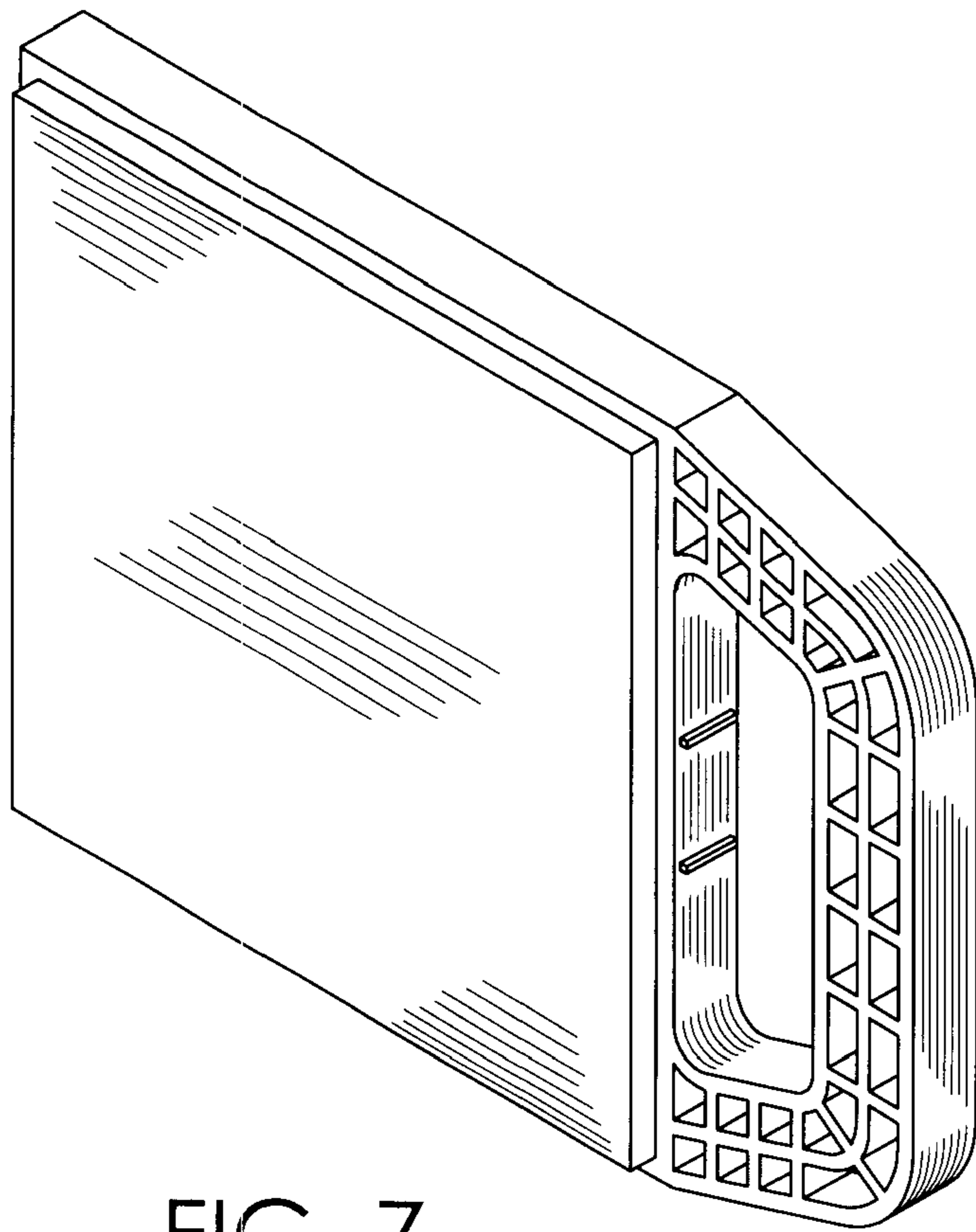

FIG. 7

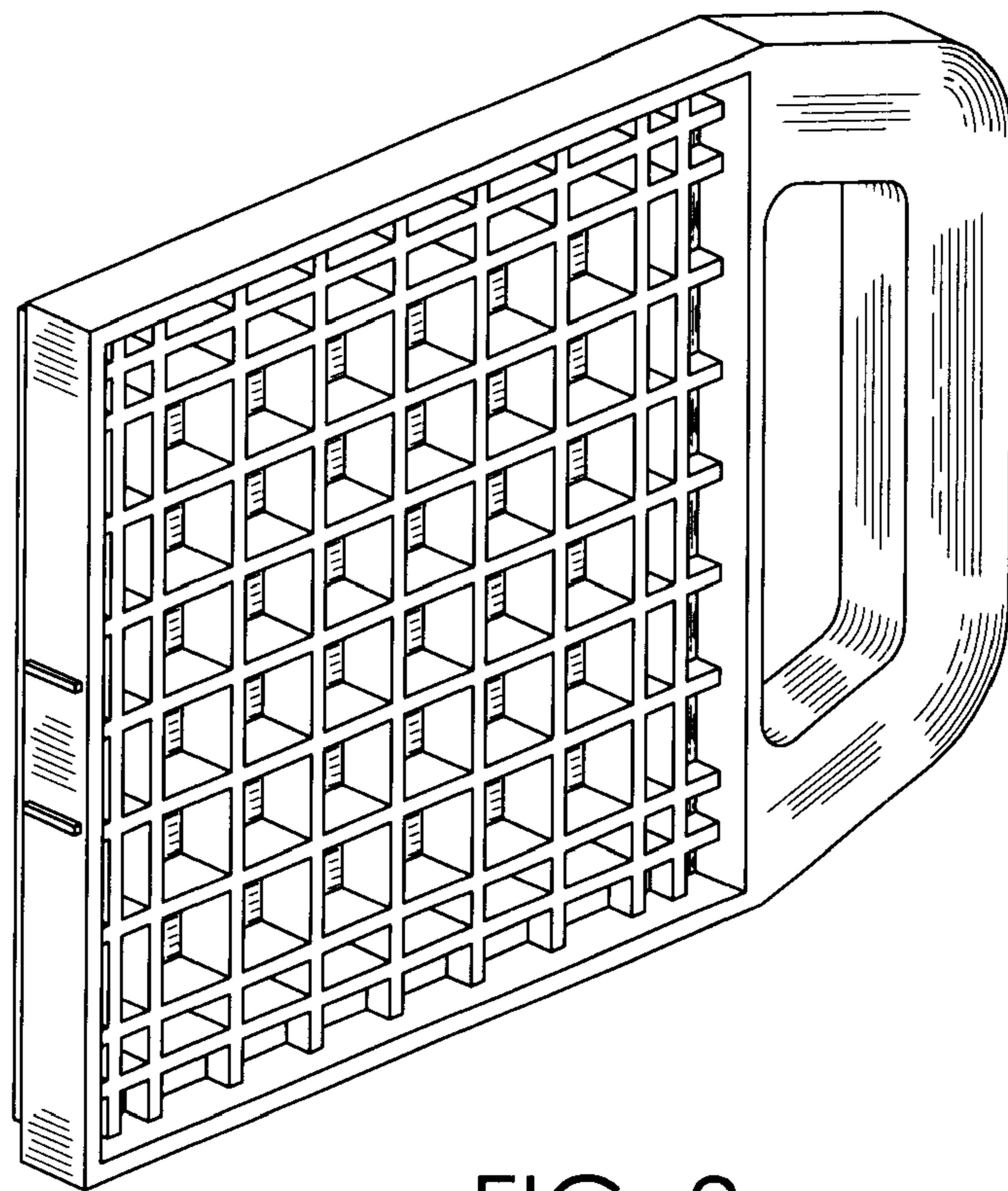

FIG. 8