



US00D531107S

(12) **United States Design Patent** (10) **Patent No.:** **US D531,107 S**  
**Frers** (45) **Date of Patent:** **\*\* Oct. 31, 2006**

(54) **BOAT**  
(75) Inventor: **German Frers, Milan (IT)**  
(73) Assignee: **Frers S.R.L., Milan (IT)**  
(\*\*) Term: **14 Years**  
(21) Appl. No.: **29/216,093**  
(22) Filed: **Oct. 29, 2004**  
(51) **LOC (8) Cl.** ..... **12-06**  
(52) **U.S. Cl.** ..... **D12/303**  
(58) **Field of Classification Search** ..... D12/300,  
D12/303, 304, 315, 318; 114/39.11, 39.14,  
114/39.15, 39.21, 39.25, 343, 355; D21/544  
See application file for complete search history.

(56) **References Cited**

**U.S. PATENT DOCUMENTS**

D175,724 S	*	10/1955	Lyman	.....	D11/77
D207,138 S	*	3/1967	Andersen	.....	D12/303
D277,272 S	*	1/1985	Sladky et al.	.....	D12/596
4,702,193 A	*	10/1987	Jones et al.	.....	114/354
4,750,446 A	*	6/1988	Sussman	.....	114/345
5,628,265 A	*	5/1997	Azima et al.	.....	114/39.21
D416,851 S	*	11/1999	Mitchell	.....	D12/303

\* cited by examiner

*Primary Examiner*—Holly Baynham  
*Assistant Examiner*—Cynthia M. Chin

(74) *Attorney, Agent, or Firm*—Shoemaker and Mattare, Ltd.

(57) **CLAIM**

The ornamental design for a boat, as shown and described.

**DESCRIPTION**

FIG. 1 is an enlarged partial top, left, rear perspective view of my design for a boat;  
FIG. 2 is an enlarged partial top, left, front perspective view thereof;  
FIG. 3 is a top plan view thereof showing the rear platform in a lowered position;  
FIG. 4 is a reduced right elevational view, the left side being a mirror image thereof;  
FIG. 5 is an enlarged bottom, right, front perspective view of the hull, shown separately for ease of illustration;  
FIG. 6 is an enlarged partial bottom, right, front perspective view of a second embodiment of my design for a boat;  
FIG. 7 is an enlarged partial top, right, front perspective view thereof;  
FIG. 8 is a top plan view thereof showing the rear platform in a lowered position;  
FIG. 9 is a reduced right elevational view, the left side being a mirror image thereof; and,  
FIG. 10 is an enlarged bottom, right, front perspective view of the hull, shown separately for ease of illustration.  
FIGS. 3 and 8 show the boat with the ropes removed for ease of illustration.

**1 Claim, 4 Drawing Sheets**

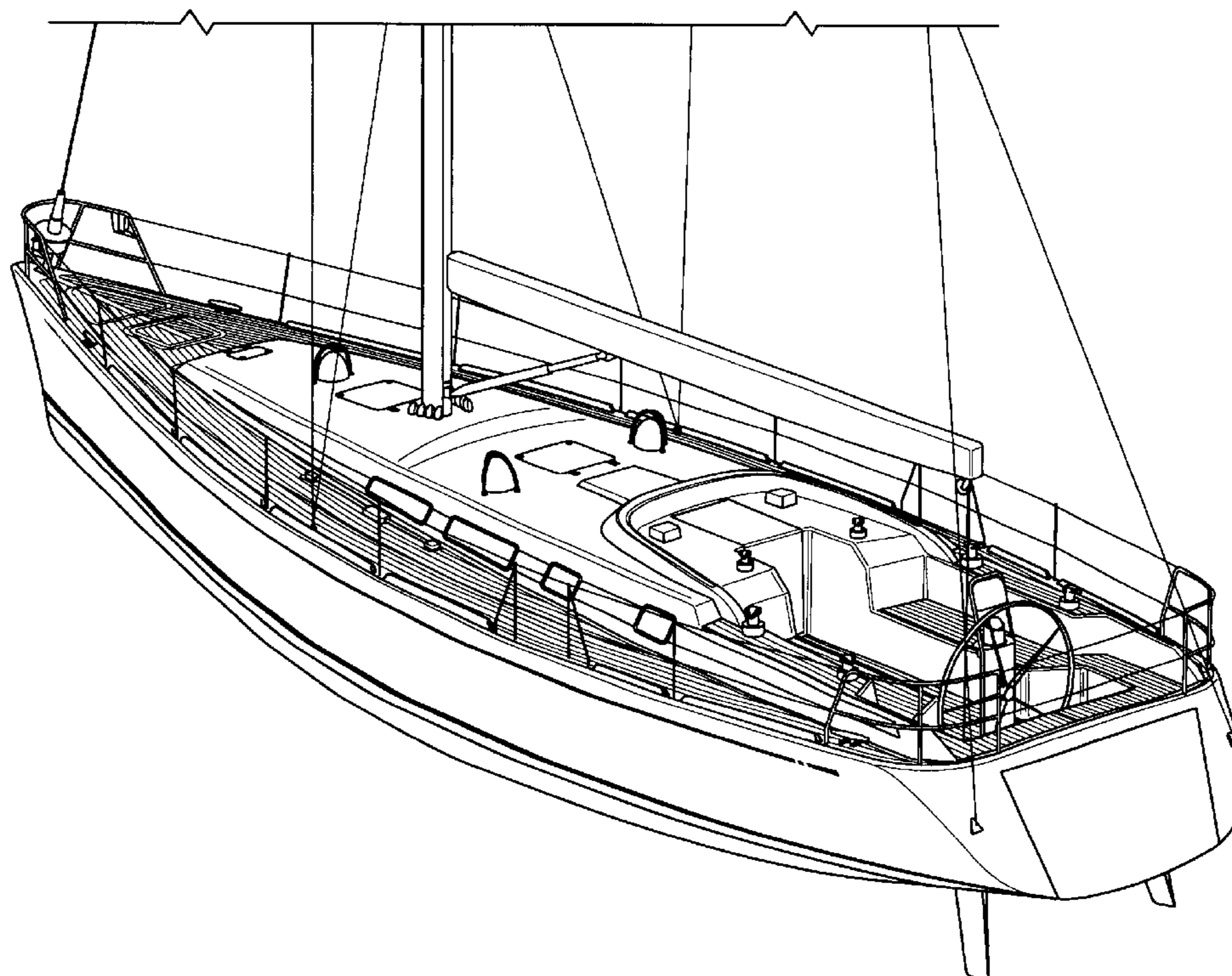

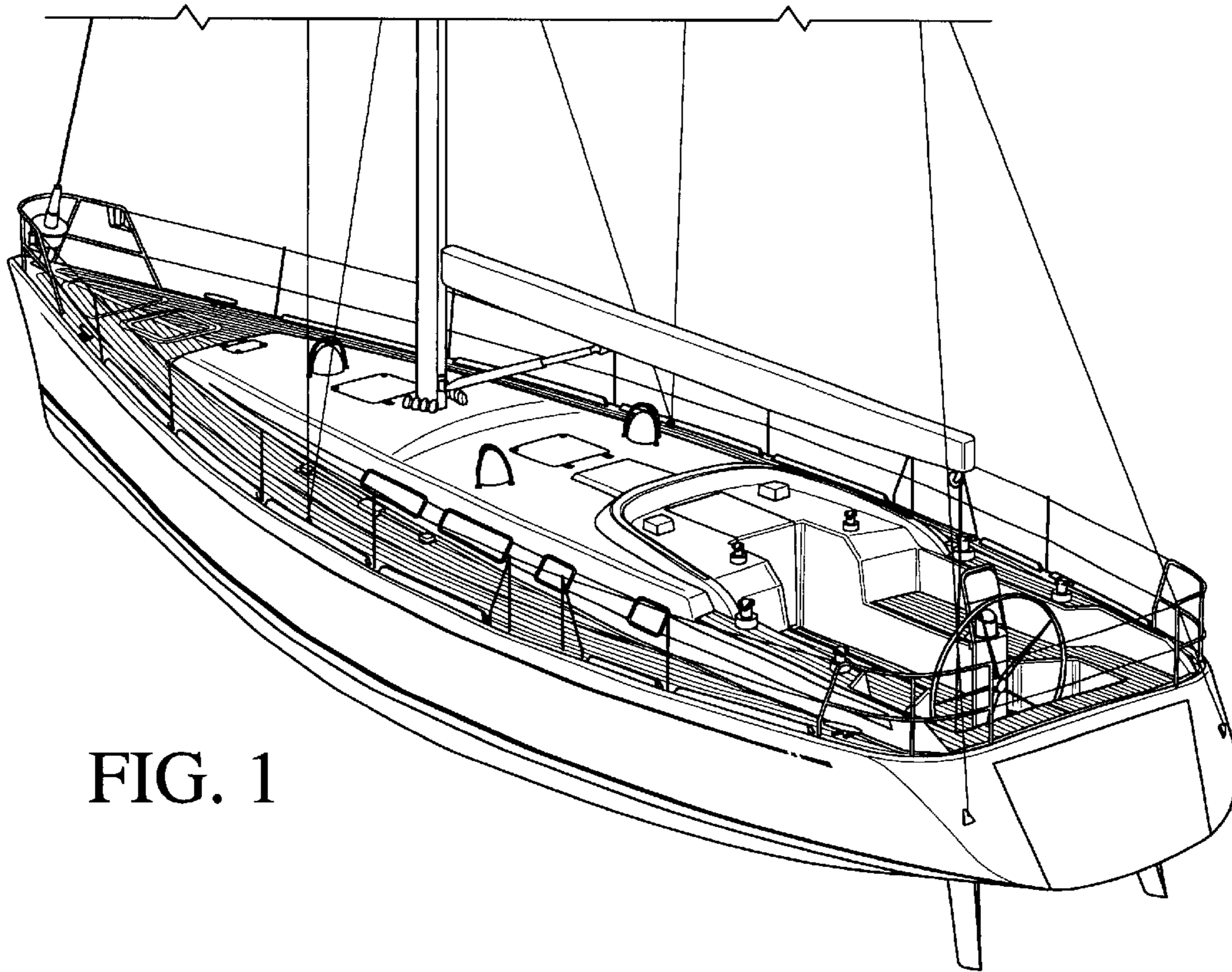

FIG. 1

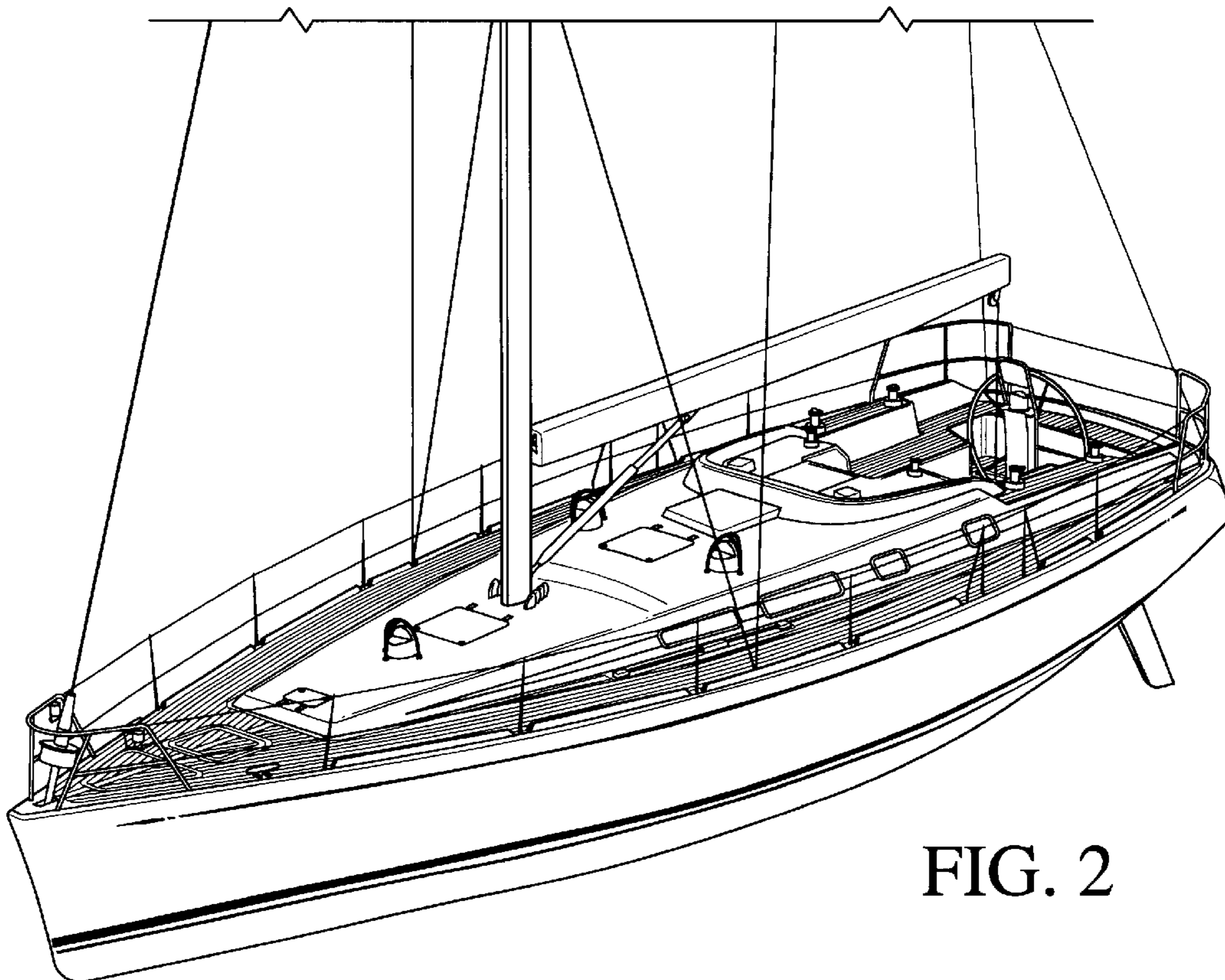

FIG. 2



FIG. 3

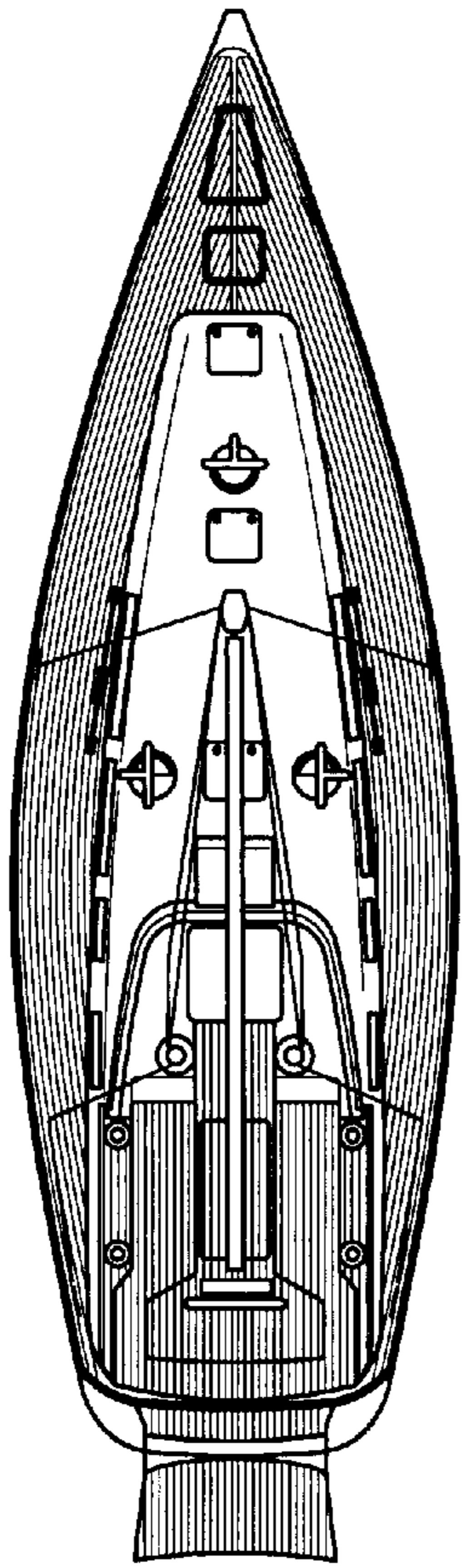

FIG. 4

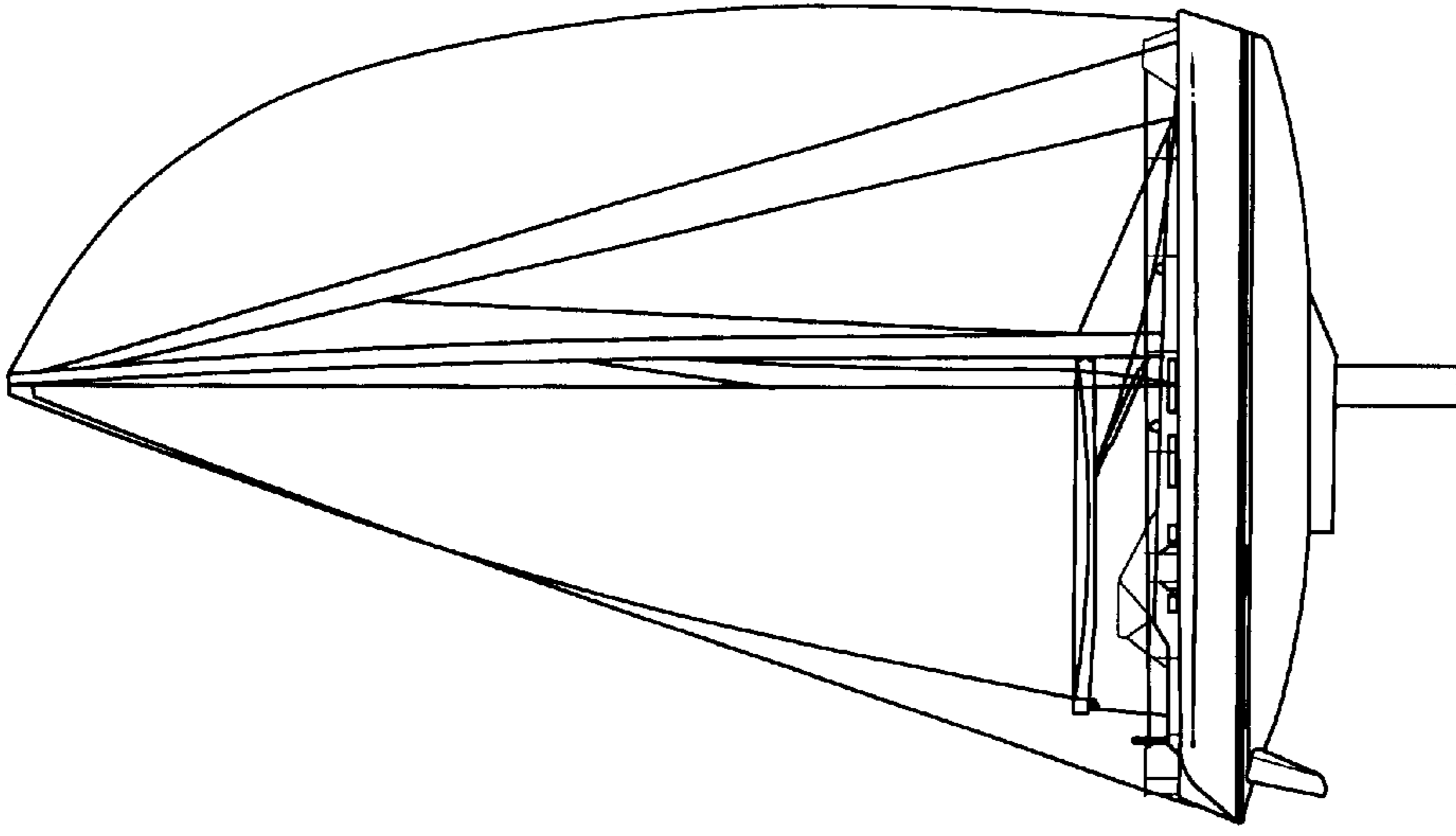
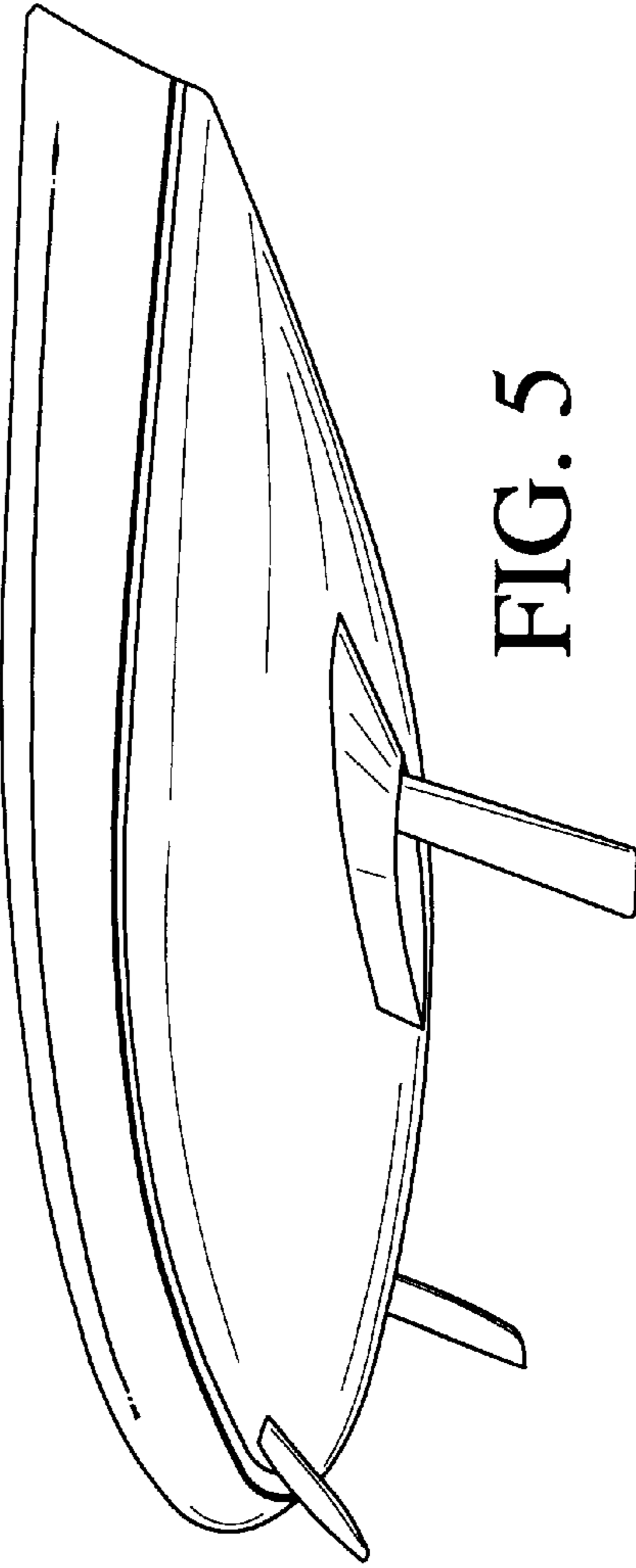

FIG. 5



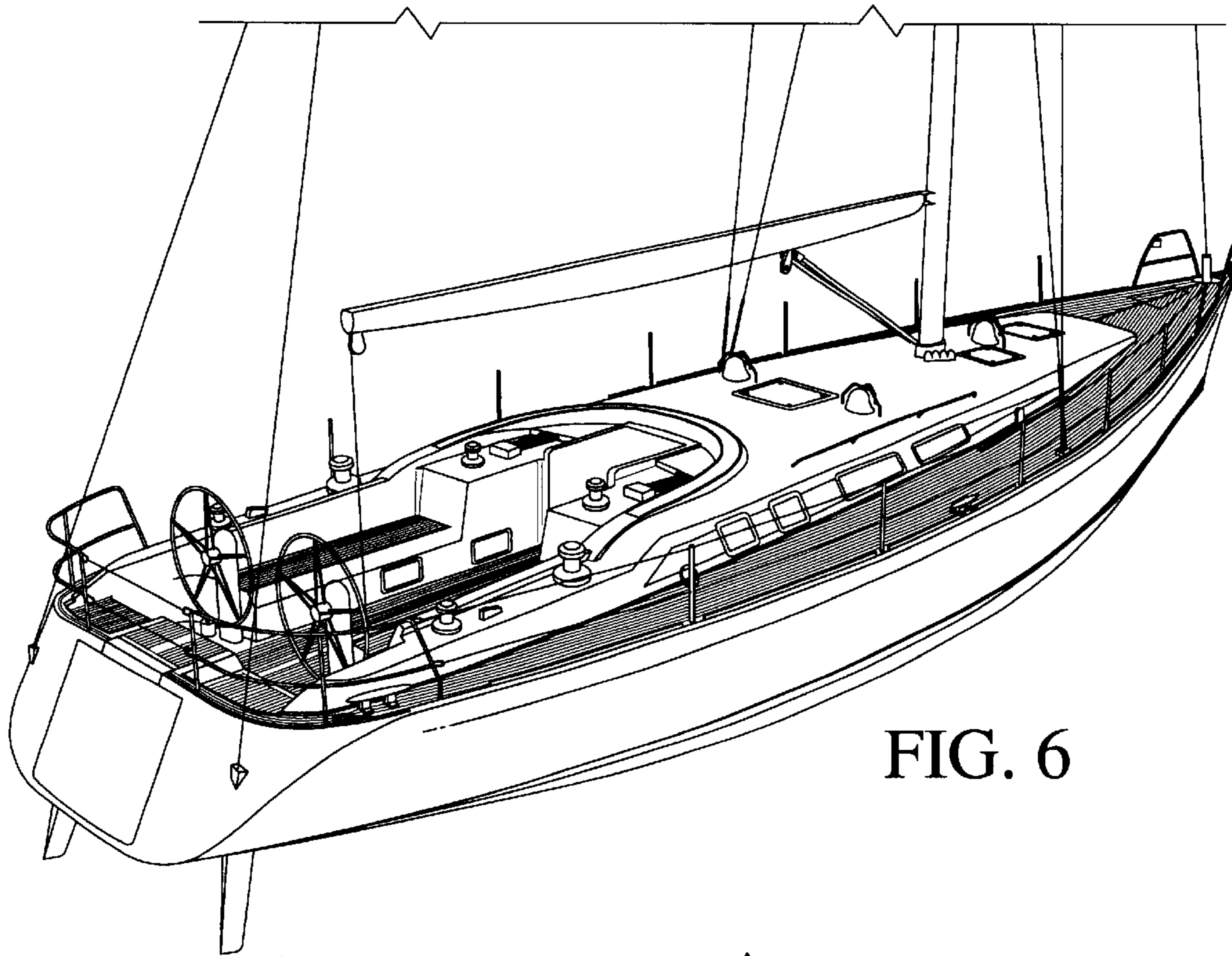

FIG. 6

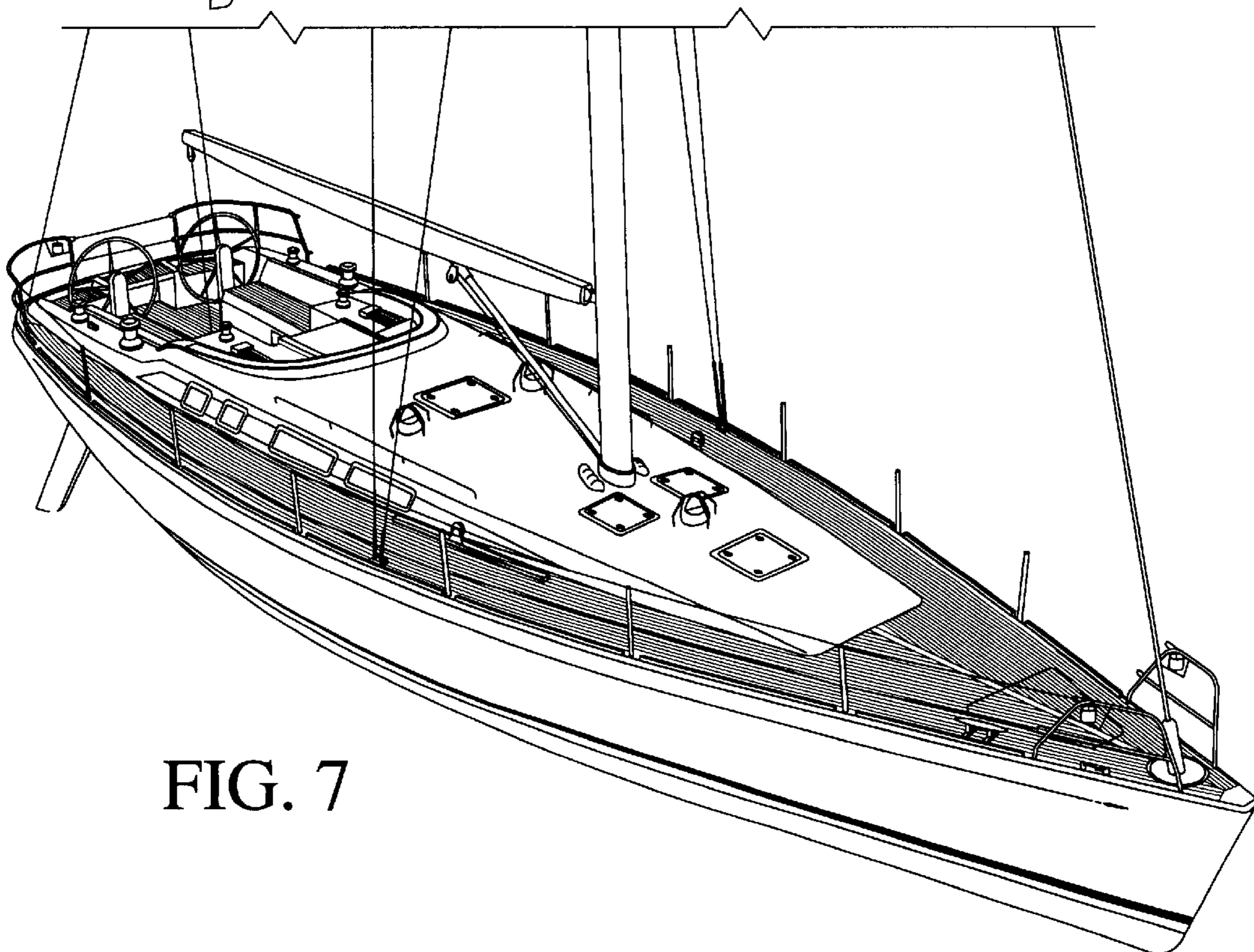

FIG. 7

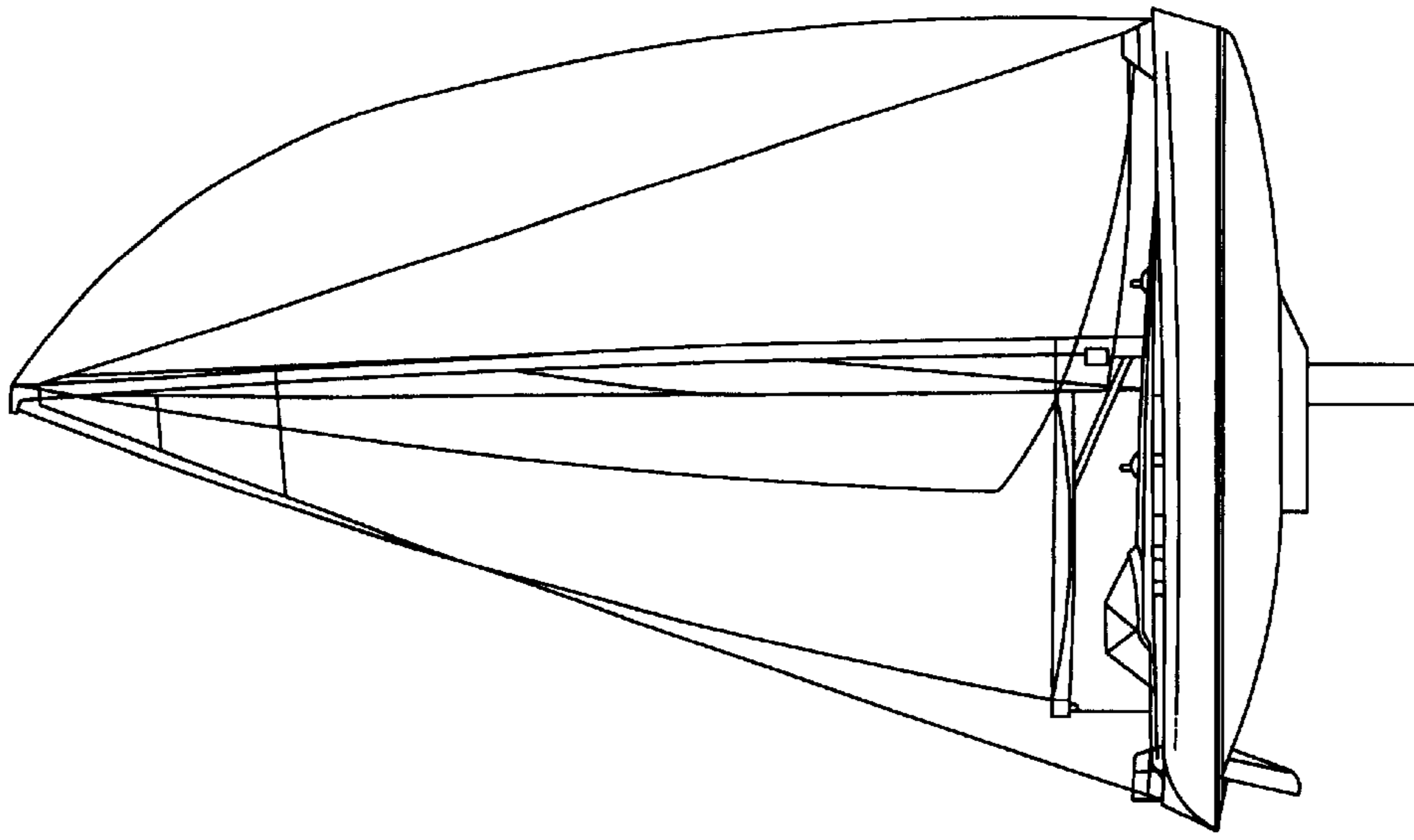

FIG. 9

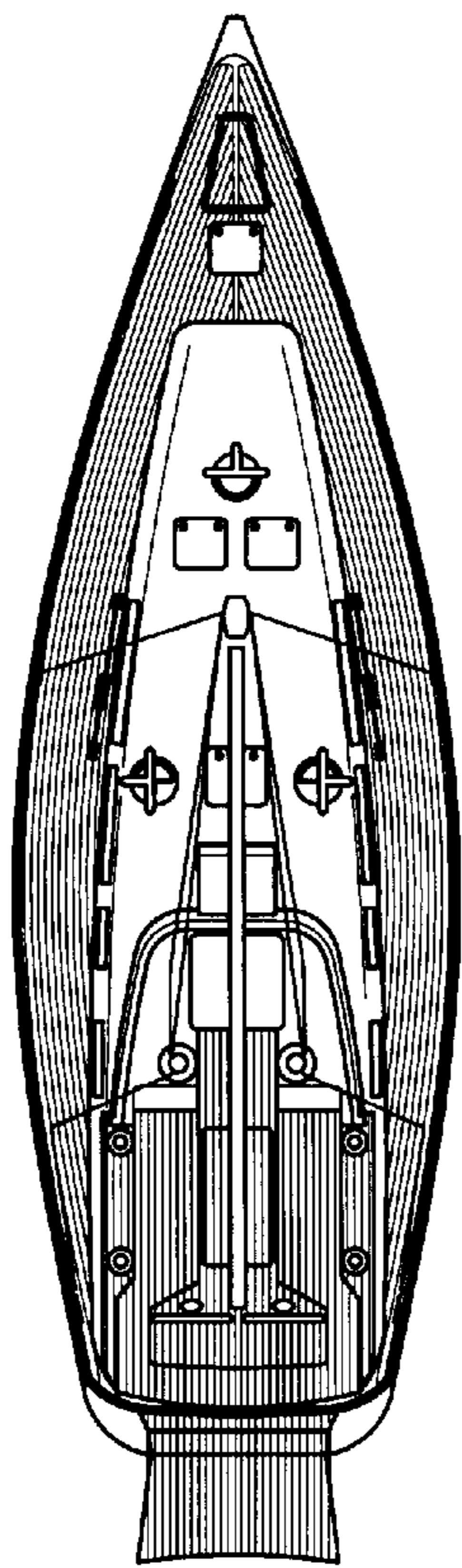

FIG. 8

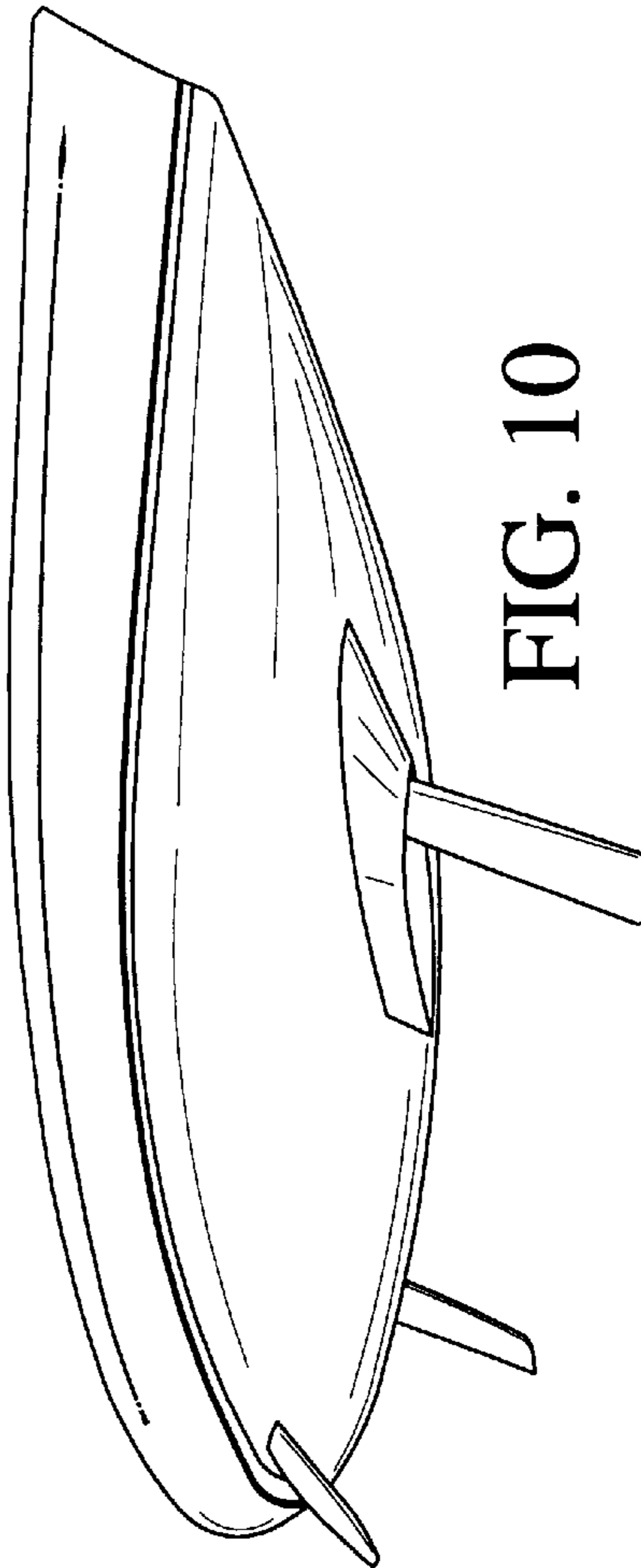

FIG. 10

UNITED STATES PATENT AND TRADEMARK OFFICE  
**CERTIFICATE OF CORRECTION**

PATENT NO. : Des. 531,107 S  
APPLICATION NO. : 29/216093  
DATED : October 31, 2006  
INVENTOR(S) : Frers

Page 1 of 1

It is certified that error appears in the above-identified patent and that said Letters Patent is hereby corrected as shown below:

On title page

-- item (30) Foreign Application Priority Data

Jul. 29, 2004 (IT) .....000209259 --

Signed and Sealed this

Nineteenth Day of December, 2006

A handwritten signature in black ink on a light gray dotted background. The signature reads "Jon W. Dudas" in a cursive style.

JON W. DUDAS

*Director of the United States Patent and Trademark Office*