



US00D530941S

(12) **United States Design Patent** (10) **Patent No.:** **US D530,941 S**  
**Domack et al.** (45) **Date of Patent:** **\*\* Oct. 31, 2006**

(54) **END TABLE**

(75) Inventors: **Randy D. Domack**, Trempealeau, WI (US); **Terry A. Everson**, Blair, WI (US)

(73) Assignee: **Ashley Furniture Industries, Inc.**, Arcadia, WI (US)

(\*\*) Term: **14 Years**

(21) Appl. No.: **29/225,720**

(22) Filed: **Mar. 18, 2005**

(51) **LOC (8) Cl.** ..... **06-03**

(52) **U.S. Cl.** ..... **D6/480**

(58) **Field of Classification Search** ..... D6/480-489, D6/495, 511, 429, 430, 436, 432; 108/153.1, 108/155, 156, 157.1, 161; 248/188, 188.1, 248/188.8

See application file for complete search history.

(56) **References Cited**

**U.S. PATENT DOCUMENTS**

|            |   |         |                |       |        |
|------------|---|---------|----------------|-------|--------|
| D147,806 S | * | 11/1947 | Nieman         | ..... | D6/484 |
| D328,829 S | * | 8/1992  | Wisner         | ..... | D6/484 |
| D341,506 S |   | 11/1993 | Nourse         |       |        |
| D414,354 S |   | 9/1999  | Gower          |       |        |
| D458,771 S | * | 6/2002  | Maitland-Smith | ..... | D6/448 |
| D493,051 S | * | 7/2004  | Restemayer     | ..... | D6/484 |
| D509,375 S | * | 9/2005  | O'Hare         | ..... | D6/425 |

**OTHER PUBLICATIONS**

Broyhill Furniture, "Anhurst: Rectangular End Table", [www.broyhillfurn.com/Index.asp?Action=ProductCatalogItemDetails&CollectionID](http://www.broyhillfurn.com/Index.asp?Action=ProductCatalogItemDetails&CollectionID).  
Broyhill Furniture, [www.broyhillfurn.com/interface/style1/images/broyhill/twoc-main-oc2319-1g.jpg](http://www.broyhillfurn.com/interface/style1/images/broyhill/twoc-main-oc2319-1g.jpg)  
Century Furniture, "The Town & County Collection 421-721-Huntboard", [www.centuryfurniture.com/product-catalog/Items/ShowItem.aspx?CG\\_Item=421-721](http://www.centuryfurniture.com/product-catalog/Items/ShowItem.aspx?CG_Item=421-721).

Century Furniture, "The Silk Road Collection 501-706 Barkol Window Chest", [www.centuryfurniture.com/productcatalog/Items/ShowItem.aspx?CG\\_Item=501-706](http://www.centuryfurniture.com/productcatalog/Items/ShowItem.aspx?CG_Item=501-706).

Century Furniture, "The Complements Collection 407-612 Leather Box on Stand", [www.centuryfurniture.com/product-catalog/Items/ShowItem.aspx?CG\\_Item=407-612](http://www.centuryfurniture.com/product-catalog/Items/ShowItem.aspx?CG_Item=407-612).

Henredon, [www.henredon.com/images/Big/6911-40.jpg](http://www.henredon.com/images/Big/6911-40.jpg).

Lexington, [www.lexington.com/images\\_hires/Tommy\\_Bahama/516-942.jpg](http://www.lexington.com/images_hires/Tommy_Bahama/516-942.jpg).

Lexington Home Brands, "Tommy Bahama Sunset End Table", [www.lexington.com/ProductDetail.cfm?collection=66&room=0&furntype=12&nam](http://www.lexington.com/ProductDetail.cfm?collection=66&room=0&furntype=12&nam).

(Continued)

*Primary Examiner*—Janice E. Seeger

(74) *Attorney, Agent, or Firm*—Patterson, Thunte, Skaar & Christensen, P.A.

(57) **CLAIM**

We claim the ornamental design for a end table, as shown and described.

**DESCRIPTION**

FIG. 1 is a perspective view of an end table according to an embodiment of the invention.

FIG. 2 is a front elevational view of an end table according to an embodiment of the invention.

FIG. 3 is a side elevational view of an end table according to an embodiment of the invention. The elevational view of the opposite side being a mirror image thereof.

FIG. 4 is a top plan view of an end table according to an embodiment of the invention; and,

FIG. 5 is a back elevational view of an end table according to an embodiment of the invention.

The dashed lines represent environmental elements only and form no part of the claimed design.

**1 Claim, 3 Drawing Sheets**

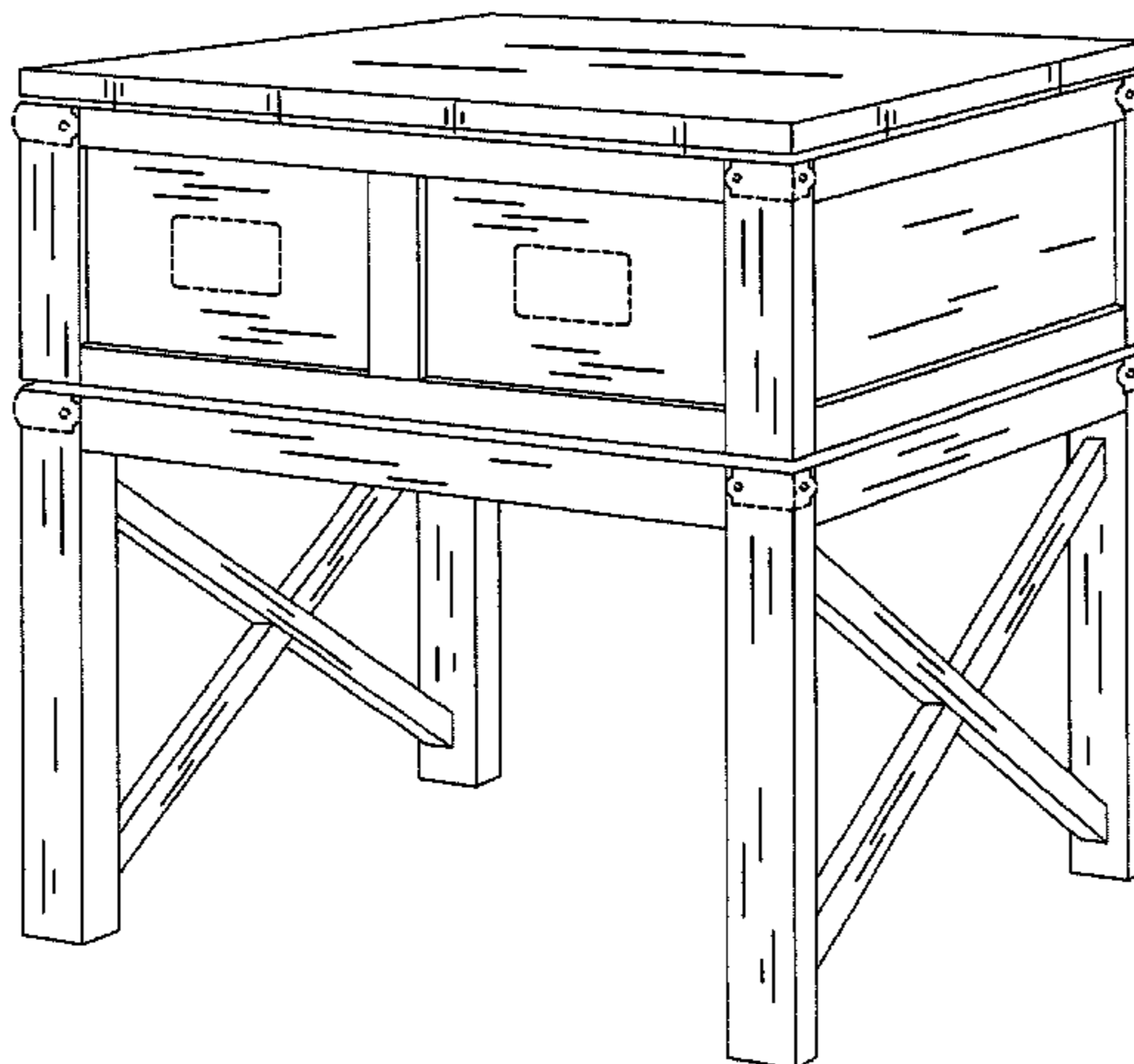

OTHER PUBLICATIONS

Lexington Home Brands, "Woolrich Drawer Lamp Table",  
[www.lexington.com/ProductDetail.cfm?collection=](http://www.lexington.com/ProductDetail.cfm?collection=133&room=0&furntype=12&na)  
[133&room=0&furntype=12&na](http://www.lexington.com/ProductDetail.cfm?collection=133&room=0&furntype=12&na).

Ashley Catalog Photograph, (2003) p. 380, Garnet Hill,  
T755-1-3-4.

Ashley Catalog Photograph, (2003) p. 385, Boulevard  
T970-1-2-3-4.

End Table, [http://www.storehouse.com/store/proding/20B/](http://www.storehouse.com/store/proding/20B/Enlarged/2974.jpg)  
[Enlarged/2974.jpg](http://www.storehouse.com/store/proding/20B/Enlarged/2974.jpg), Oct. 25, 2004, p. 1.

End Table, [http://www.storehouse.com/store/proding/10V/](http://www.storehouse.com/store/proding/10V/Enlarged/V-1-140-01.jpg)  
[Enlarged/V-1-140-01.jpg](http://www.storehouse.com/store/proding/10V/Enlarged/V-1-140-01.jpg), Oct. 25, 2004, p. 1.

Advertisement, Havertys, Makes it Home, p. 1-3.

\* cited by examiner

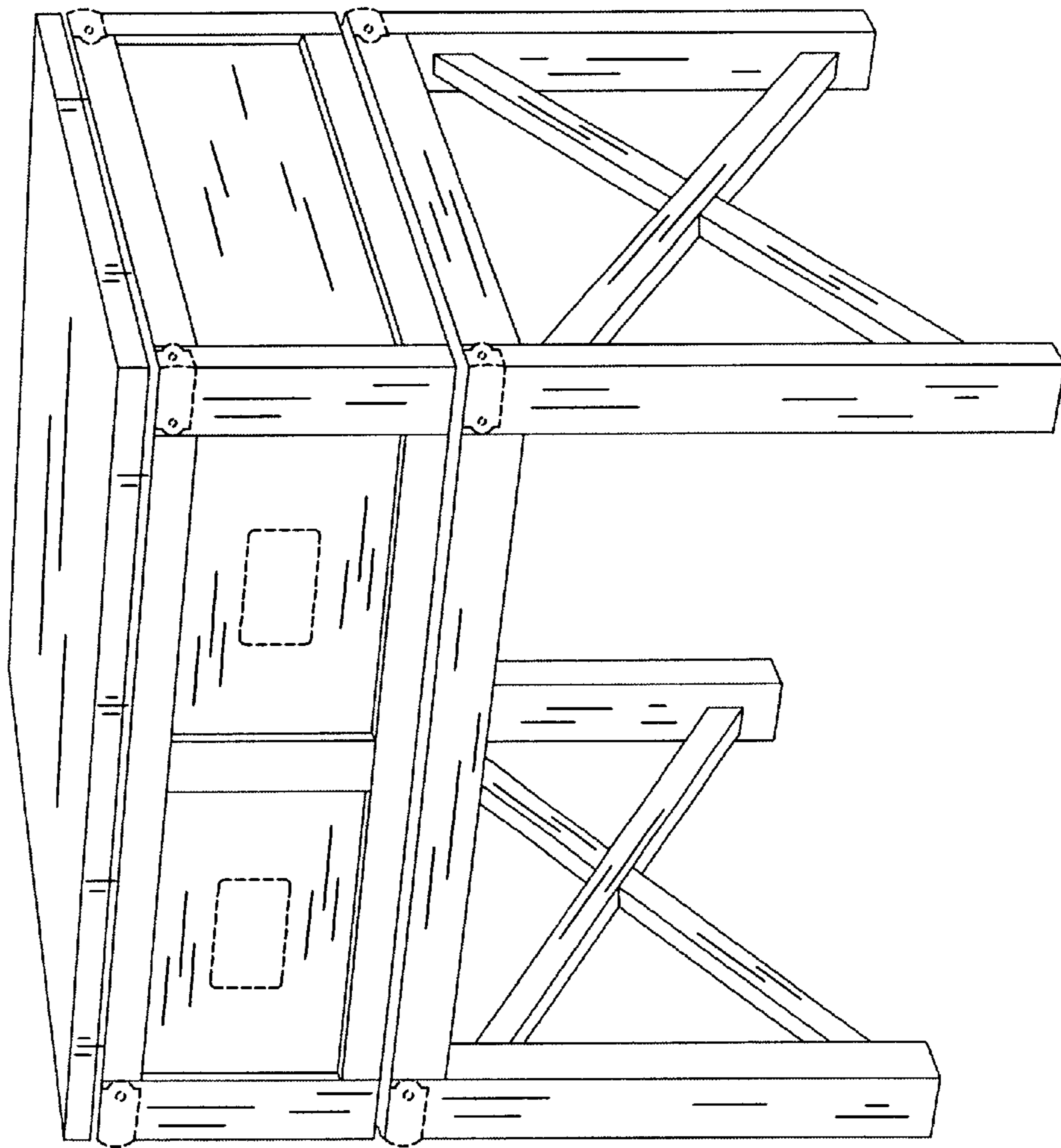

FIG. 1

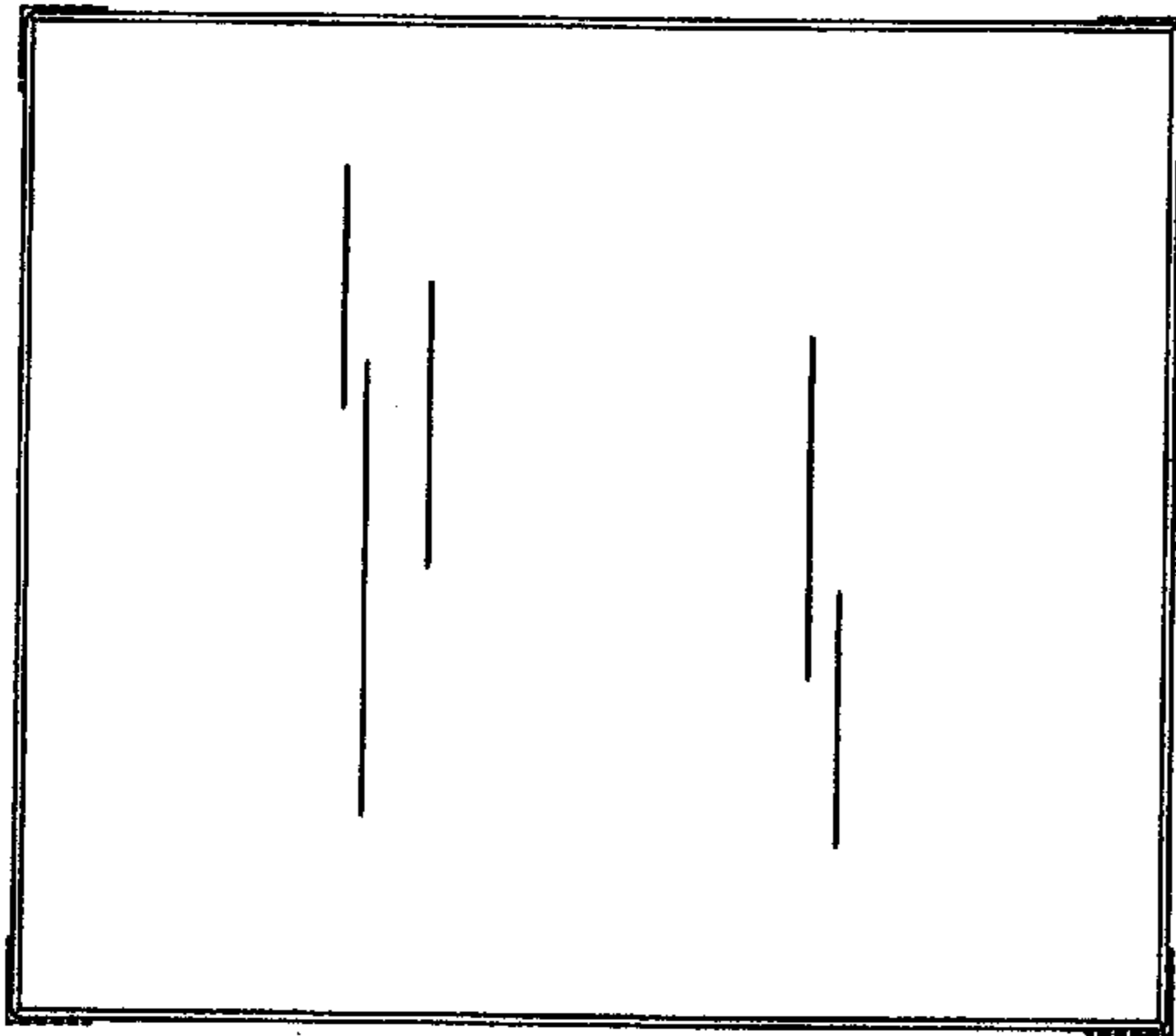

FIG. 4

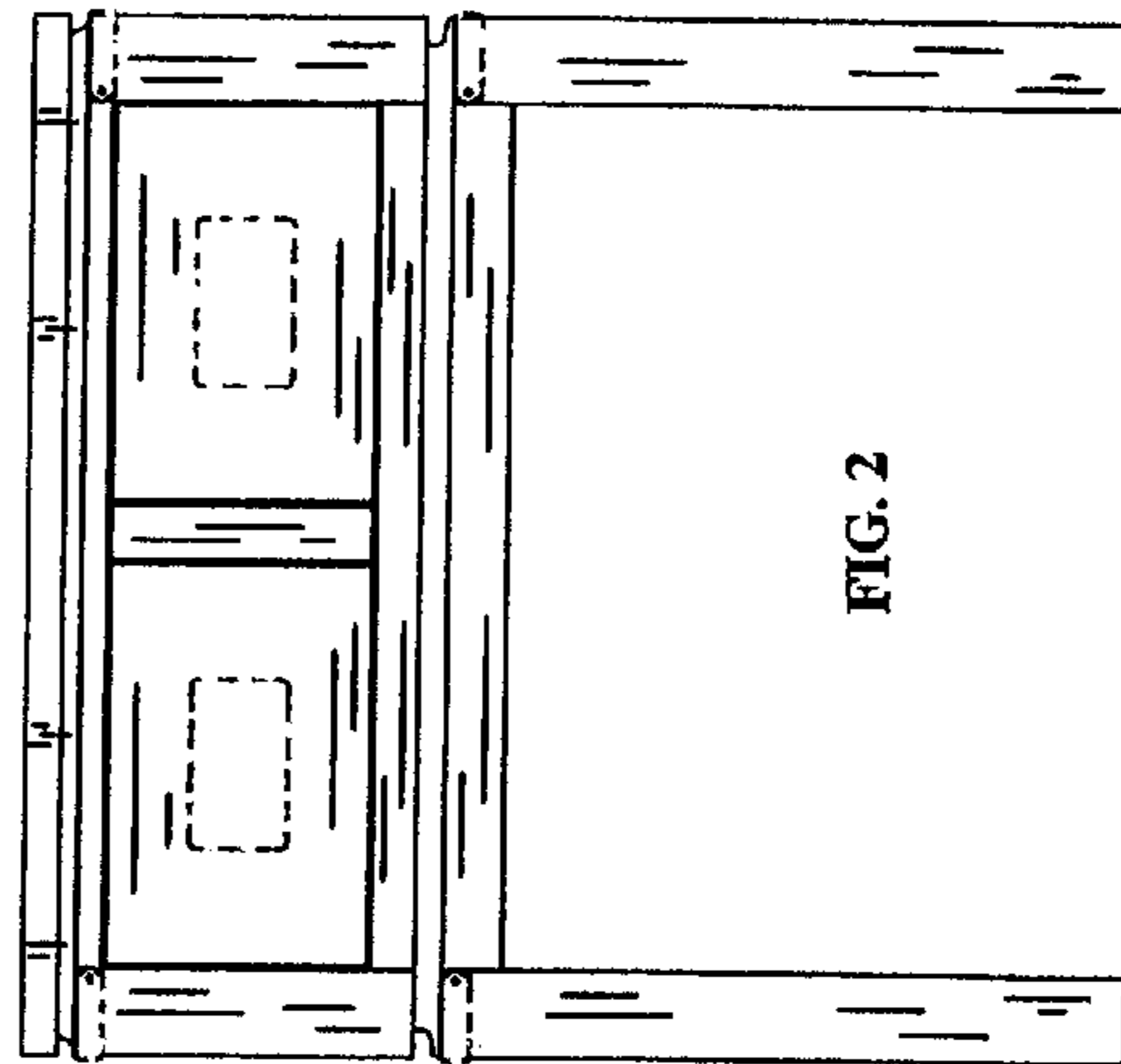

FIG. 2

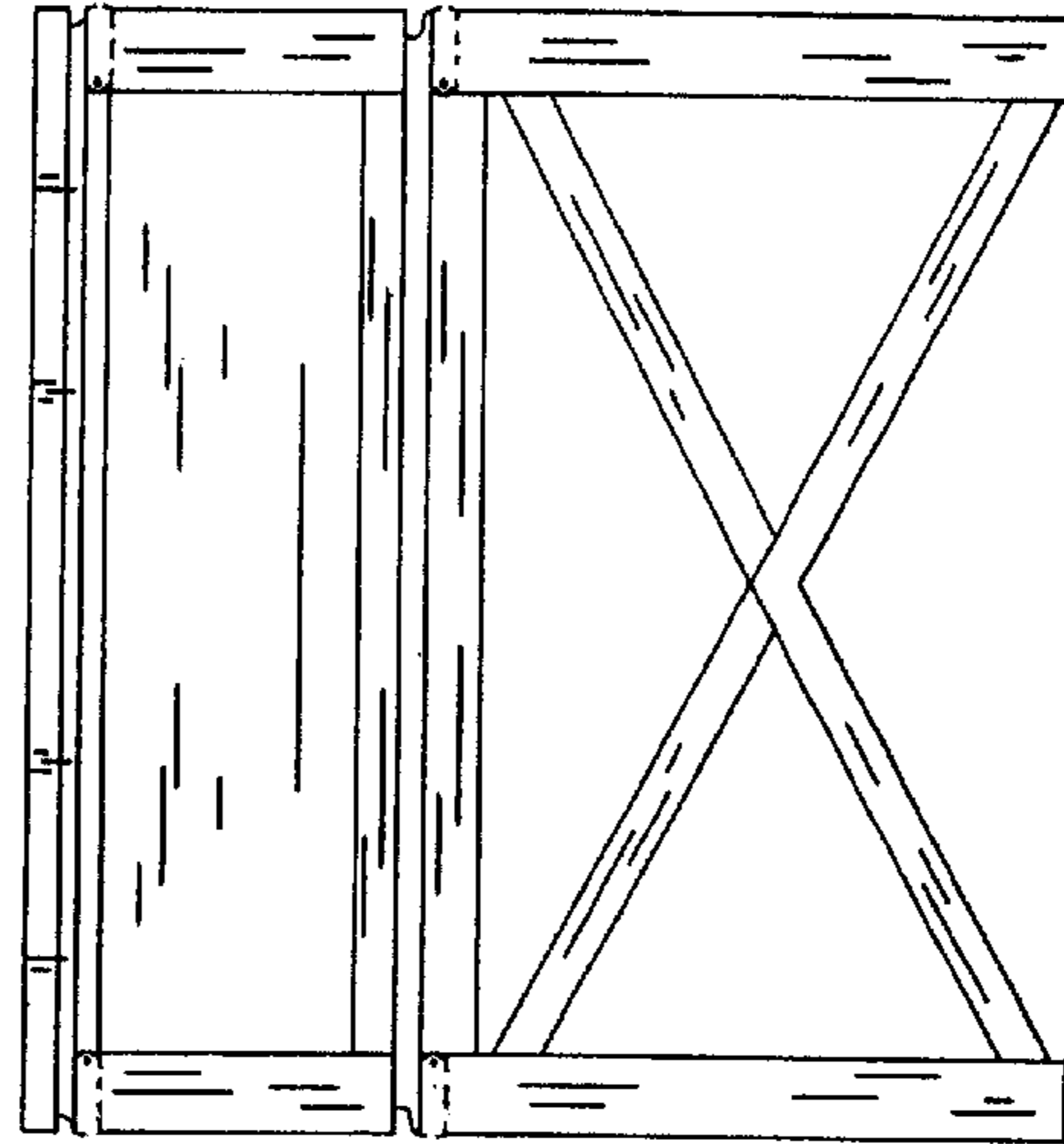

FIG. 3

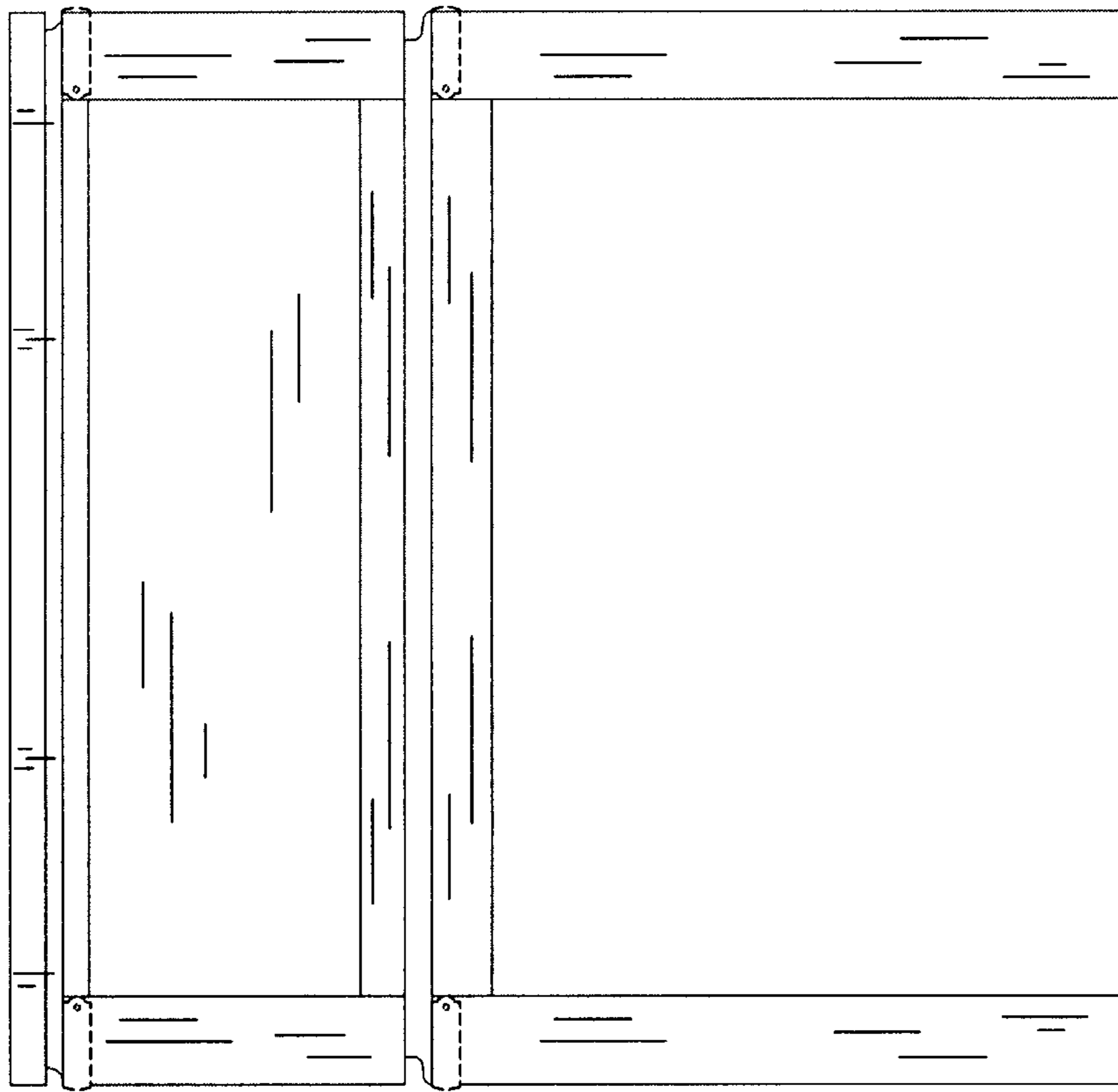

FIG. 5