



US00D530754S

(12) **United States Design Patent** (10) **Patent No.:** **US D530,754 S**  
**Simonetti et al.** (45) **Date of Patent:** **\*\* Oct. 24, 2006**

(54) **PORTION OF A TERMINAL FOR GAMES**

(75) Inventors: **Mario Simonetti**, Via Scipione Rivera (IT); **Antonio Croce**, Via Santa Barbara (IT); **Luciano Piazzai**, Via Adolfo Infante (IT)

(73) Assignee: **Tecnost Sistemi S.p.A.**, Ivera (IT)

(\*\*) Term: **14 Years**

(21) Appl. No.: **29/233,305**

(22) Filed: **Jul. 1, 2005**

**Related U.S. Application Data**

(62) Division of application No. 29/177,880, filed on May 27, 2003, now Pat. No. Des. 507,023.

(30) **Foreign Application Priority Data**

Sep. 20, 2002 (IT) ..... TO200200238

(51) **LOC (8) Cl.** ..... **21-01**

(52) **U.S. Cl.** ..... **D21/329; D21/324**

(58) **Field of Classification Search** ..... D21/300, D21/324, 328-330, 369; D14/496, 462, 463, D14/464; 273/148 B; 463/1, 30-35, 46, 47; D18/36-39, 50-54

See application file for complete search history.

(56) **References Cited**

**U.S. PATENT DOCUMENTS**

D270,360 S \* 8/1983 Wickstead ..... D21/329  
4,536,164 A \* 8/1985 Klawitter ..... 446/143  
D280,834 S 10/1985 Yokoi  
5,213,327 A 5/1993 Kitaue  
D346,408 S \* 4/1994 Lee ..... D23/330  
D358,430 S \* 5/1995 Rissman et al. .... D21/329

D395,458 S 6/1998 Smith et al.  
D410,499 S 6/1999 Smith et al.  
D411,259 S 6/1999 Ishii et al.  
D421,001 S 2/2000 Miyashita  
6,139,432 A \* 10/2000 Watanabe et al. .... 463/31  
D455,793 S 4/2002 Lin  
D476,638 S 7/2003 Tsukahara  
6,688,984 B1 \* 2/2004 Cole ..... 463/46  
6,958,015 B1 \* 10/2005 Luciano et al. .... 463/46

\* cited by examiner

*Primary Examiner*—Prabhakar Deshmukh

(74) *Attorney, Agent, or Firm*—Banner & Witcoff, Ltd.

(57) **CLAIM**

The ornamental design for a portion of a terminal for games, as shown and described.

**DESCRIPTION**

FIG. 1 is a top, front and right perspective view of a portion of a terminal for games showing our new design  
FIG. 2 is a top, front and left perspective view thereof;  
FIG. 3 is a top plan view thereof;  
FIG. 4 is a bottom plan view thereof;  
FIG. 5 is a front view thereof;  
FIG. 6 is a rear view thereof;  
FIG. 7 is a right side view thereof;  
FIG. 8 is a left side view thereof;  
FIG. 9 is a top, front and left perspective view of the portion of a terminal for games thereof with a display lifted up;  
FIG. 10 is a top rear and right perspective view thereof; and,  
FIG. 11 is a left side view thereof.

The broken lines, which define the boundary of the claimed design form no part thereof. The broken line showings of the remainder of the terminal for games various regions thereof are for illustrative purposes only and do not form part of the claimed design.

**1 Claim, 11 Drawing Sheets**

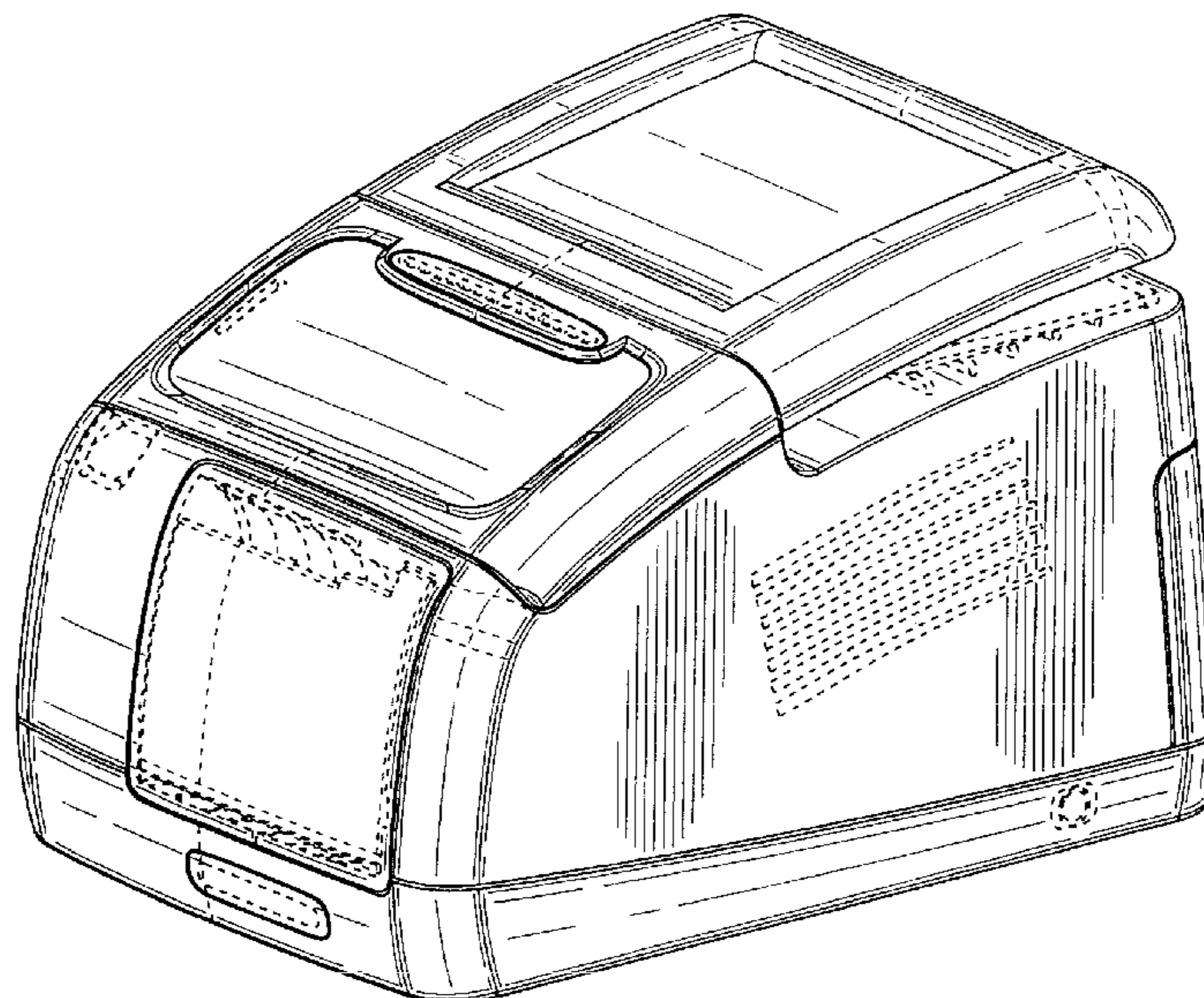

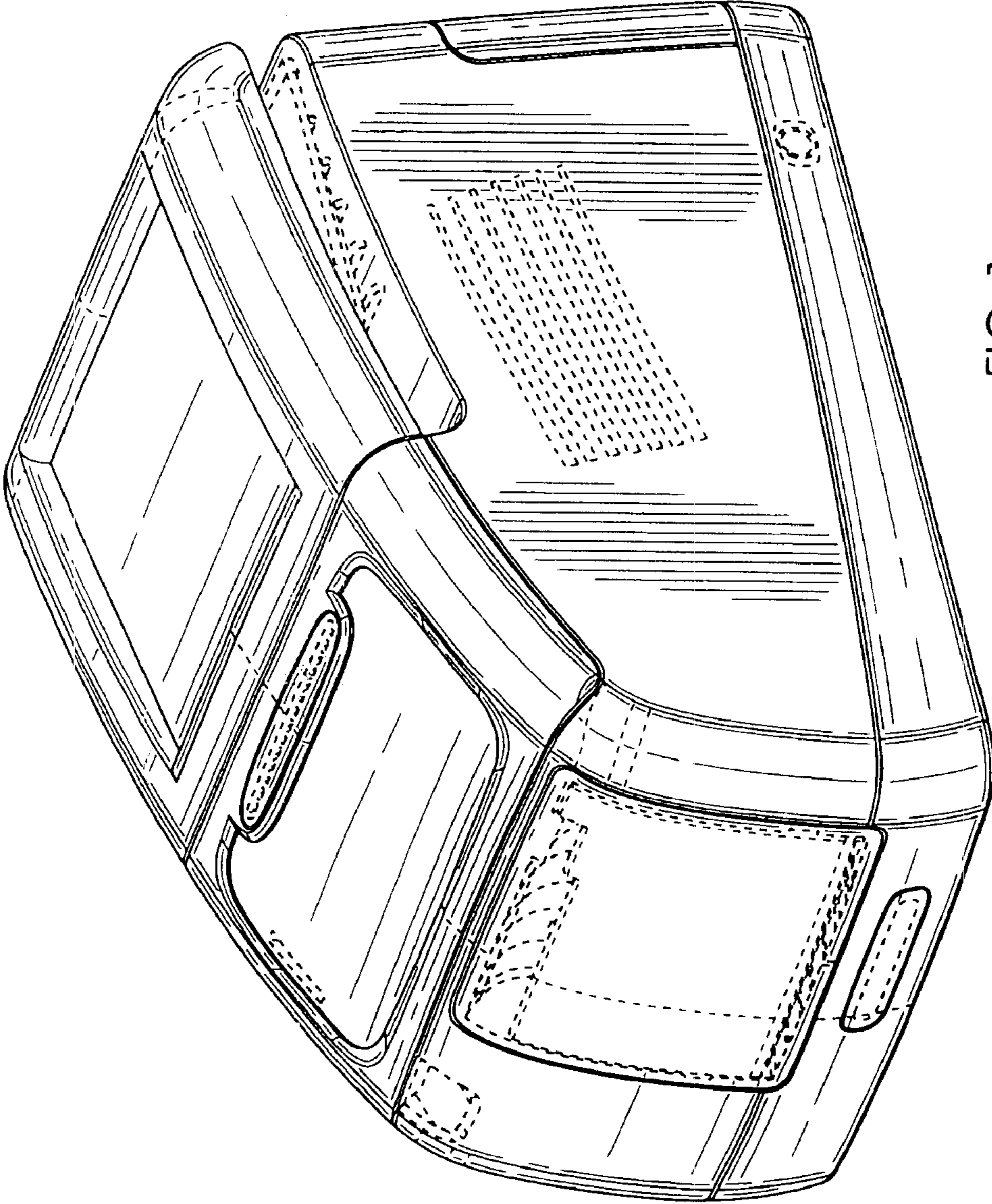

FIG. 1

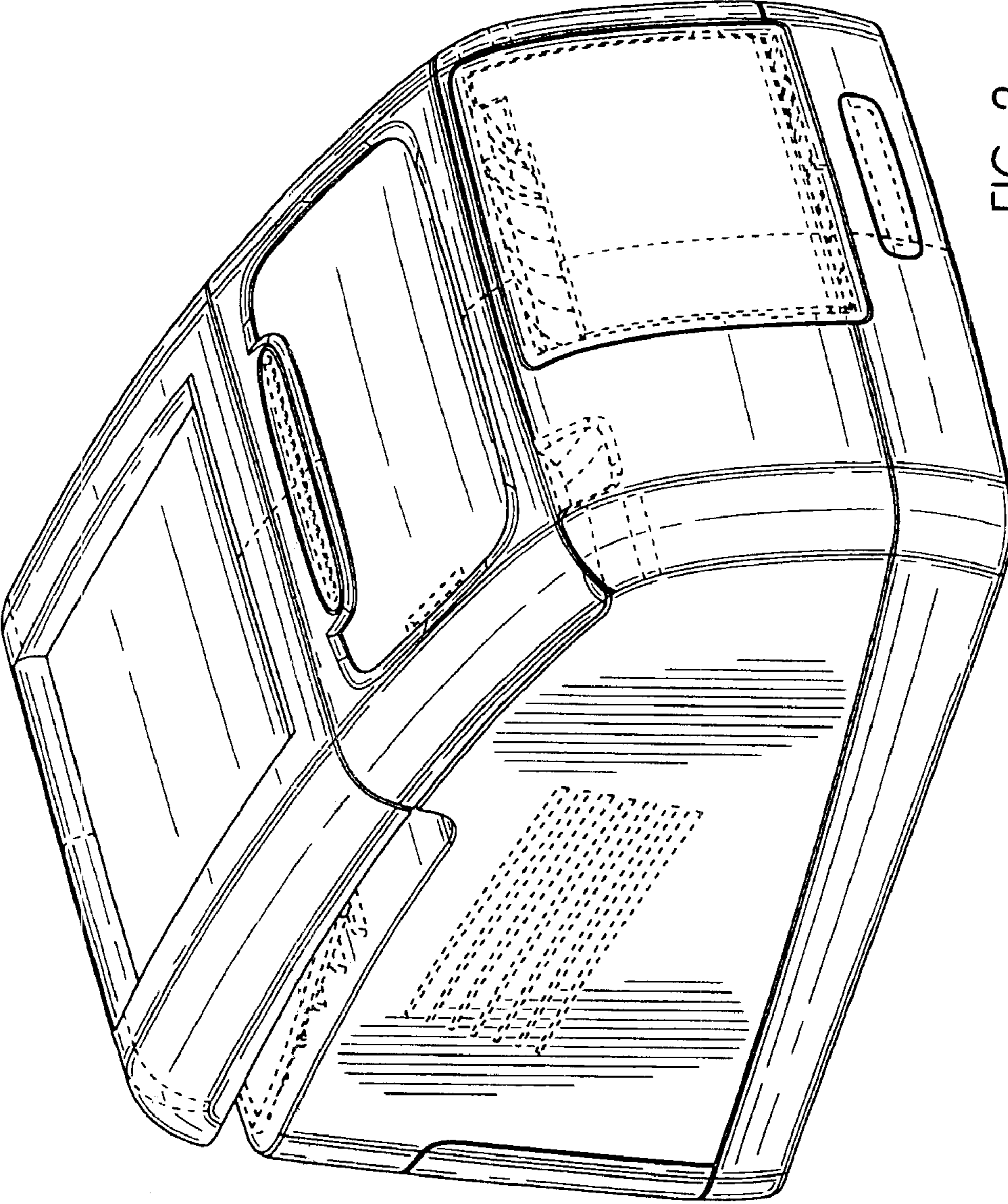

FIG. 2

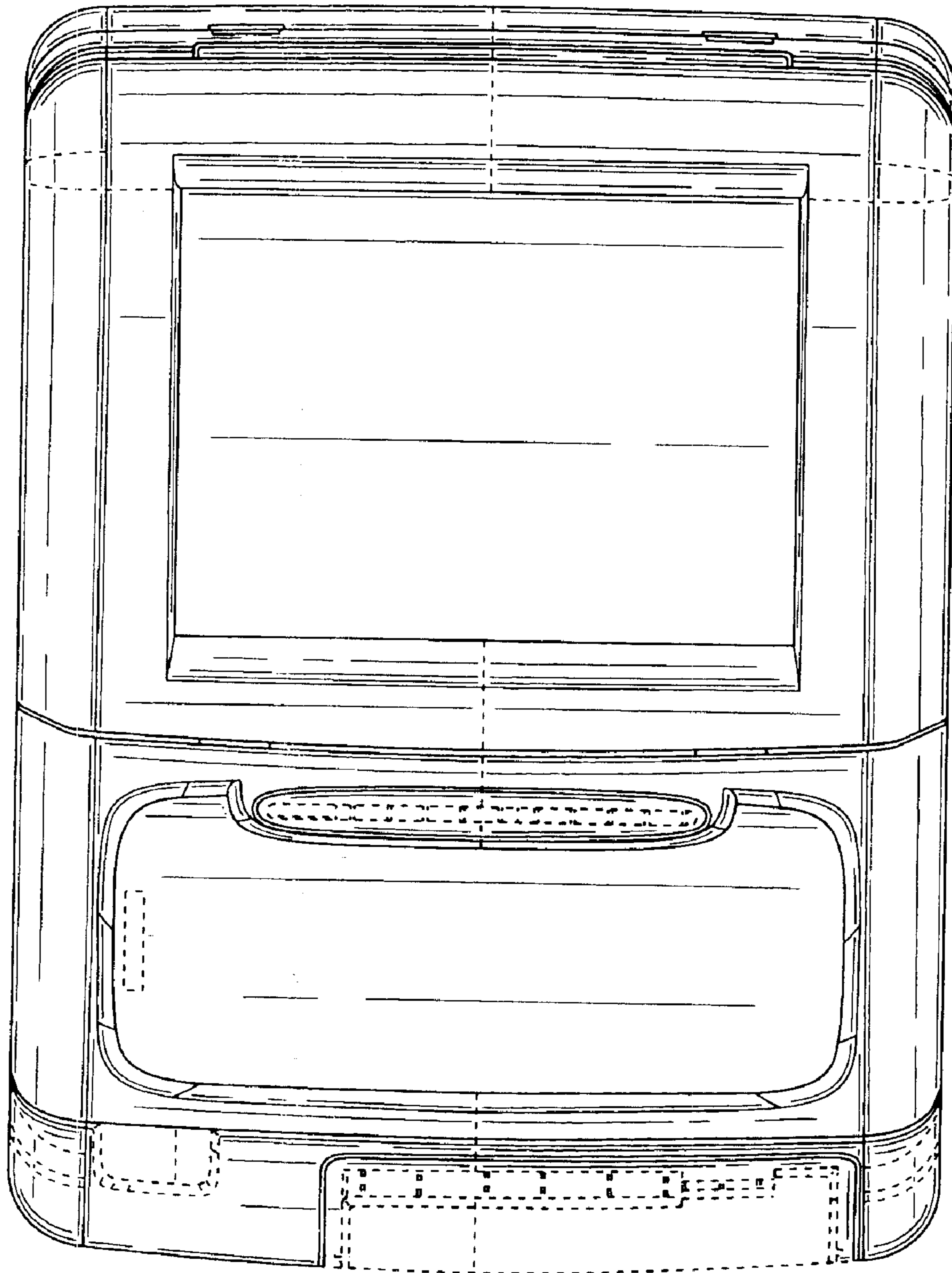

FIG. 3

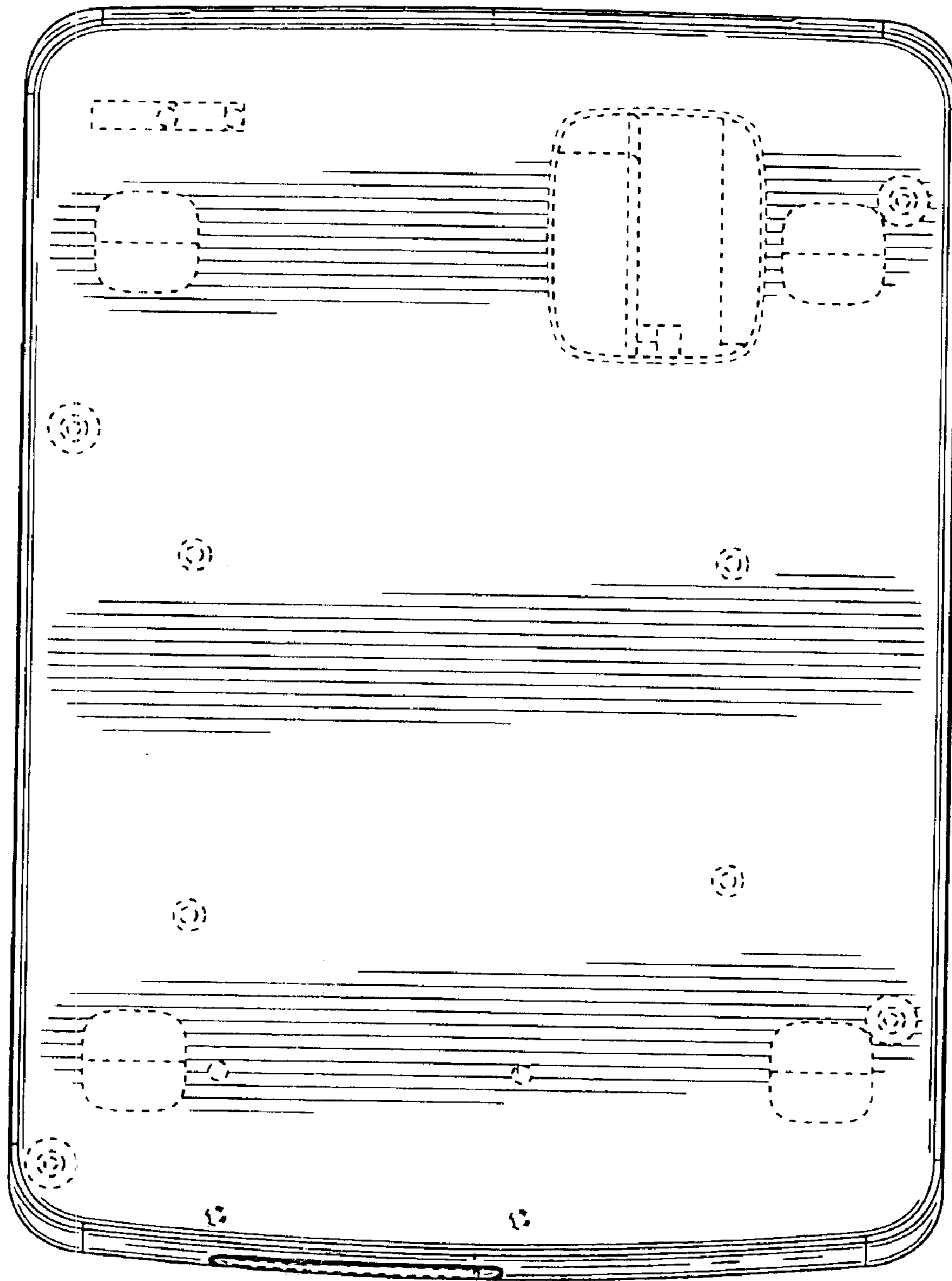

FIG. 4

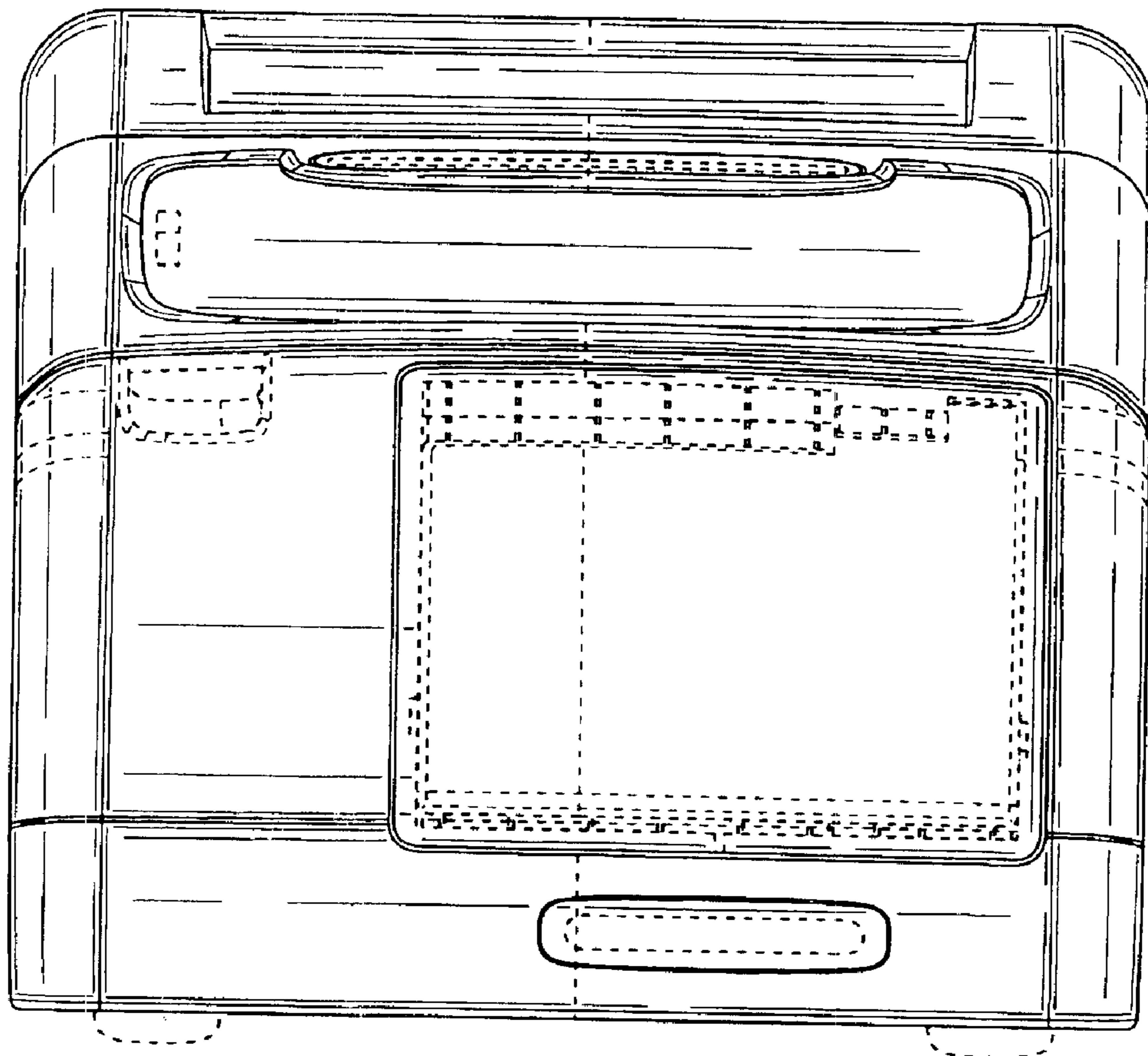

FIG. 5

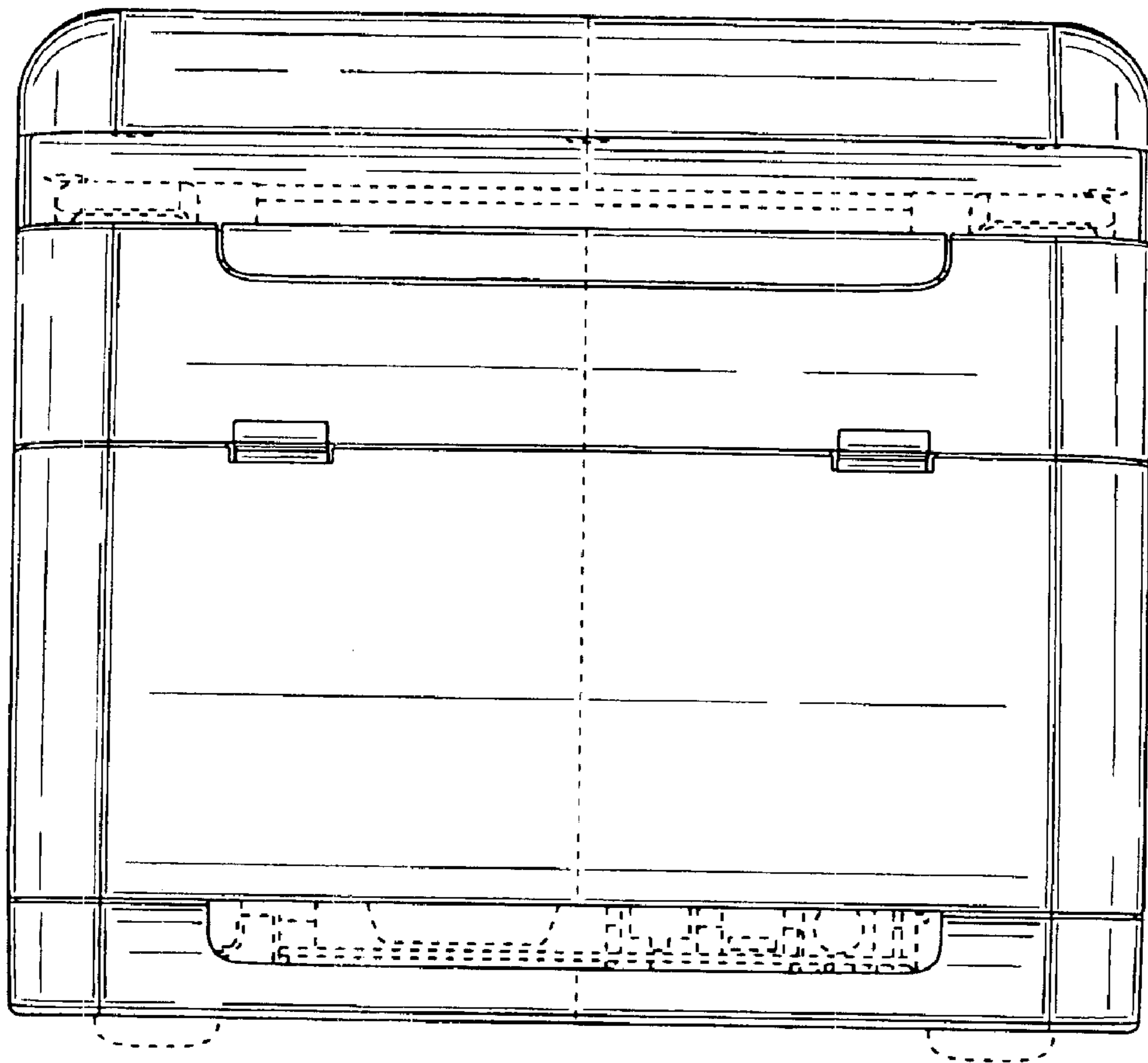

FIG. 6

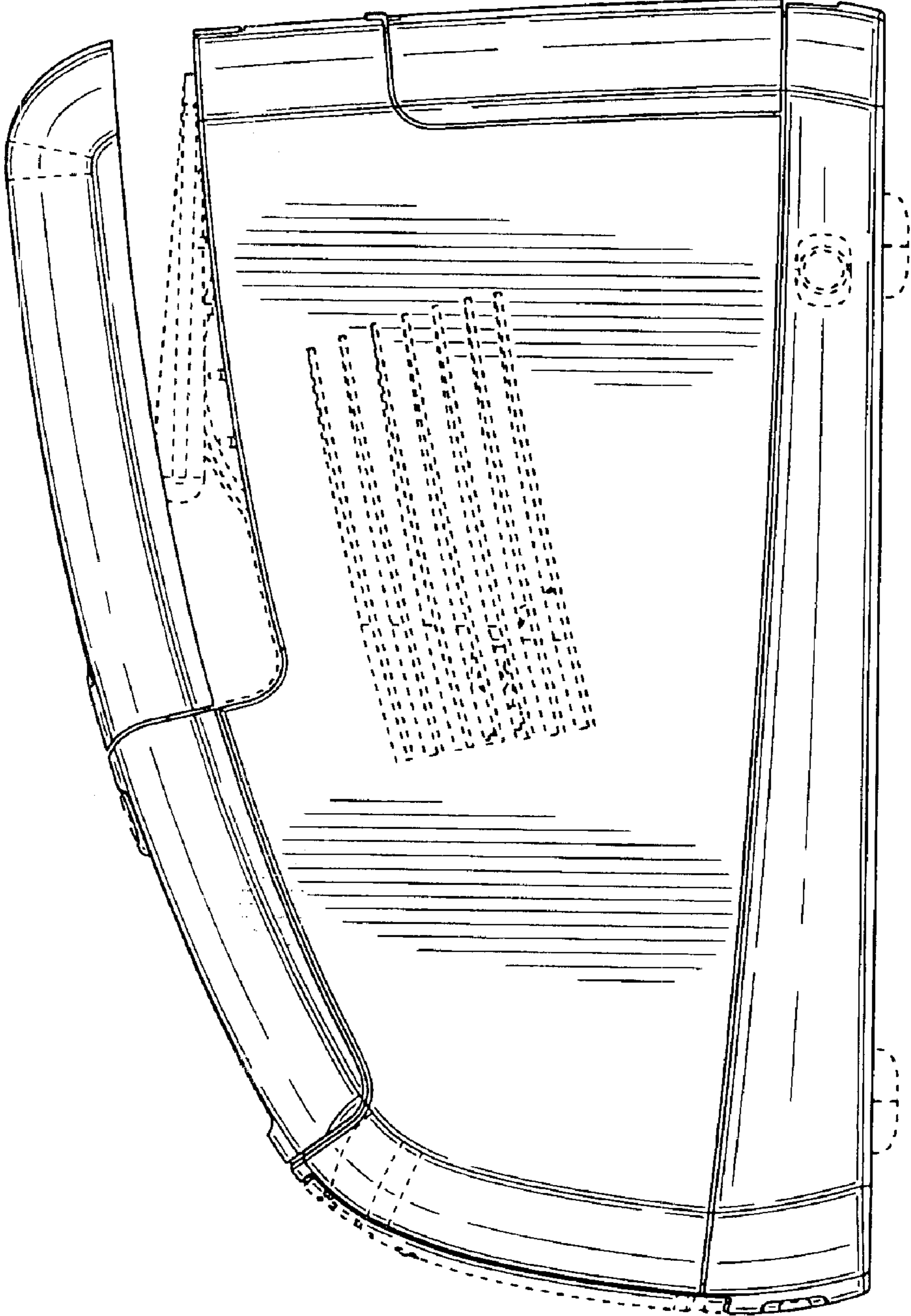

FIG. 7



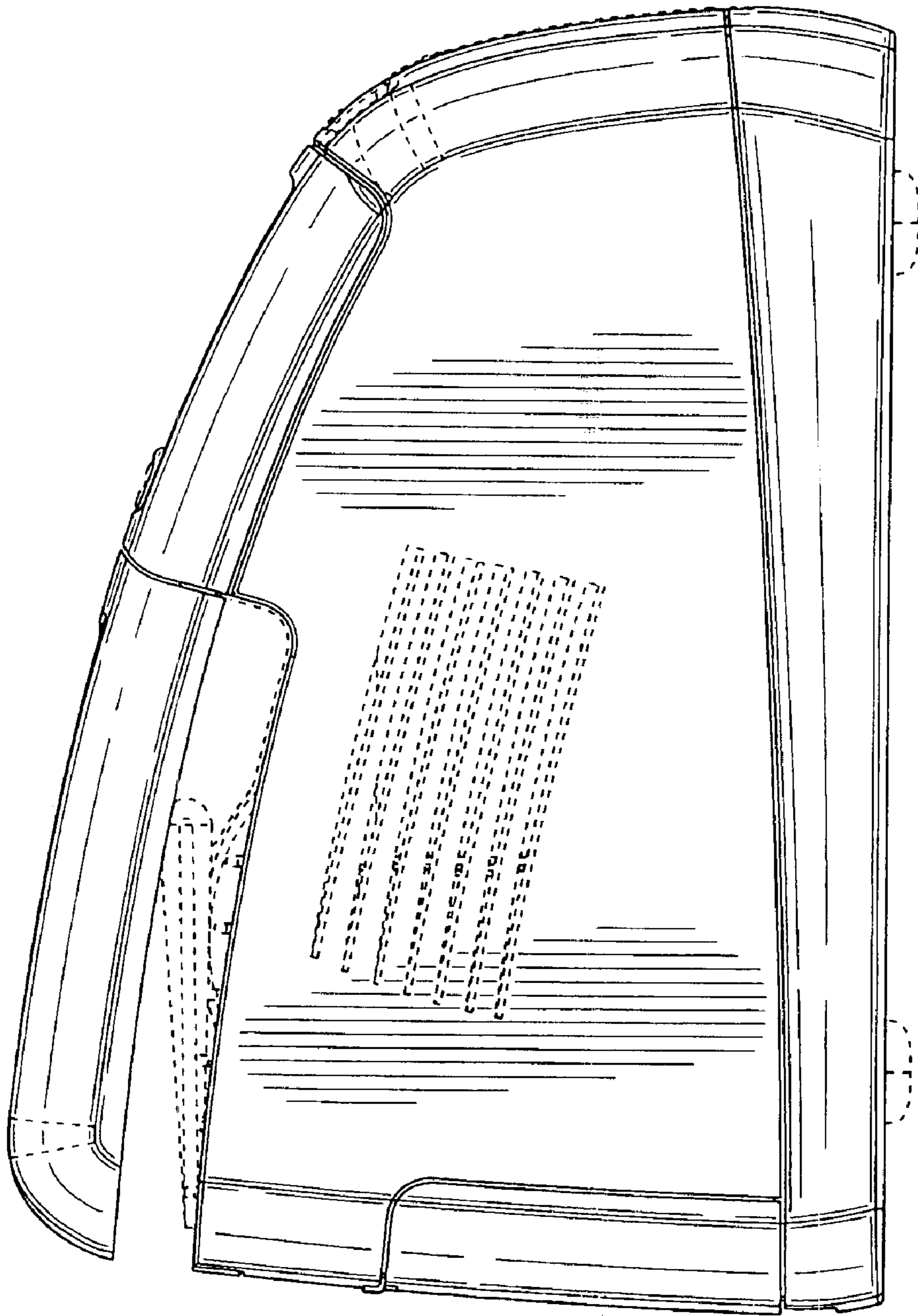

FIG. 8

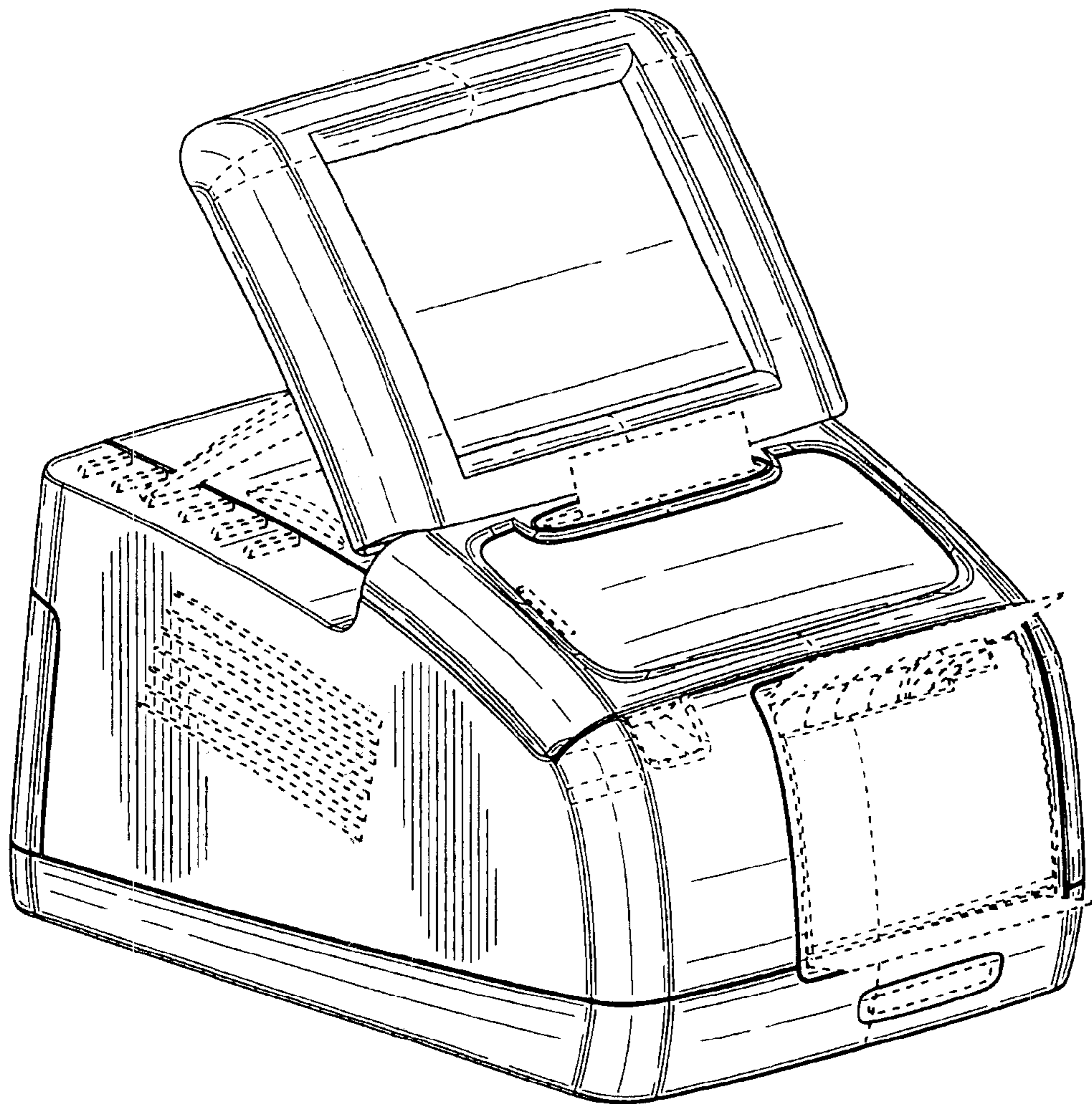

FIG. 9

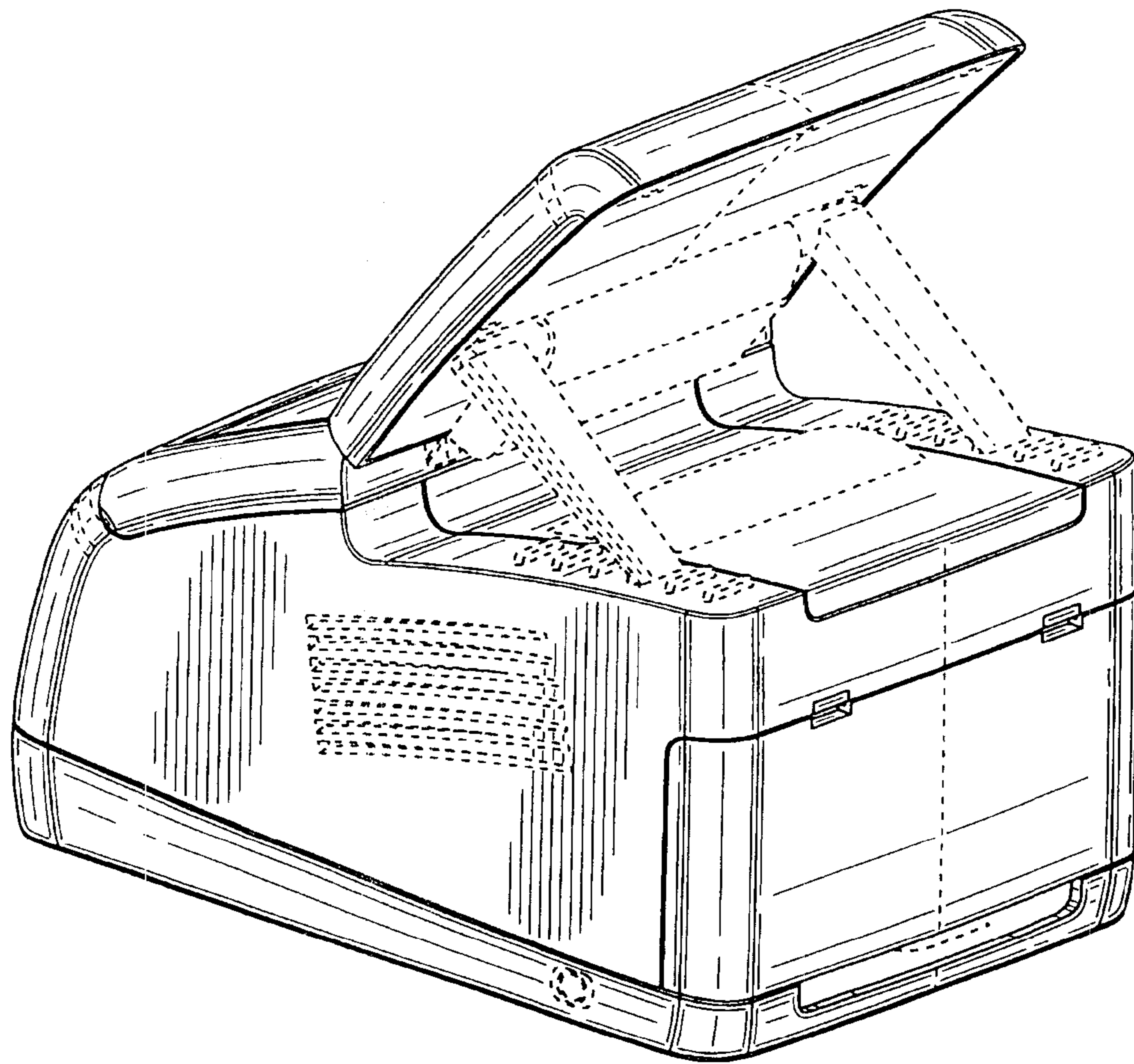

FIG. 10

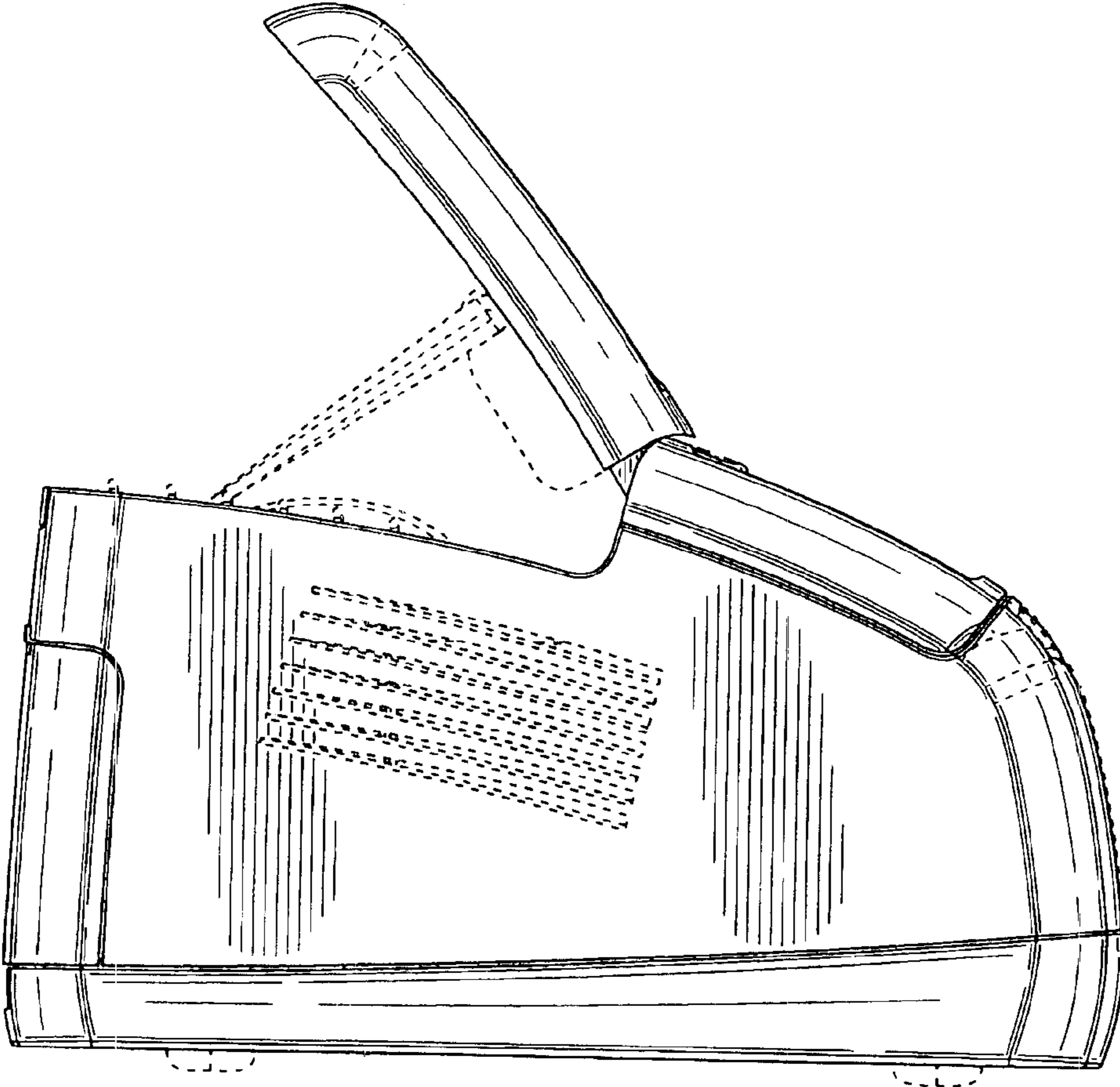

FIG. 11