



US00D530659S

(12) **United States Design Patent**
Guering

(10) **Patent No.:** **US D530,659 S**

(45) **Date of Patent:** **** Oct. 24, 2006**

(54) **AIRCRAFT**

(75) Inventor: **Bernard Guering**, Montrabe (FR)

(73) Assignee: **Airbus France**, Toulouse (FR)

(**) Term: **14 Years**

(21) Appl. No.: **29/231,705**

(22) Filed: **Jun. 9, 2005**

(51) **LOC (8) Cl.** **12-12**

(52) **U.S. Cl.** **D12/319**

(58) **Field of Classification Search** D12/319-345;
244/35 A, 45 A, 118.5, 119, 130
See application file for complete search history.

(56) **References Cited**

U.S. PATENT DOCUMENTS

D417,639 S	*	12/1999	Carichner et al.	D12/16.1
D431,055 S	*	9/2000	Tachau et al.	D21/448
D437,284 S	*	2/2001	Knutson et al.	D12/319
D464,604 S	*	10/2002	Jamgarov	D12/319
D501,178 S	*	1/2005	Han	D12/319

D504,862 S	*	5/2005	Seidel	D12/319
D515,013 S	*	2/2006	Eatkins et al.	D12/319

* cited by examiner

Primary Examiner—Marcus A. Jackson

(74) *Attorney, Agent, or Firm*—Young & Thompson

(57) **CLAIM**

The ornamental design for an aircraft, as shown and described.

DESCRIPTION

FIG. 1 is a top, front and side perspective view of an aircraft showing my new design;
 FIG. 2 is a top, rear and side perspective view thereof;
 FIG. 3 is a bottom, rear and side perspective view thereof;
 FIG. 4 is a front elevational view thereof;
 FIG. 5 is a side elevational view thereof from the left of FIG. 4, the side elevational view from the right of FIG. 4 being the mirror image thereof;
 FIG. 6 is a rear elevational view thereof; and,
 FIG. 7 is a top plan view thereof.

1 Claim, 7 Drawing Sheets

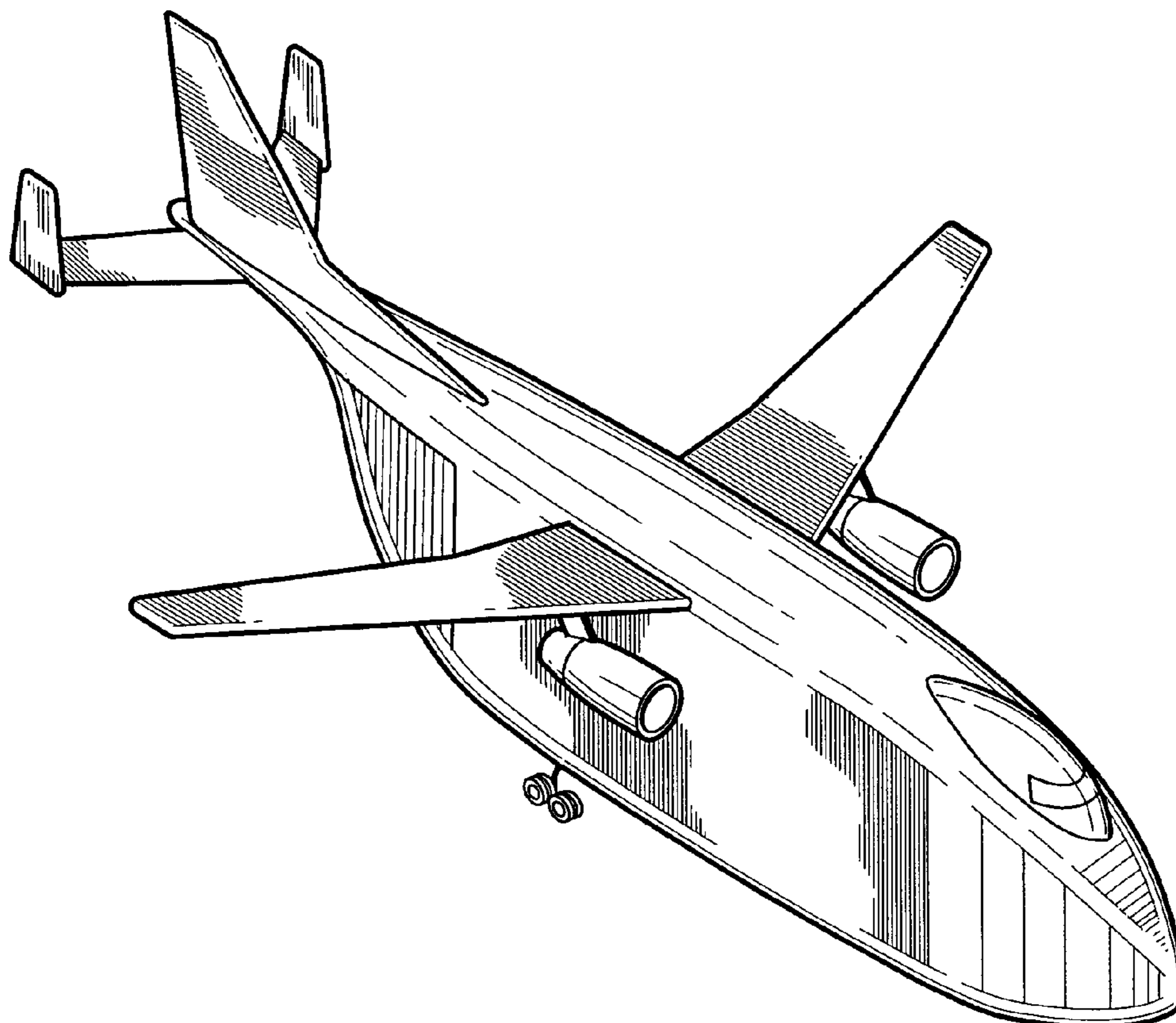

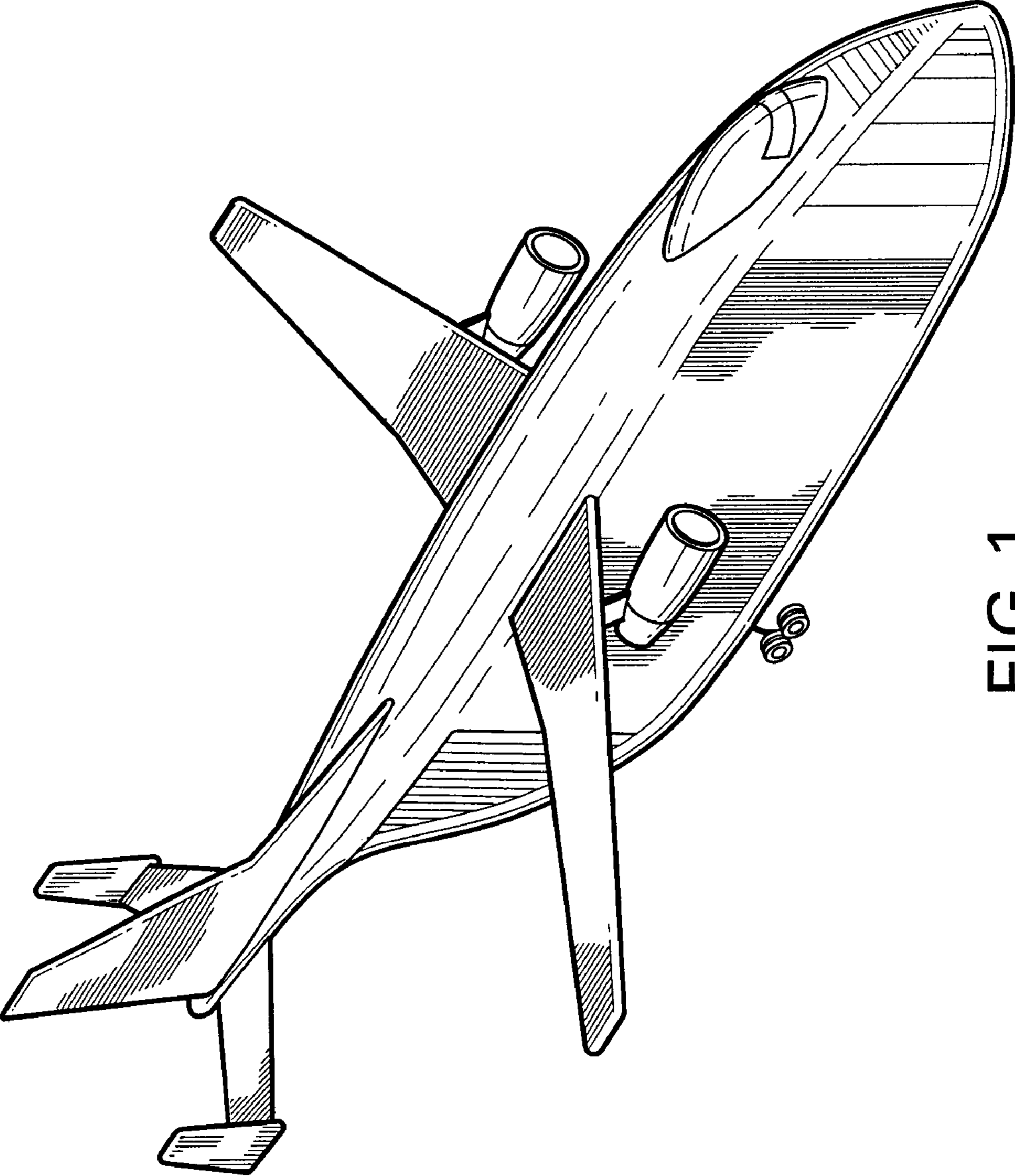

FIG. 1

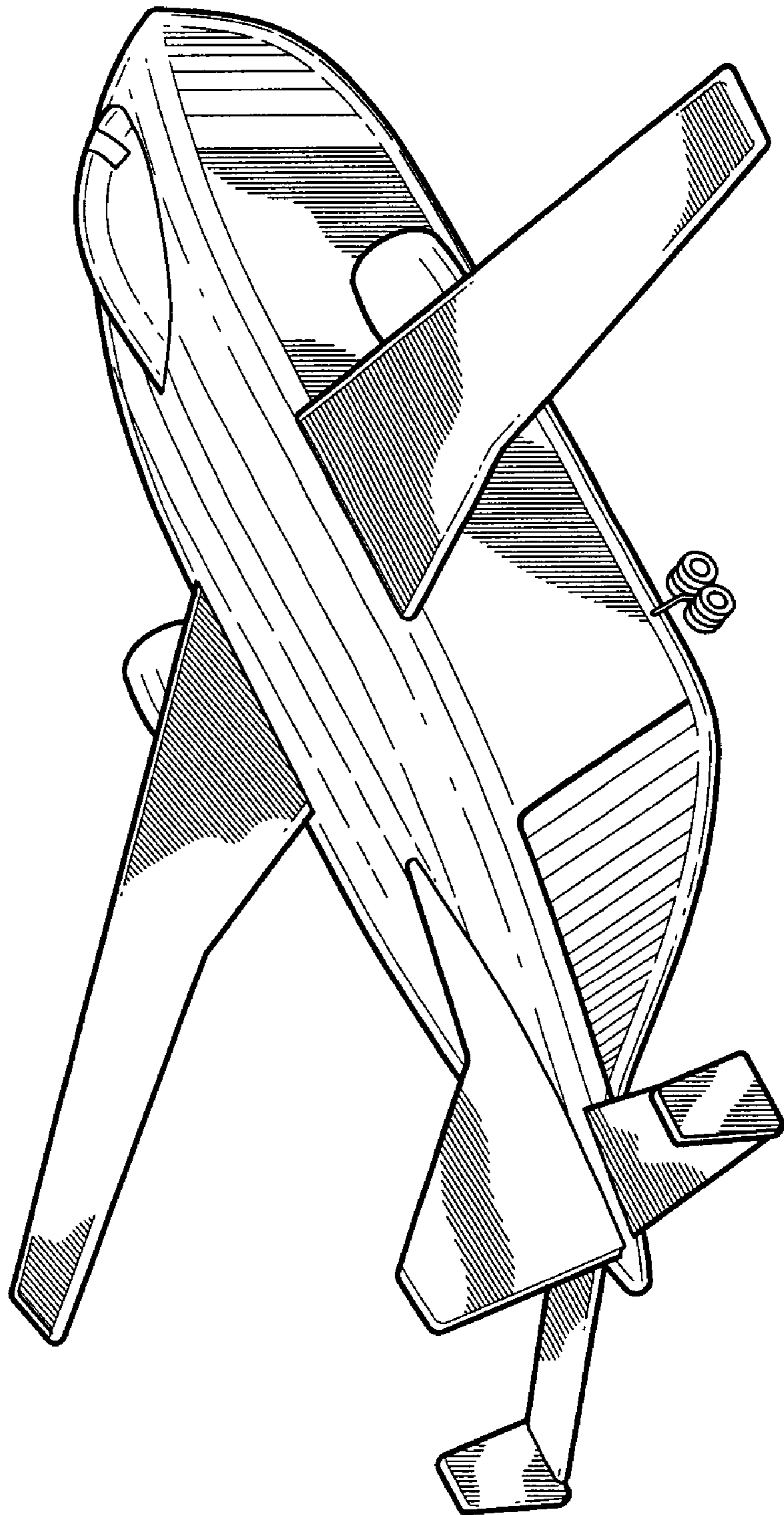

FIG. 2

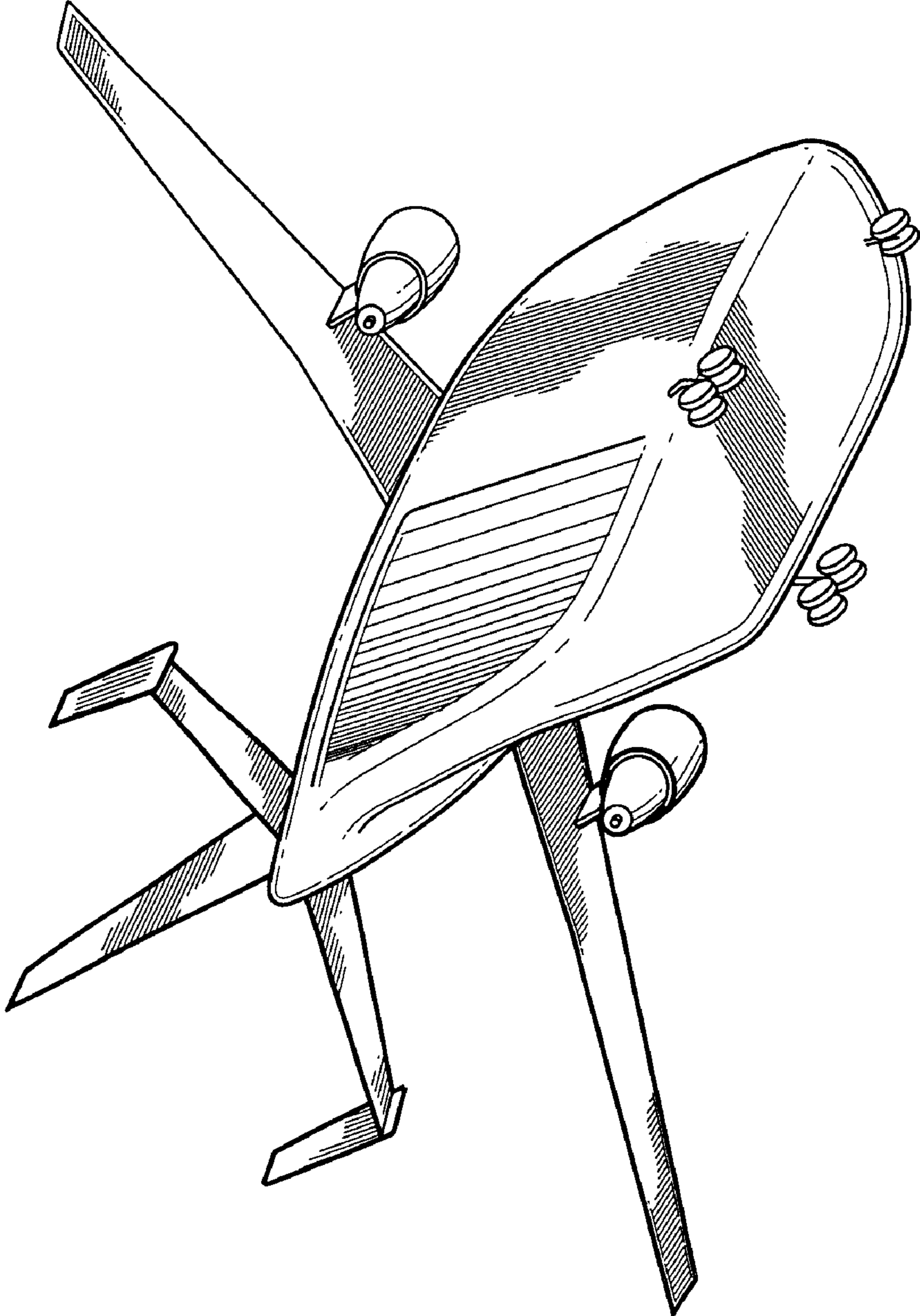

FIG. 3

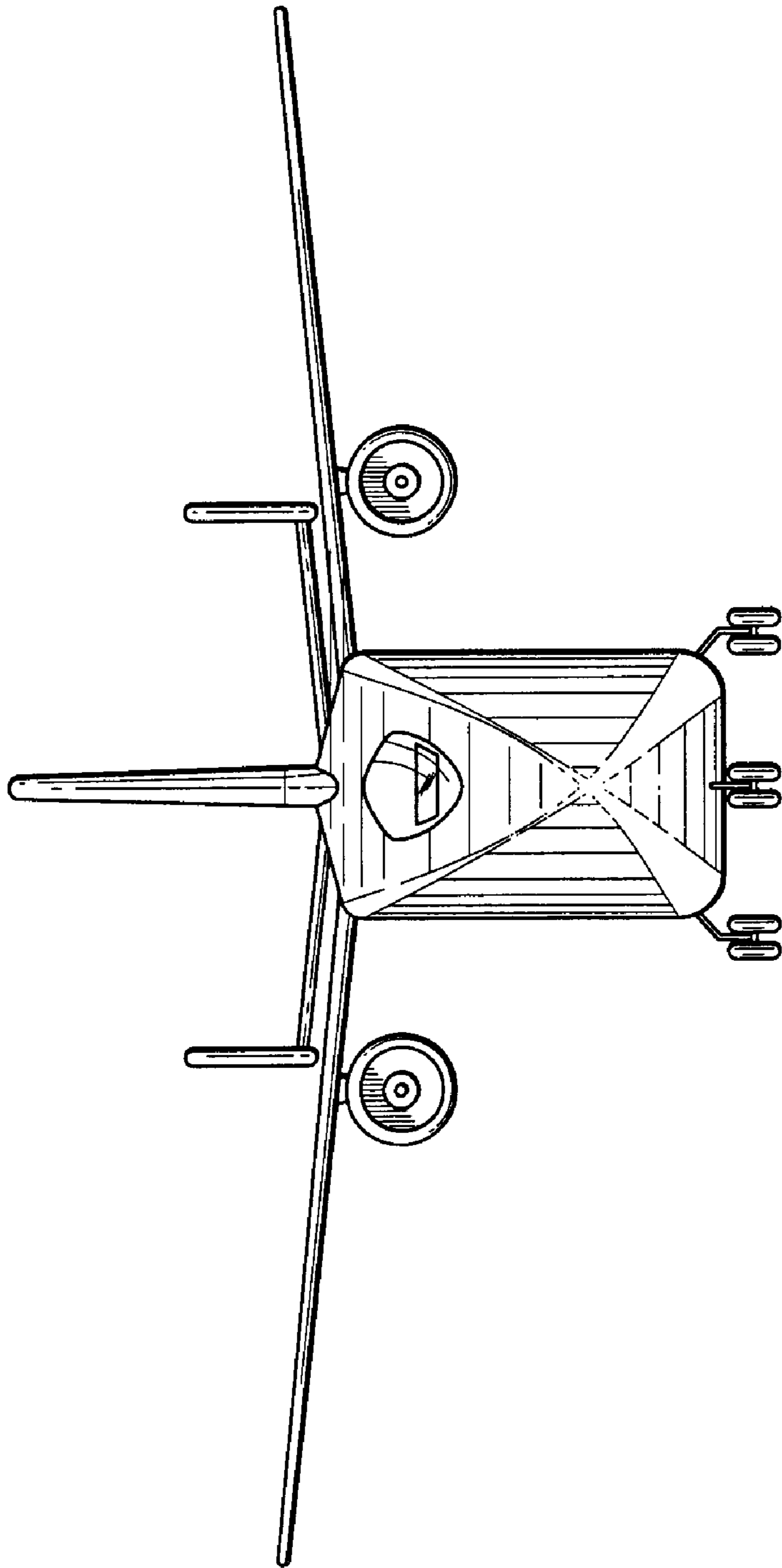

FIG.4

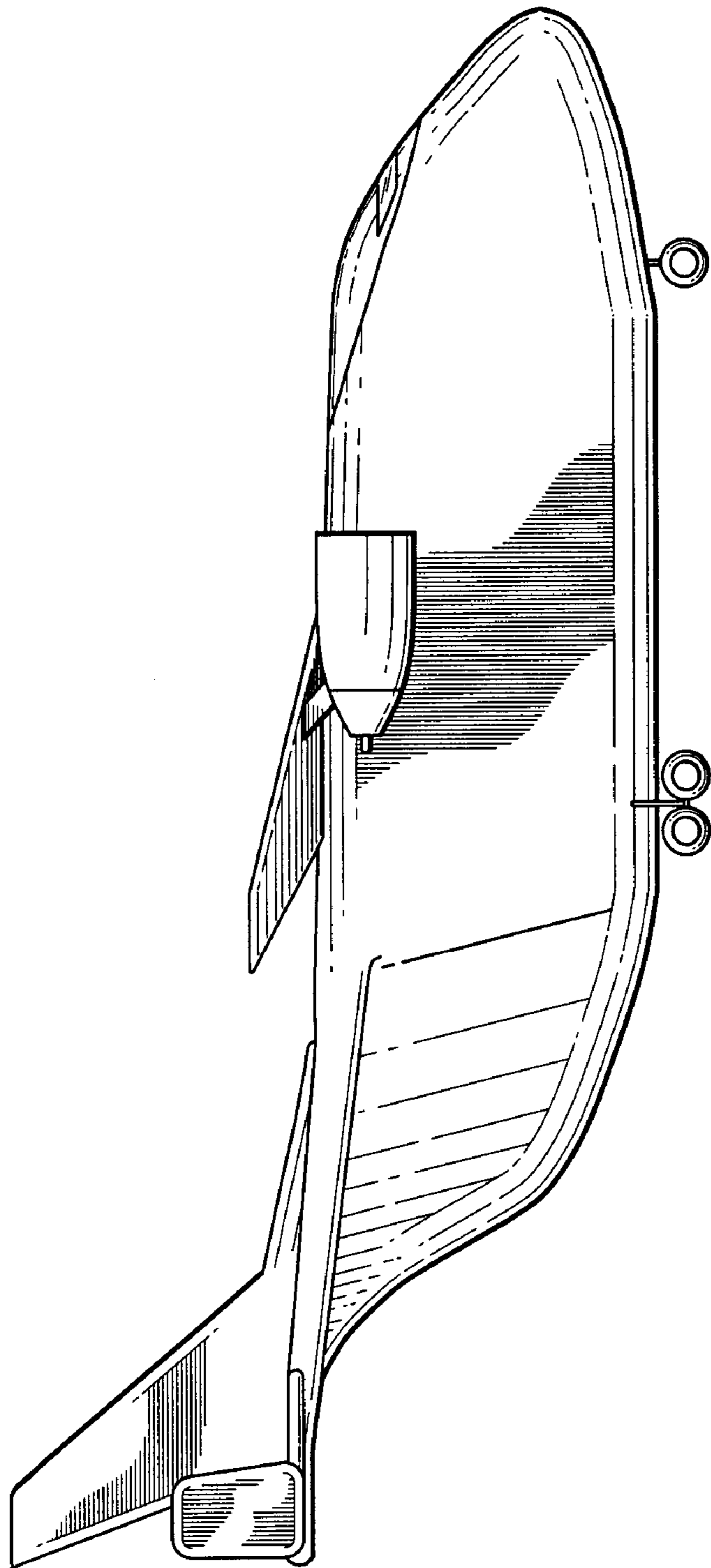

FIG. 5

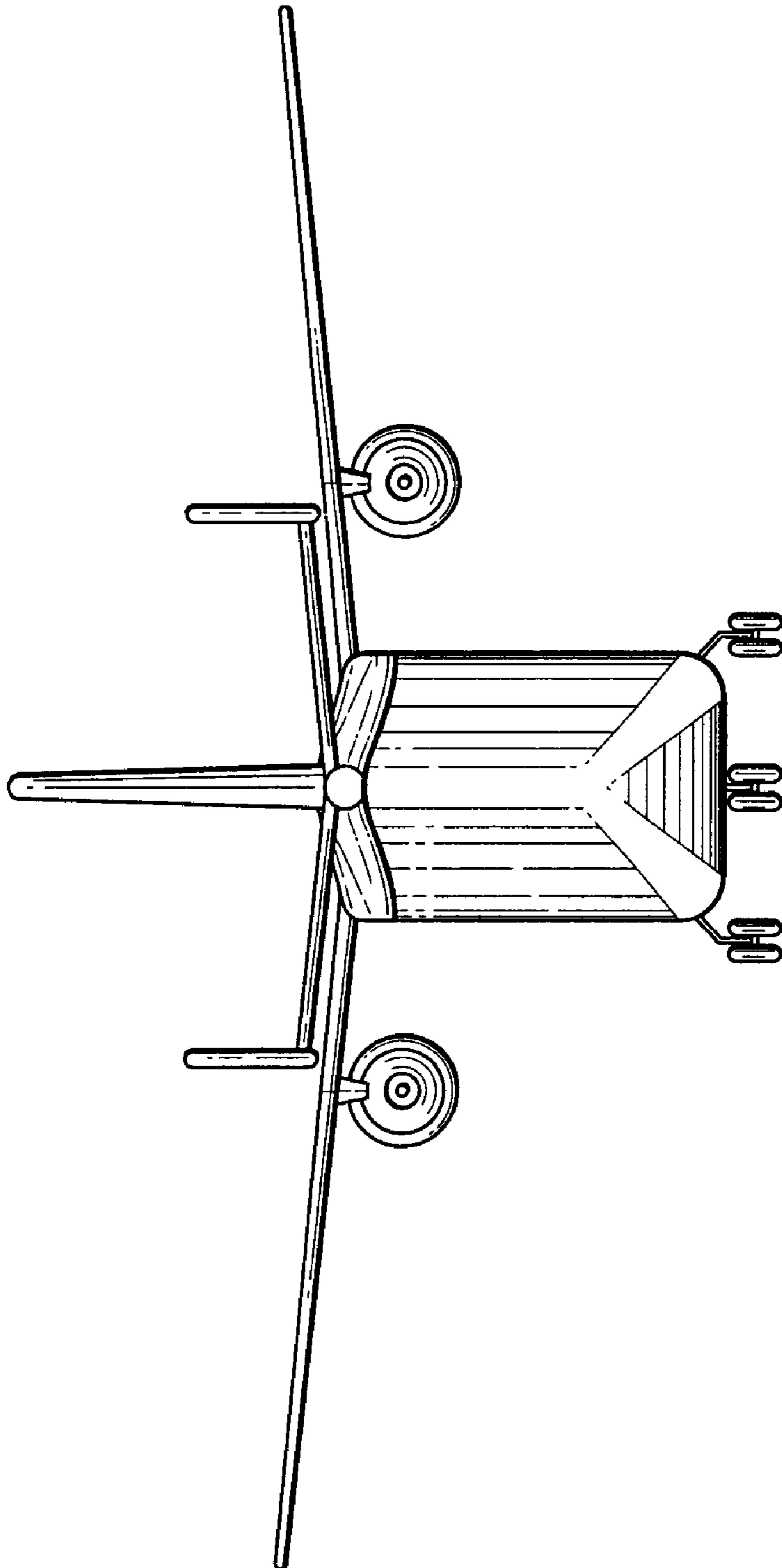

FIG. 6

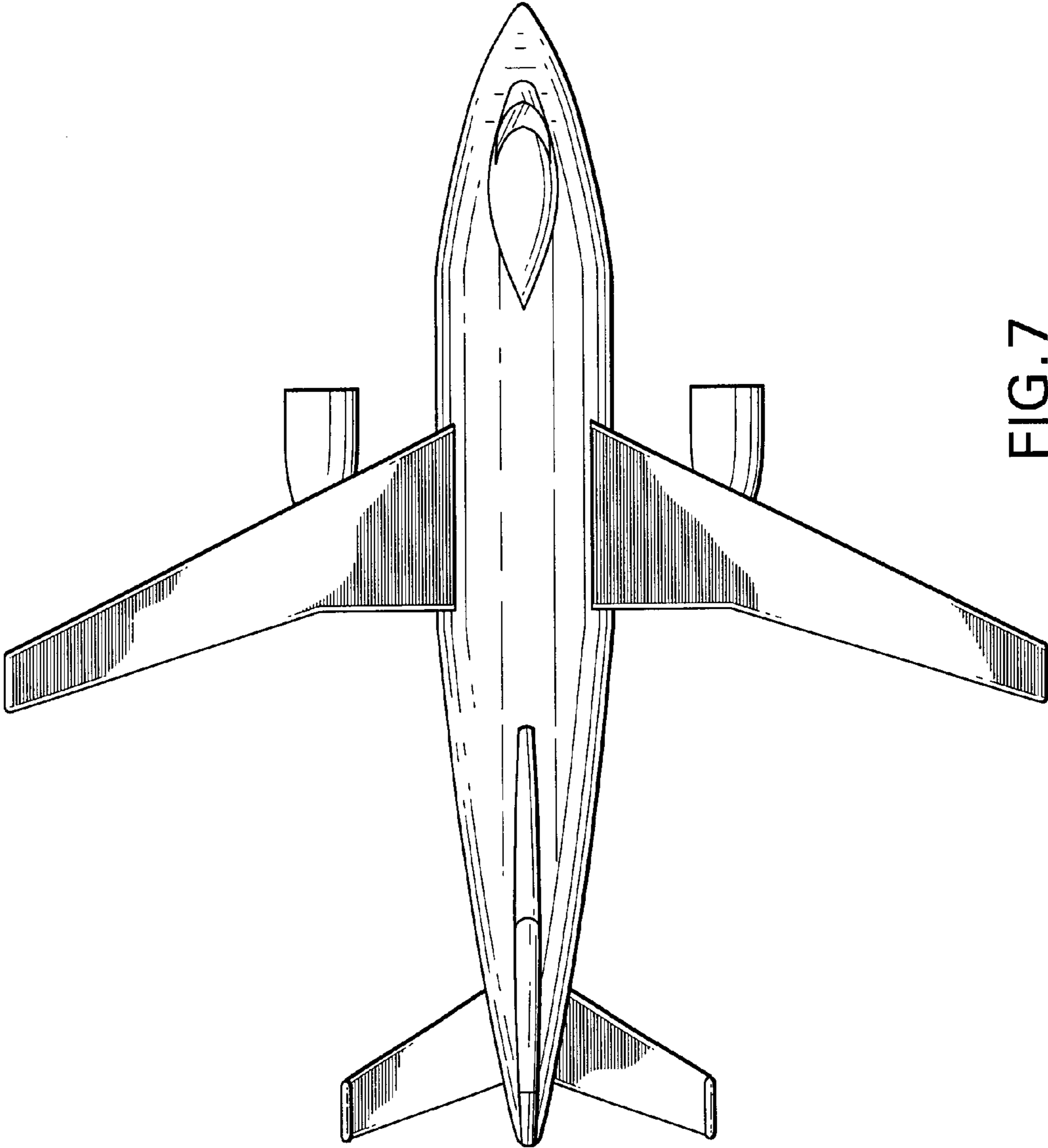

FIG. 7