



US00D530243S

(12) **United States Design Patent**
Lin

(10) **Patent No.:** **US D530,243 S**

(45) **Date of Patent:** **** Oct. 17, 2006**

(54) **MOTORCYCLE**

D503,908 S * 4/2005 Tomomatsu et al. D12/110

(75) Inventor: **Shui-Wang Lin**, Hsinchu County (TW)

* cited by examiner

(73) Assignee: **Sanyang Industry Co., Ltd.**, Hsinchu County (TW)

Primary Examiner—Alan P. Douglas

Assistant Examiner—Linda Brooks

(74) *Attorney, Agent, or Firm*—Quintero Law Office

(**) Term: **14 Years**

(21) Appl. No.: **29/244,773**

(22) Filed: **Dec. 13, 2005**

(30) **Foreign Application Priority Data**

Nov. 8, 2005 (TW) 94306757

(51) **LOC (8) Cl.** **12-11**

(52) **U.S. Cl.** **D12/110**

(58) **Field of Classification Search** D12/110;
180/219, 220, 225, 229

See application file for complete search history.

(56) **References Cited**

U.S. PATENT DOCUMENTS

D480,661 S * 10/2003 Kawawa et al. D12/110

(57) **CLAIM**

The ornamental design for a motorcycle, as shown and described.

DESCRIPTION

FIG. 1 is a perspective view thereof;
FIG. 2 is a front elevational view thereof;
FIG. 3 is a rear elevational view thereof;
FIG. 4 is a left side elevational view thereof;
FIG. 5 is a right side elevational view thereof;
FIG. 6 is a top plane view thereof; and,
FIG. 7 is a bottom plane view thereof.

1 Claim, 7 Drawing Sheets

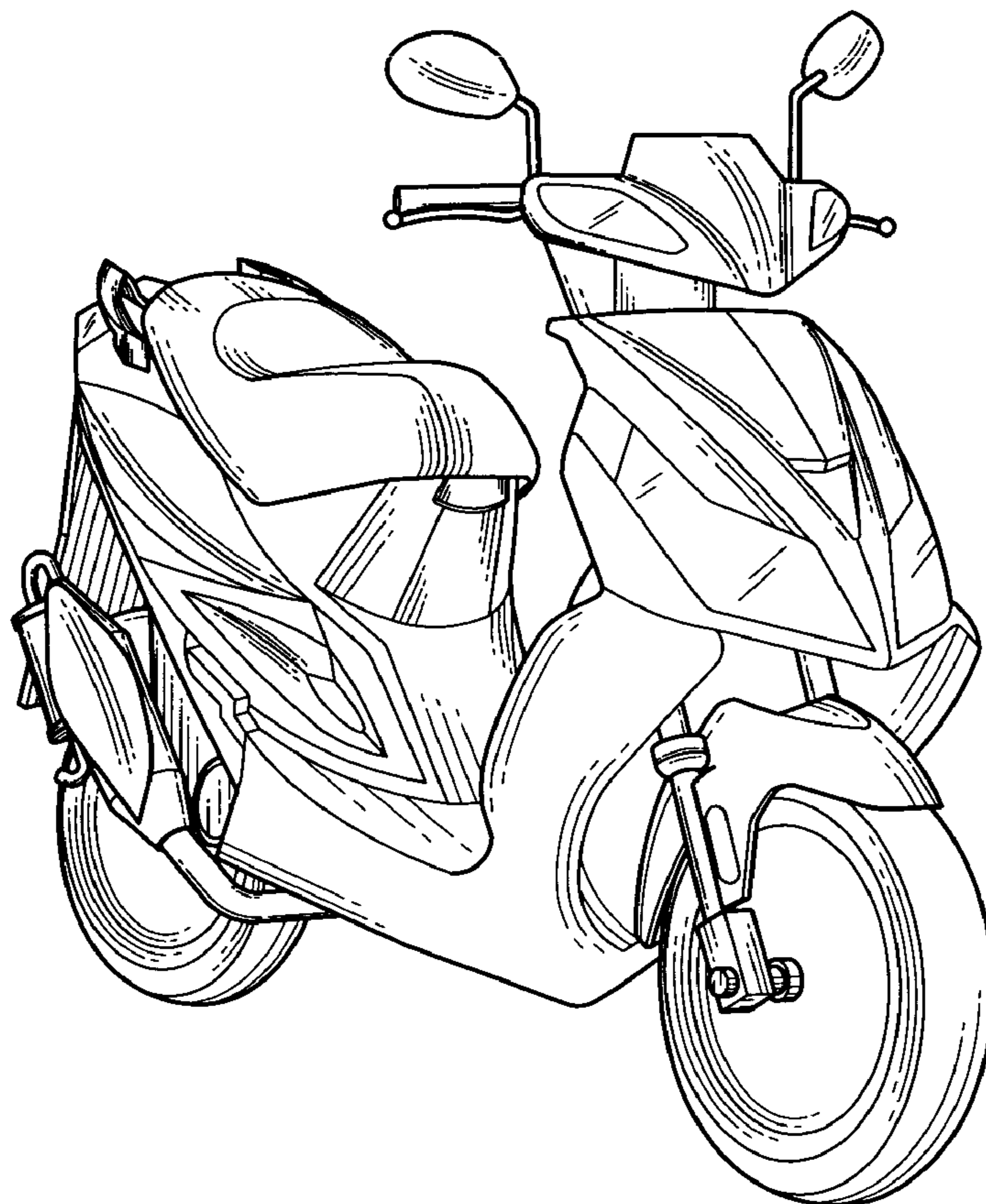

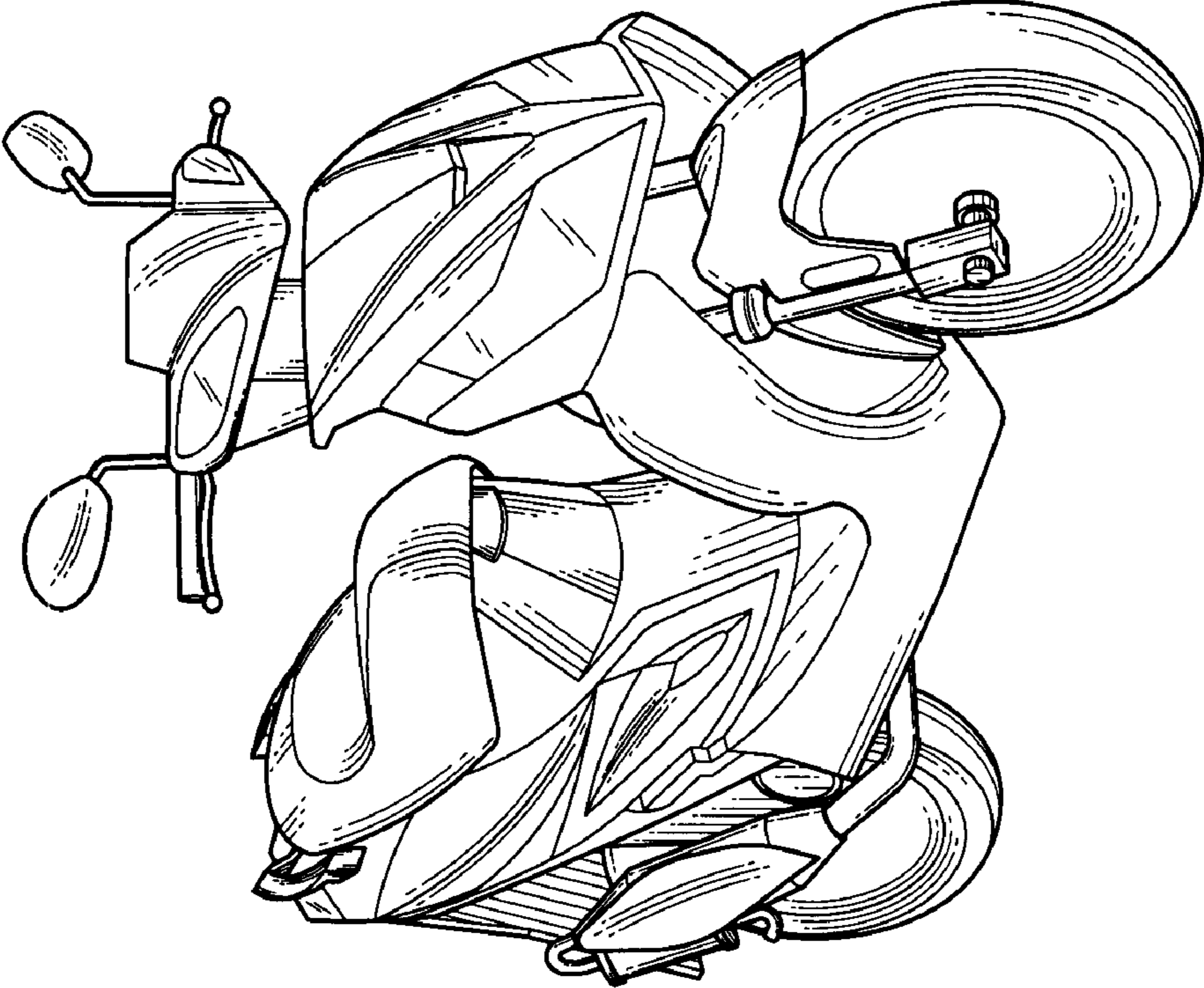

FIG. 1

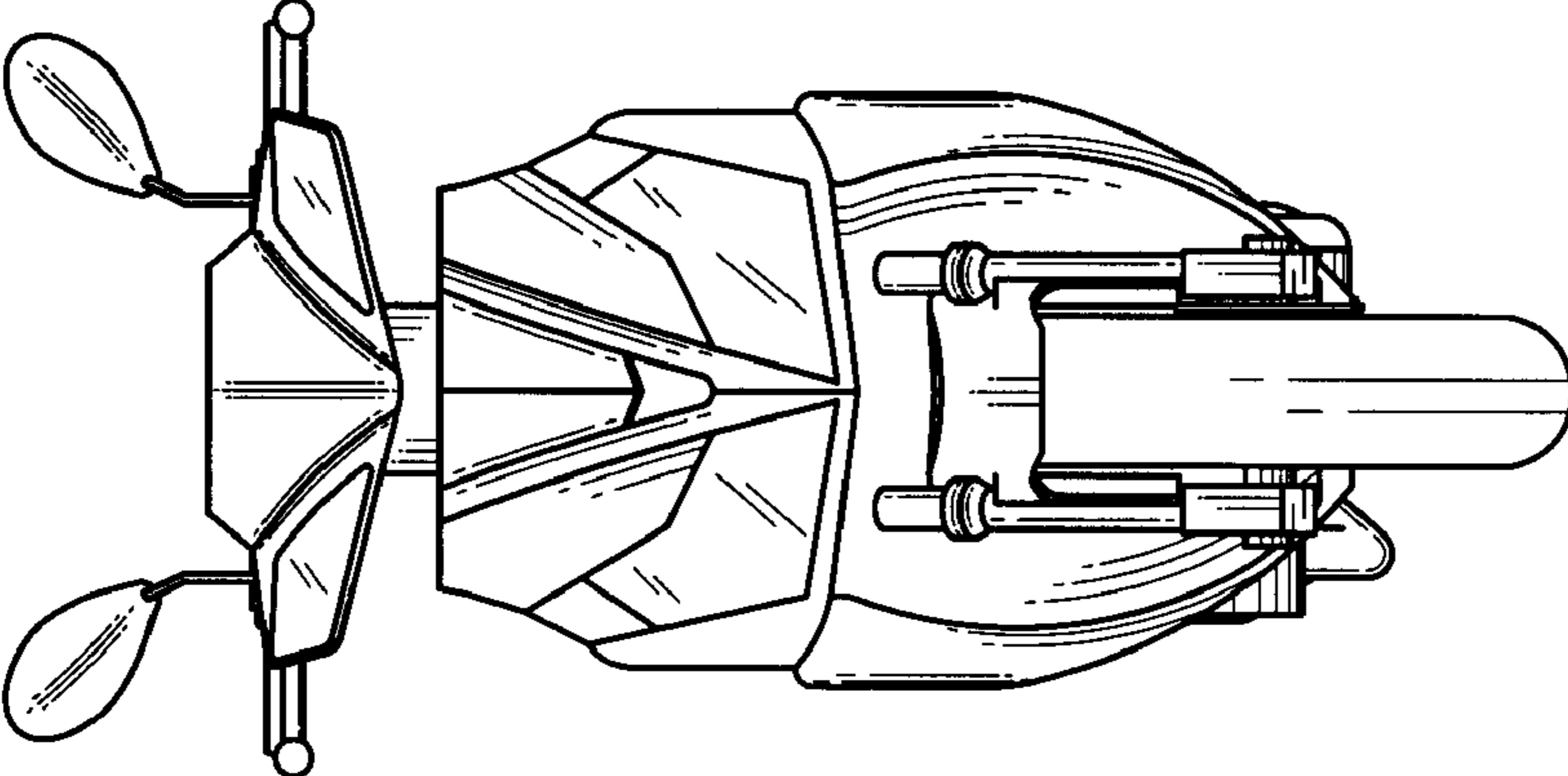

FIG. 2

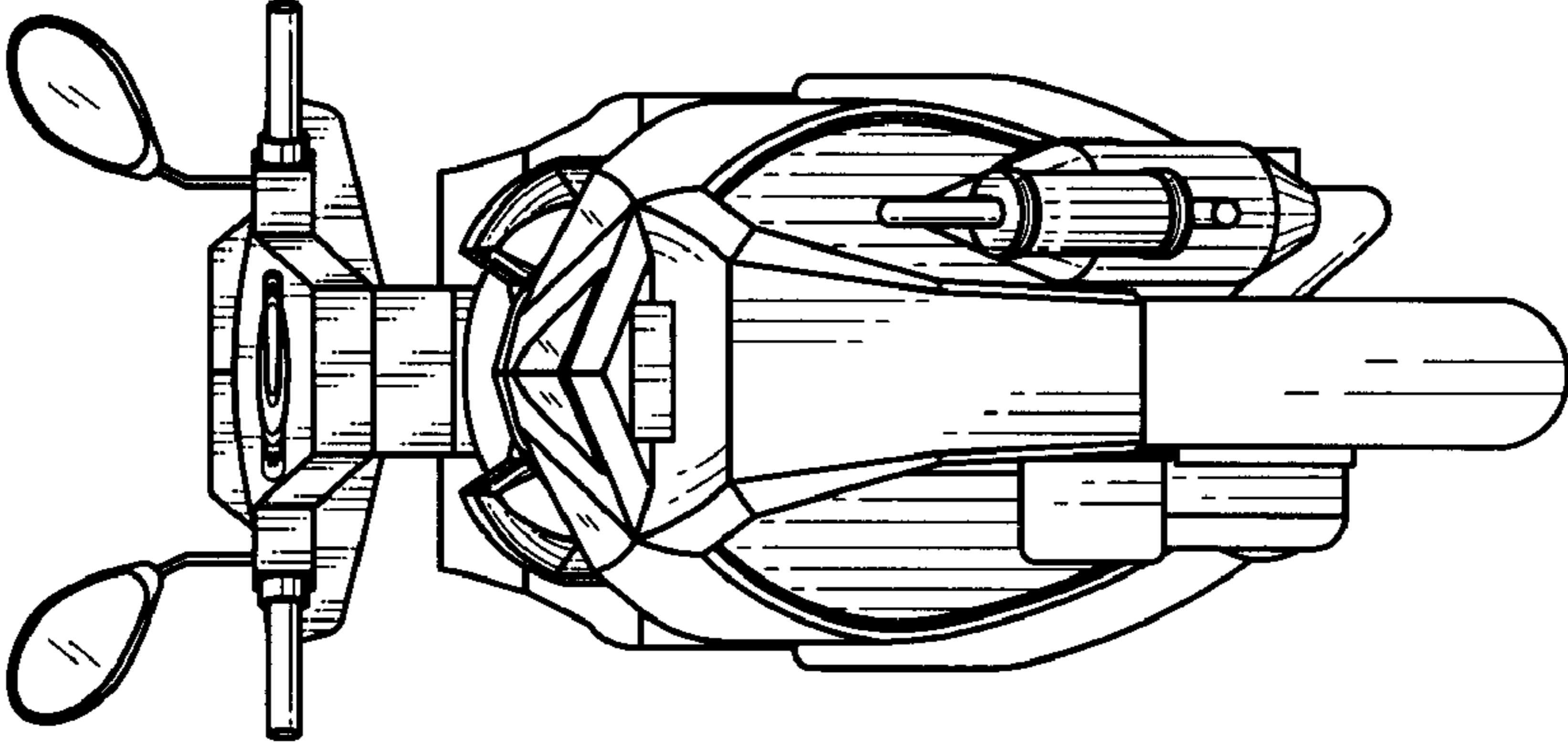

FIG. 3

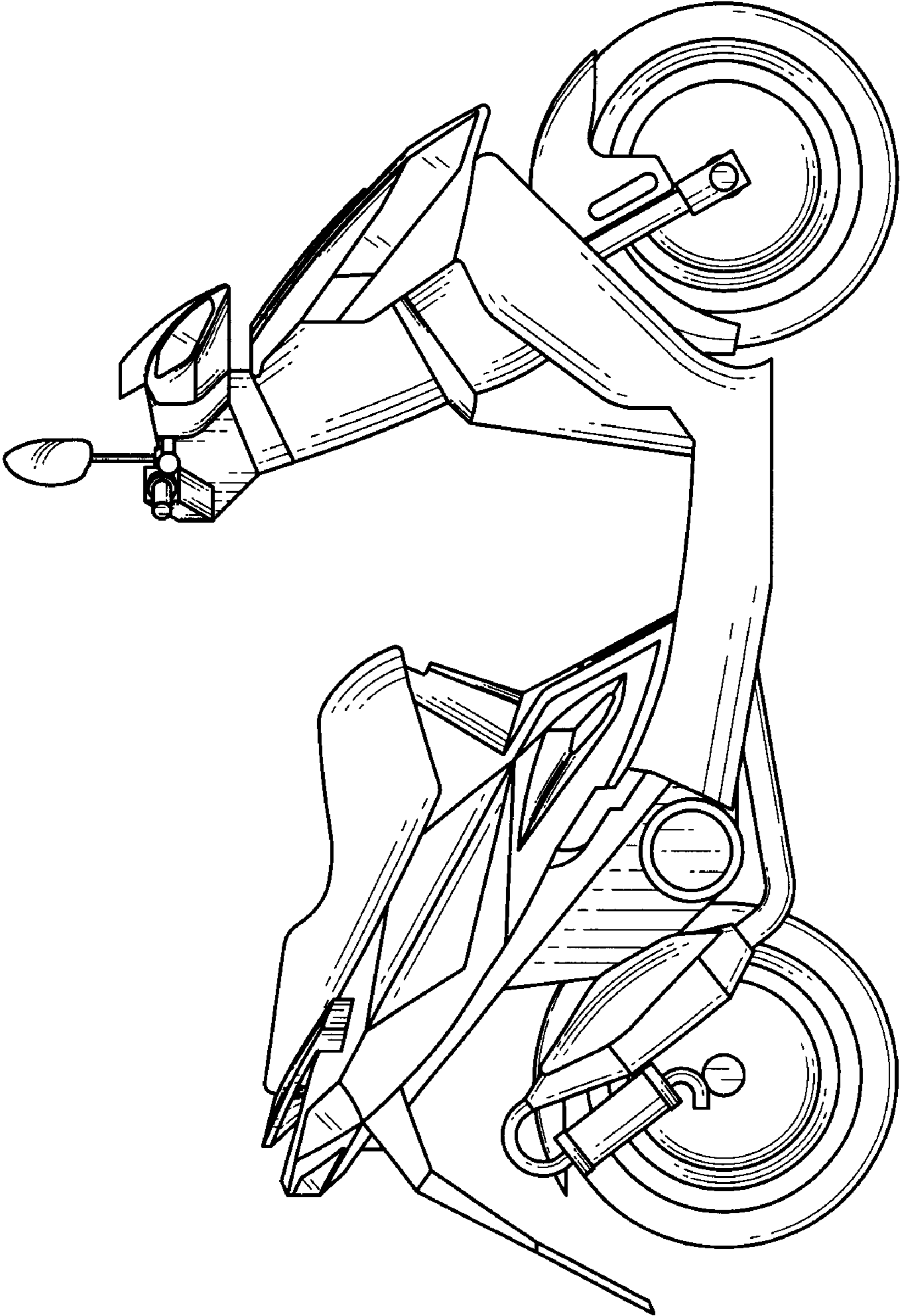

FIG. 4

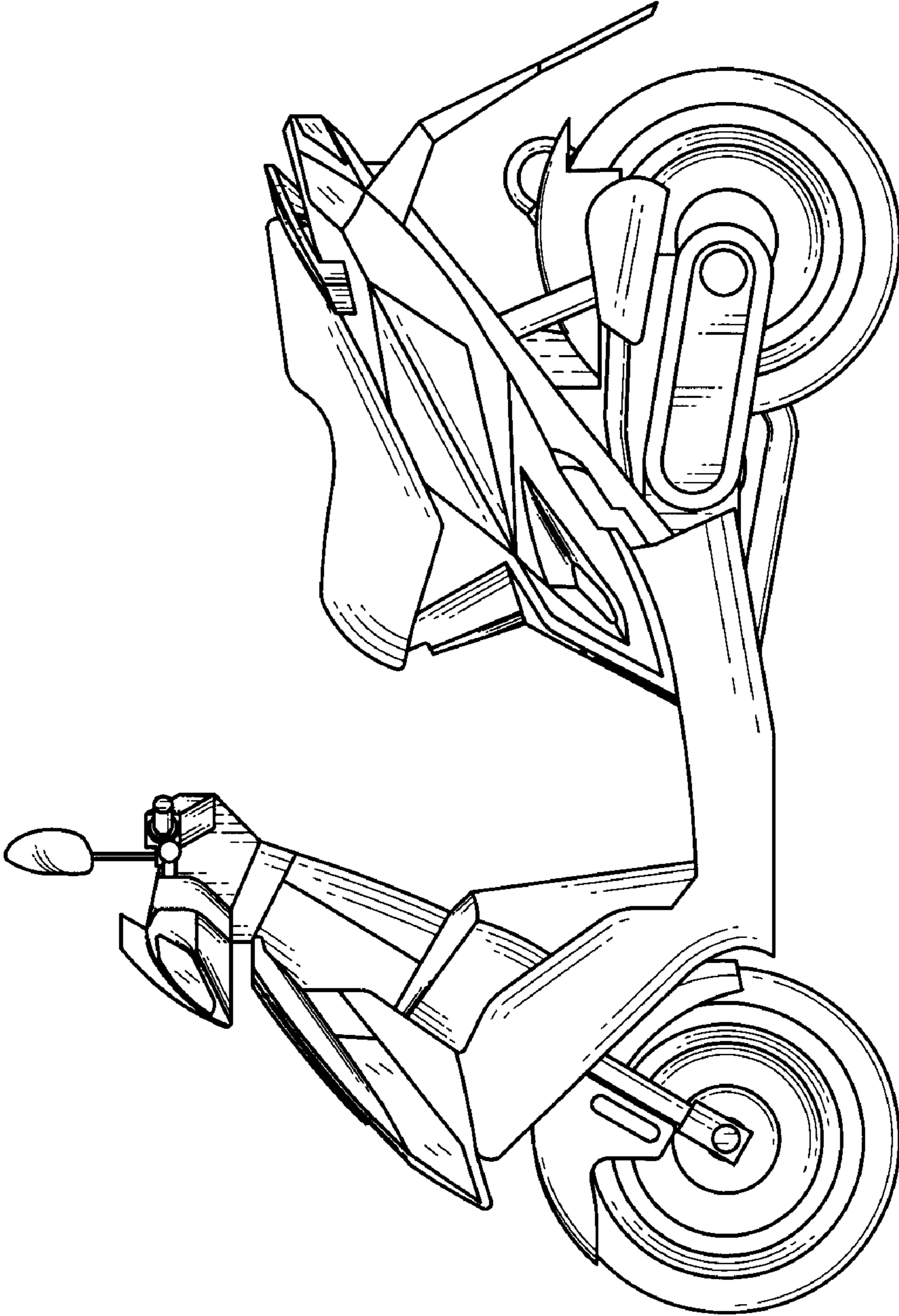

FIG. 5

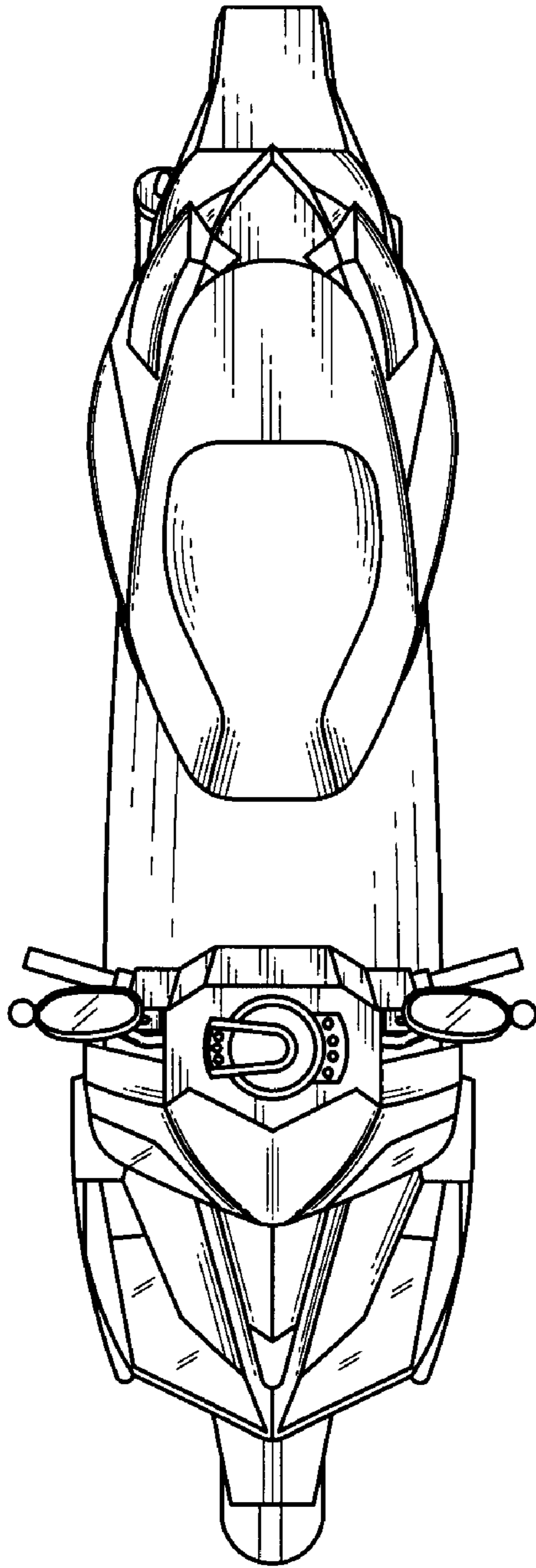

FIG. 6

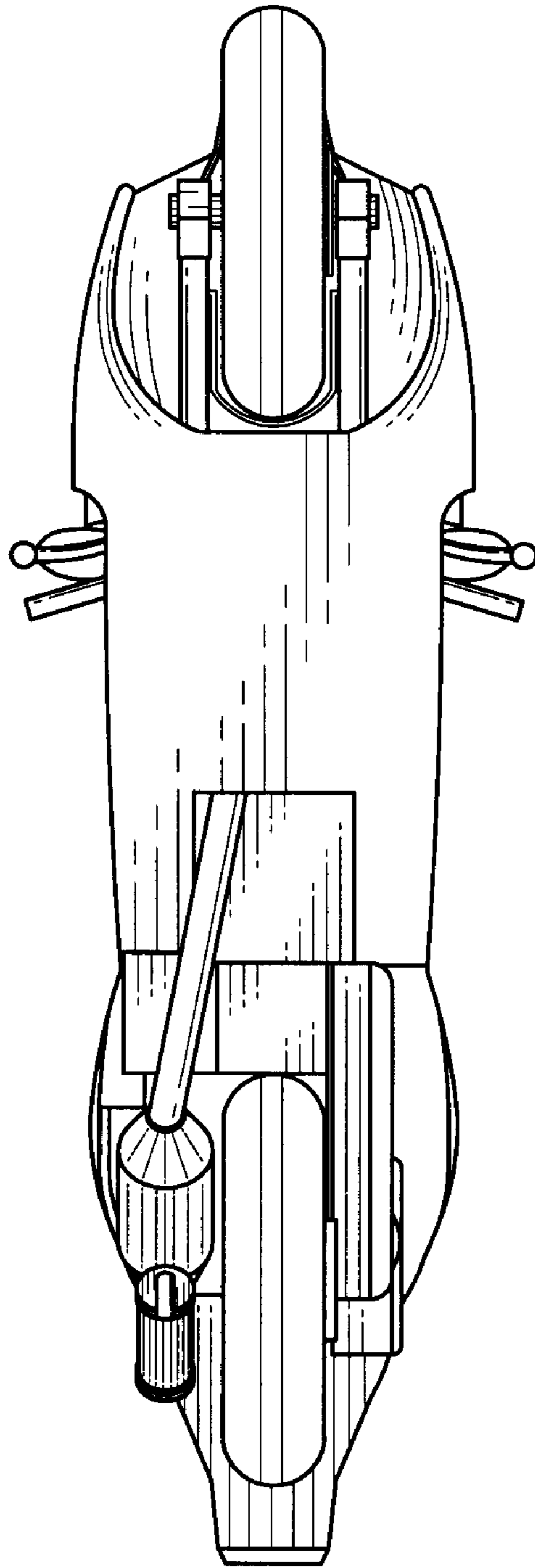

FIG. 7