

US00D529967S

(12) **United States Design Patent**
Bowen et al.

(10) **Patent No.:** **US D529,967 S**

(45) **Date of Patent:** **** Oct. 10, 2006**

- (54) **TOY VEHICLE AND PARTS THEREOF**
- (75) Inventors: **David Bowen**, Hermosa Beach, CA (US); **Paulo Kang**, Pasadena, CA (US)
- (73) Assignee: **Mattel, Inc.**, El Segundo, CA (US)
- (**) Term: **14 Years**
- (21) Appl. No.: **29/235,734**
- (22) Filed: **Aug. 4, 2005**

Related U.S. Application Data

- (63) Continuation-in-part of application No. 29/233,004, filed on Jun. 24, 2005, and a continuation-in-part of application No. 29/223,218, filed on Feb. 9, 2005.
- (51) **LOC (8) Cl.** **21-01**
- (52) **U.S. Cl.** **D21/533**
- (58) **Field of Classification Search** D21/533,
D21/398, 548, 563, 578-580, 498; 446/456-458,
446/436-437, 464-465, 442-443, 448-449,
446/409, 433, 462, 97, 175, 297, 71, 231,
446/288-289, 273, 294, 376, 90, 222, 85
See application file for complete search history.

D262,224 S	12/1981	Aoki	
4,310,987 A	1/1982	Chieffo	
4,386,787 A	6/1983	Maplethorpe et al.	
4,391,224 A	7/1983	Adler	
4,438,588 A	3/1984	Martin	
4,471,567 A	9/1984	Martin	
4,501,569 A	2/1985	Clark, Jr. et al.	
4,505,346 A	3/1985	Mueller	
4,541,814 A	9/1985	Martin	
4,568,306 A	2/1986	Martin	
4,599,077 A	7/1986	Vuillard	
4,601,675 A	7/1986	Robinson	
4,609,196 A	9/1986	Bozinovic	
4,666,420 A	5/1987	Nagano	
4,671,779 A	6/1987	Kurosawa	
4,674,585 A	6/1987	Barlow et al.	
D292,110 S	* 9/1987	Tamakoshi	D21/578
4,693,696 A	9/1987	Buck	
4,726,800 A	2/1988	Kobayashi	
4,773,889 A	9/1988	Rosenwinkel et al.	
4,892,503 A	1/1990	Kumazawa	
4,897,070 A	1/1990	Wagstaff	
4,927,401 A	5/1990	Sonesson	
5,041,051 A	8/1991	Sonesson	
5,131,882 A	7/1992	Kiyokane	
D336,935 S	* 6/1993	York et al.	D21/533
5,439,408 A	8/1995	Wilkinson	
5,487,692 A	1/1996	Mowrer et al.	
5,533,921 A	7/1996	Wilkinson	
5,618,219 A	4/1997	Simone et al.	
5,667,420 A	9/1997	Menow et al.	
5,692,946 A	12/1997	Ku	
5,769,441 A	6/1998	Namngani	
5,797,815 A	8/1998	Goldman et al.	
D399,890 S	10/1998	Esterle et al.	
5,871,386 A	2/1999	Bart et al.	
5,919,075 A	7/1999	George et al.	
D414,517 S	* 9/1999	Norris	D21/660
D420,403 S	2/2000	Bart	
6,024,627 A	2/2000	Tilbor et al.	
D423,602 S	4/2000	Yamazaki	
6,066,026 A	5/2000	Bart et al.	
6,095,890 A	8/2000	George et al.	
6,129,607 A	10/2000	Hoeting et al.	
D441,407 S	5/2001	Goldman	
6,227,934 B1	5/2001	Isaksson et al.	
D450,788 S	* 11/2001	Kawasaki	D21/578
6,439,948 B1	8/2002	Ostendorff et al.	
6,458,008 B1	10/2002	Hyneman	

(56) **References Cited**

U.S. PATENT DOCUMENTS

2,104,636 A	1/1938	Burcham
2,372,043 A	3/1945	Aghnides
D145,050 S	6/1946	Arnold
2,949,697 A	8/1960	Licitis et al.
3,312,013 A	4/1967	Graves
3,327,796 A	6/1967	Hanmer
3,500,579 A	3/1970	Bryer
3,555,725 A	1/1971	Orfei et al.
3,667,156 A	6/1972	Tomiyama et al.
3,722,134 A	3/1973	Merrill et al.
3,733,739 A	5/1973	Terzian
3,746,117 A	7/1973	Alred
3,798,835 A	3/1974	McKeehan
3,893,707 A	7/1975	Samsel
4,057,929 A	11/1977	Ogawa
4,300,308 A	11/1981	Ikeda

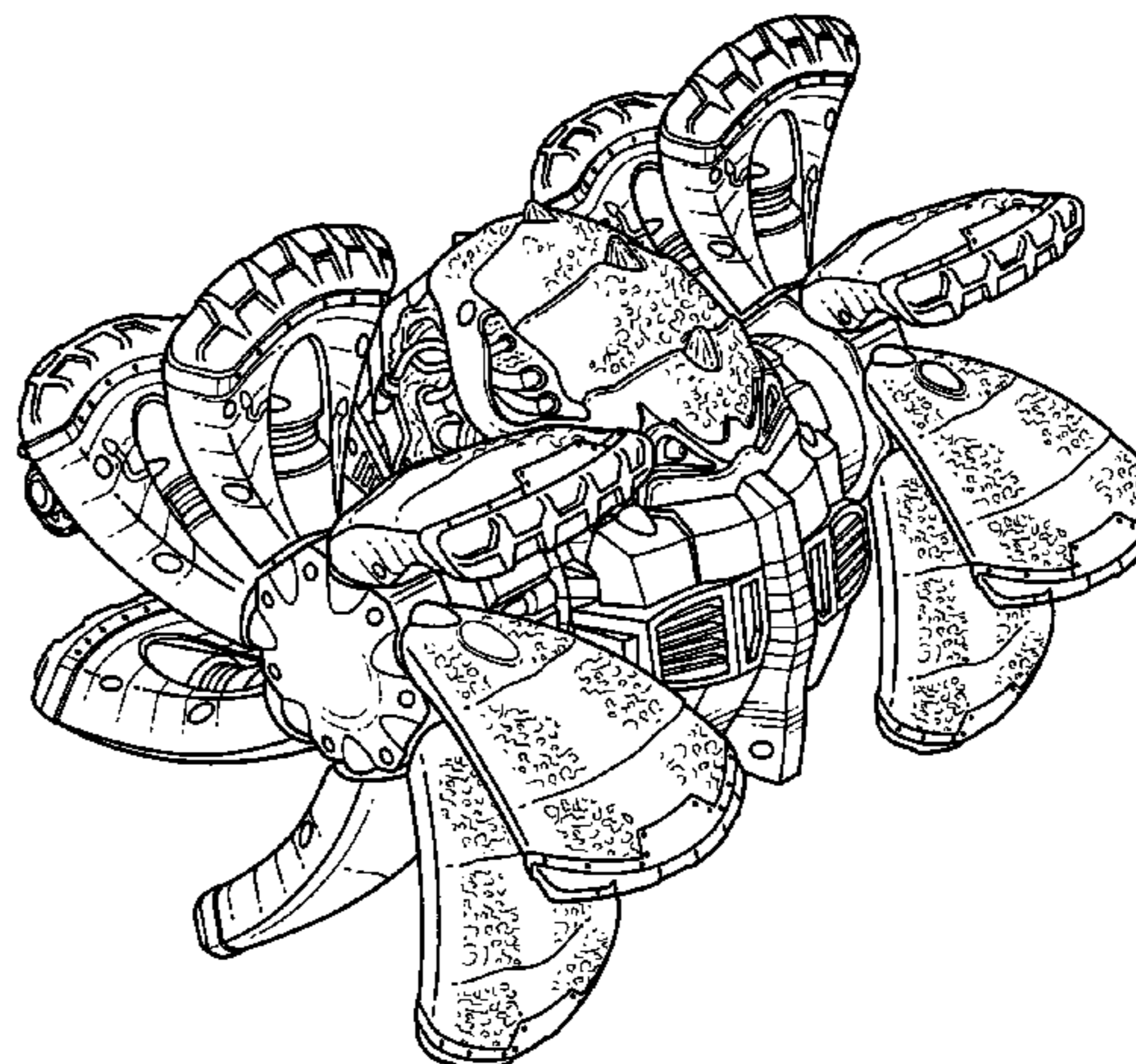
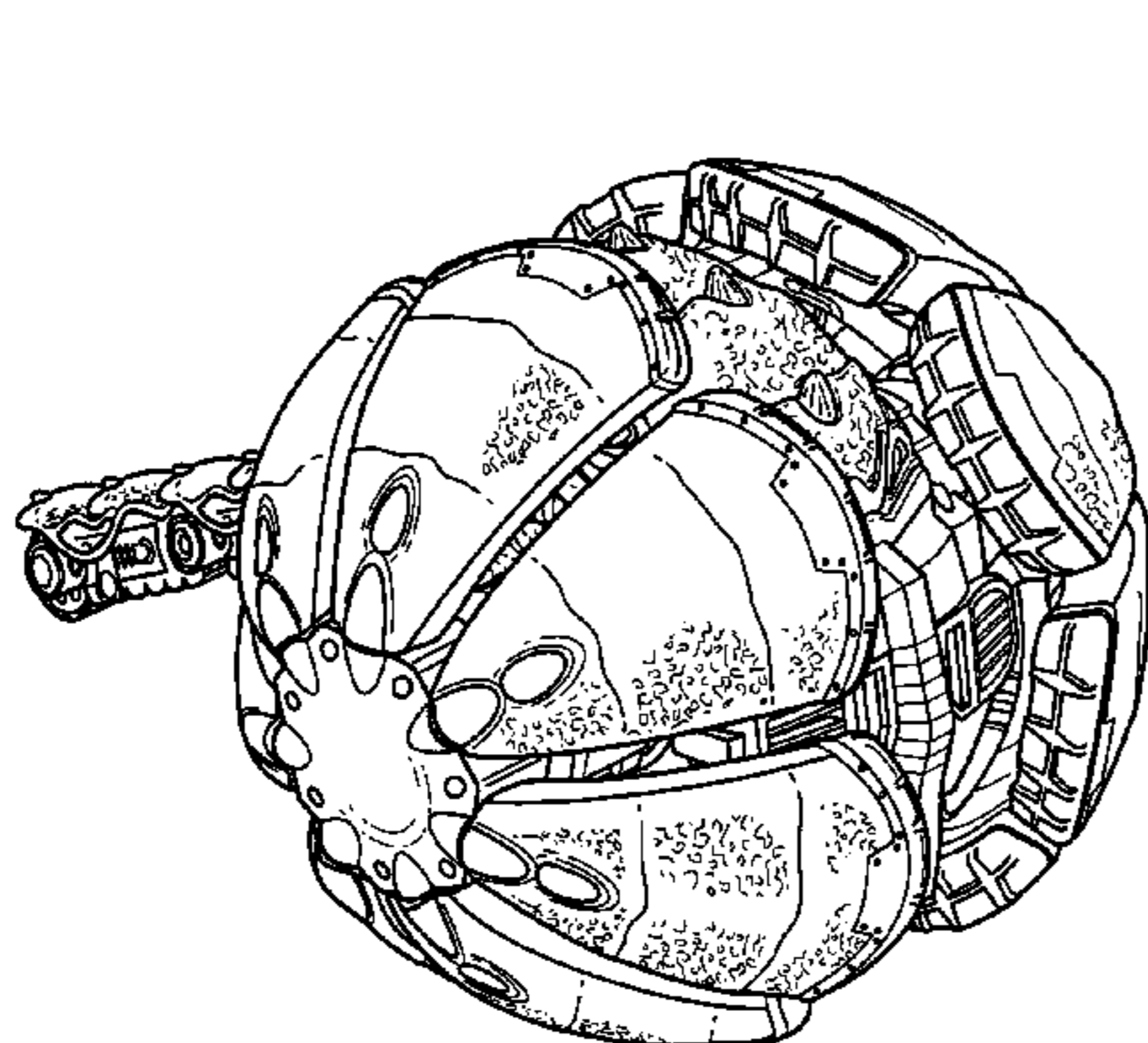

6,461,218	B1	10/2002	Mullaney et al.
6,475,059	B1	11/2002	Lee
6,502,657	B1	1/2003	Kerrebrock et al.
6,540,583	B1	4/2003	Hoeting et al.
6,648,722	B1	11/2003	Lynders et al.
6,752,684	B1	6/2004	Lee
6,764,374	B1	7/2004	Tilbor et al.
D504,748	S	5/2005	Jager

FOREIGN PATENT DOCUMENTS

DE	88 03 308.2	U1	6/1988
FR	2 539 904	A1	7/1984
GB	1 282 441	A	10/1972
JP	59-167584	U	11/1984
JP	61-139288	U	8/1986

OTHER PUBLICATIONS

MATTEL, *Mattel* 2003 Catalogue, 2 pages (2003).

* cited by examiner

Primary Examiner—Raphael Barkai
(74) Attorney, Agent, or Firm—Akin Gump Strauss Hauer & Feld, LLP

(57) **CLAIM**

The ornamental design for toy vehicle and parts thereof, as shown and described.

DESCRIPTION

FIG. 1 is a perspective view of a first configuration toy vehicle in accordance with our new design;
 FIG. 2 is a “front” elevation view thereof;
 FIG. 3 is a “rear” elevation view thereof;
 FIG. 4 is a “right” side elevation view thereof, the left side being a mirror image;
 FIG. 5 is a “top” plan view thereof;
 FIG. 6 is a “bottom” plan view thereof;
 FIG. 7 is a perspective view of a second configuration toy vehicle in accordance with our new design;
 FIG. 8 is a “front” elevation view thereof;
 FIG. 9 is a “rear” elevation view thereof;
 FIG. 10 is a “right” side elevation view thereof, the left side being a mirror image;
 FIG. 11 is a “top” plan view thereof;
 FIG. 12 is a “bottom” plan view thereof;
 FIG. 13 is a perspective view of a third configuration toy vehicle in accordance with our new design;

FIG. 14 is a “front” elevation view thereof;
 FIG. 15 is a “rear” elevation view thereof;
 FIG. 16 is a “right” side elevation view thereof, the left side being a mirror image;
 FIG. 17 is a “top” plan view thereof;
 FIG. 18 is a “bottom” plan view thereof;
 FIG. 19 is a perspective view of a fourth configuration toy vehicle in accordance with our new design;
 FIG. 20 is a “front” elevation view thereof;
 FIG. 21 is a “rear” elevation view thereof;
 FIG. 22 is a “right” side elevation view thereof, the left side being a mirror image;
 FIG. 23 is a “top” plan view thereof; and
 FIG. 24 is a “bottom” plan view thereof.
 FIG. 25 is a perspective view of a fifth configuration toy vehicle in accordance with our new design;
 FIG. 26 is a “front” elevation view thereof;
 FIG. 27 is a “rear” elevation view thereof;
 FIG. 28 is a “right” side elevation view thereof;
 FIG. 29 is a left side elevation view thereof;
 FIG. 30 is a “top” plan view thereof;
 FIG. 31 is a “bottom” plan view thereof;
 FIG. 32 is a perspective view of a sixth configuration toy vehicle in accordance with our new design;
 FIG. 33 is a “front” elevation view thereof;
 FIG. 34 is a “rear” elevation view thereof;
 FIG. 35 is a “right” side elevation view thereof, the left side view being a mirror image thereof;
 FIG. 36 is a “top” plan view thereof; and,
 FIG. 37 is a “bottom” plan view thereof.
 The “vaness” forming the two “wheels” of the fifth configuration vehicle (FIGS. 25–31) could be reversed 180 degrees from the directions depicted in FIGS. 25–31 to provide a seventh configuration vehicle, the views of which would be mirror images of FIGS. 25–31. Any combination of the configurations 1–4 can be provided in one vehicle by making the vanes forming wheels of the vehicle and/or the “tail” extending “rearward” from the chassis appropriately movable. In the same way, any combination of the vehicle configurations 1, 3, 4 and 5 can be provided in one vehicle as can any combination of the vehicle configurations 1, 3, 4 and 6 and any combination of vehicle configurations 1, 3, 4, and 7.

1 Claim, 37 Drawing Sheets

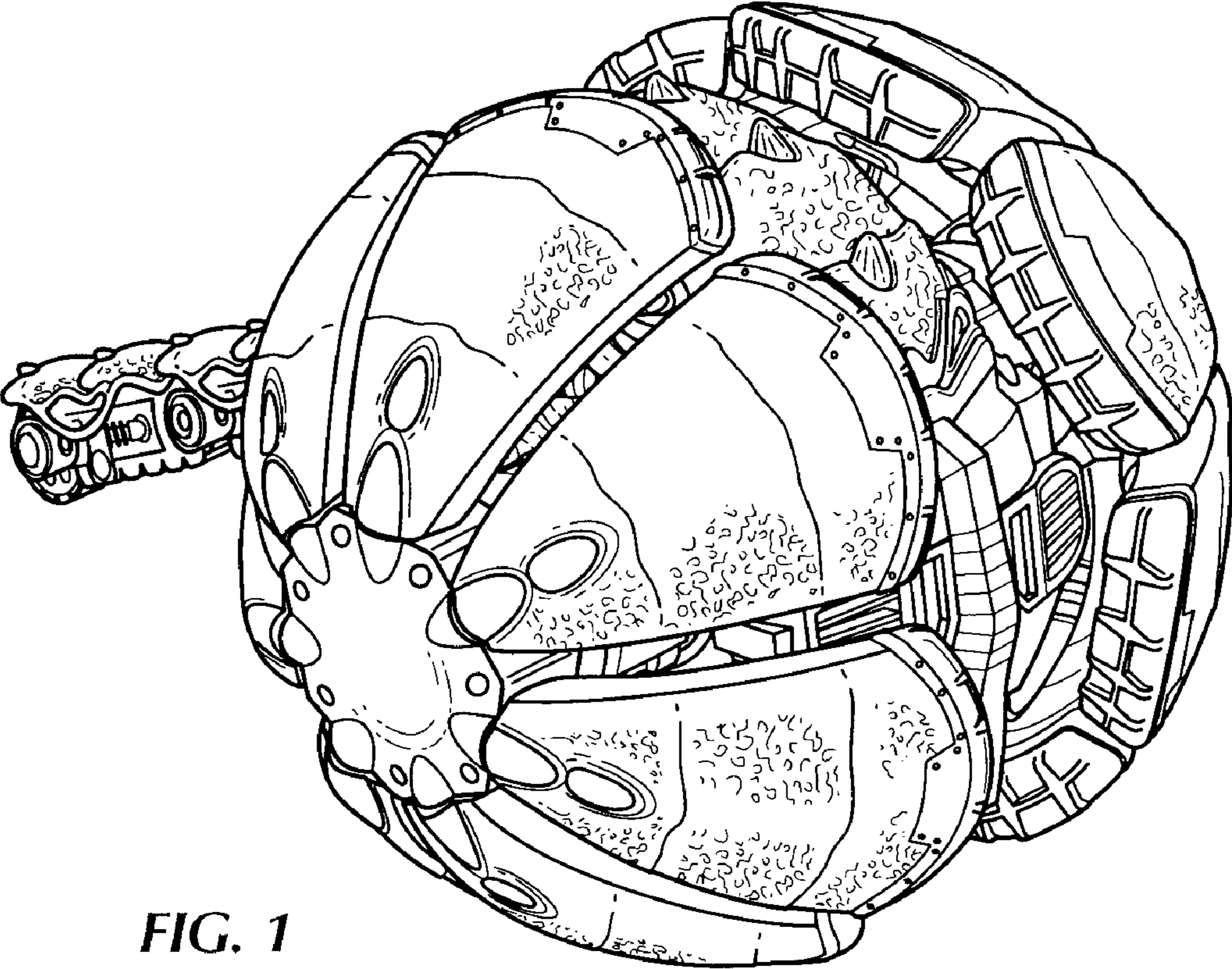

FIG. 1

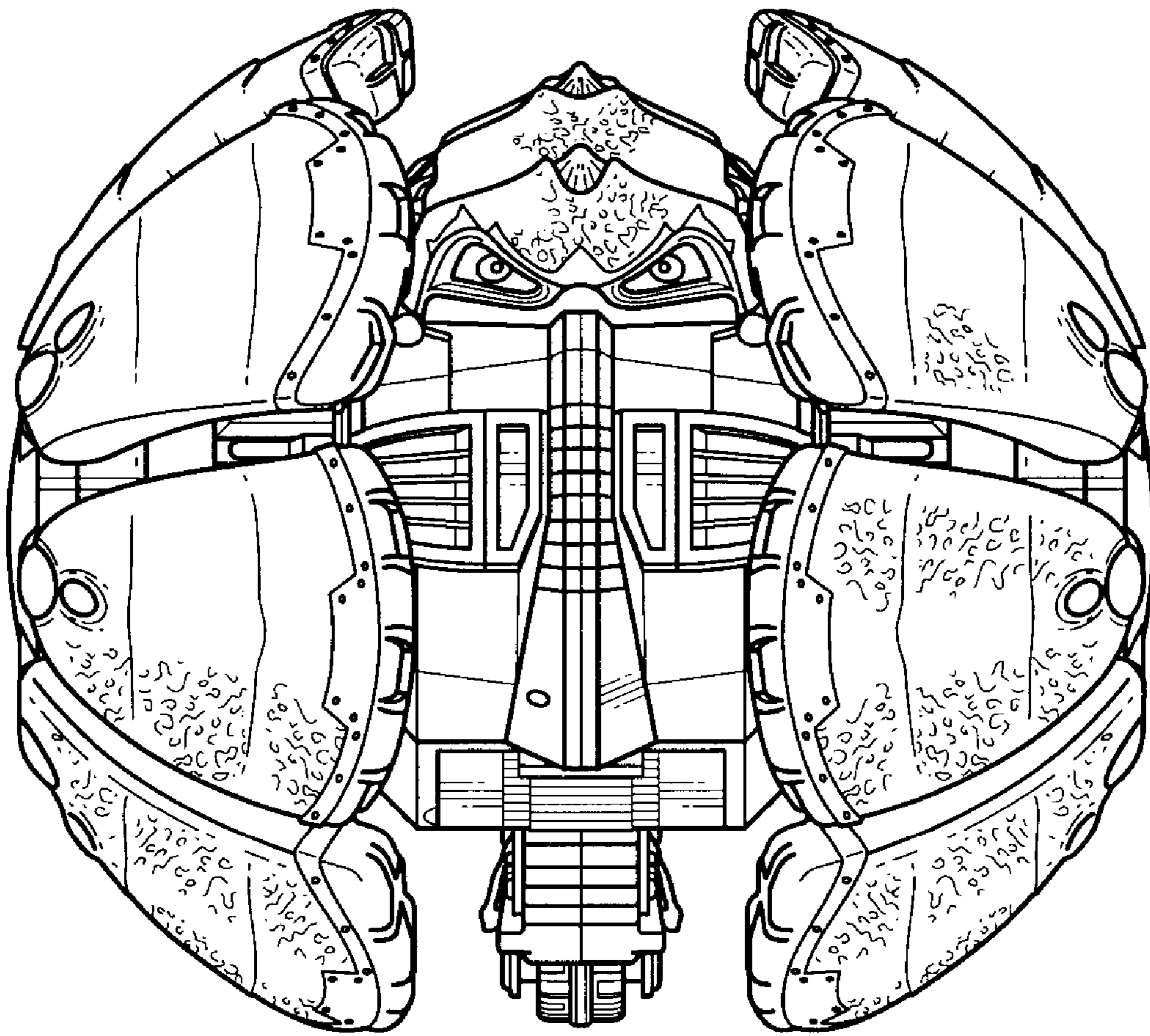

FIG. 2

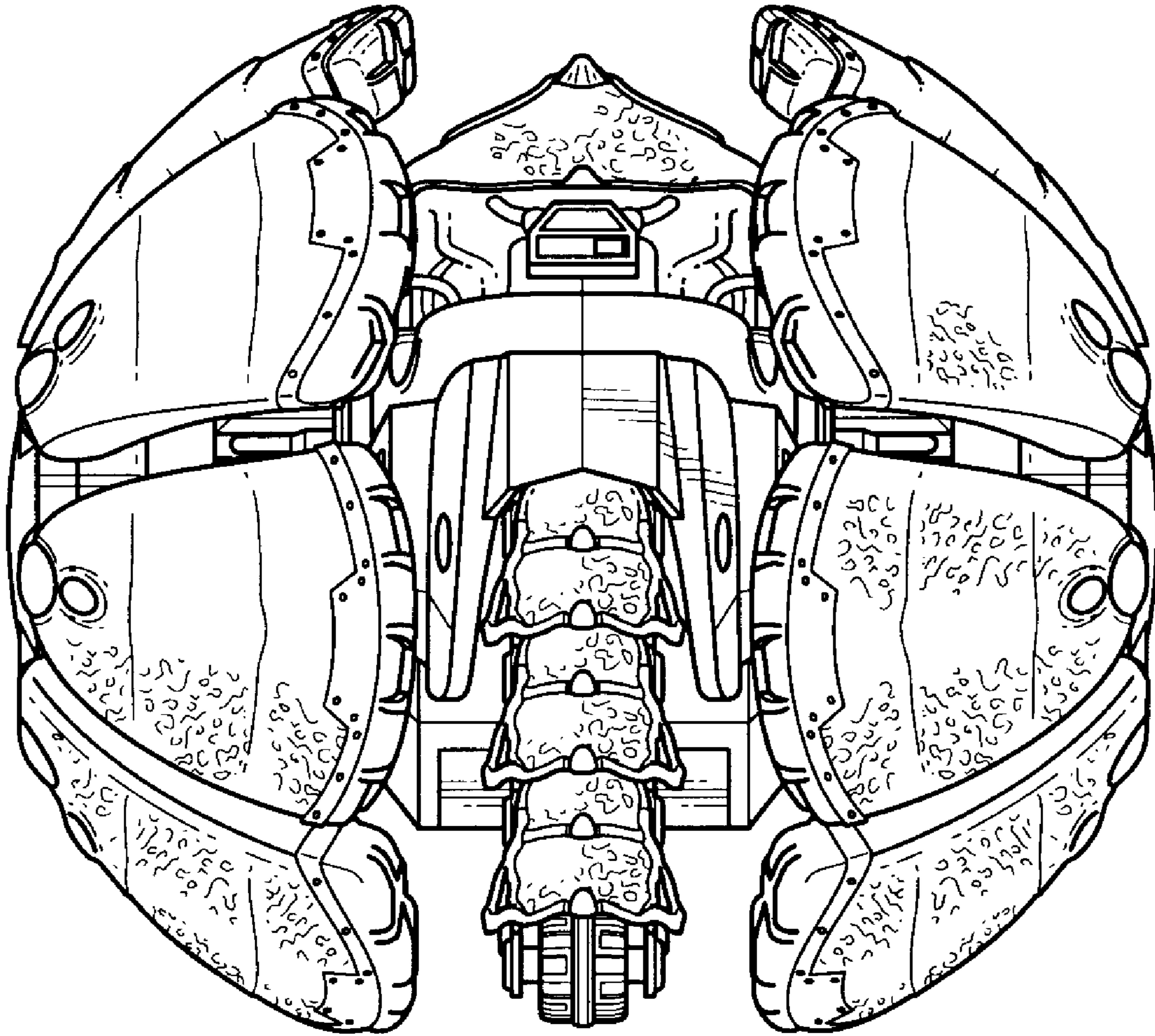

FIG. 3

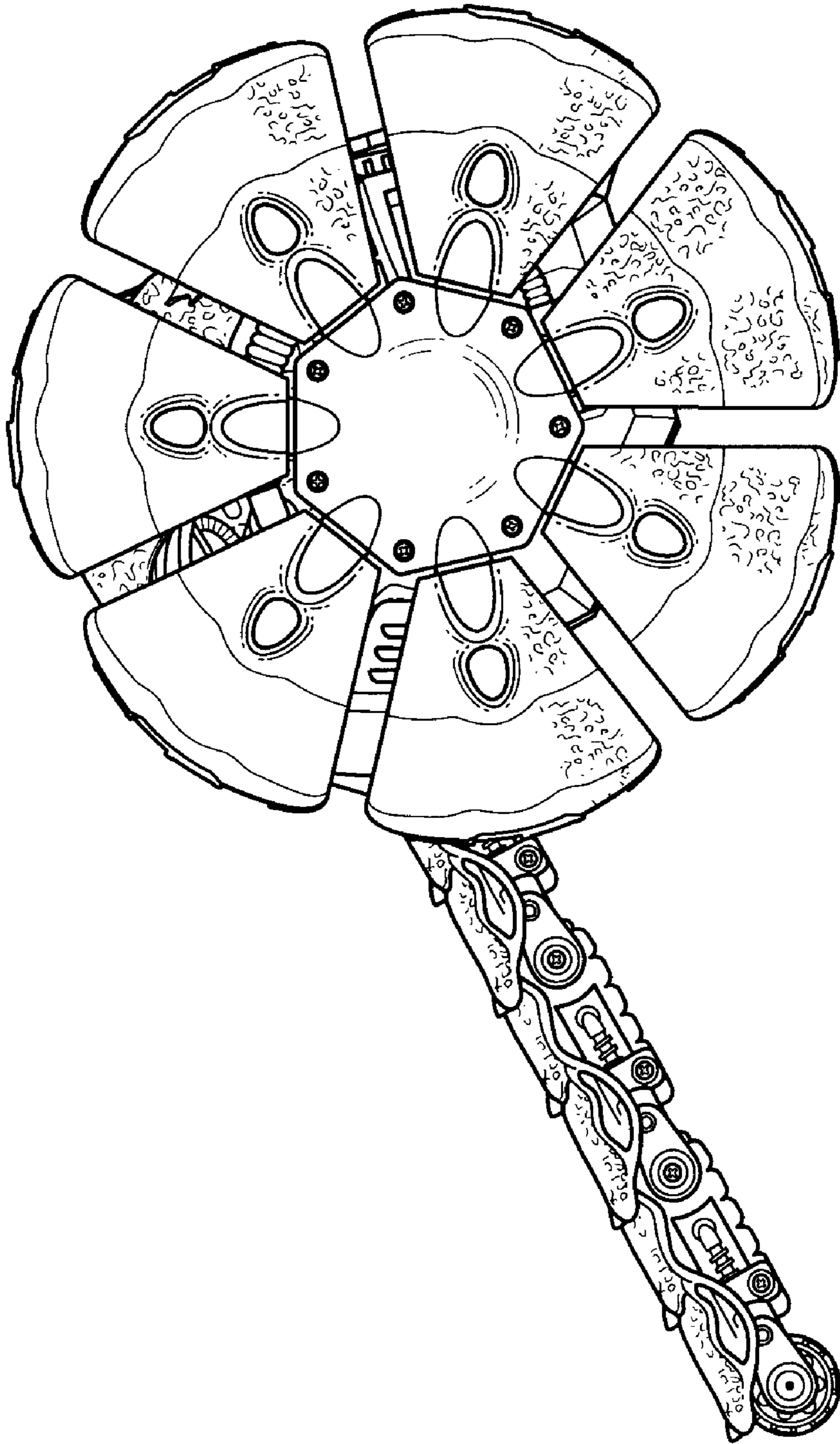

FIG. 4

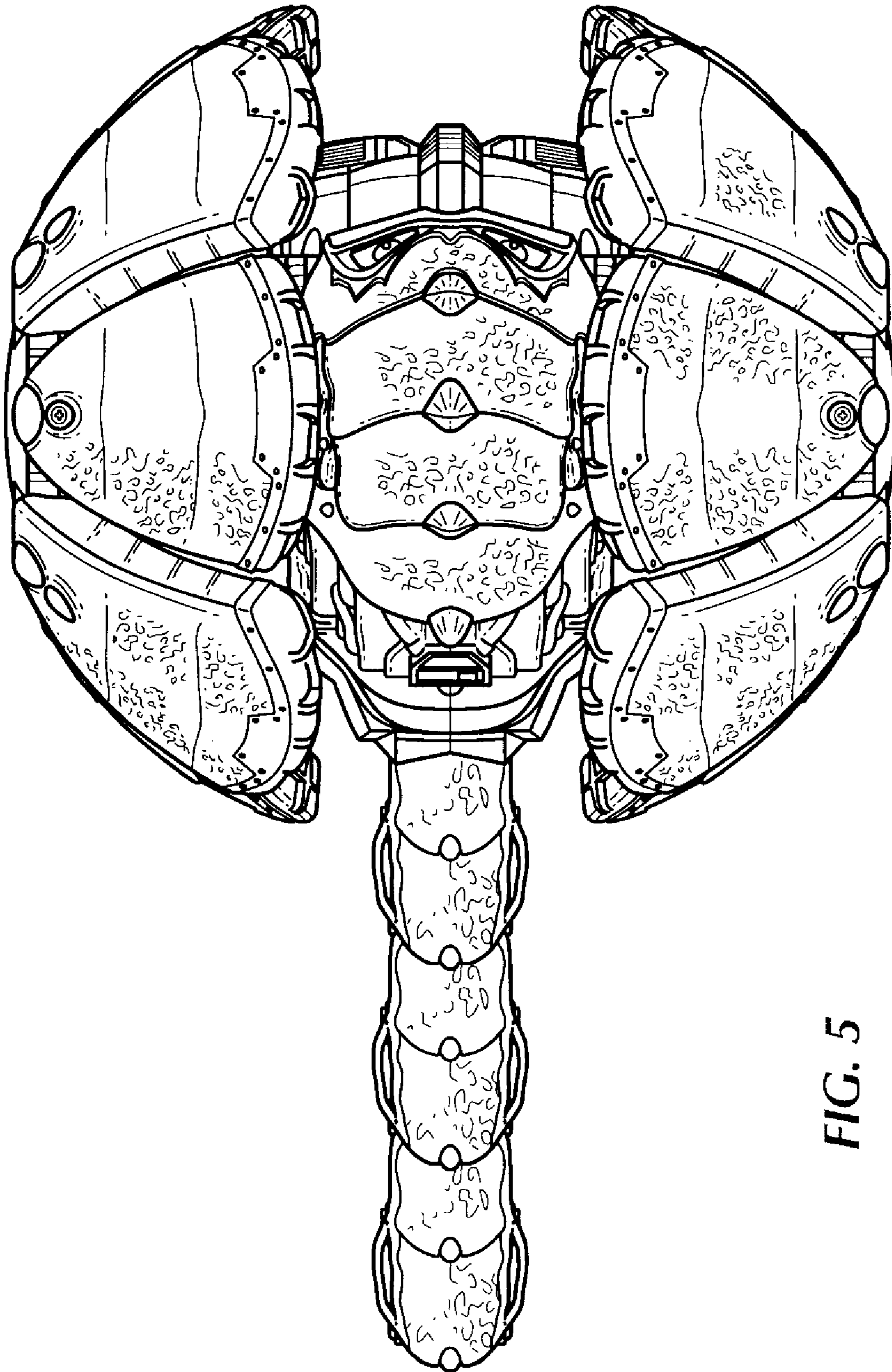

FIG. 5

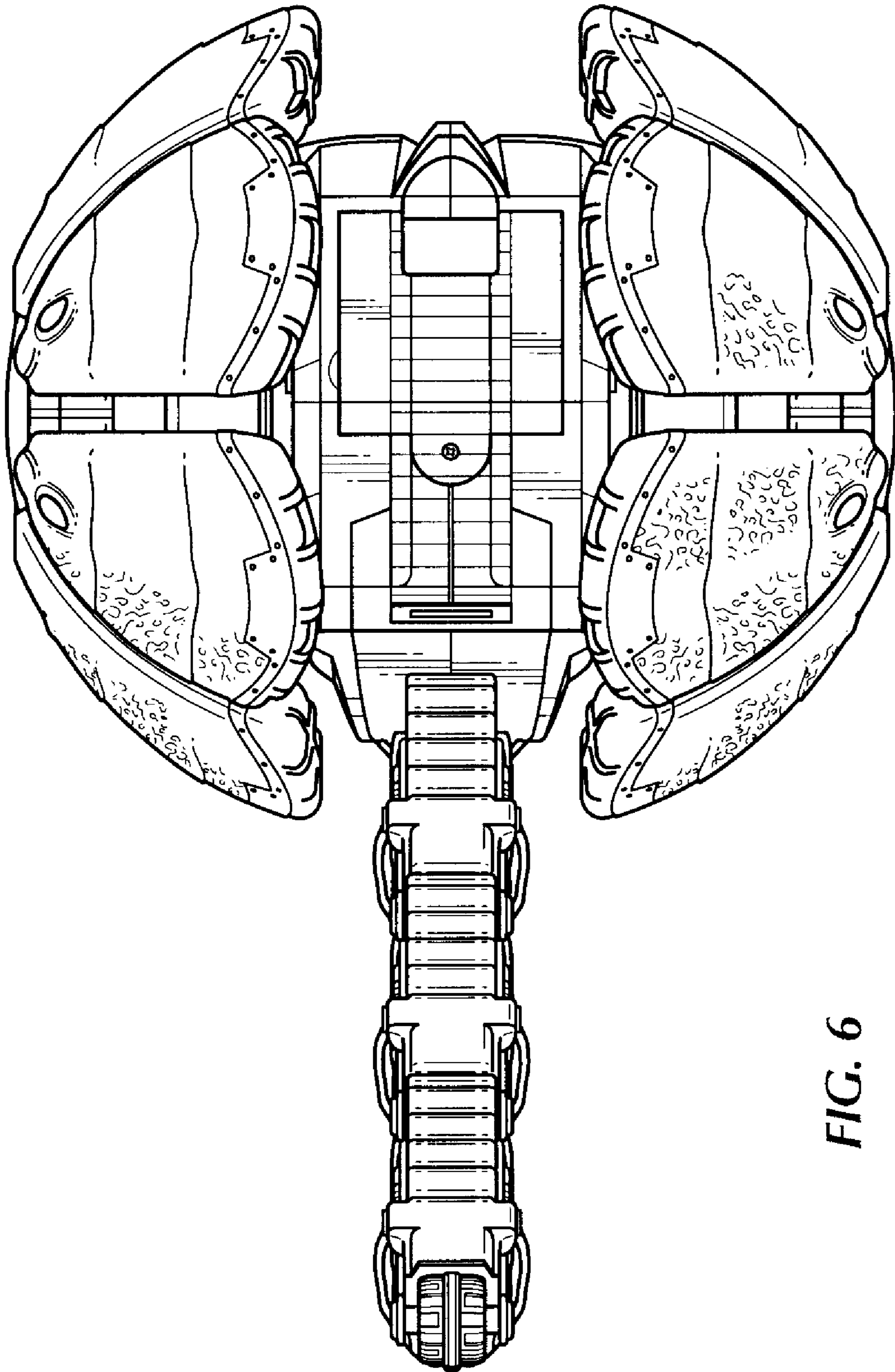

FIG. 6

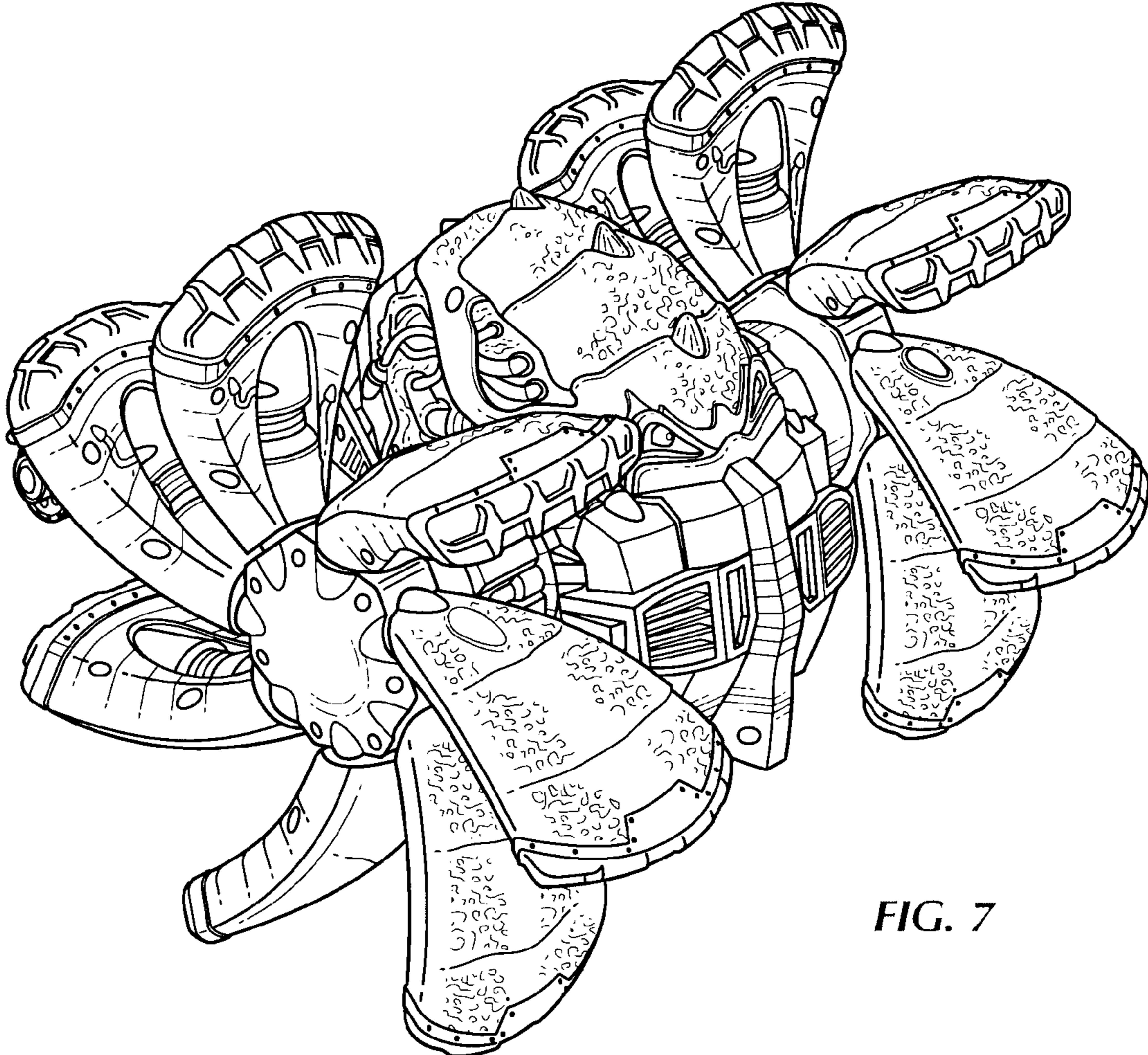

FIG. 7

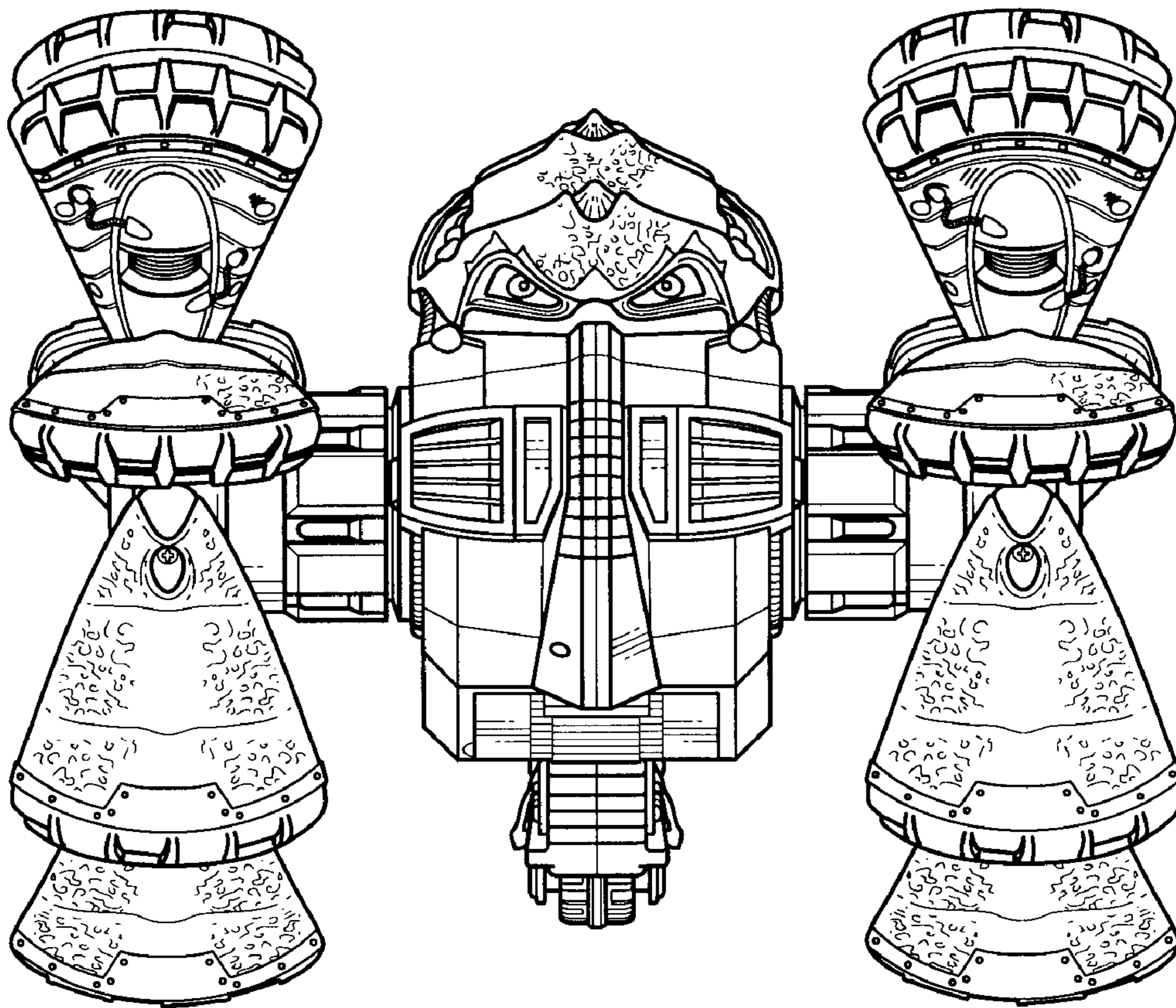

FIG. 8

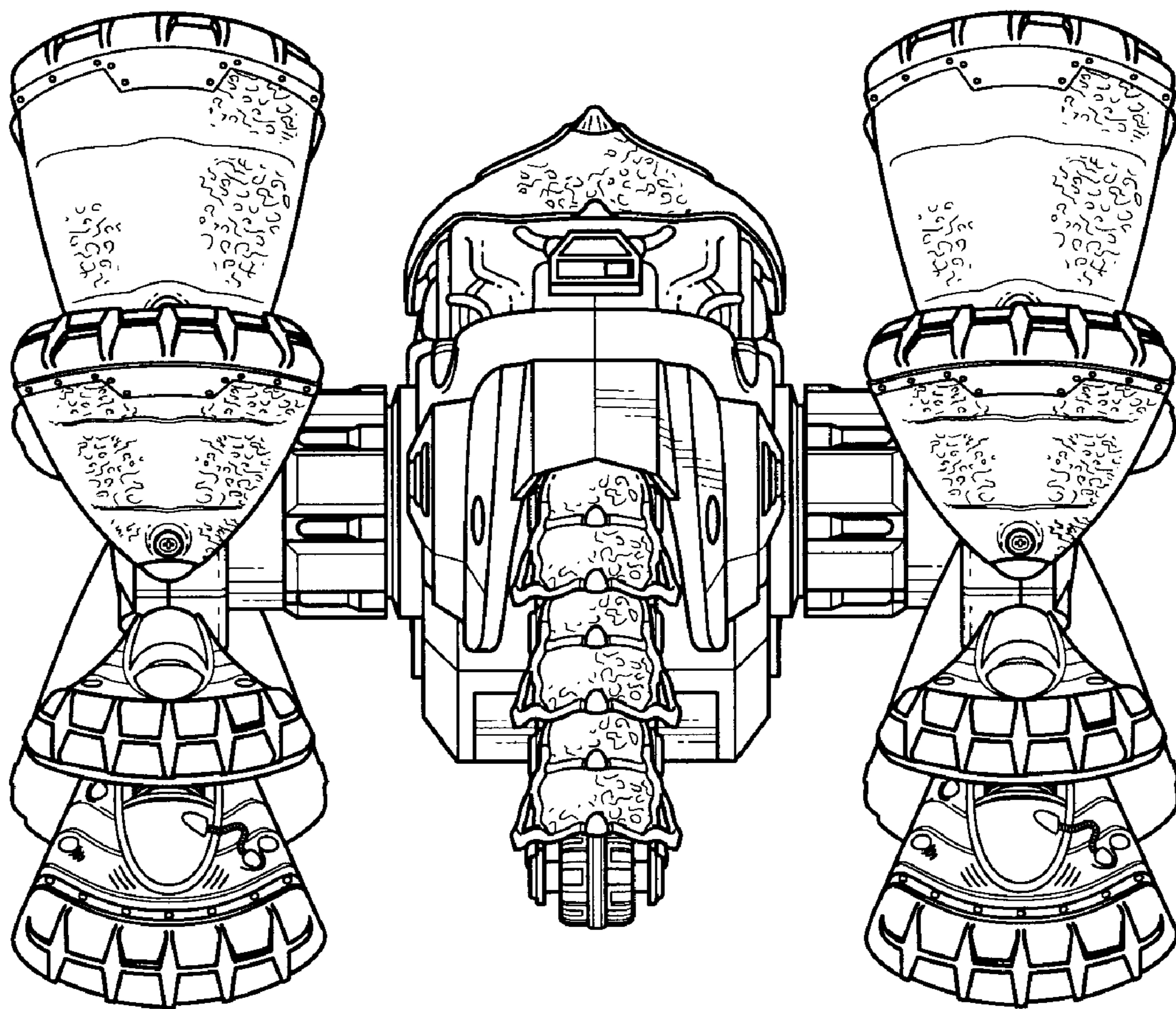

FIG. 9

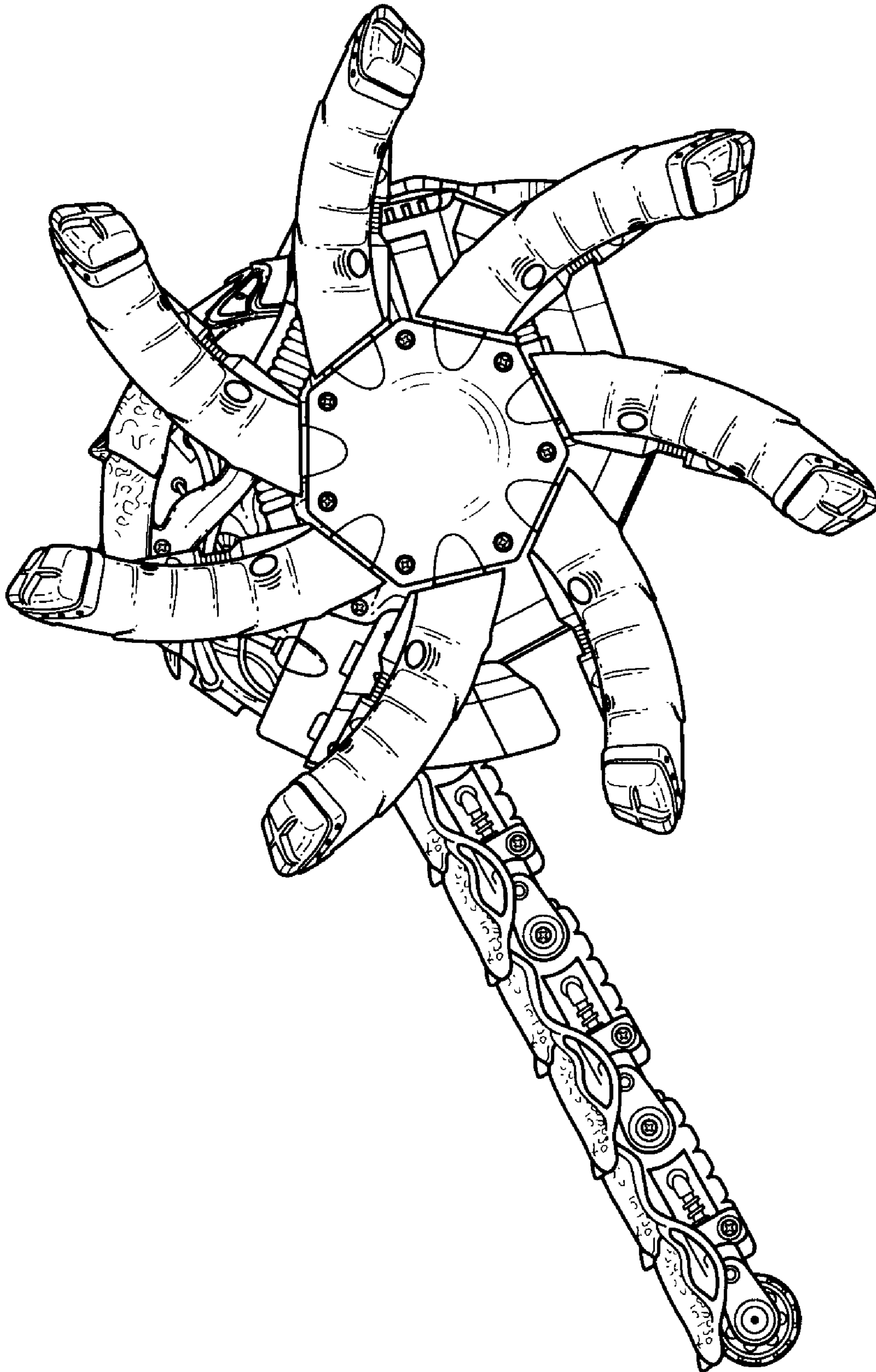

FIG. 10

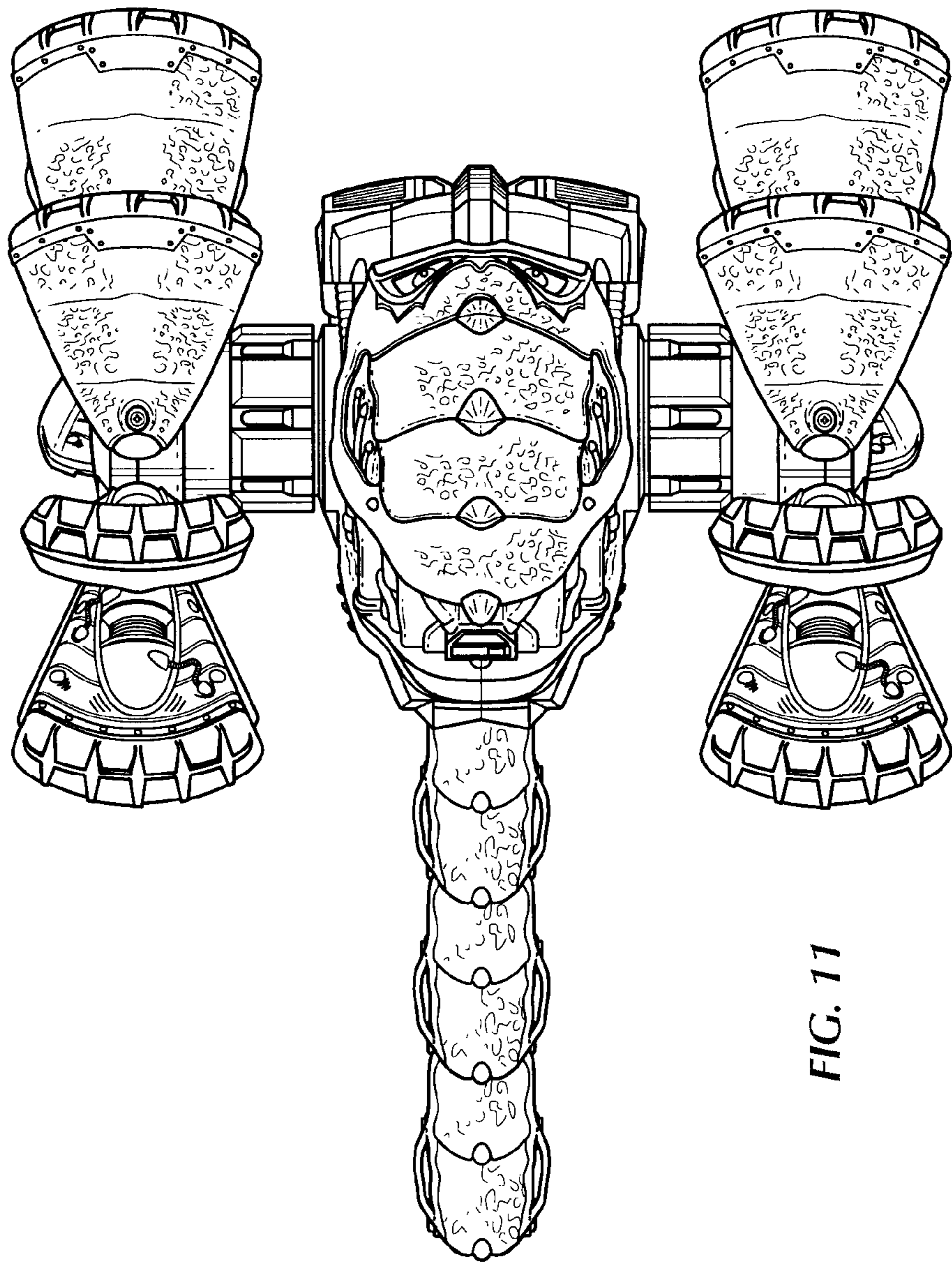

FIG. 11

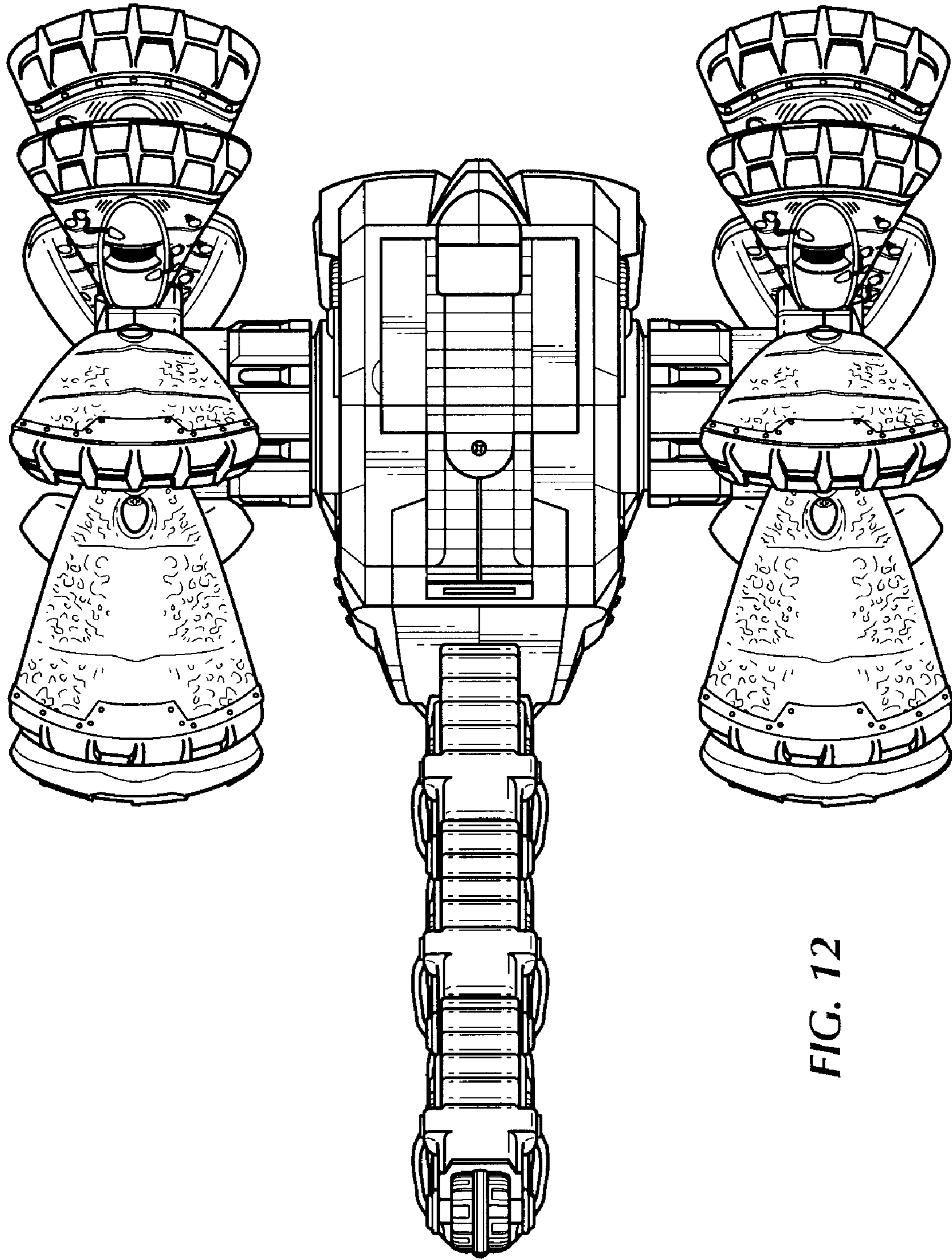

FIG. 12

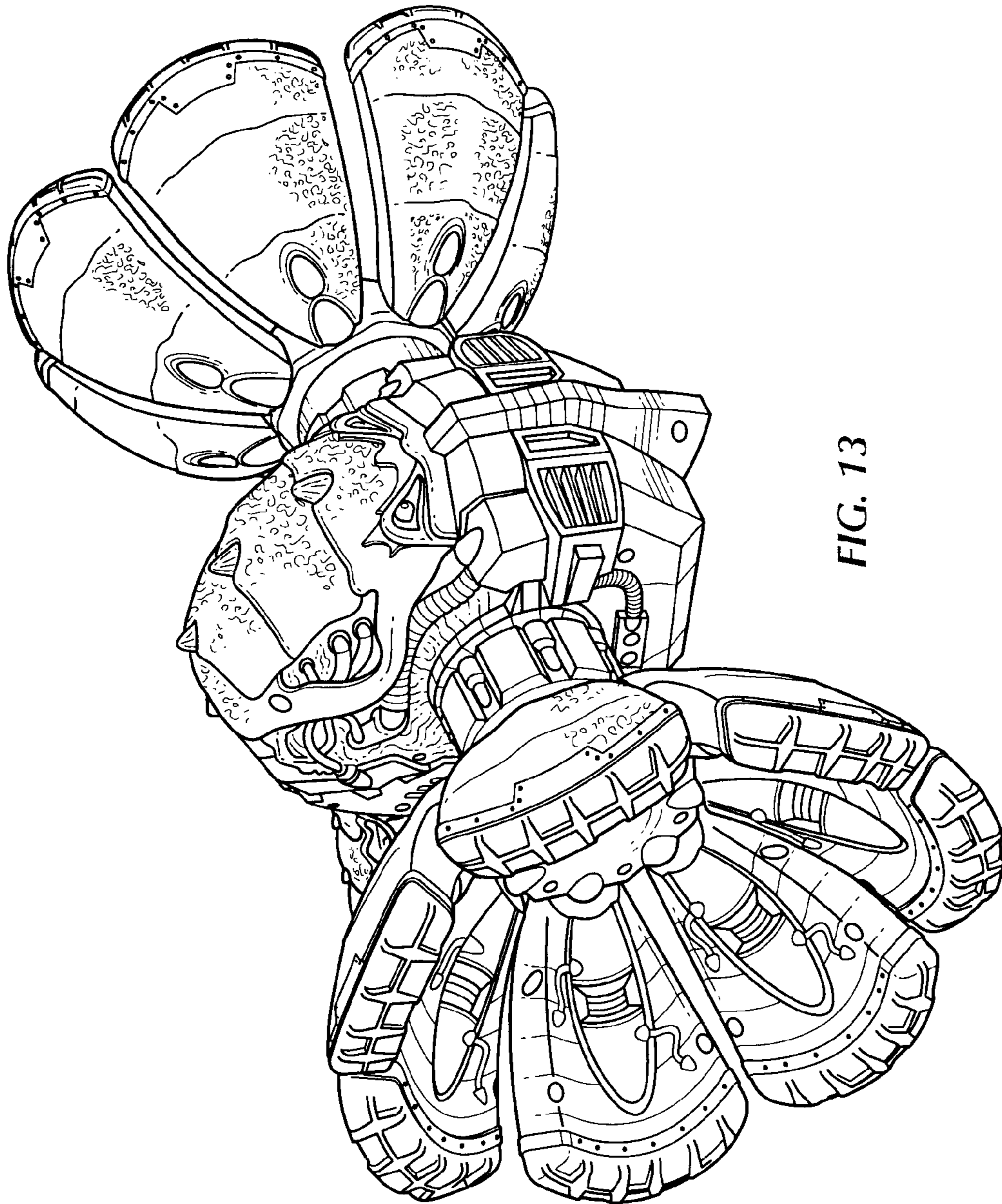

FIG. 13

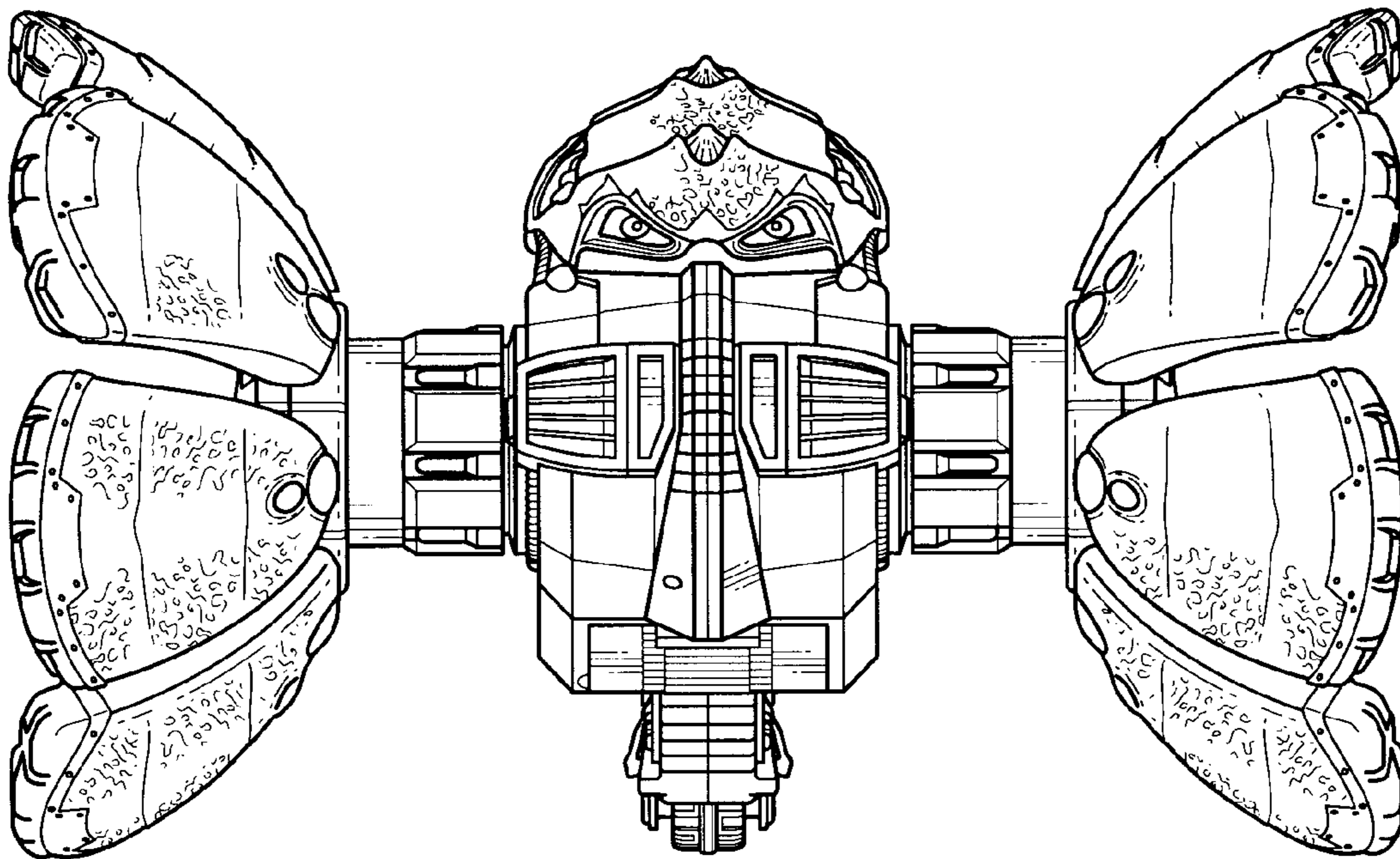

FIG. 14

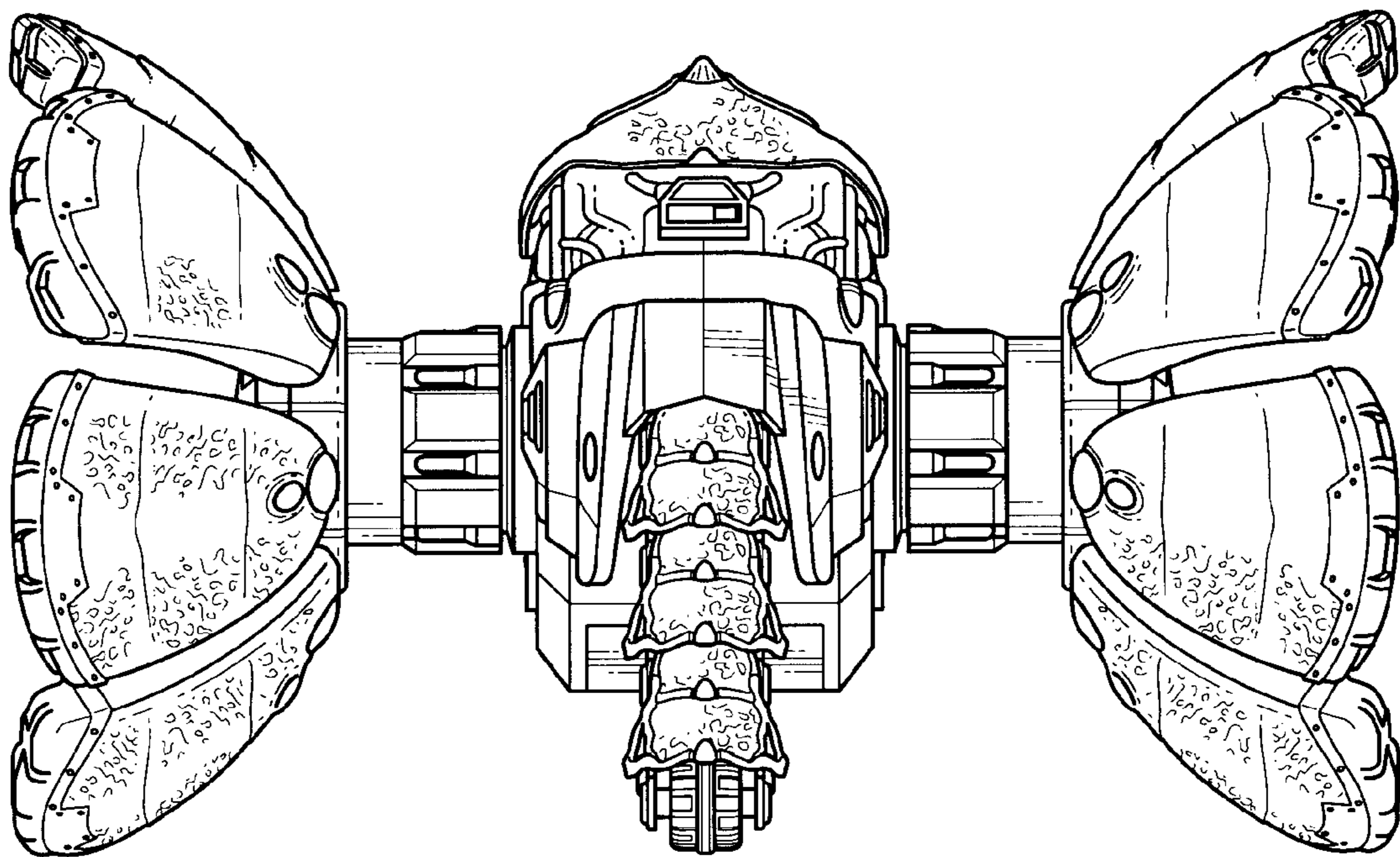

FIG. 15

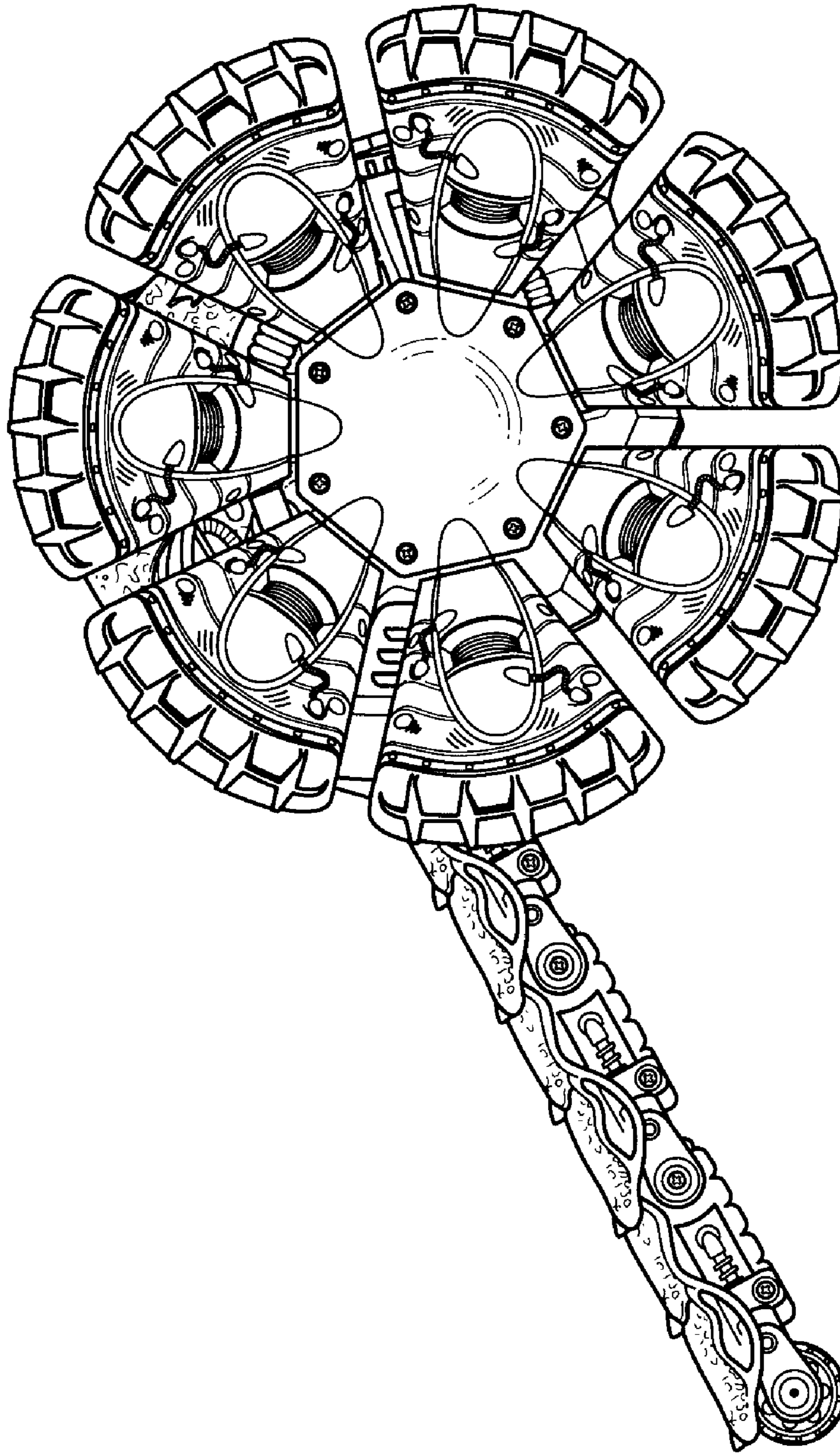

FIG. 16

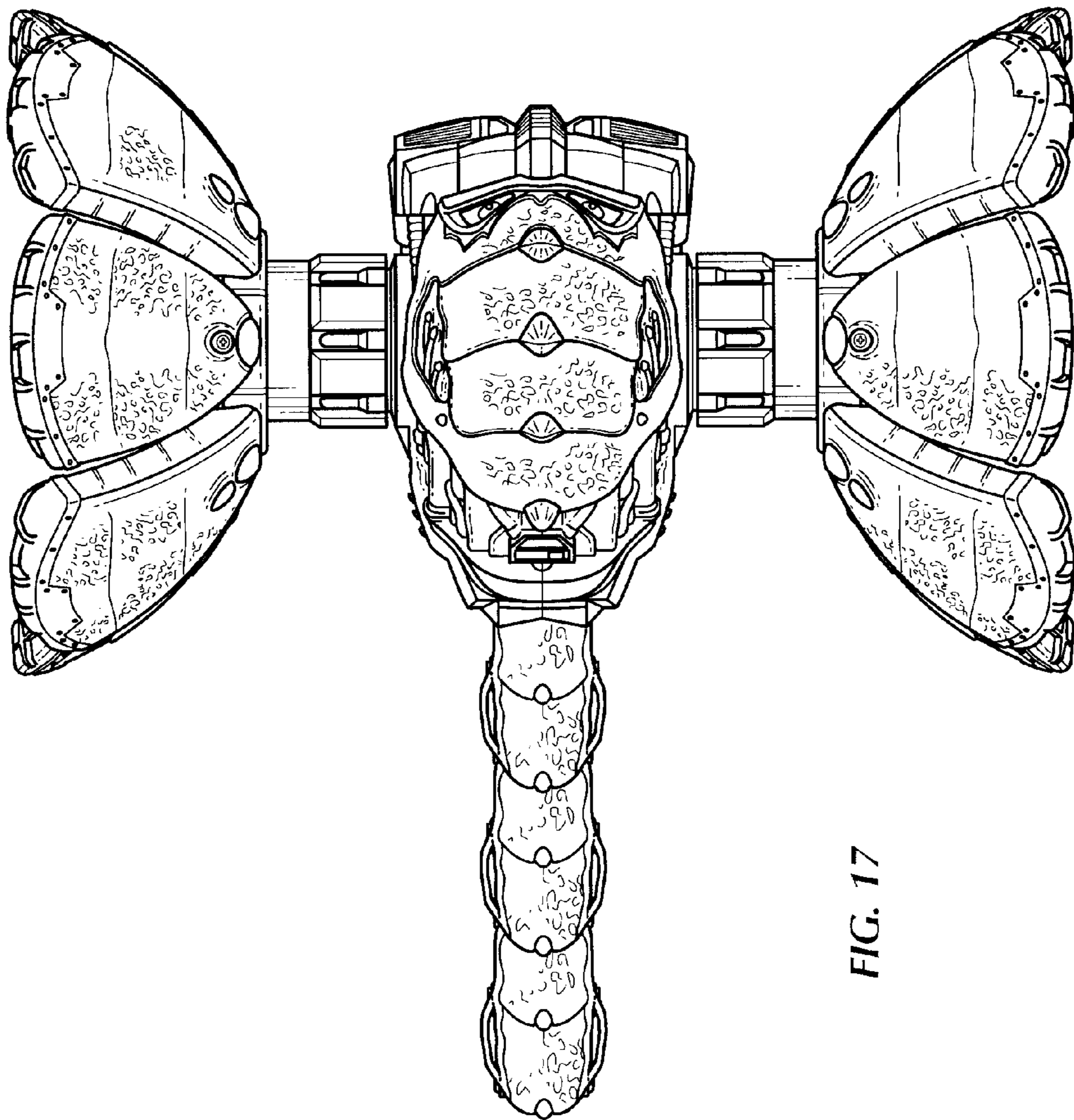

FIG. 17

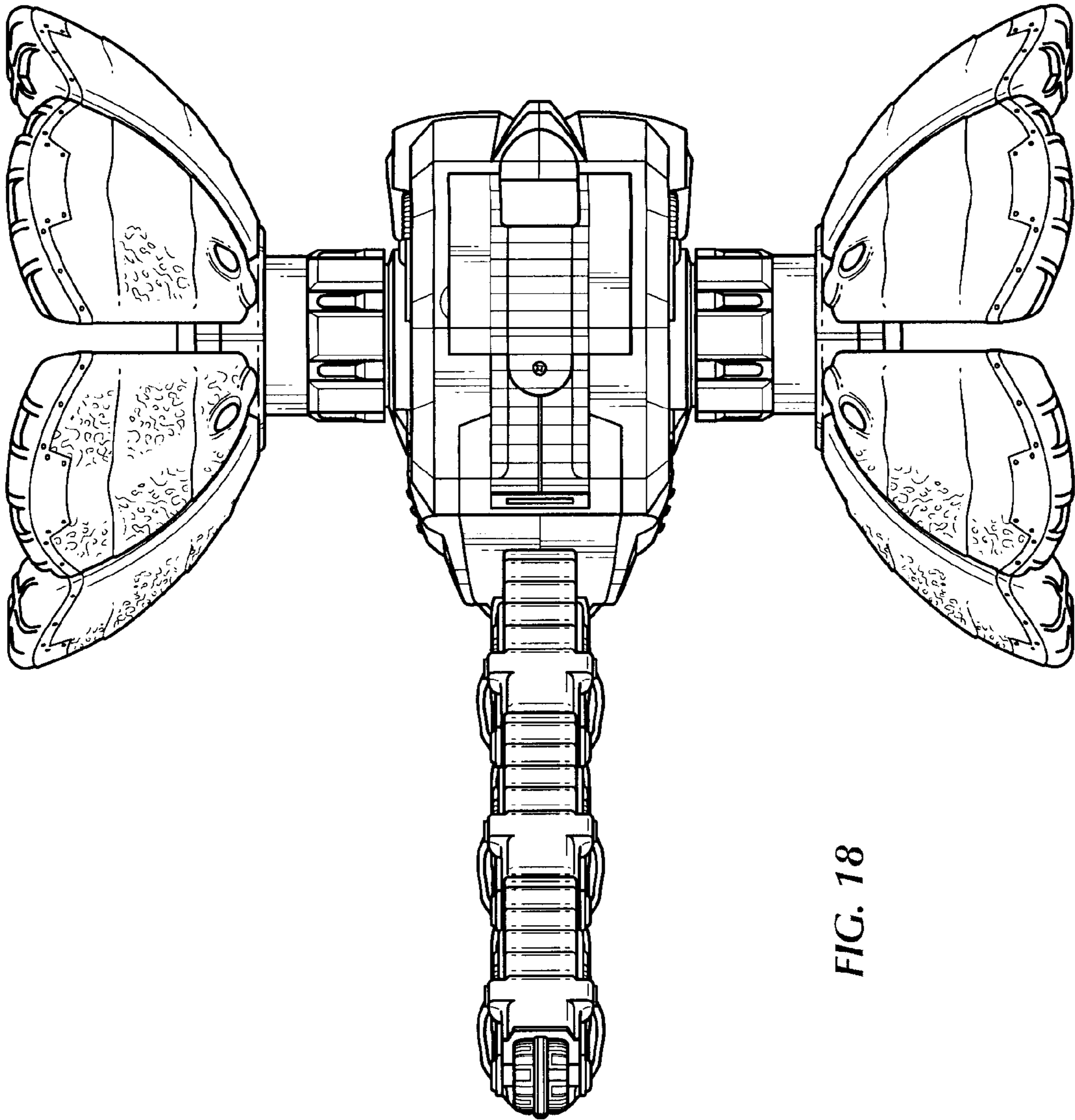

FIG. 18

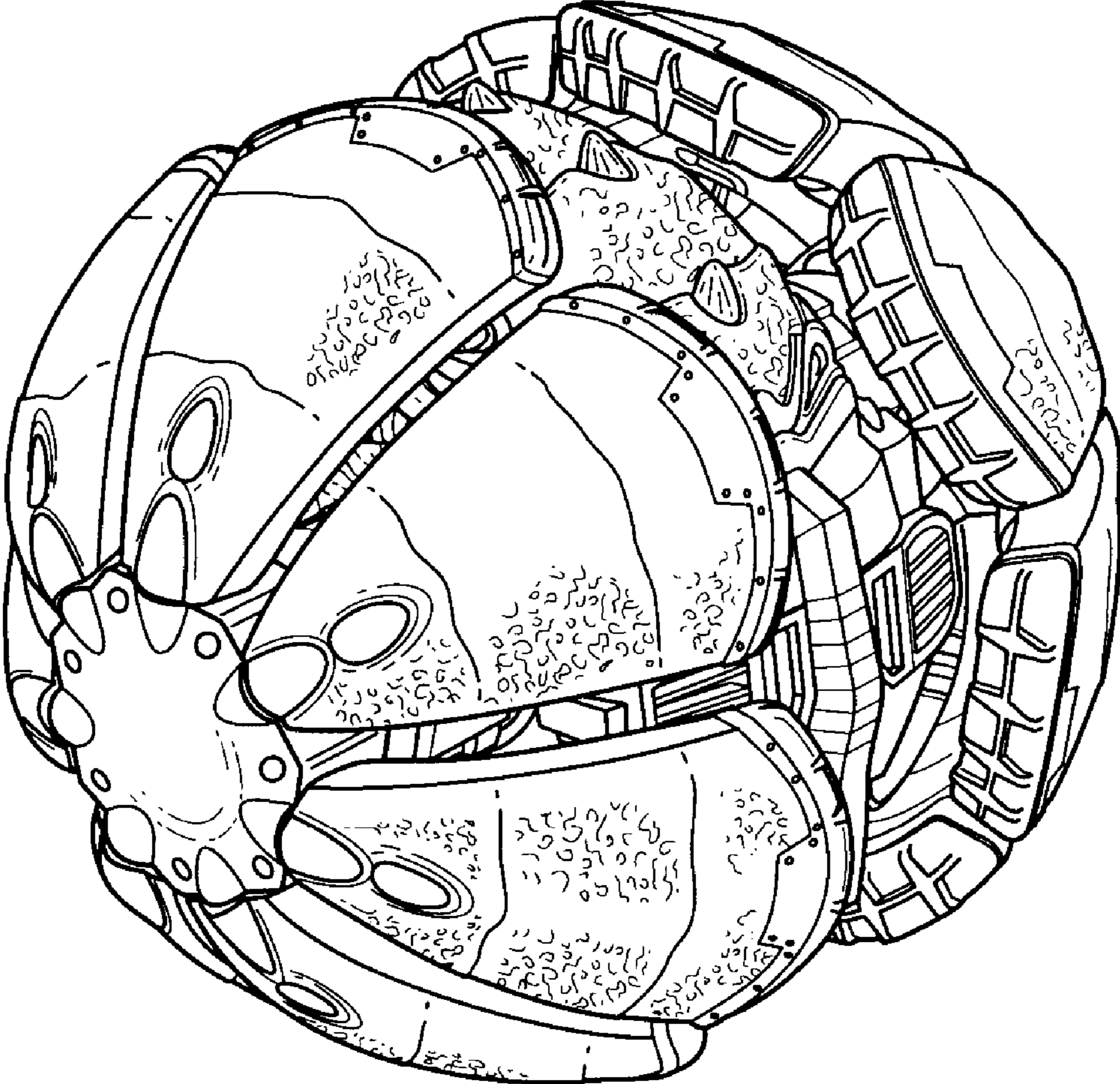

FIG. 19

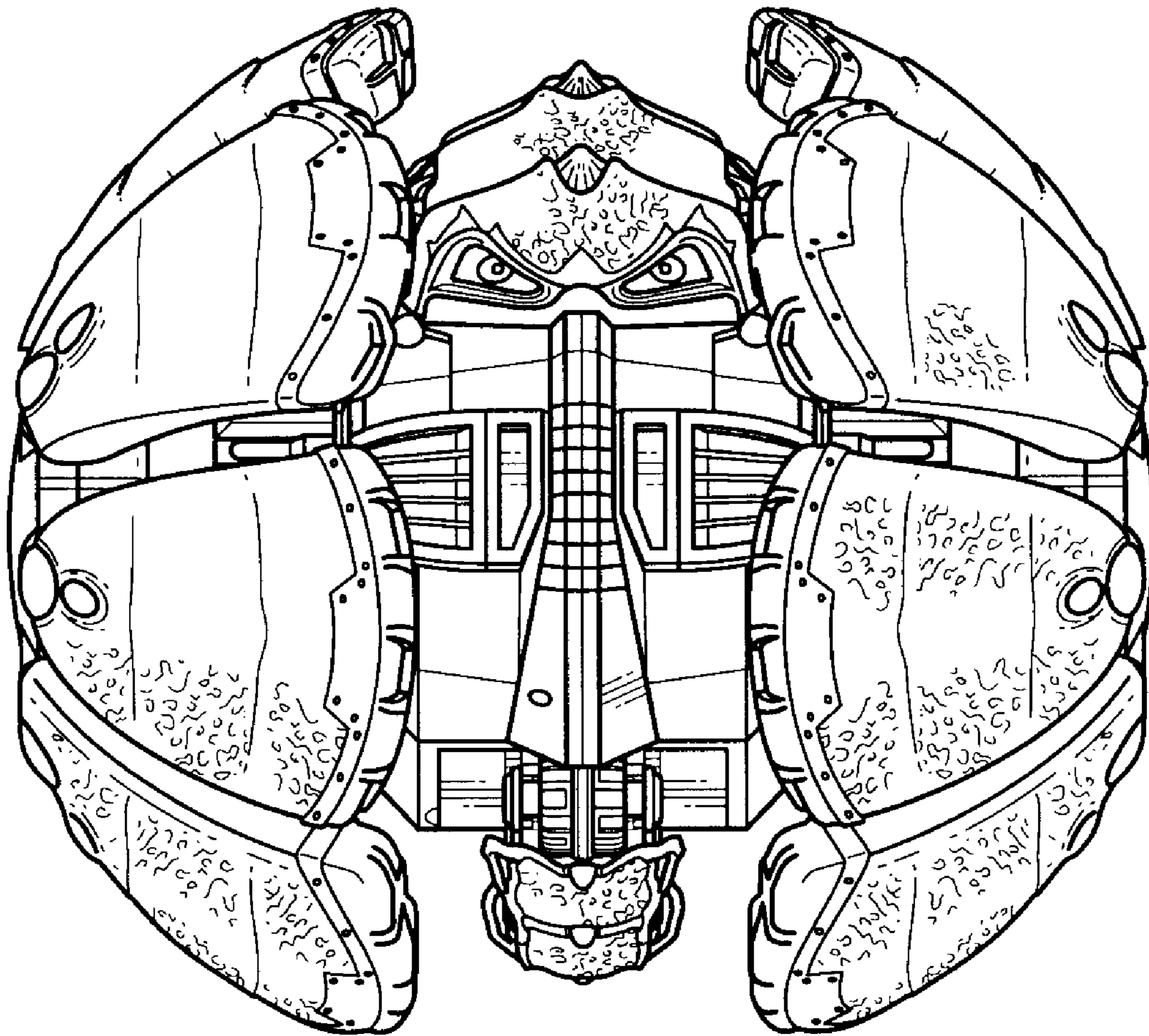

FIG. 20

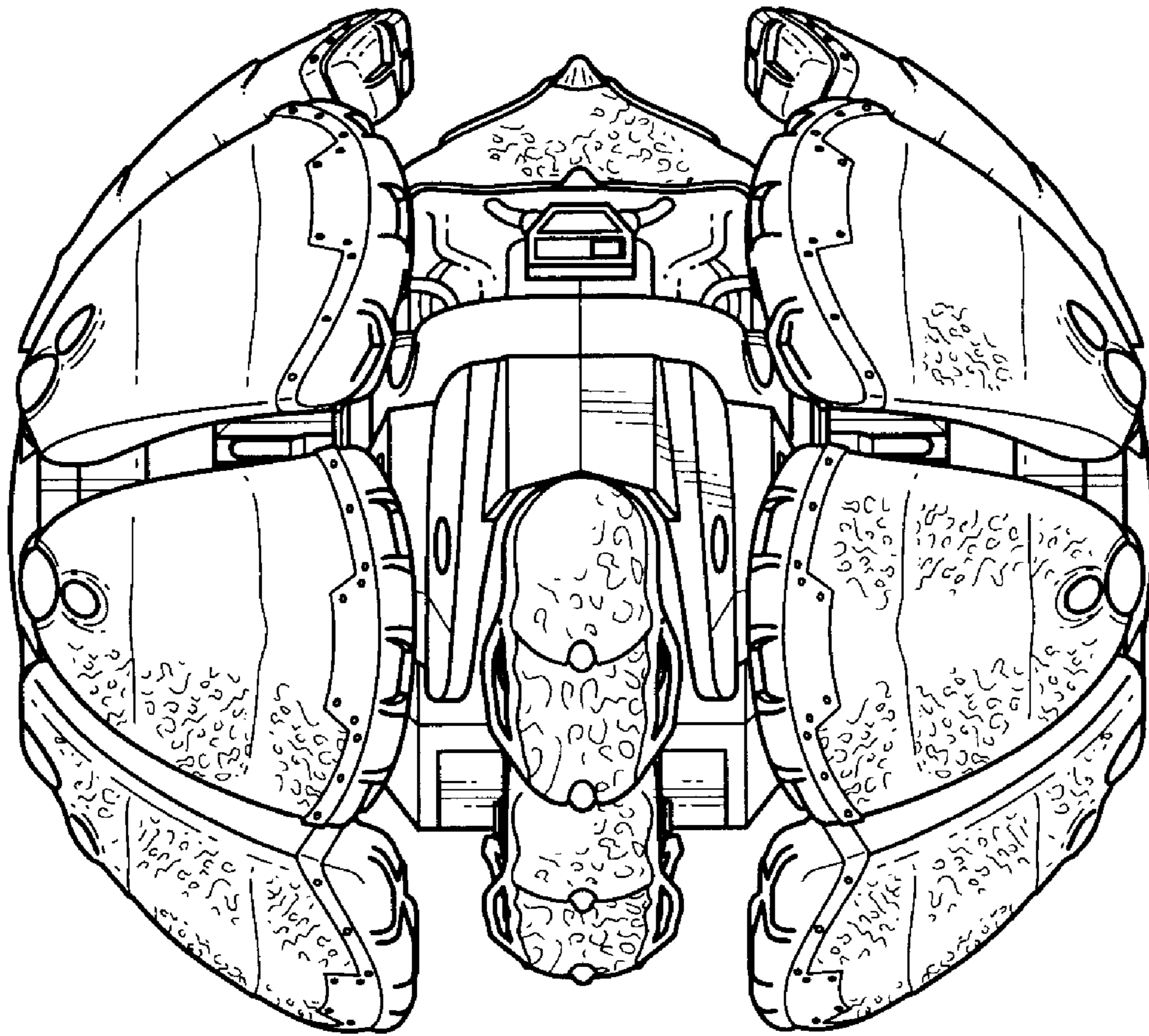

FIG. 21

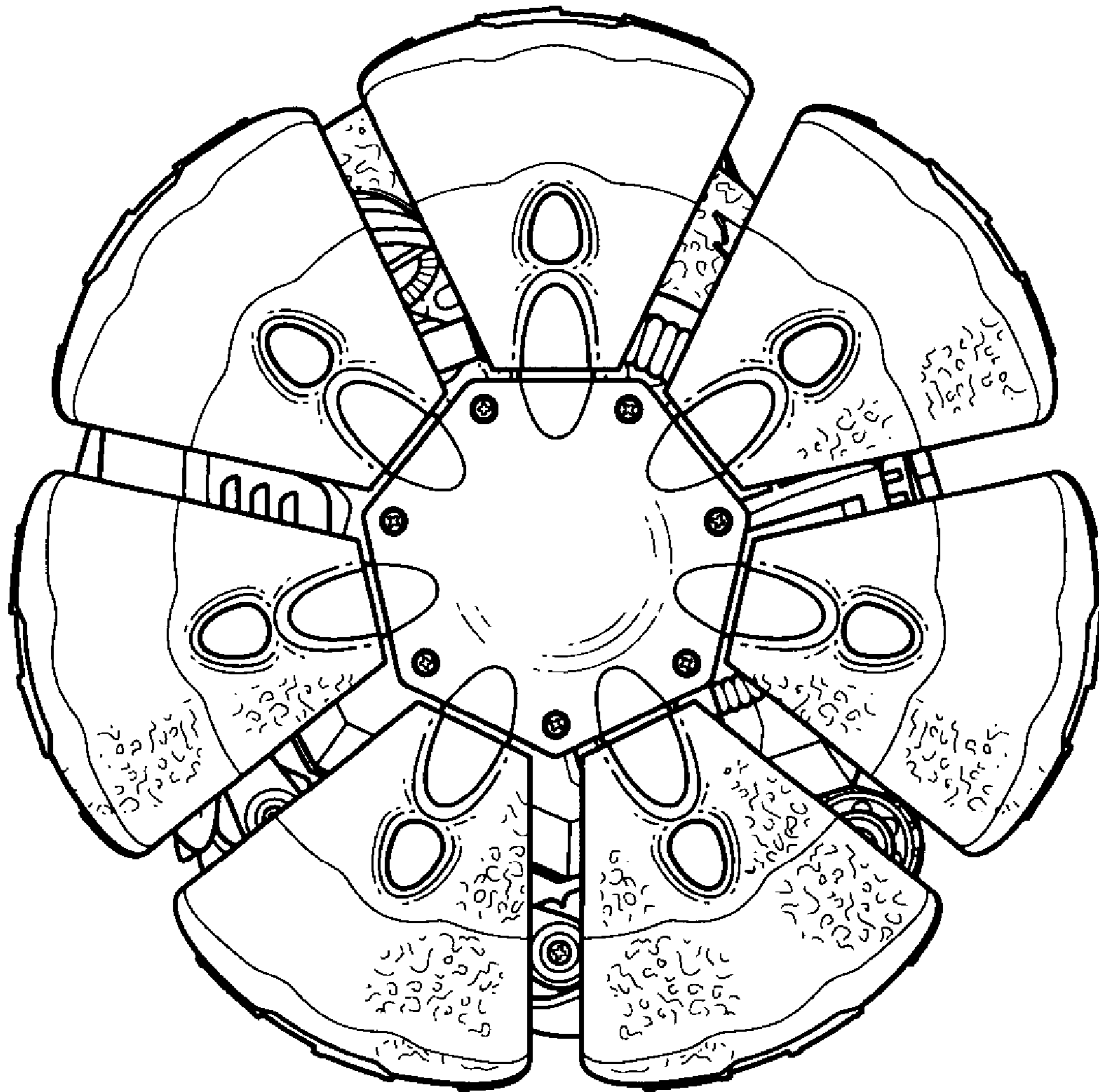

FIG. 22

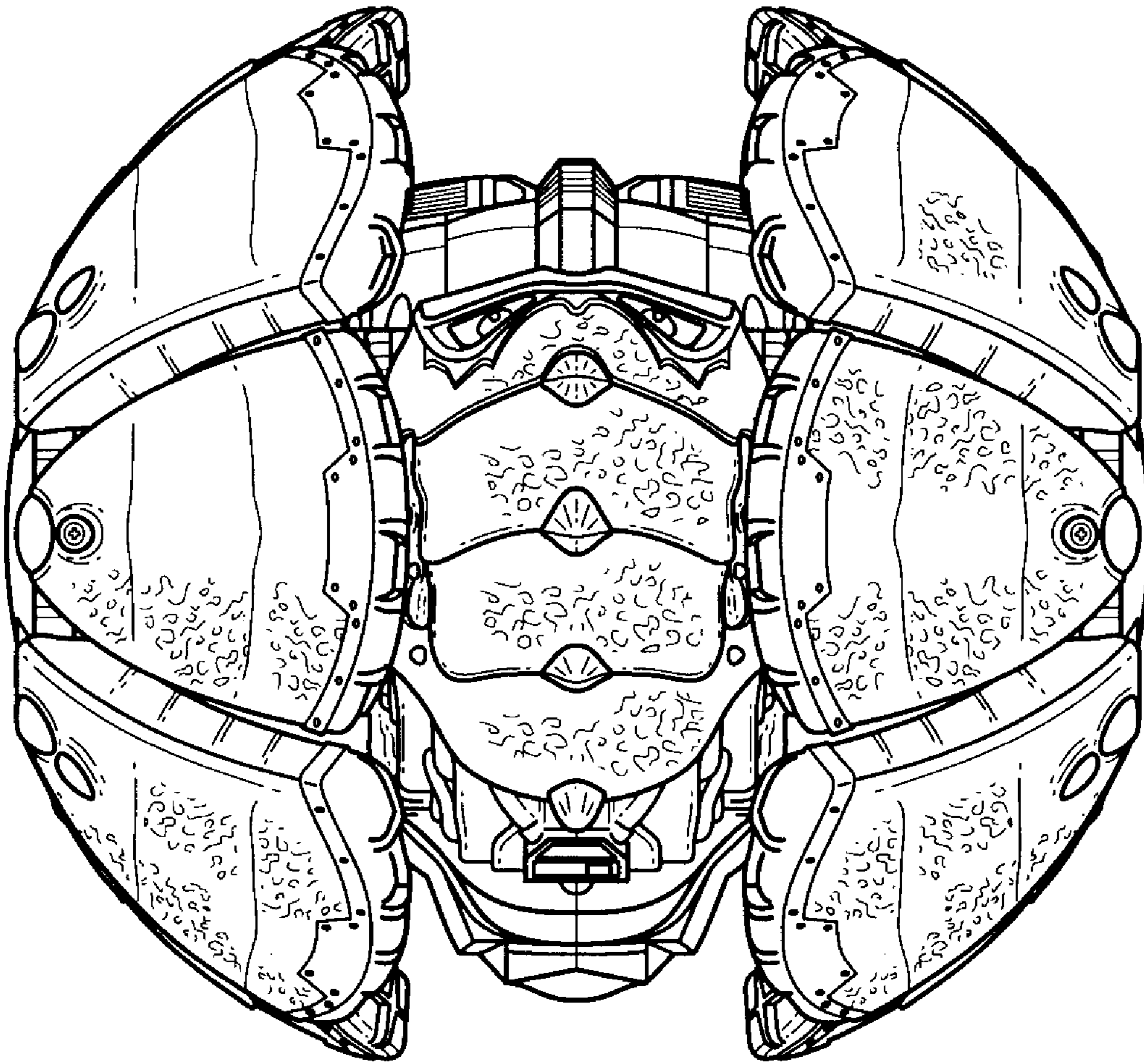

FIG. 23

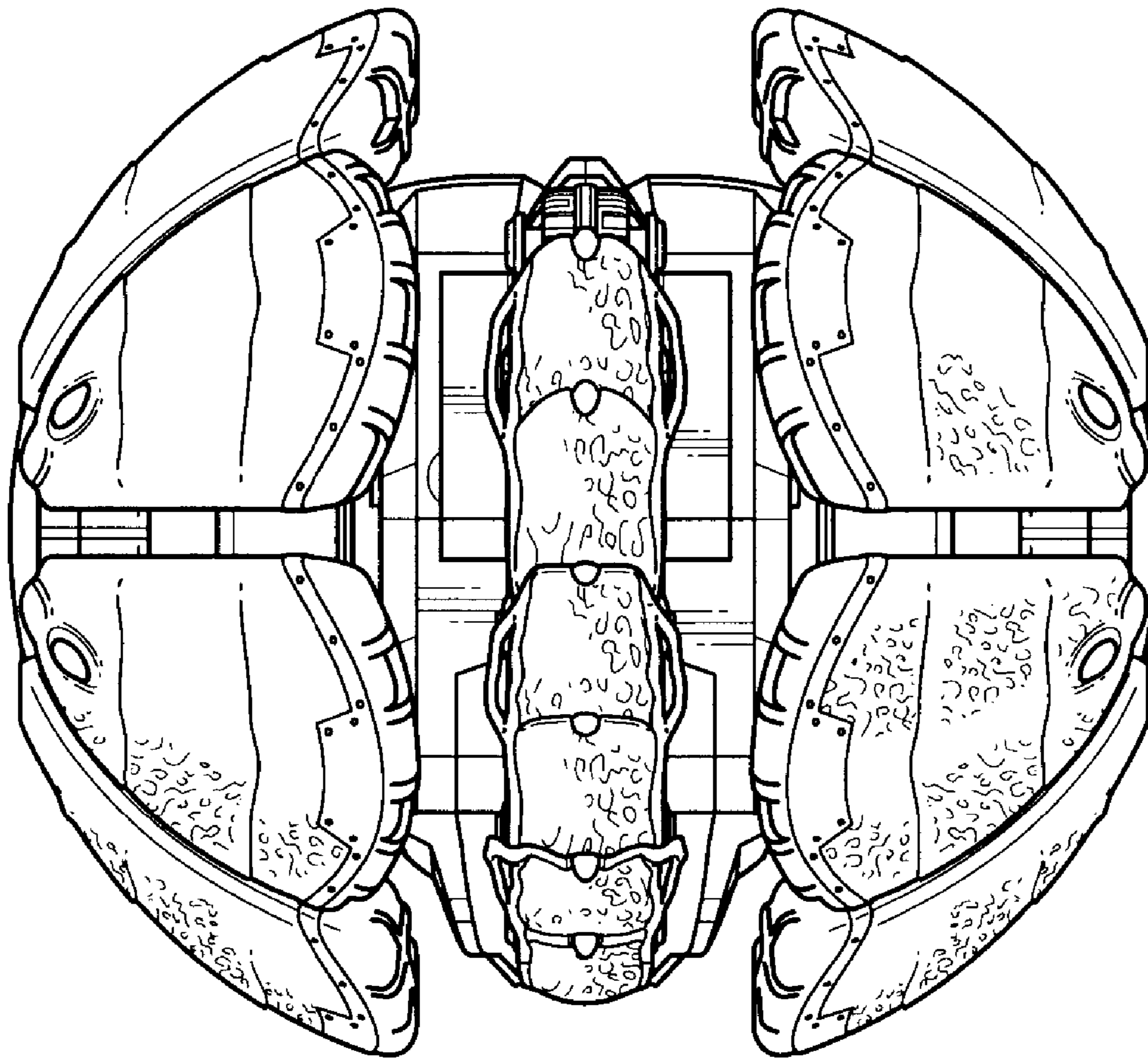

FIG. 24

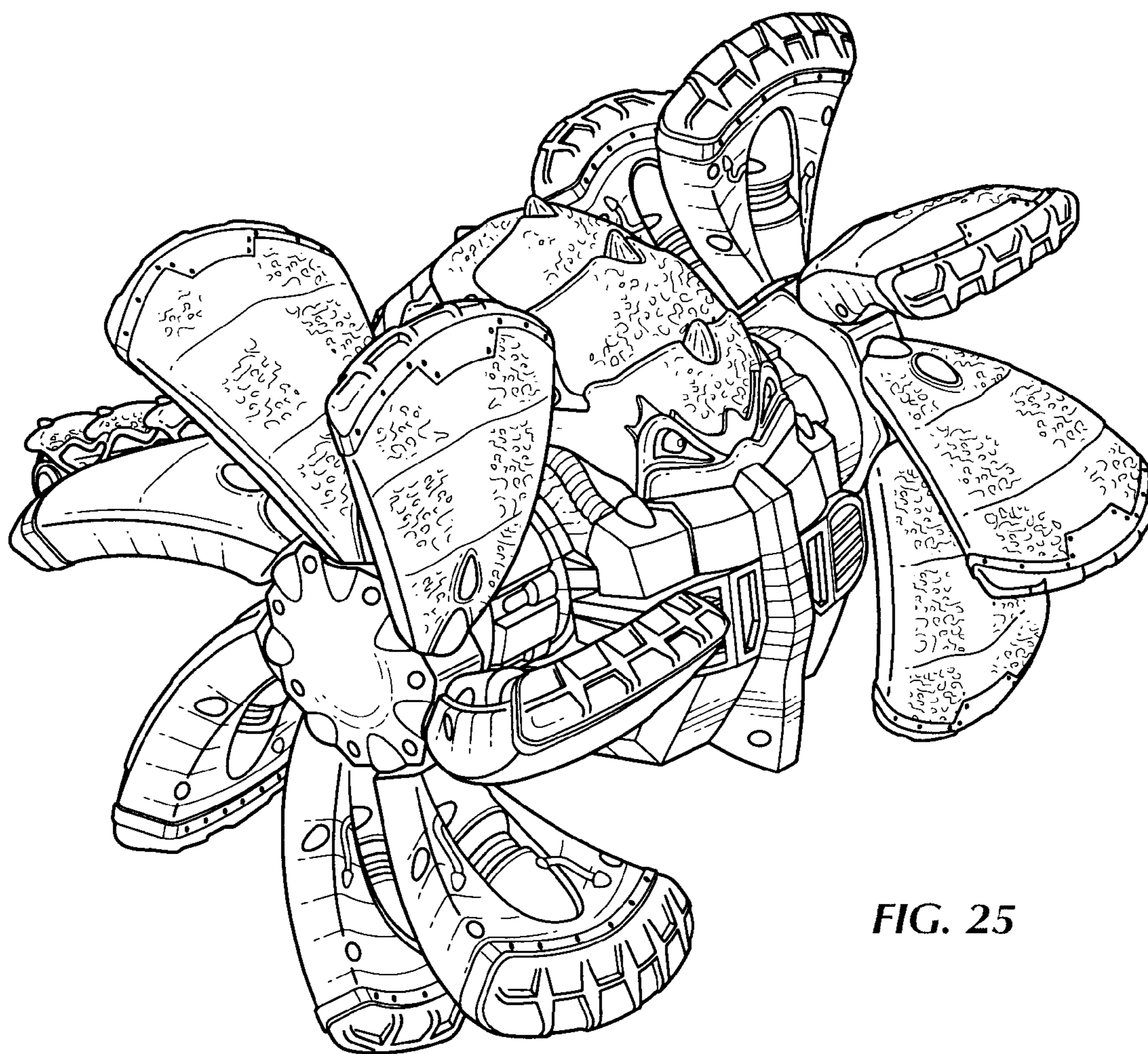

FIG. 25

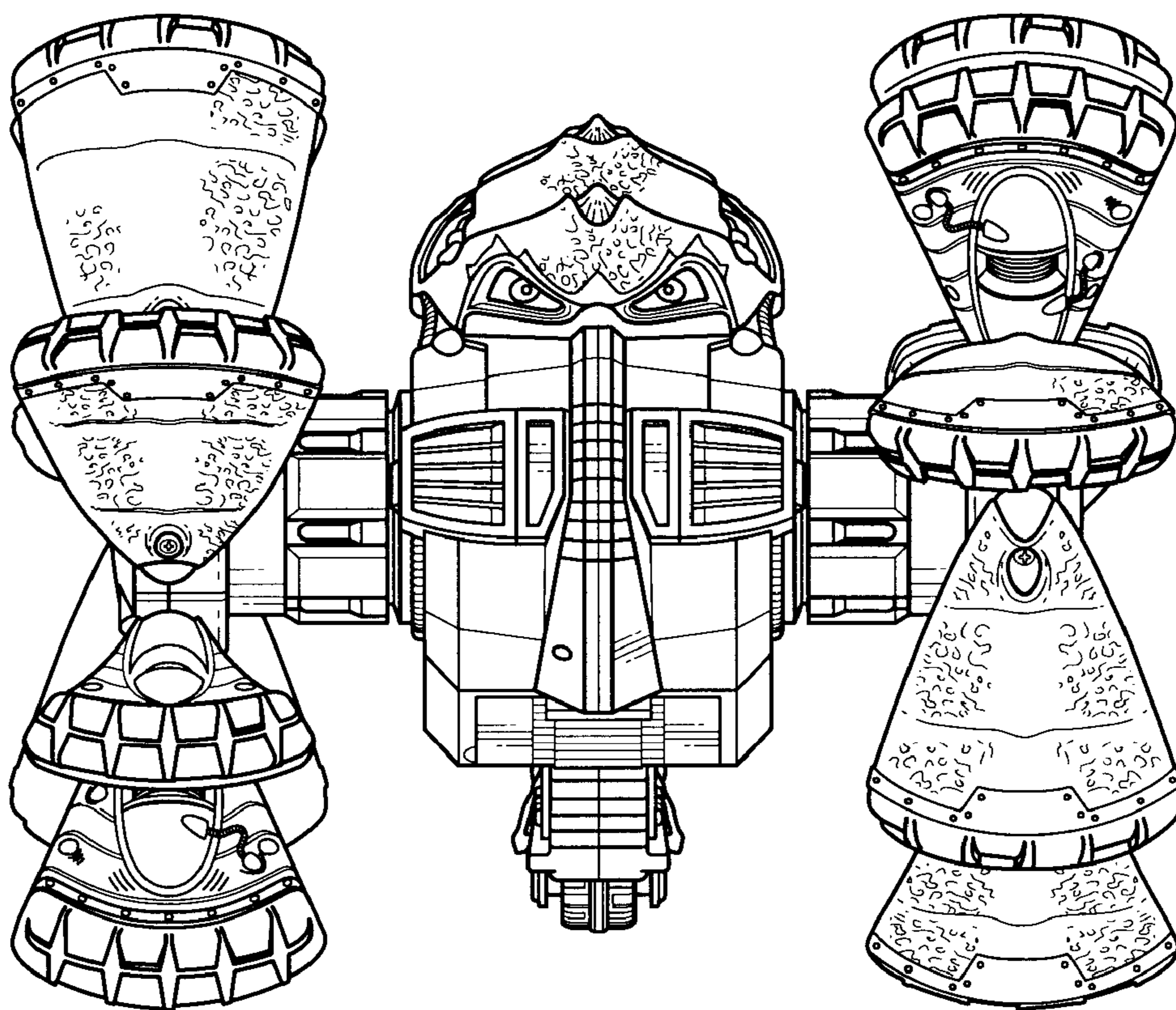

FIG. 26

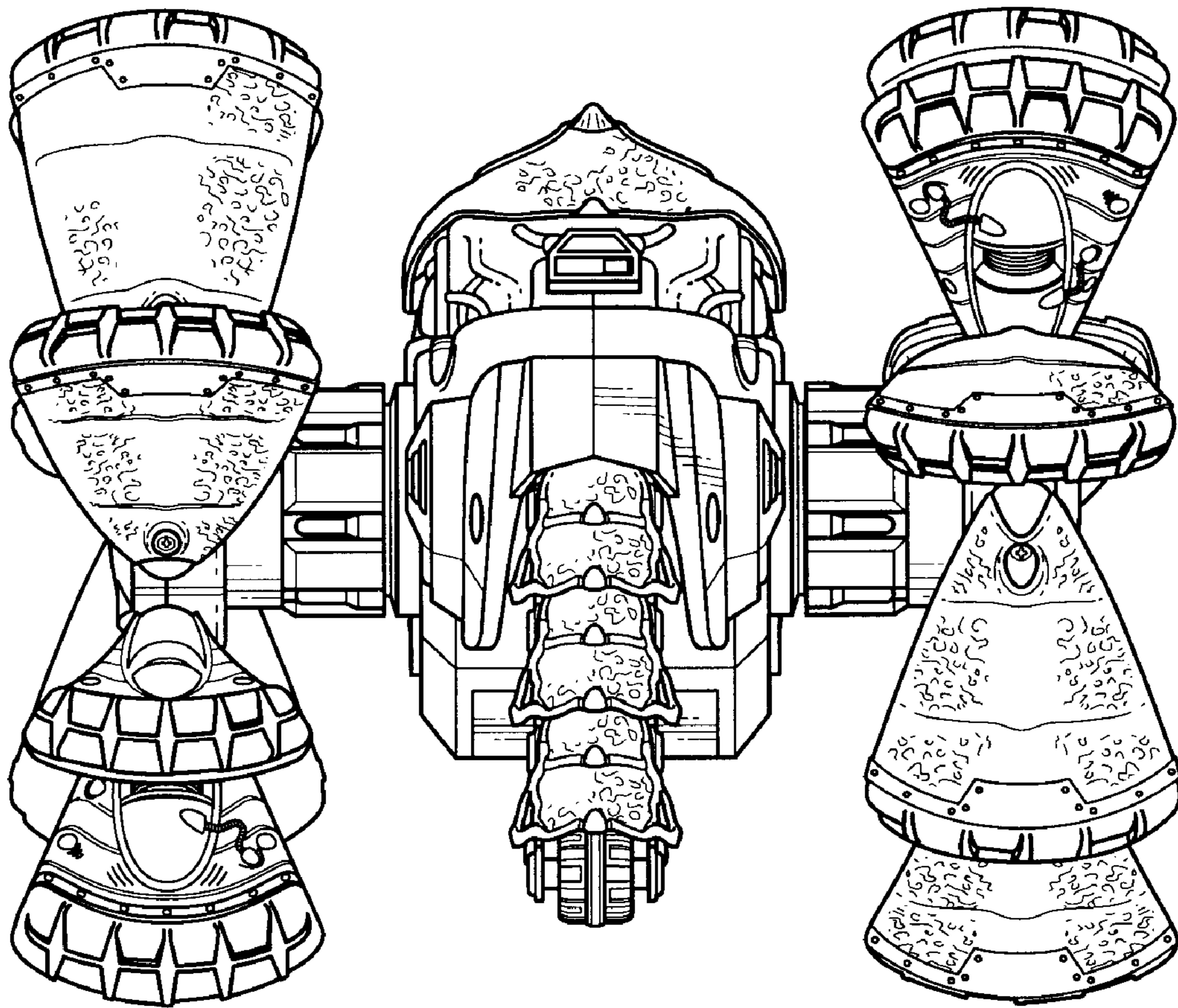

FIG. 27

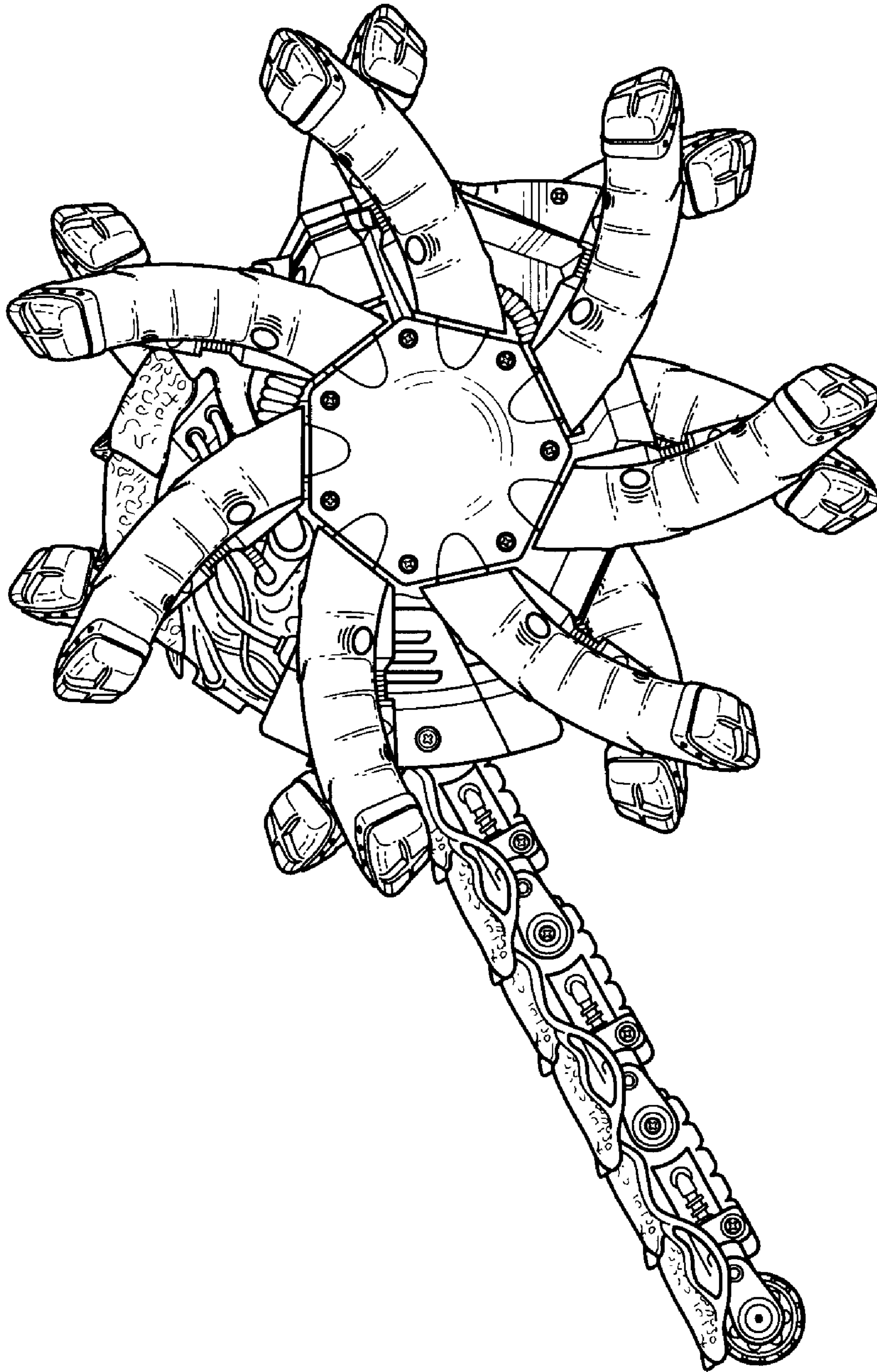

FIG. 28

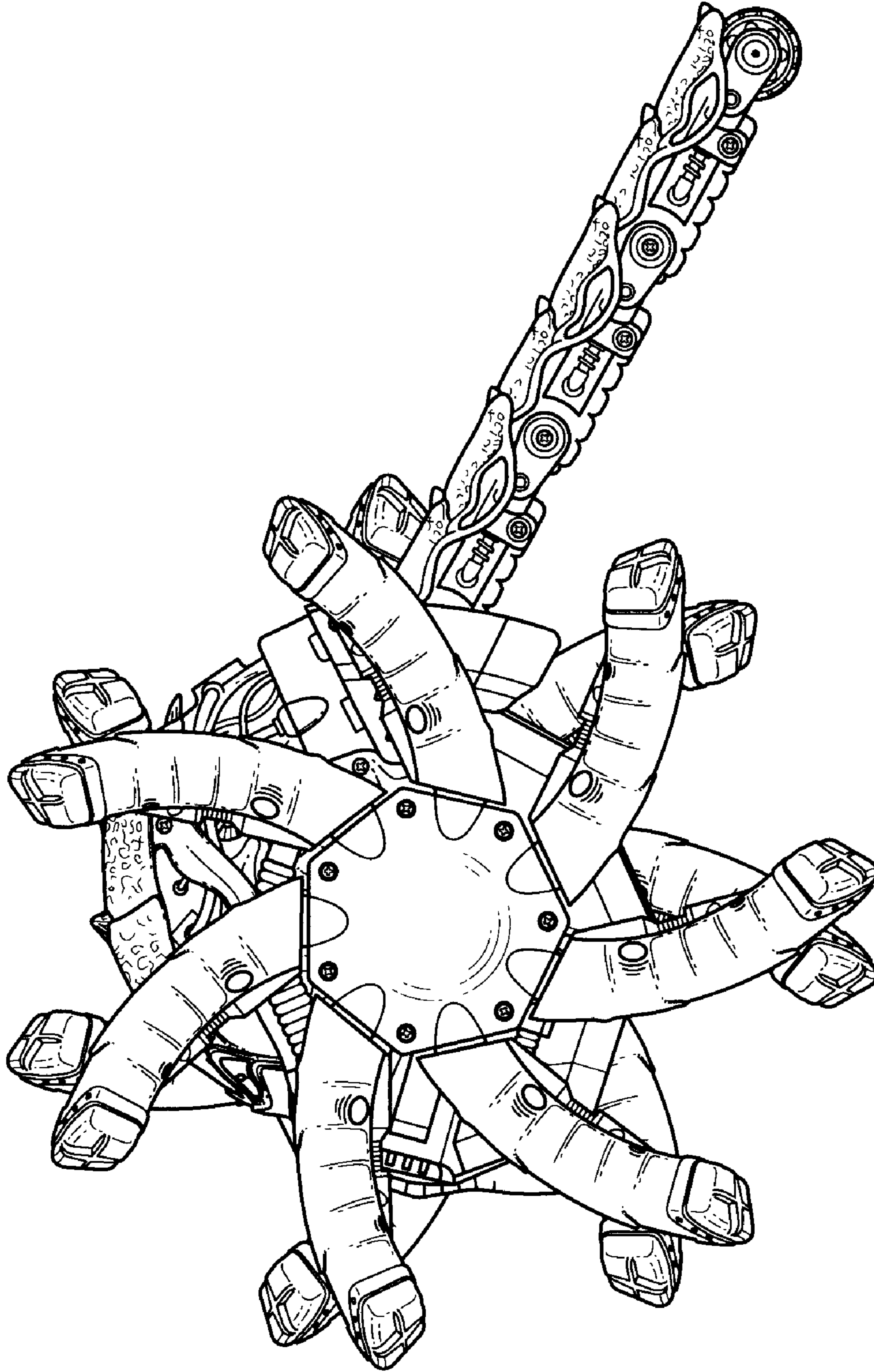

FIG. 29

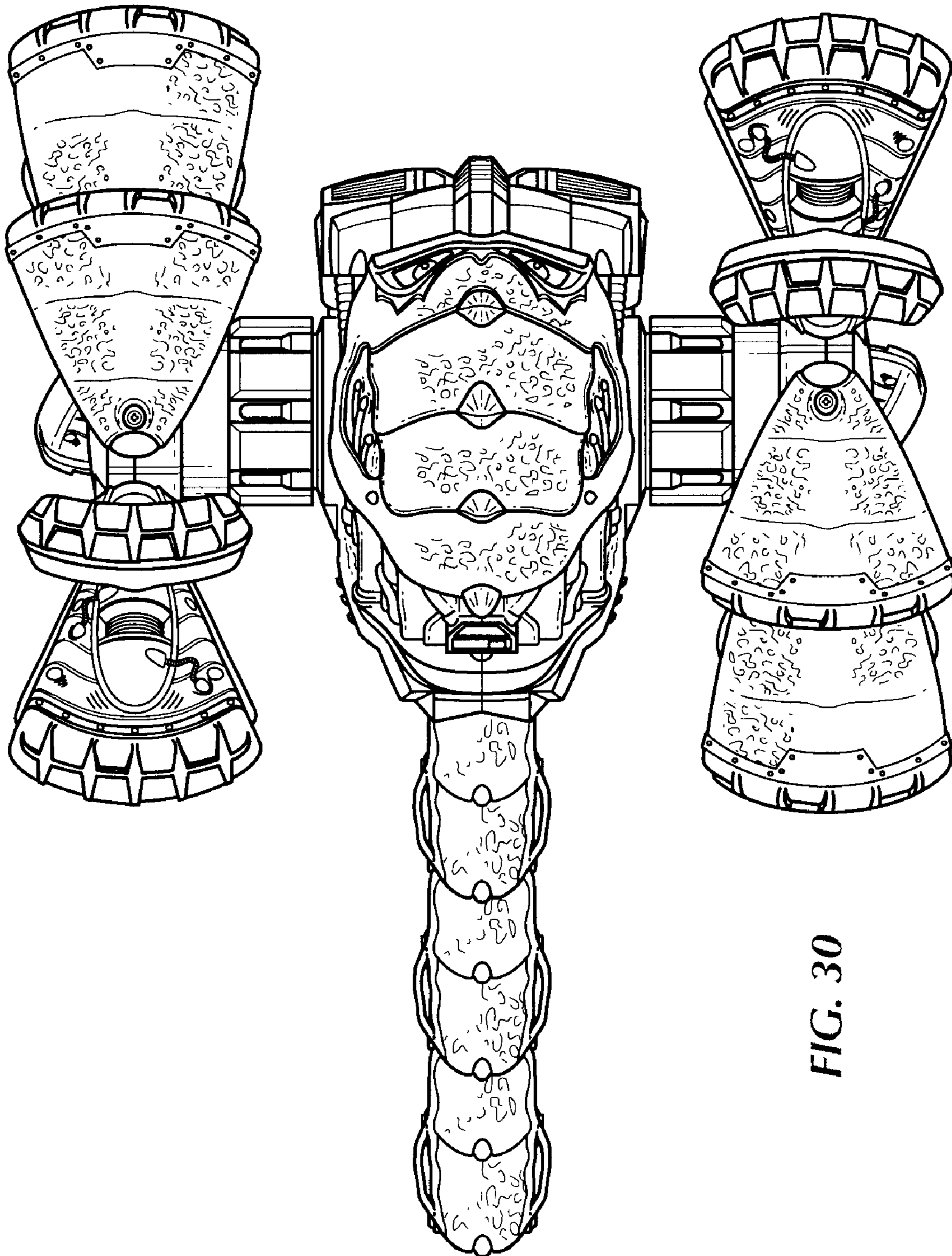

FIG. 30

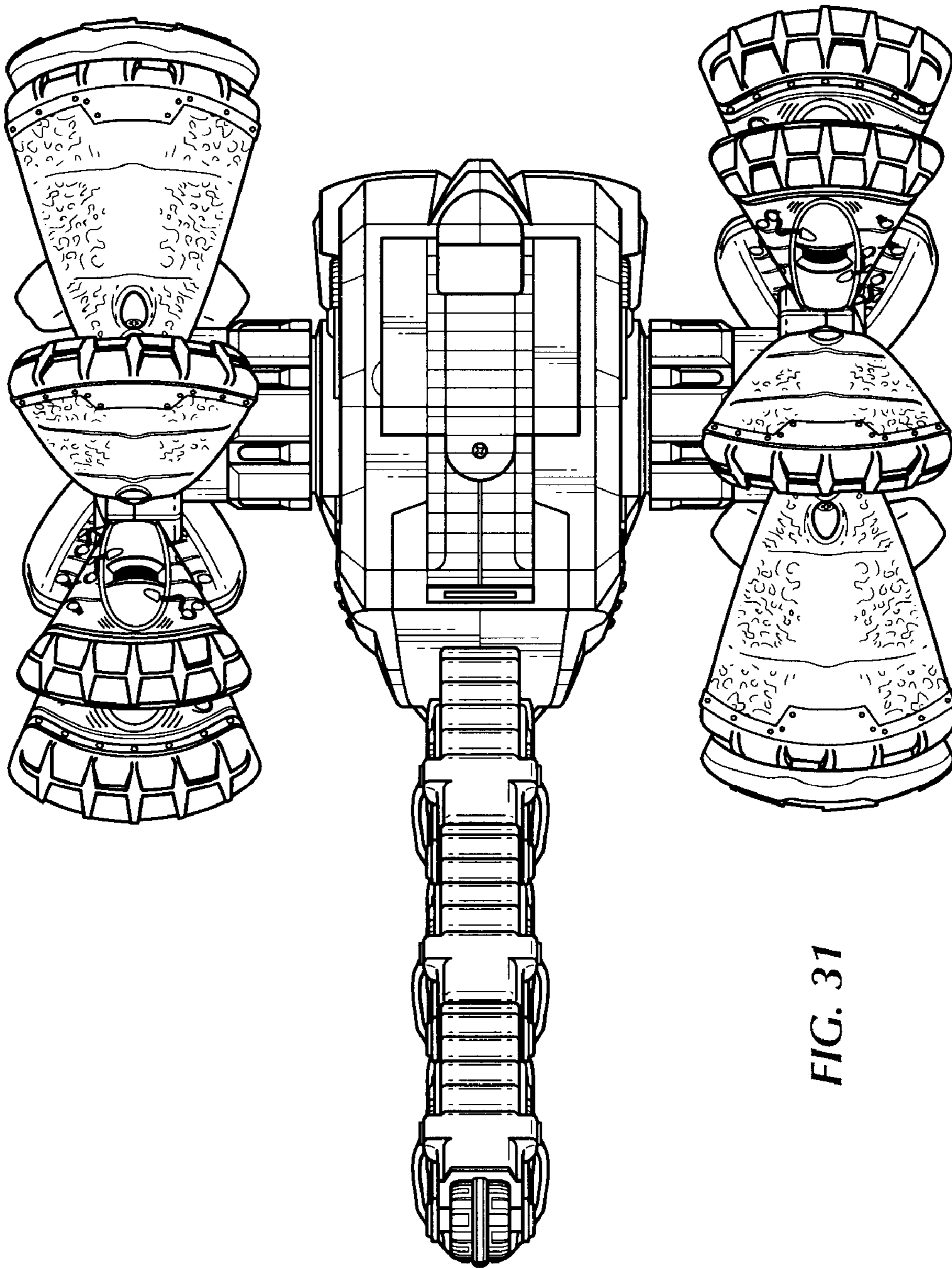

FIG. 31

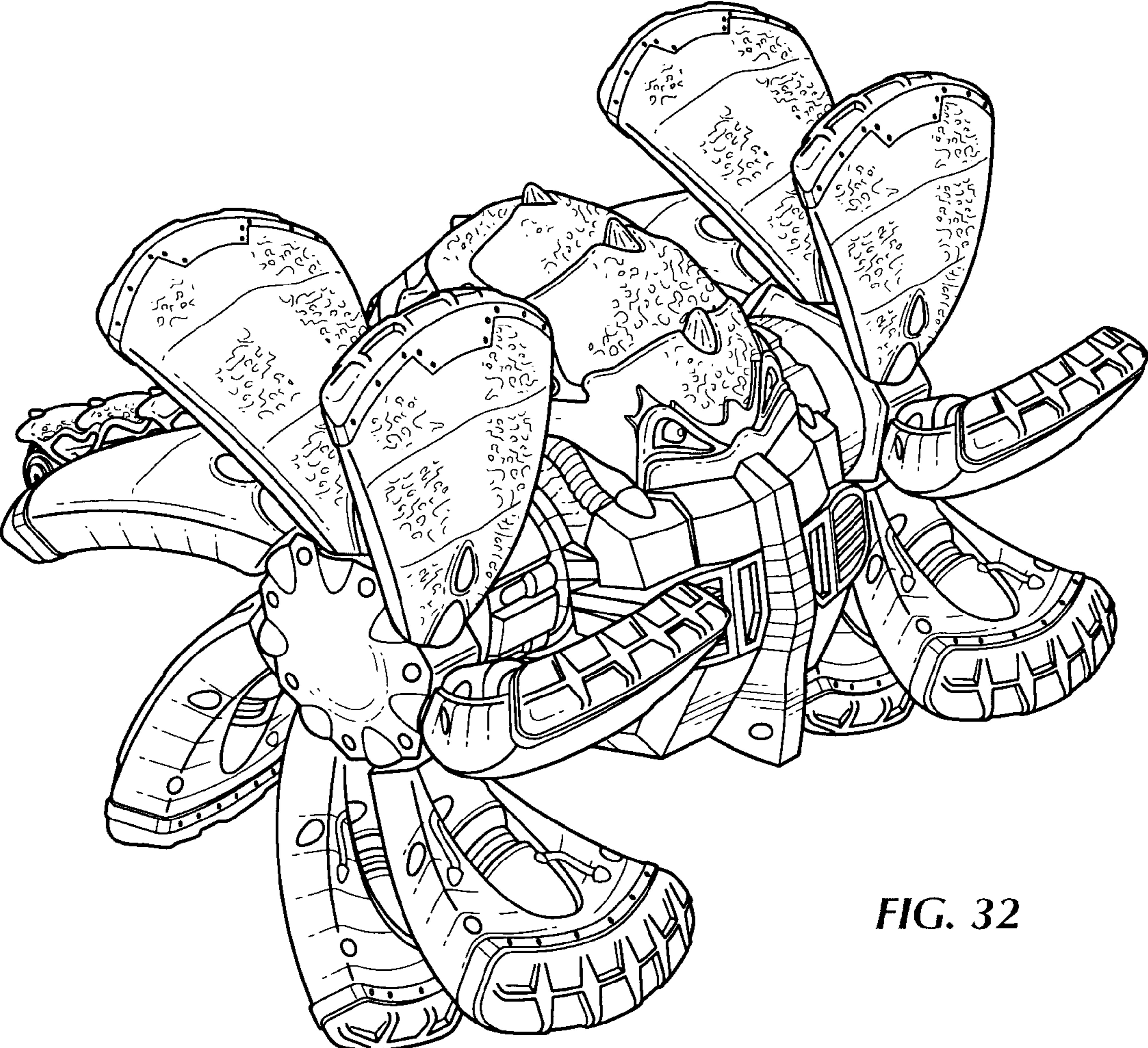

FIG. 32

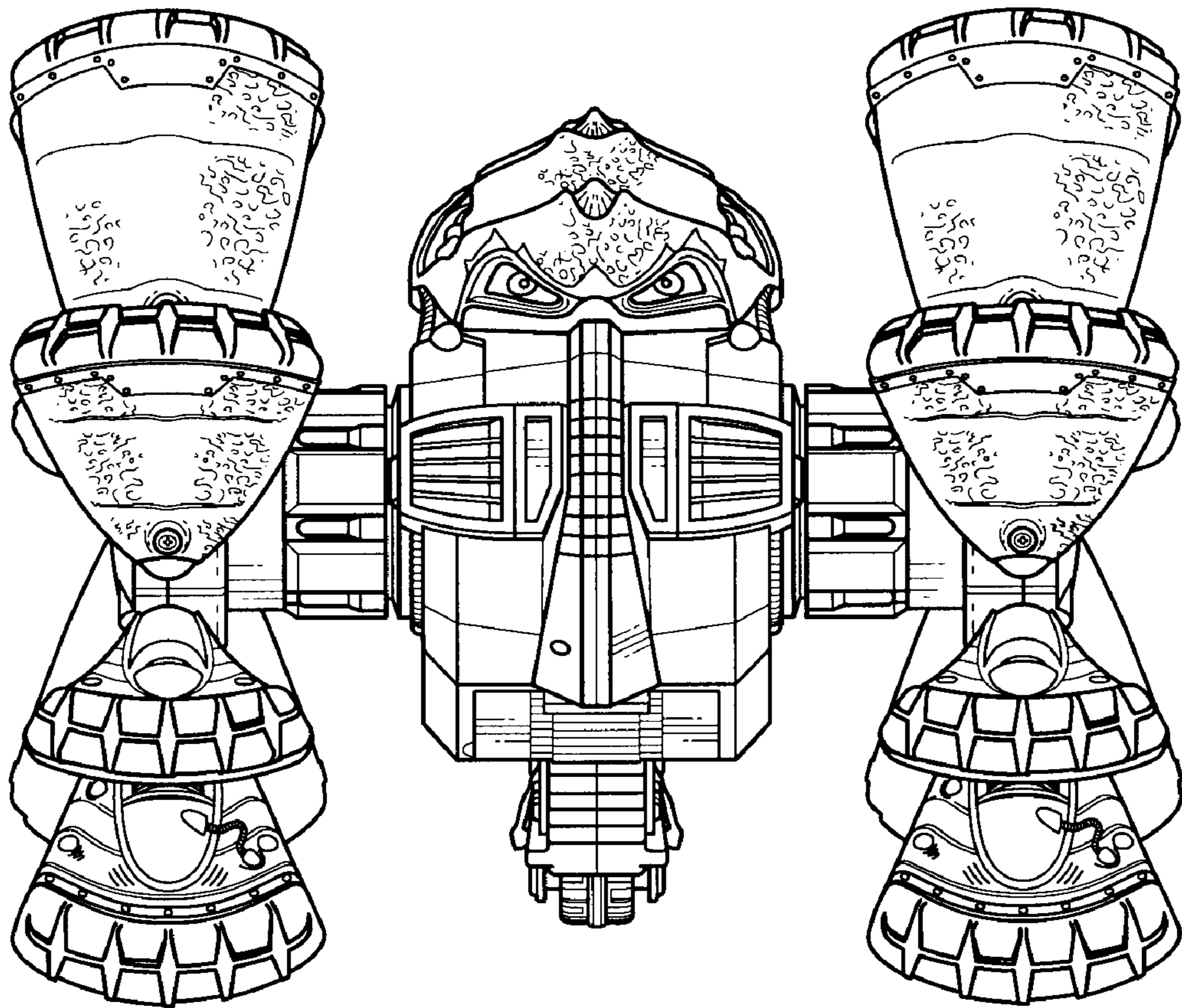

FIG. 33

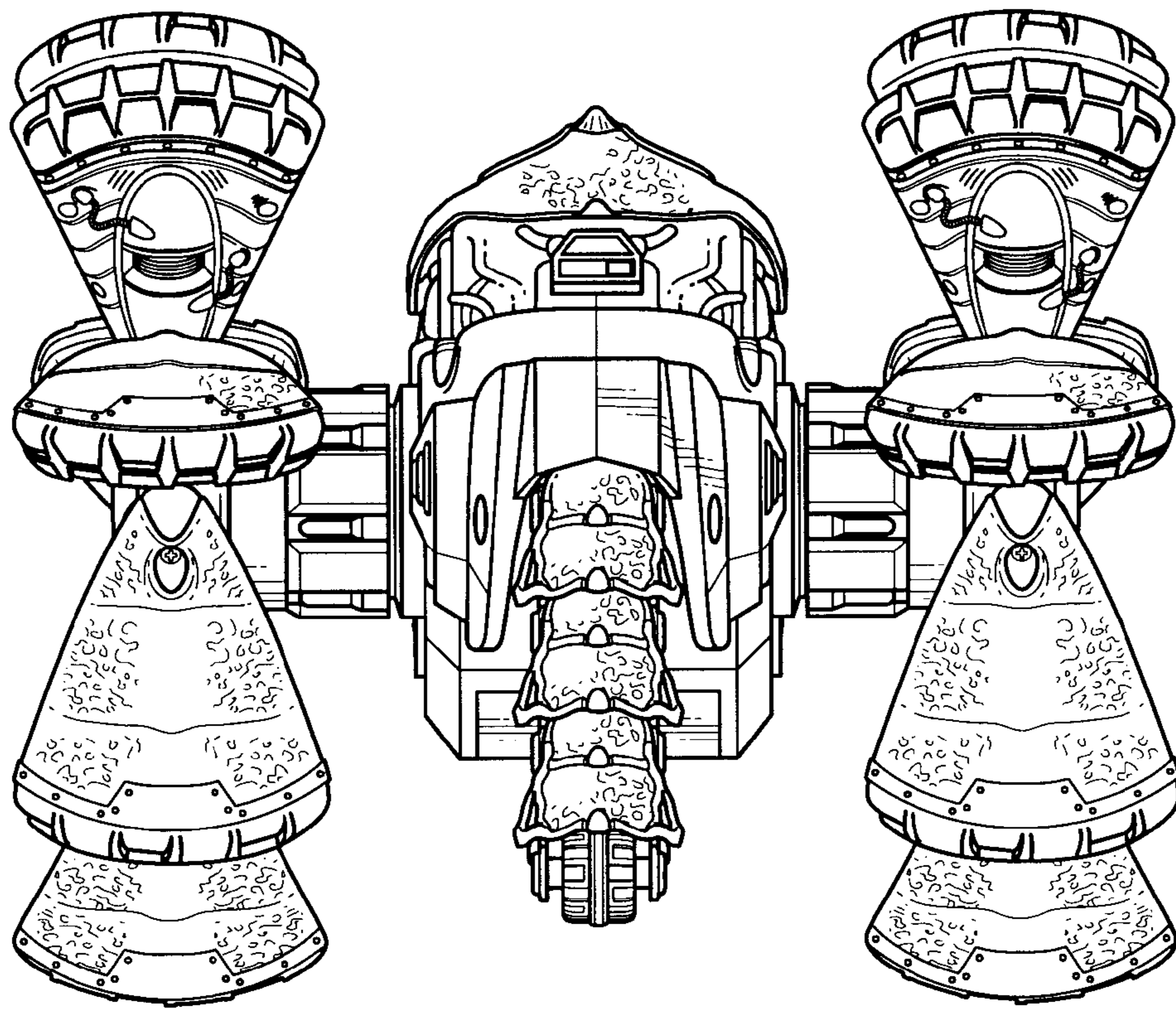

FIG. 34

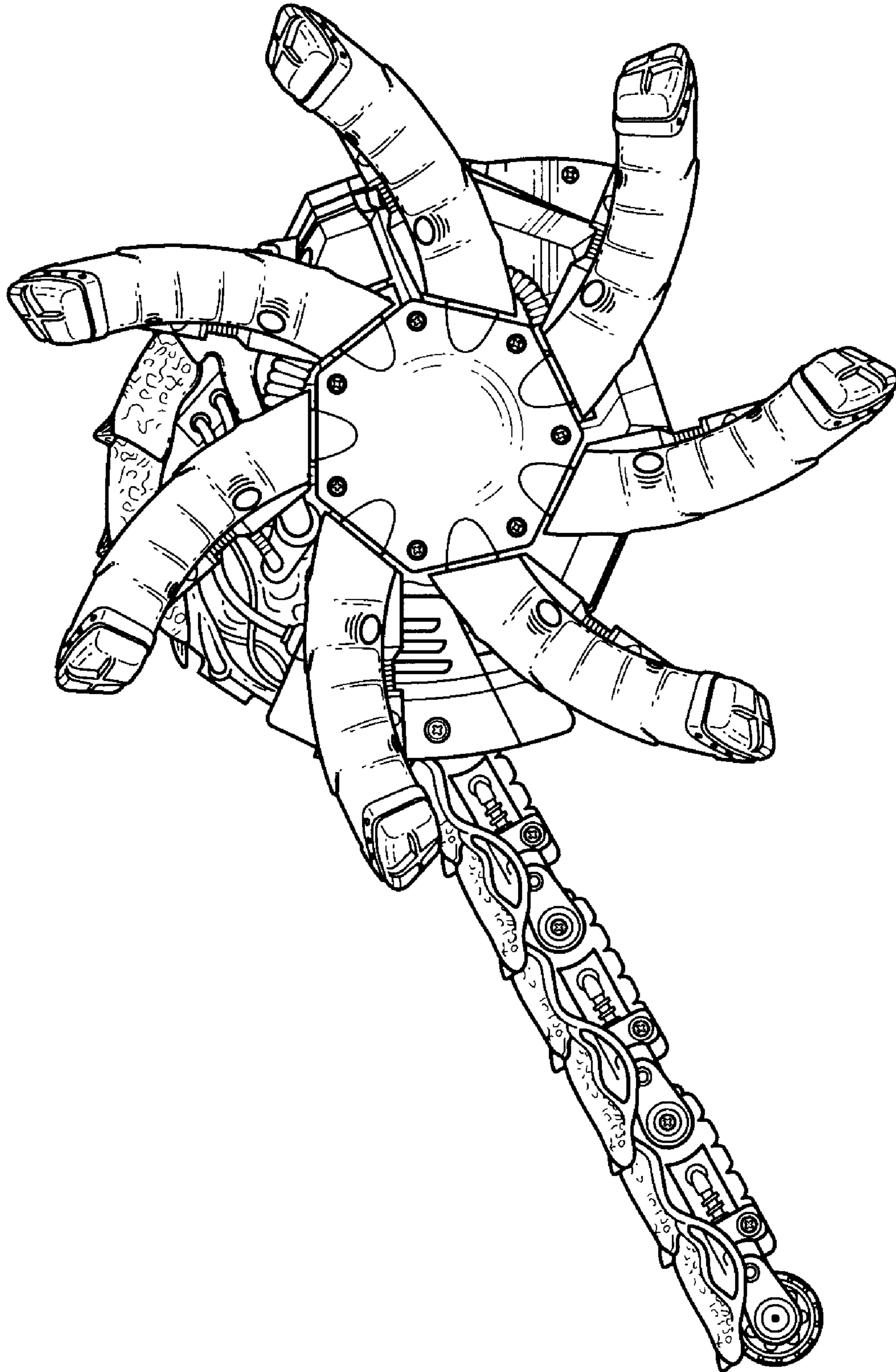

FIG. 35

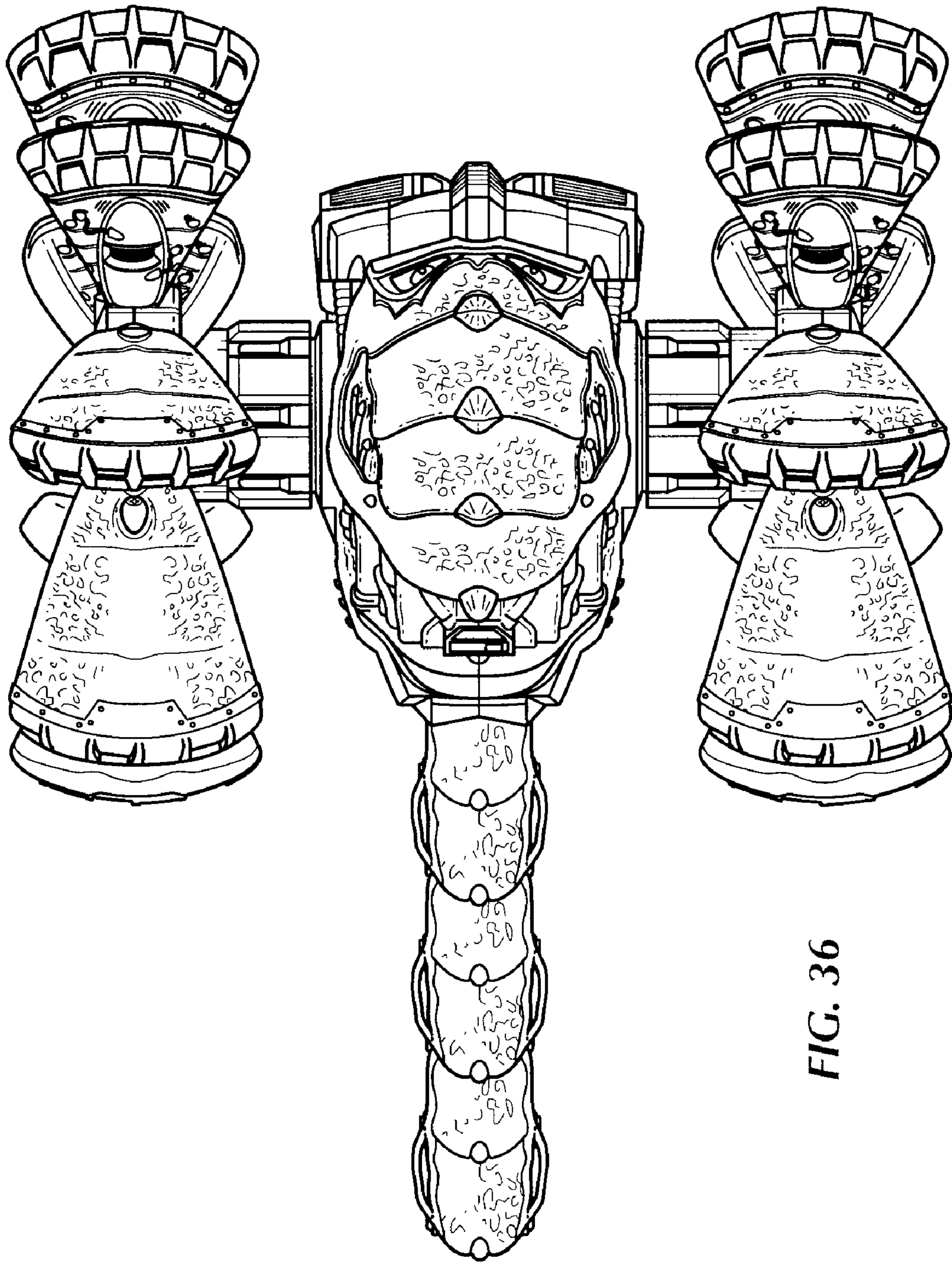

FIG. 36

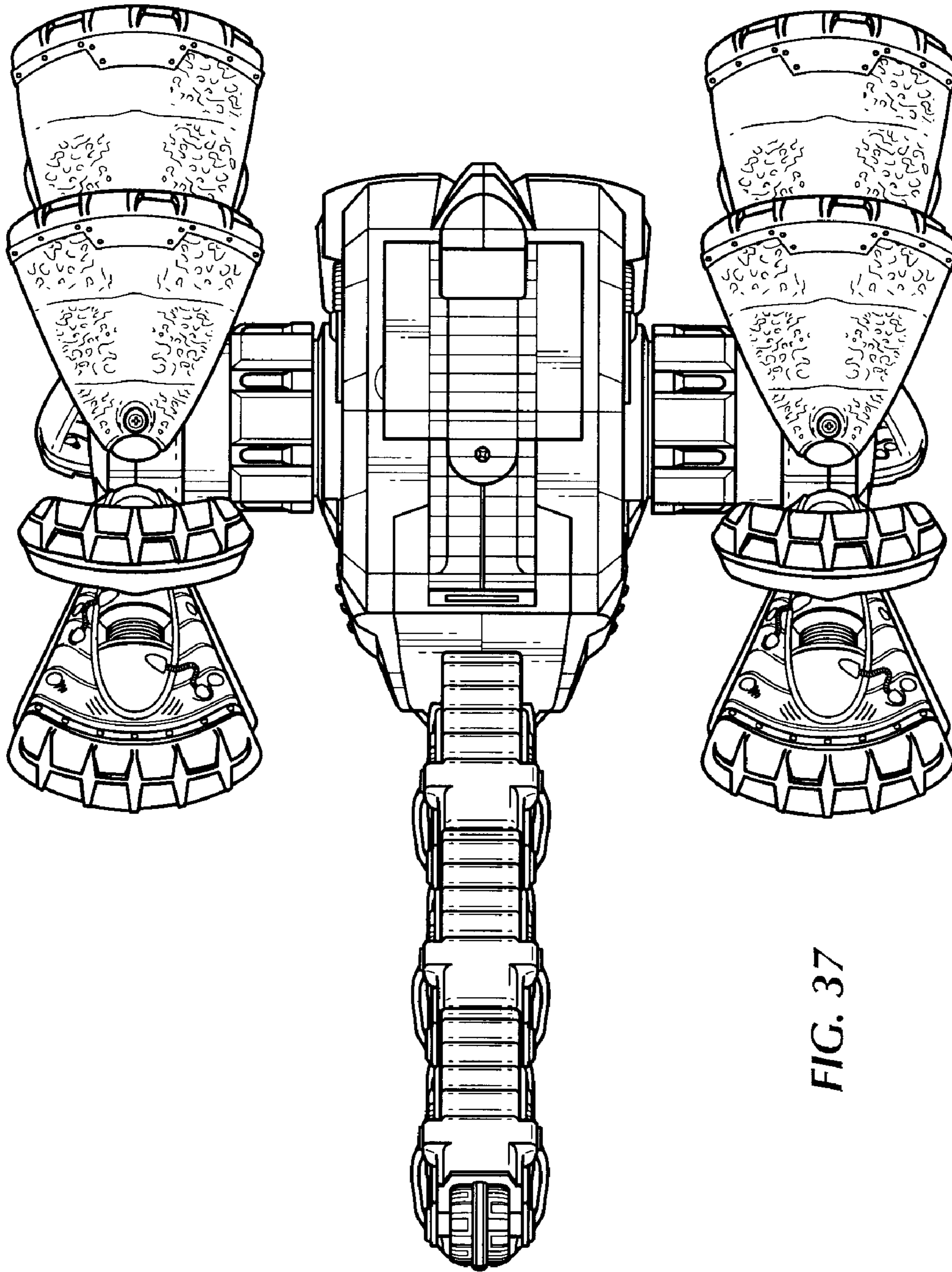

FIG. 37