



US00D529915S

(12) **United States Design Patent**
Scicluna et al.

(10) **Patent No.:** **US D529,915 S**

(45) **Date of Patent:** **** Oct. 10, 2006**

(54) **DISK DRIVE CARRIER**

(75) Inventors: **Mark Scicluna**, Long Sutton (GB);
Adam Wade, Rowlands Castle (GB)

(73) Assignee: **Xyratec Technology Limited**,
Hampshire (GB)

(**) Term: **14 Years**

(21) Appl. No.: **29/212,134**

(22) Filed: **Aug. 27, 2004**

(30) **Foreign Application Priority Data**

Mar. 15, 2004 (EM) 156765

(51) **LOC (8) Cl.** **14-02**

(52) **U.S. Cl.** **D14/439**

(58) **Field of Classification Search** D14/348,
D14/356, 361-369, 301, 439; D13/162, 184,
D13/199; 312/223.3; 360/99.01-99.12, 98.01;
361/680-686, 690-697; 369/34.01, 36.01

See application file for complete search history.

(56) **References Cited**

U.S. PATENT DOCUMENTS

D322,965 S	*	1/1992	Silverstein et al.	D14/367
5,175,657 A	*	12/1992	Ifikar et al.	360/98.01
6,088,221 A	*	7/2000	Bologna	361/685
D455,422 S	*	4/2002	Bath	D14/301
6,373,695 B1	*	4/2002	Cheng	361/685
6,400,568 B1	*	6/2002	Kim et al.	361/697
6,556,432 B1	*	4/2003	Chen et al.	361/685
D484,508 S	*	12/2003	Crippen et al.	D14/439
D493,462 S	*	7/2004	Wang	D14/366

* cited by examiner

Primary Examiner—Freda S. Nunn

(74) *Attorney, Agent, or Firm*—Pillsbury Winthrop Shaw Pittman, LLP

(57) **CLAIM**

The ornamental design of a disk drive carrier, as shown and described.

DESCRIPTION

FIG. 1 is a perspective view of the disk drive carrier according to a first embodiment of our design.

FIG. 2 is a plan view from above of the disk drive carrier according to the first embodiment.

FIG. 3 is a plan view from below of the disk drive carrier according to the first embodiment.

FIG. 4 is an elevation of one end of the disk drive carrier according to the first embodiment.

FIG. 5 is an elevation of one side of the disk drive carrier according to the first embodiment.

FIG. 6 is an elevation of the other side of the disk drive carrier according to the first embodiment.

FIG. 7 is a perspective view of the disk drive carrier according to a second embodiment of our design.

FIG. 8 is a plan view from above according to the second embodiment.

FIG. 9 is a plan view from below according to the second embodiment.

FIG. 10 is an elevation of one end according to the second embodiment.

FIG. 11 is an elevation of one side according to the second embodiment; and,

FIG. 12 is an elevation of the other side according to the second embodiment.

1 Claim, 4 Drawing Sheets

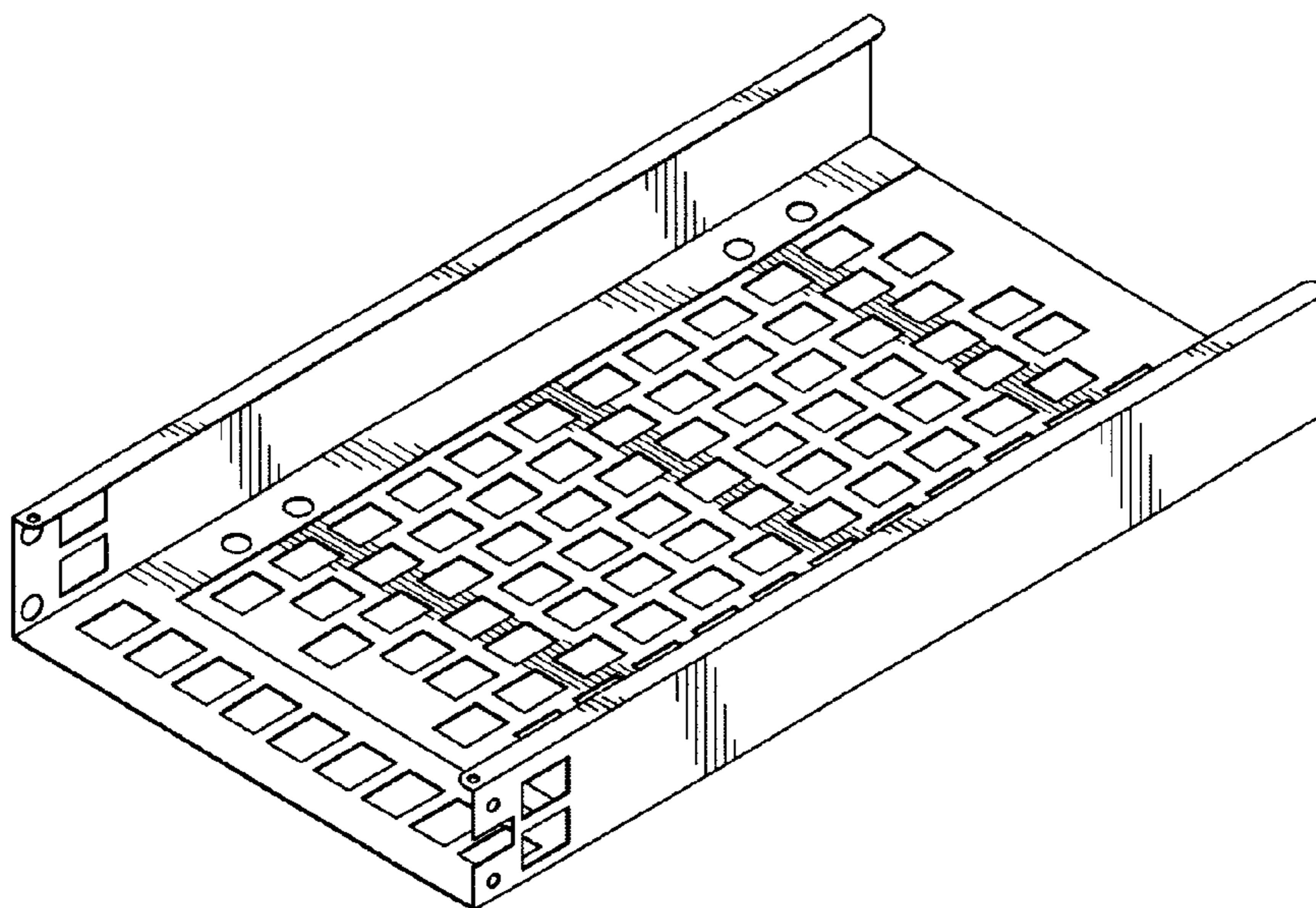

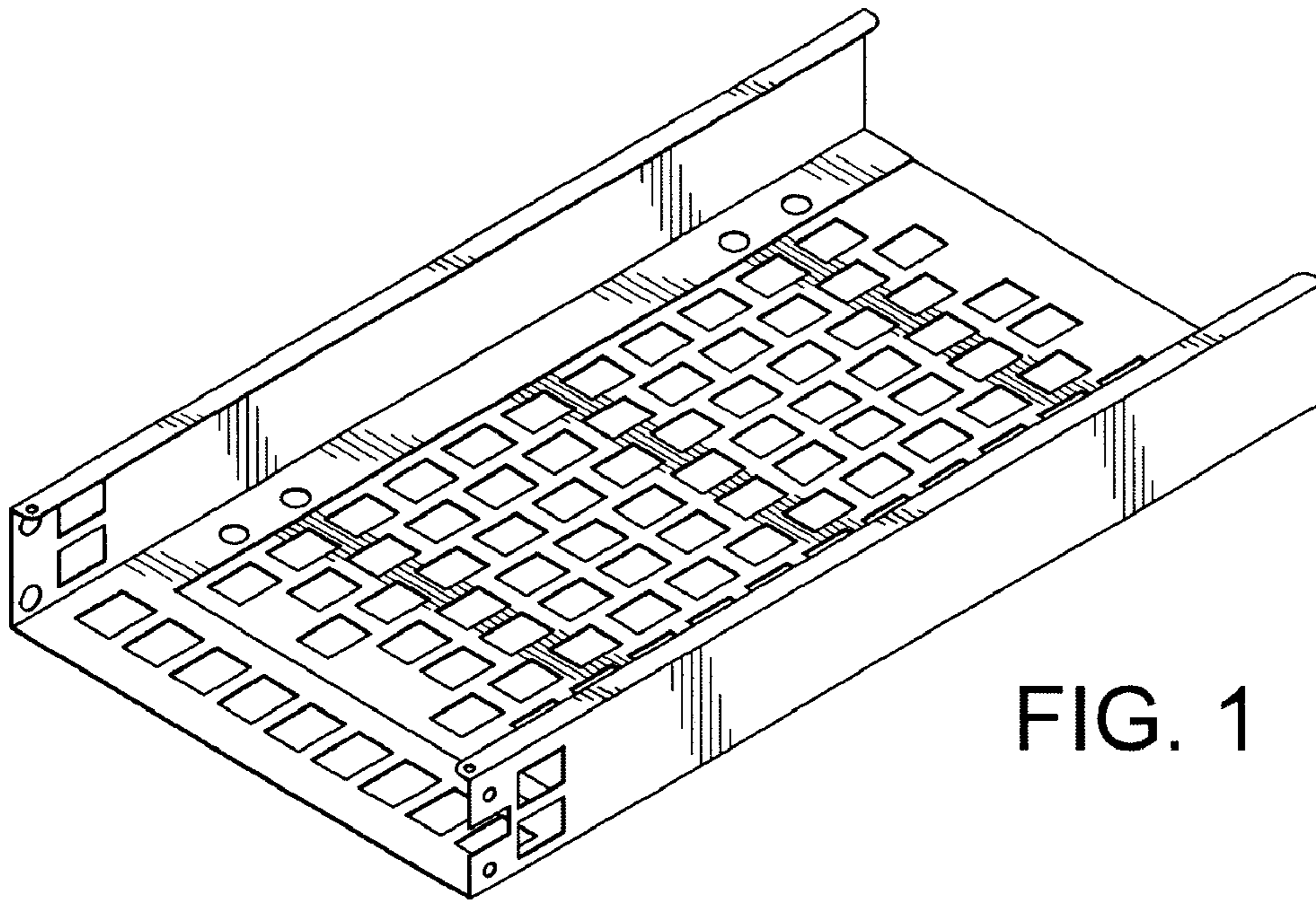

FIG. 1

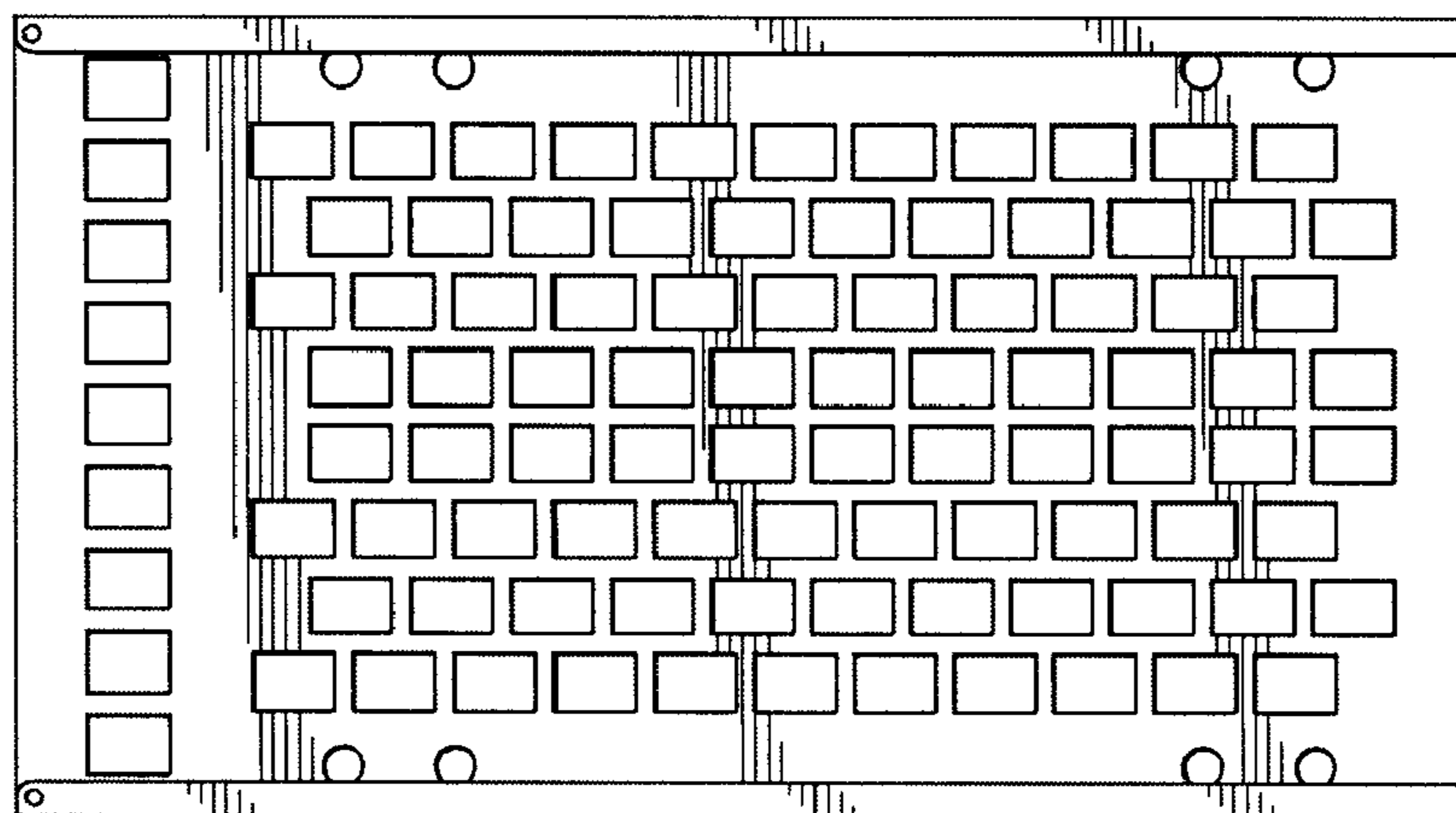

FIG. 2

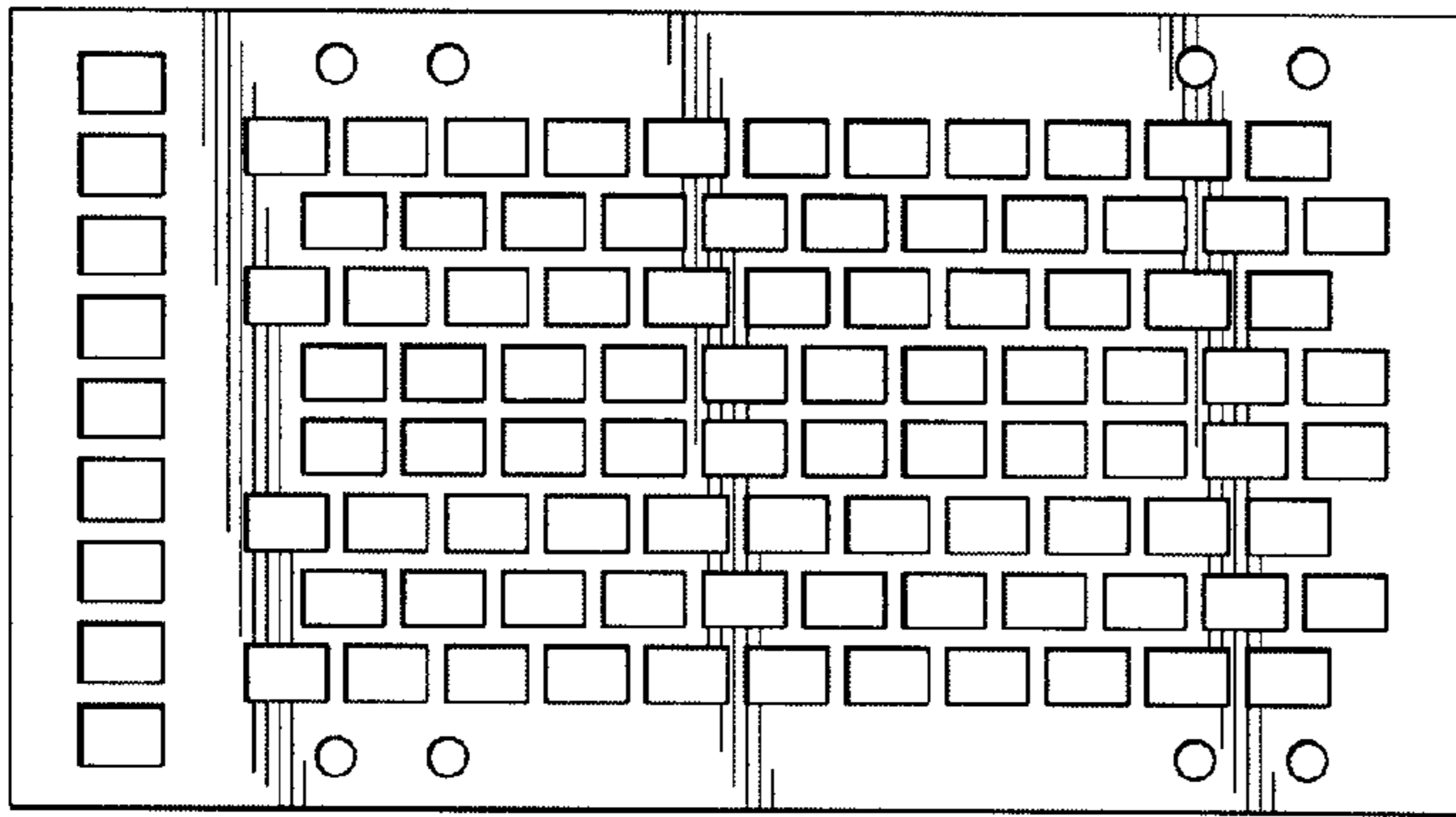

FIG. 3



FIG. 4



FIG. 5



FIG. 6

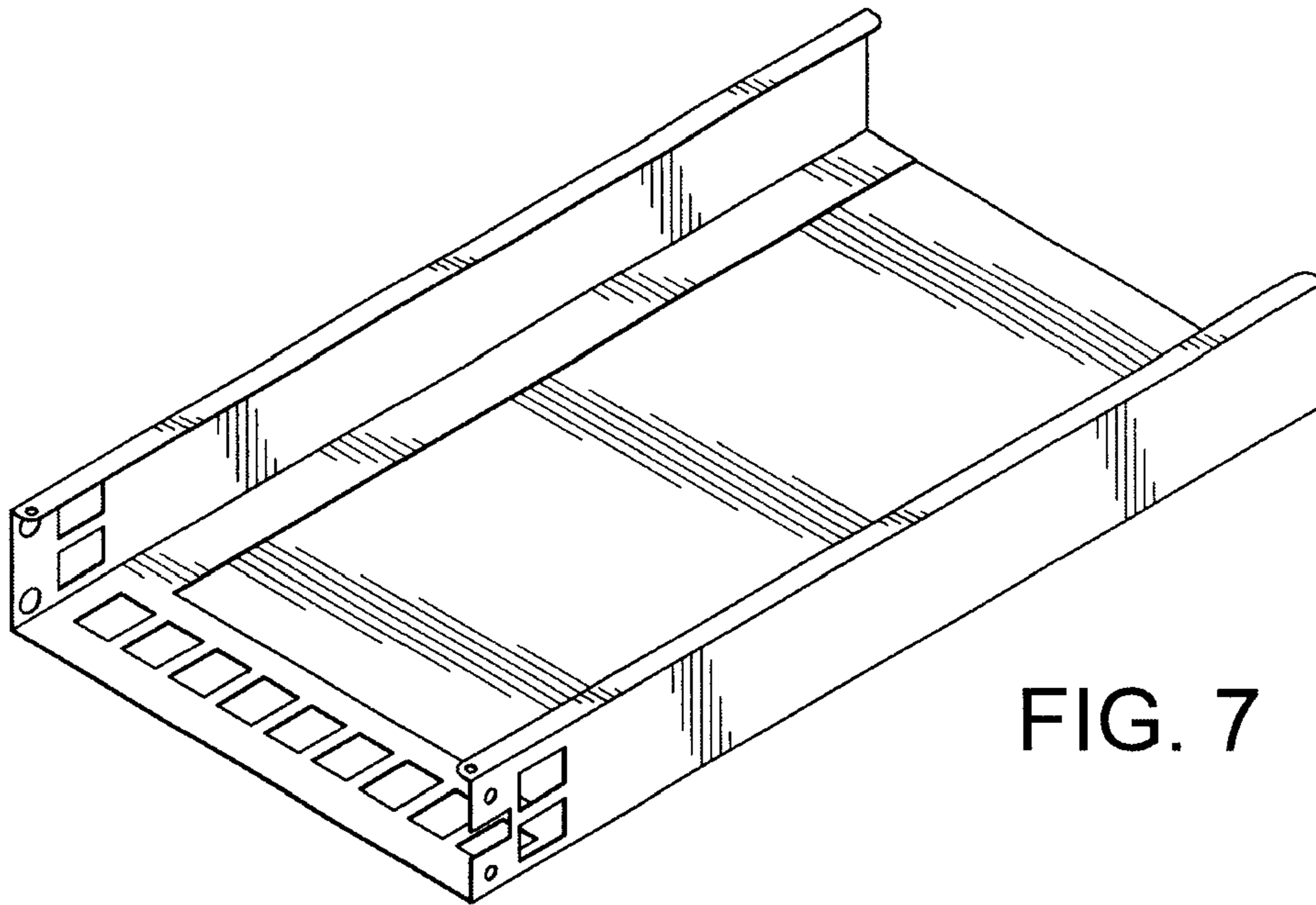

FIG. 7

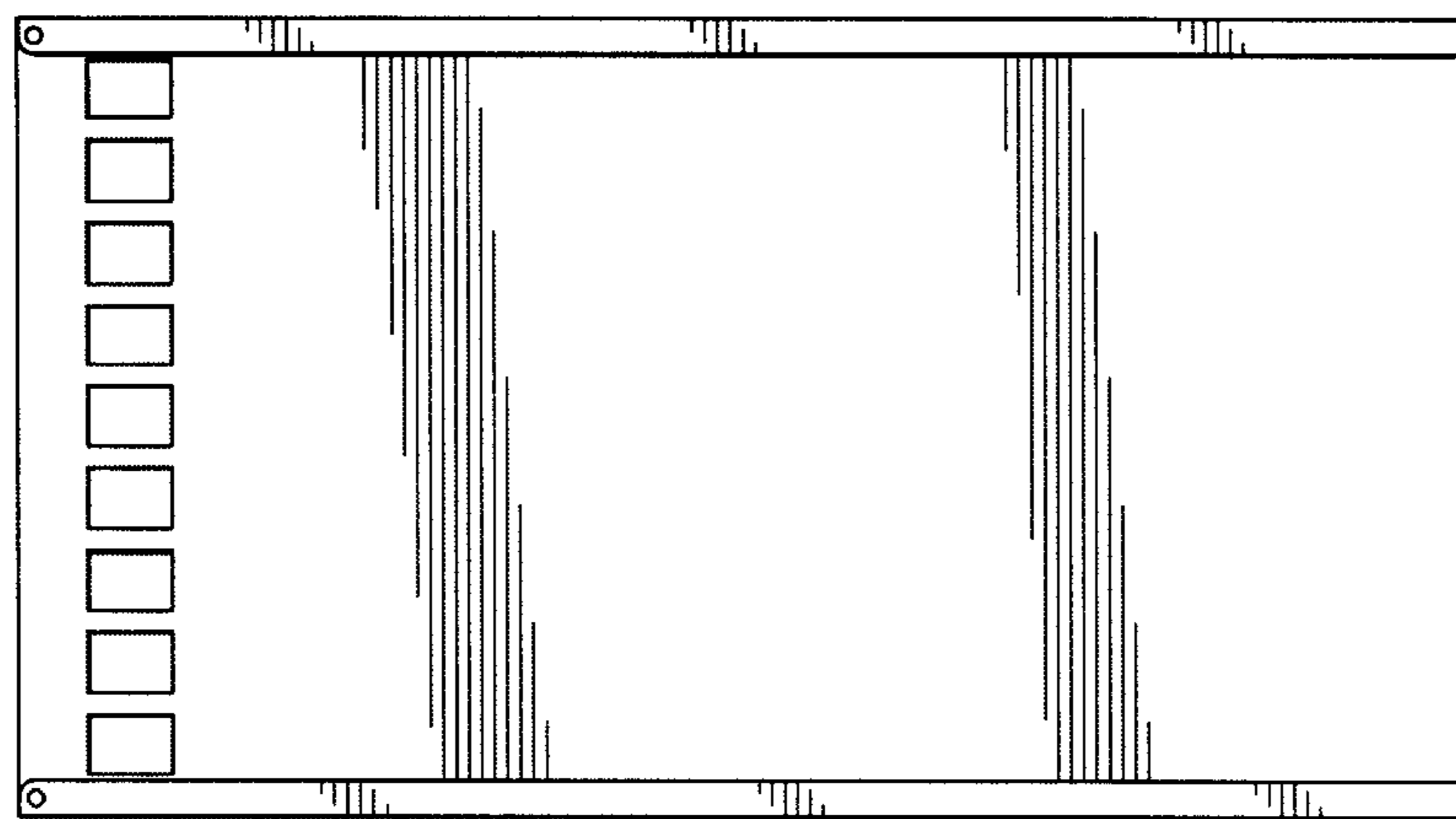

FIG. 8

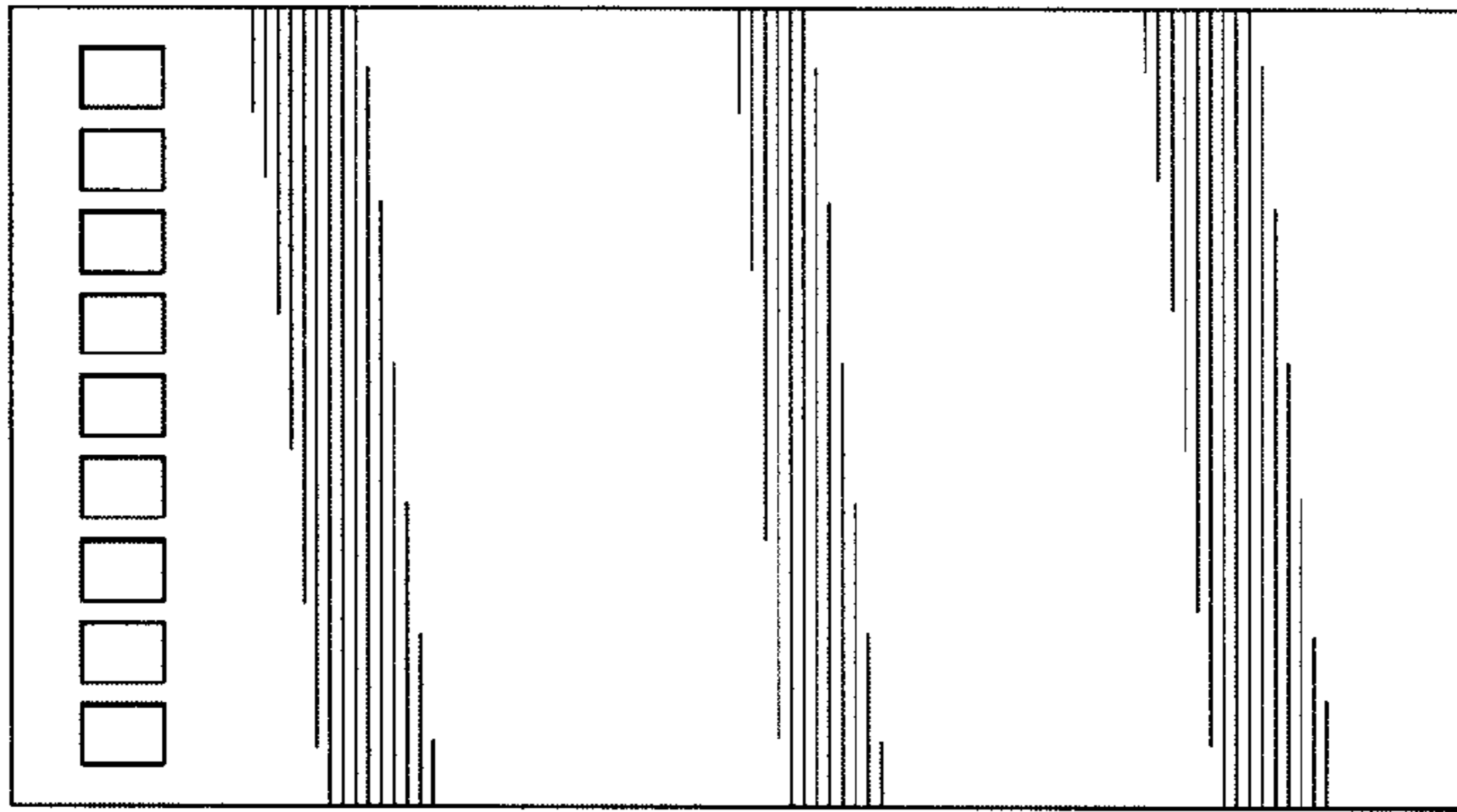

FIG. 9



FIG. 10



FIG. 11



FIG. 12