



US00D529570S

(12) **United States Design Patent**
Peterson

(10) **Patent No.:** **US D529,570 S**

(45) **Date of Patent:** **** Oct. 3, 2006**

(54) **INFLATABLE TOWABLE WATER KITE**

D480,123 S * 9/2003 Peterson D21/803
D504,045 S * 4/2005 Rediske D6/601

(75) Inventor: **Leroy L. Peterson**, Omaha, NE (US)

OTHER PUBLICATIONS

(73) Assignee: **Sportsstuff, Inc.**, Omaha, NE (US)

Overton's Catalog, Edition #3, Mar. 2000, p. 243, 'Two-Person Steerable Airhead Slash and the Airhead Rip', located in the center of page.*

(**) Term: **14 Years**

Overton's Catalog 1998, p. 59, 'Wake Jet', located at the bottom of the page.*

(21) Appl. No.: **29/244,912**

Ski-Limited Catalog 2003, p. 21, 'Shockwave Duo Tube' located at the bottom left of page.*

(22) Filed: **Dec. 15, 2005**

(51) **LOC (8) Cl.** **21-02**

* cited by examiner

(52) **U.S. Cl.** **D21/809**; D21/803

Primary Examiner—Caron D. Veynar

(58) **Field of Classification Search** D21/769-770,
D21/801, 803, 809; D6/392, 596, 601, 604;
472/128-129; D12/5, 6, 316; 114/253, 345-346;
441/35, 66, 40-42, 129-132

Assistant Examiner—Zenita I. Bennett

See application file for complete search history.

(74) *Attorney, Agent, or Firm*—Sturm & Fix LLP

(56) **References Cited**

(57) **CLAIM**

The ornamental design for an inflatable towable water kite, as shown and described.

U.S. PATENT DOCUMENTS

DESCRIPTION

4,932,912	A	*	6/1990	Combs	441/129
4,942,839	A	*	7/1990	Chuan	114/345
5,360,360	A	*	11/1994	Peterson	441/130
5,713,294	A	*	2/1998	Wang	114/345
5,713,773	A	*	2/1998	Churchill	441/66
5,729,840	A	*	3/1998	Wu	4/588
D393,683	S	*	4/1998	Song et al.	D21/803
D426,097	S	*	6/2000	Bortolotto et al.	D6/604
6,394,868	B1	*	5/2002	Katz	441/130
D466,176	S	*	11/2002	Peterson	D21/803
D476,390	S	*	6/2003	Peterson	D21/803

FIG. 1 is a perspective view of the inflatable towable water kite showing my new design;
FIG. 2 is a top plan view thereof;
FIG. 3 is a right side elevational view thereof, the left side elevational view being a mirror image thereof;
FIG. 4 is a bottom plan view thereof;
FIG. 5 is a front elevational view thereof; and,
FIG. 6 is a rear elevational view thereof.

1 Claim, 3 Drawing Sheets

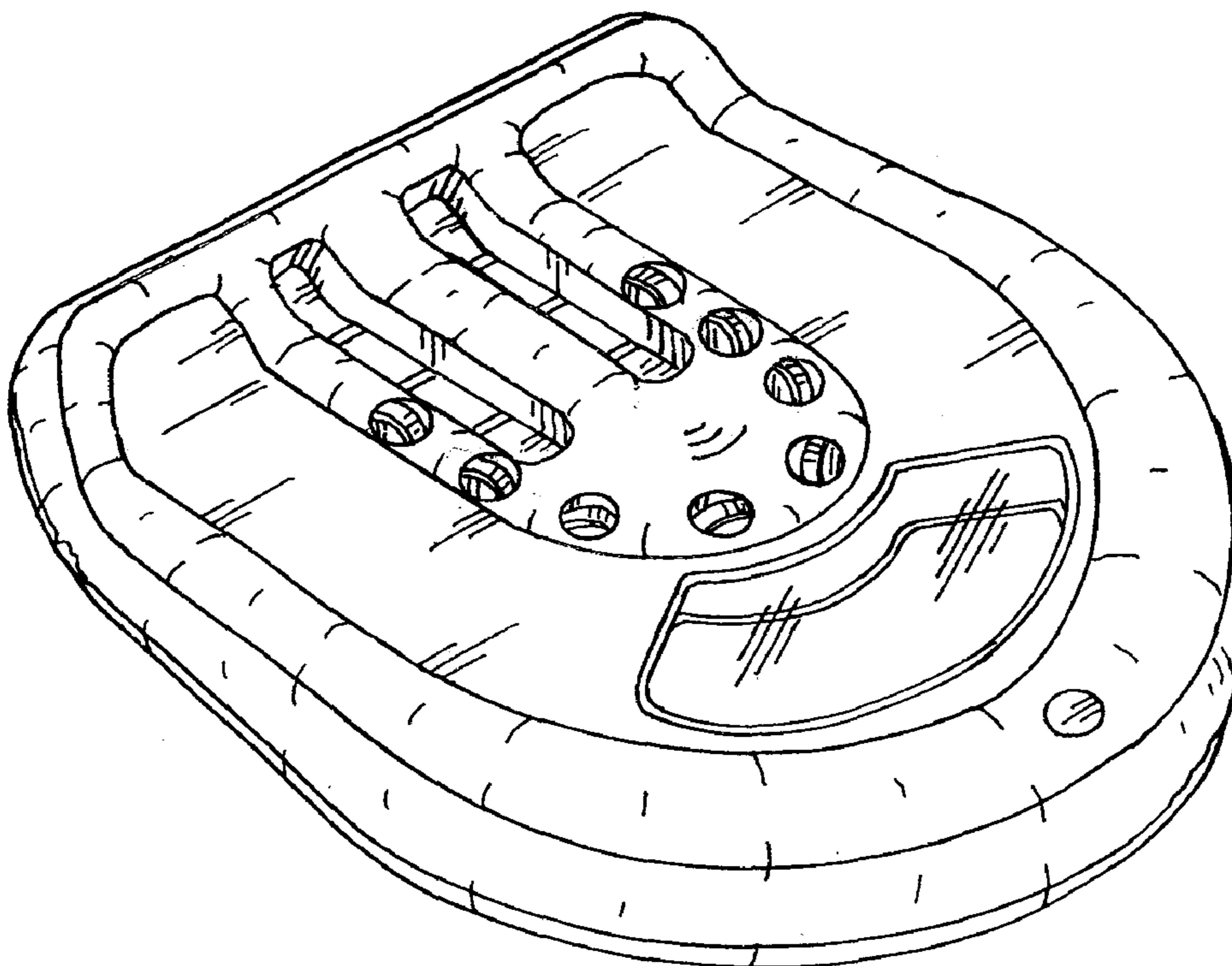

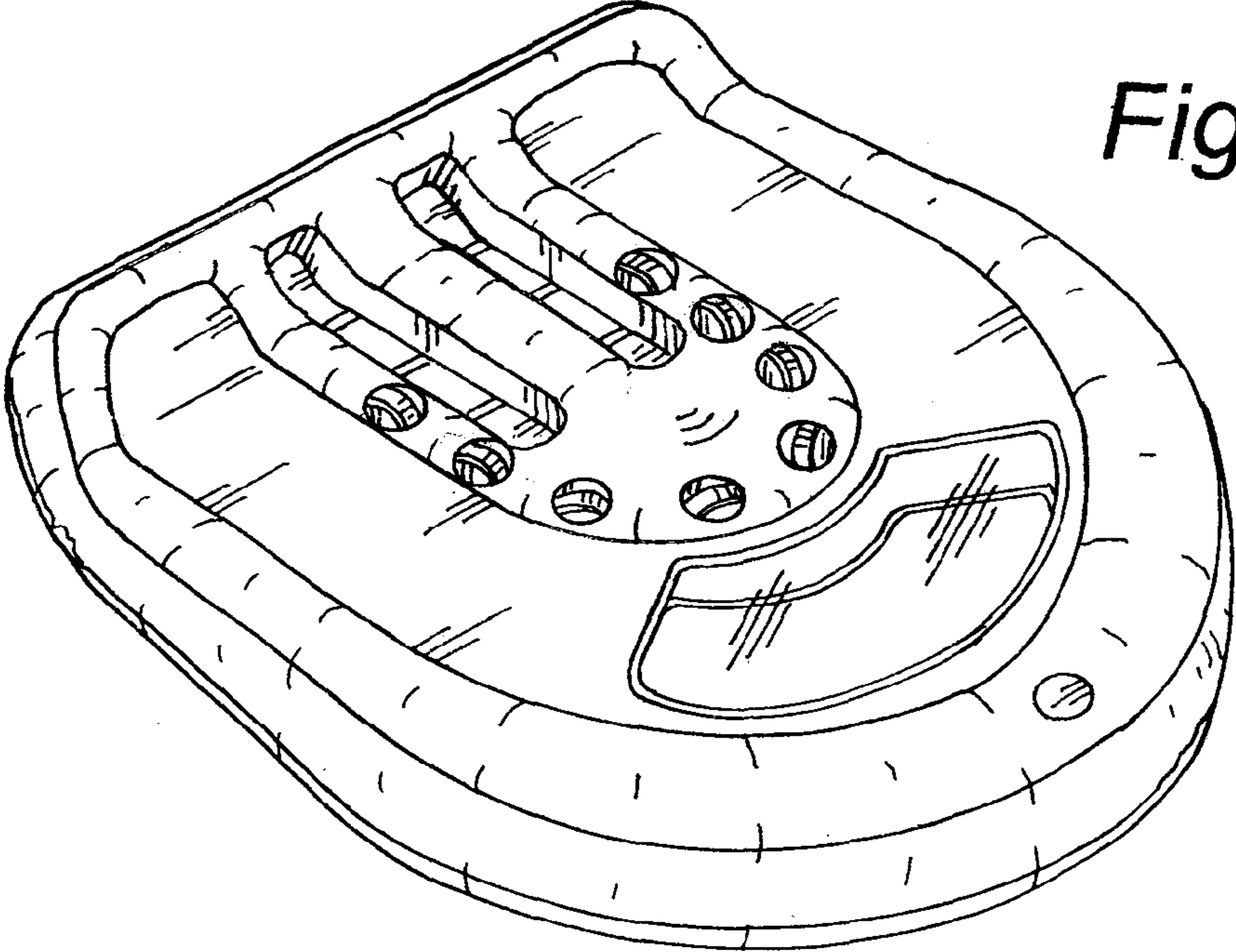

Fig. 1

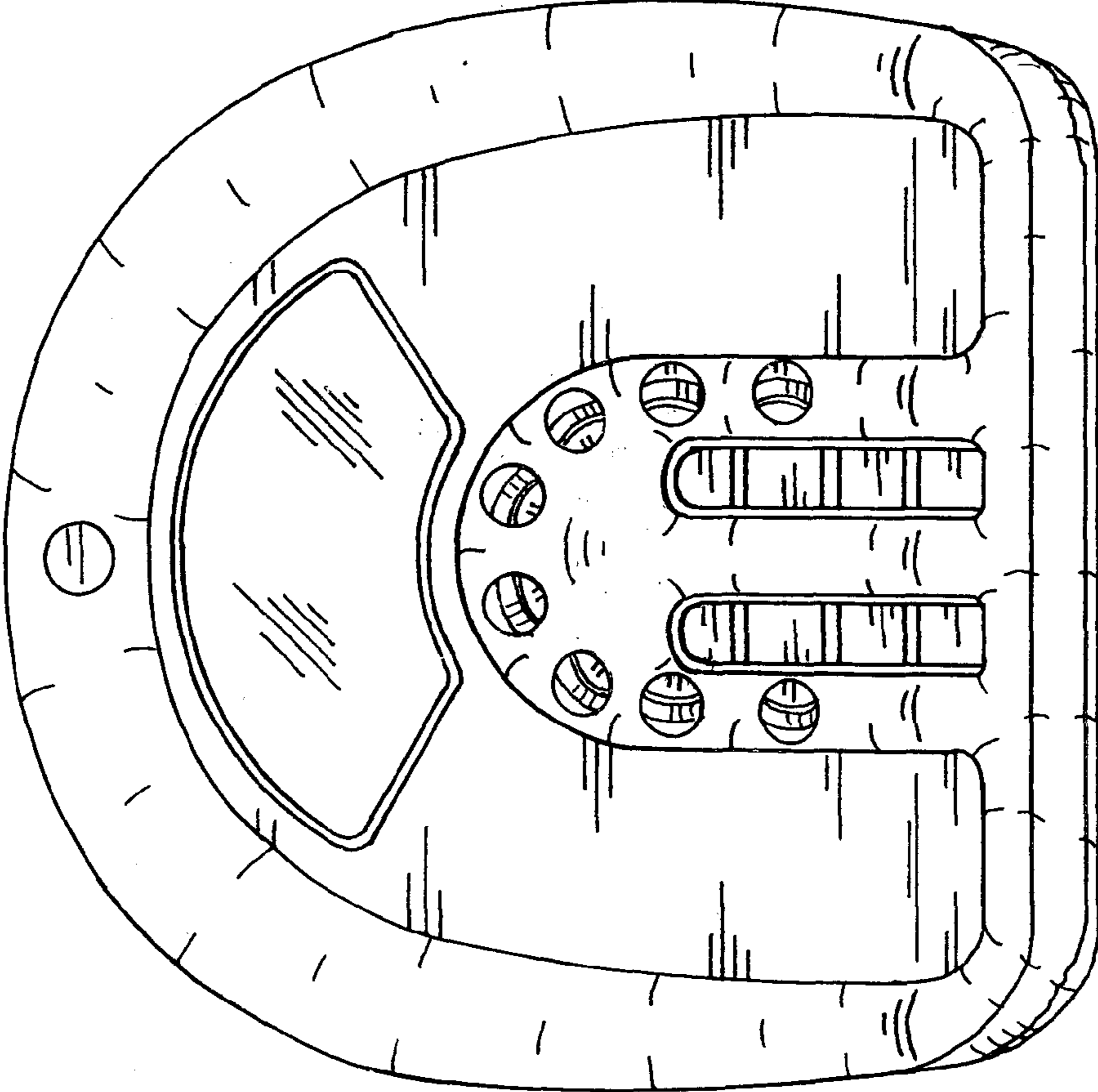

Fig. 2

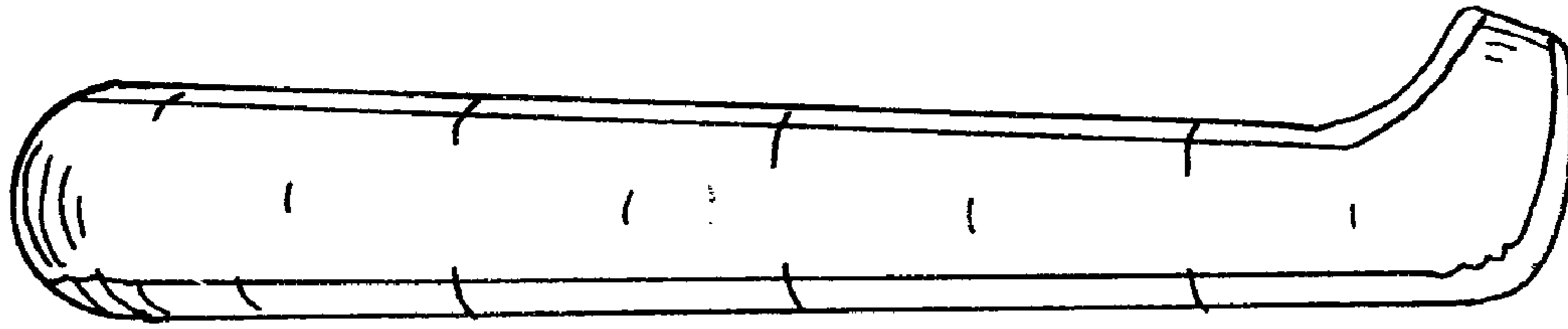

Fig. 3

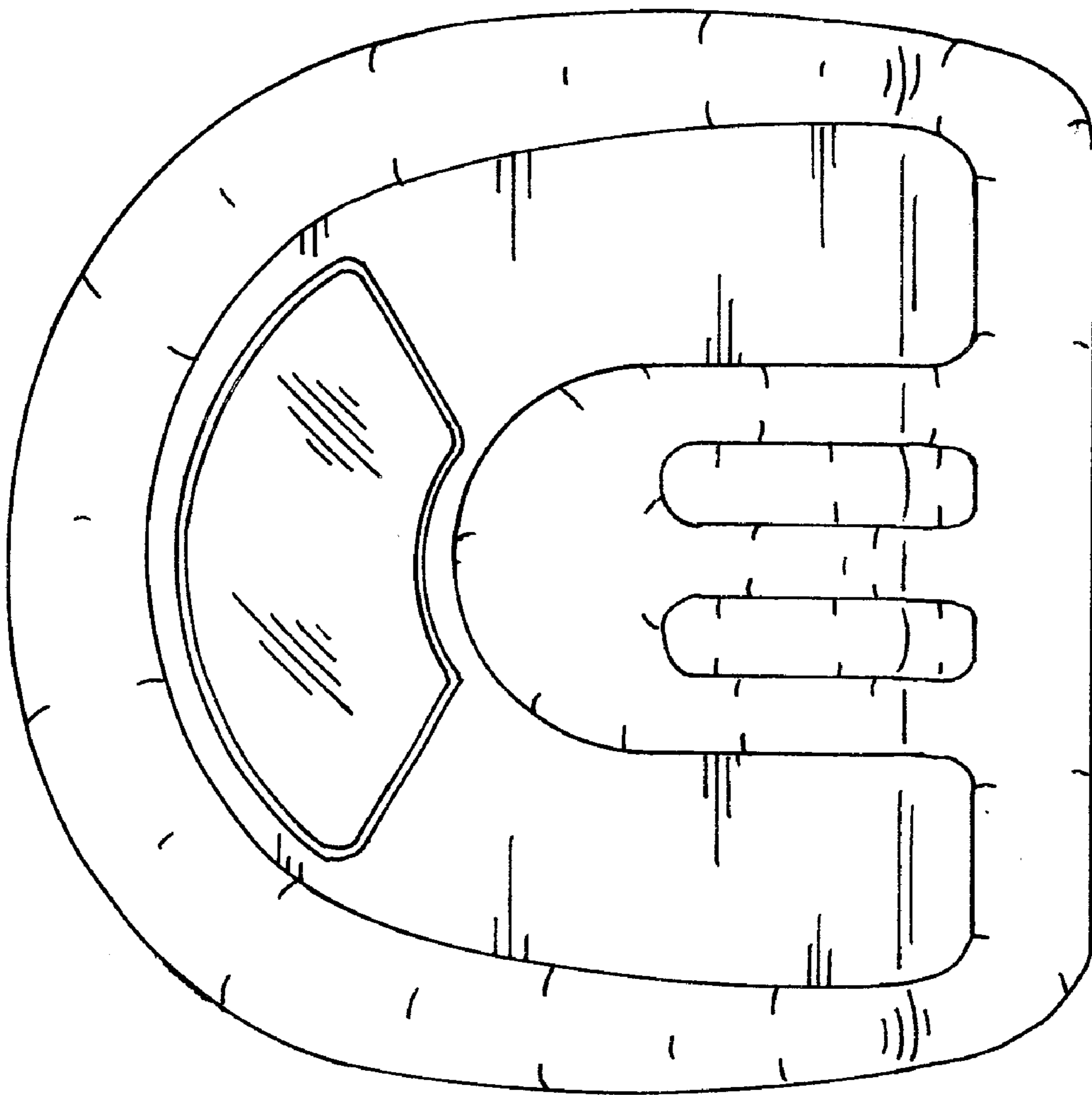

Fig. 4

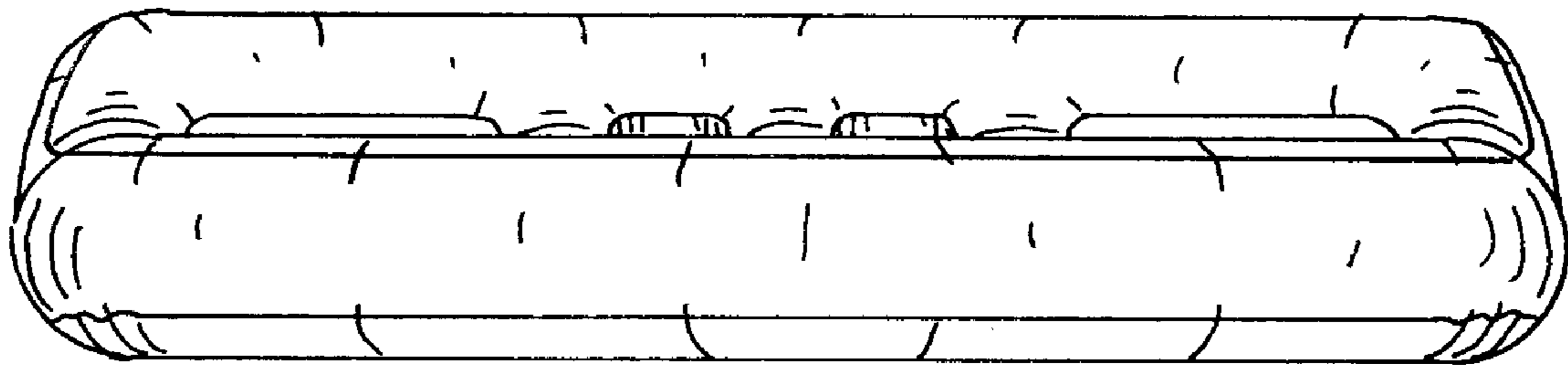

Fig. 5

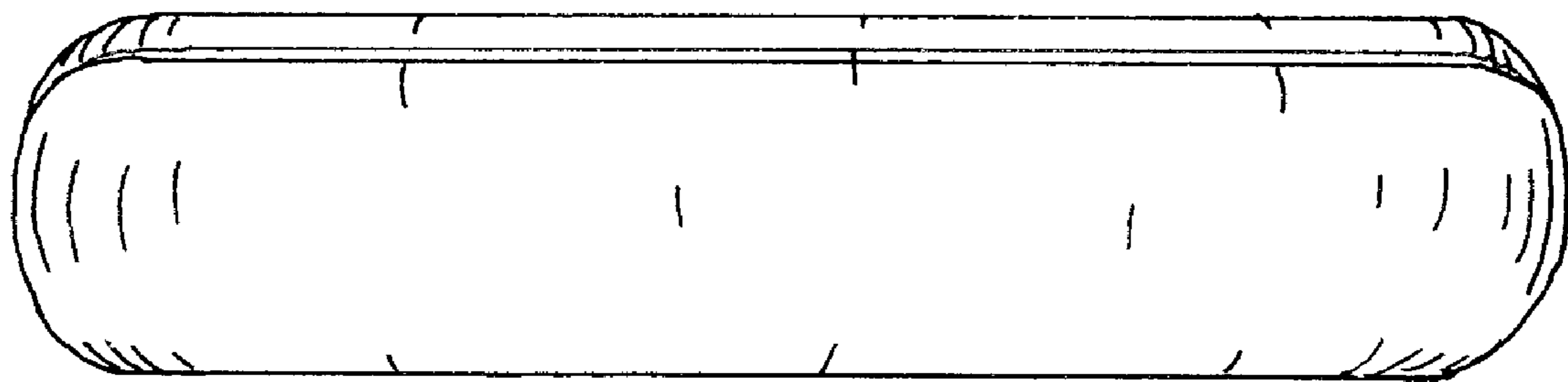

Fig. 6