



US00D529209S

(12) **United States Design Patent**  
**Ikeda**

(10) **Patent No.:** **US D529,209 S**  
(45) **Date of Patent:** **\*\* Sep. 26, 2006**

(54) **REAR COMBINATION LAMP FOR AN AUTOMOBILE**

D476,432 S \* 6/2003 Lin ..... D26/28  
D476,758 S \* 7/2003 Lin ..... D26/28  
D492,048 S \* 6/2004 Moisy et al. .... D26/28  
D509,311 S \* 9/2005 Tomida ..... D26/28

(75) Inventor: **Jiro Ikeda**, Wako (JP)

\* cited by examiner

(73) Assignee: **Honda Motor Co., Ltd.**, Tokyo (JP)

*Primary Examiner*—Marcus A. Jackson  
(74) *Attorney, Agent, or Firm*—Westerman, Hattori, Daniels & Adrian, LLP

(\*\*) Term: **14 Years**

(21) Appl. No.: **29/234,351**

(57) **CLAIM**

(22) Filed: **Jul. 18, 2005**

The ornamental design for, a rear combination lamp for an automobile, as shown and described.

(30) **Foreign Application Priority Data**

Jan. 19, 2005 (JP) ..... 2005-001202

**DESCRIPTION**

(51) **LOC (8) Cl.** ..... **26-06**

(52) **U.S. Cl.** ..... **D26/28**

(58) **Field of Classification Search** ..... D26/28-36;  
362/459-468, 475-478, 485-487

See application file for complete search history.

FIG. 1 is a front elevation view of a rear combination lamp for an automobile, showing our new design;  
FIG. 2 is a top plan view thereof;  
FIG. 3 is a right side elevation view thereof;  
FIG. 4 is a left side elevation view thereof; and,  
FIG. 5 is a perspective view thereof.

The broken lines in the drawings are illustrative purposes only and form no part of the claimed design.

(56) **References Cited**

**U.S. PATENT DOCUMENTS**

D472,657 S \* 4/2003 Pfeiffer et al. .... D26/28

**1 Claim, 3 Drawing Sheets**

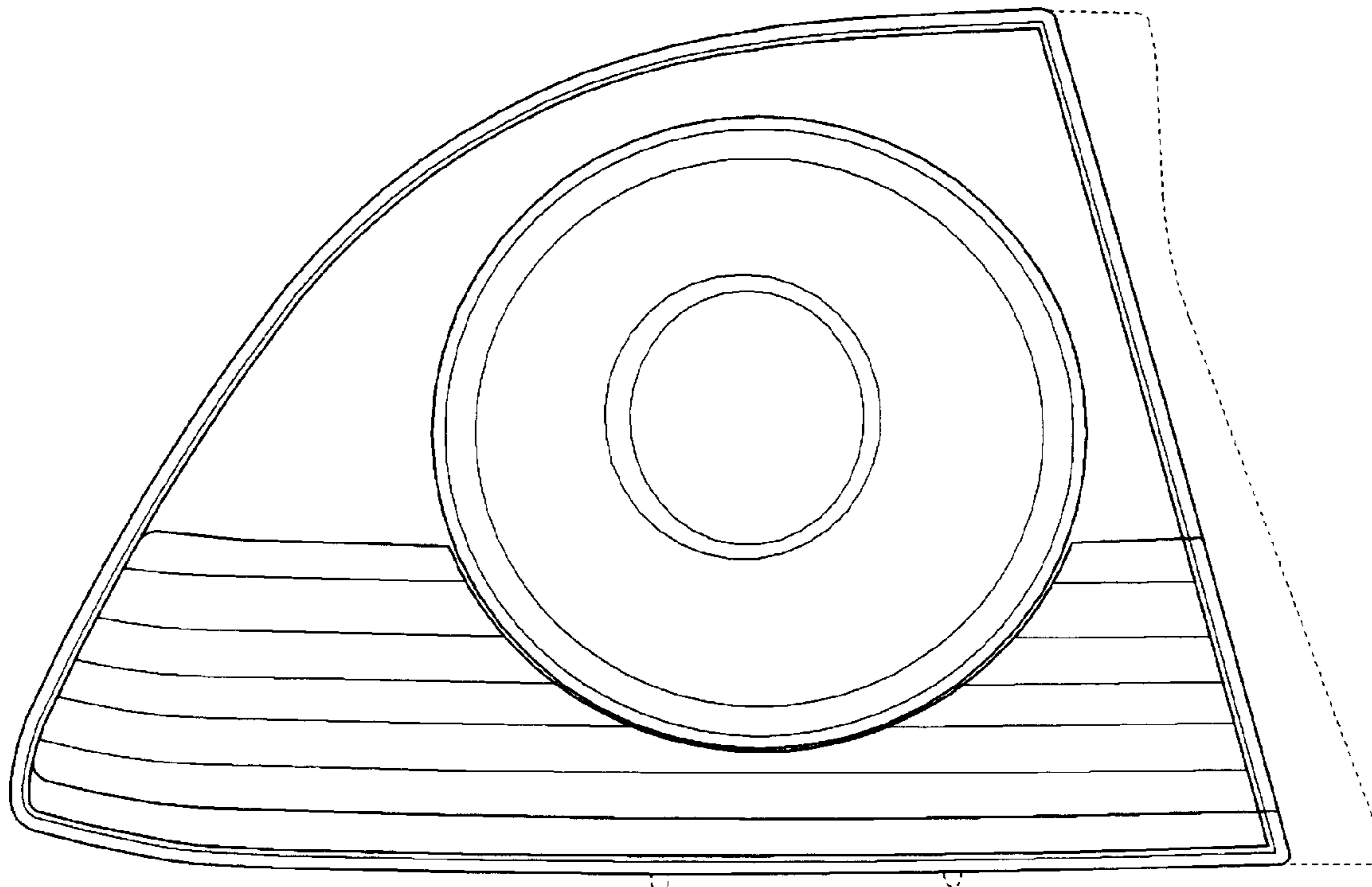

F I G. 1

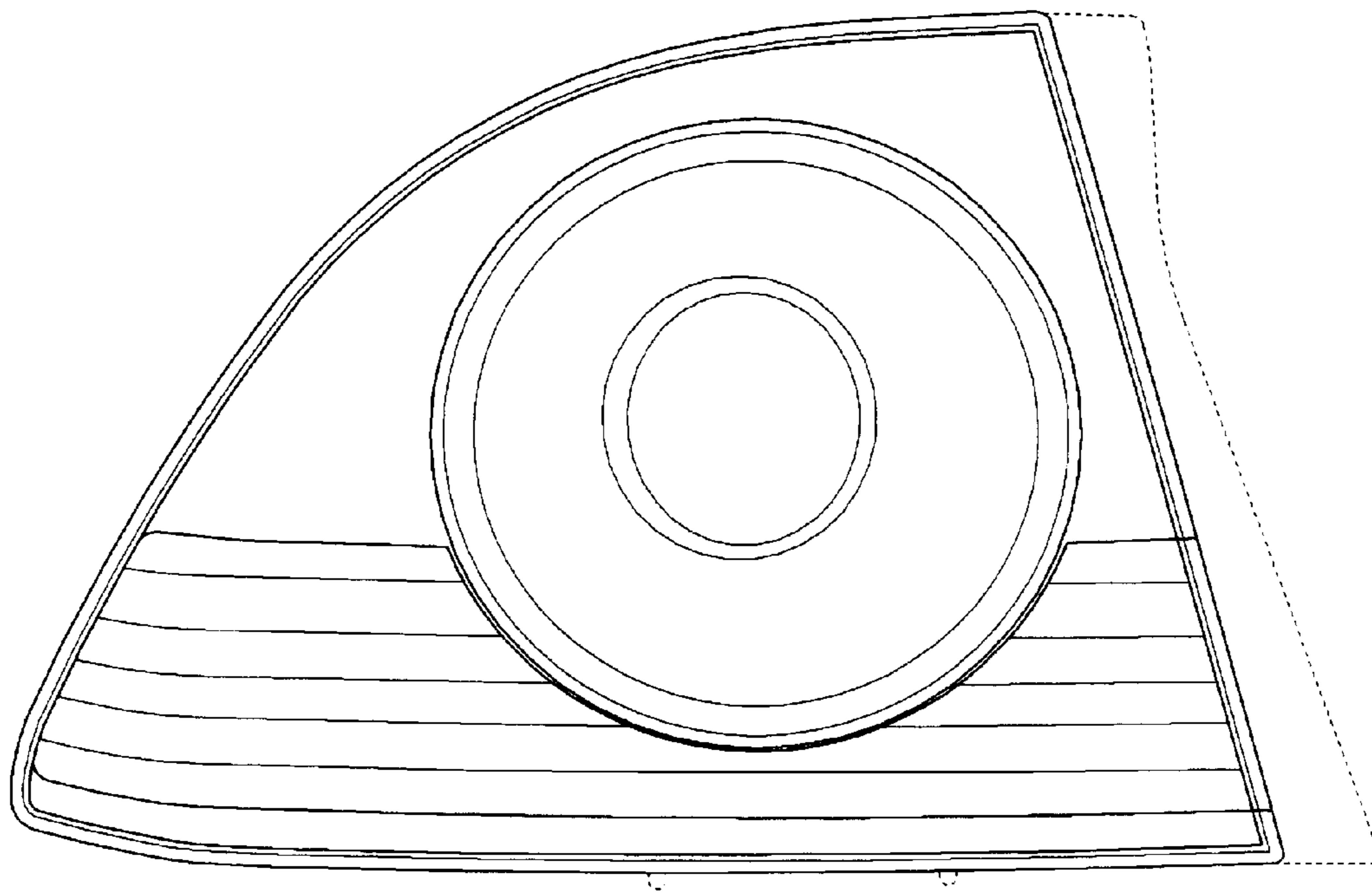

F I G. 2

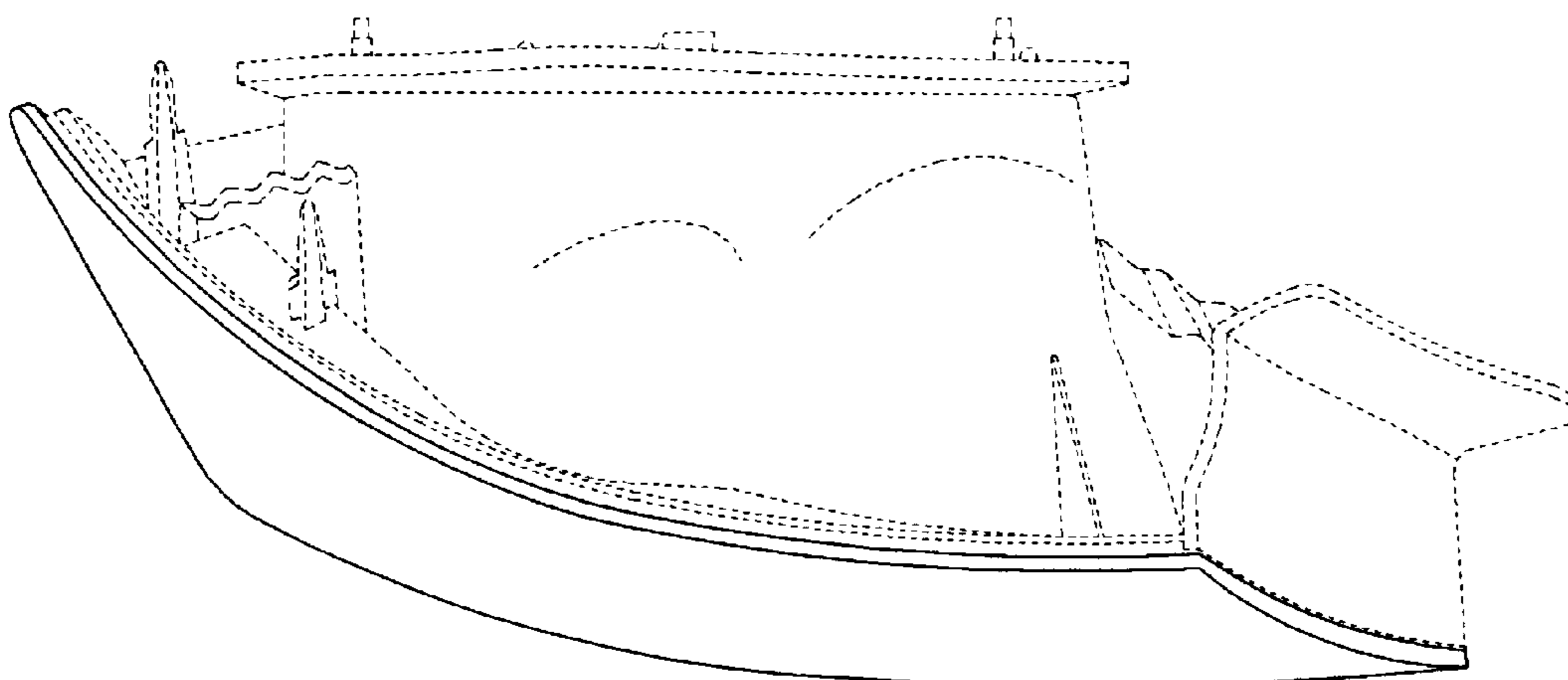

F I G. 3

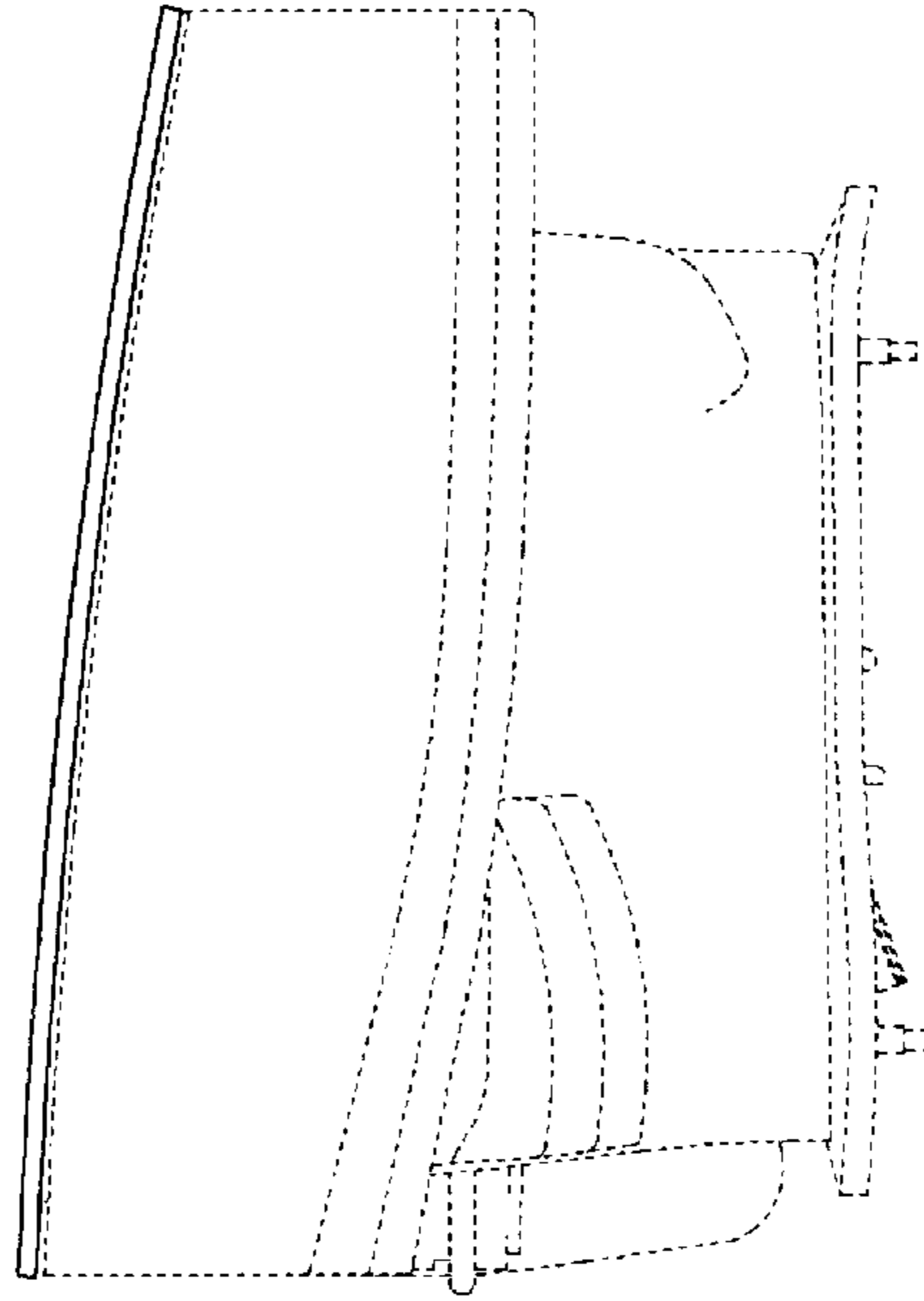

F I G. 4

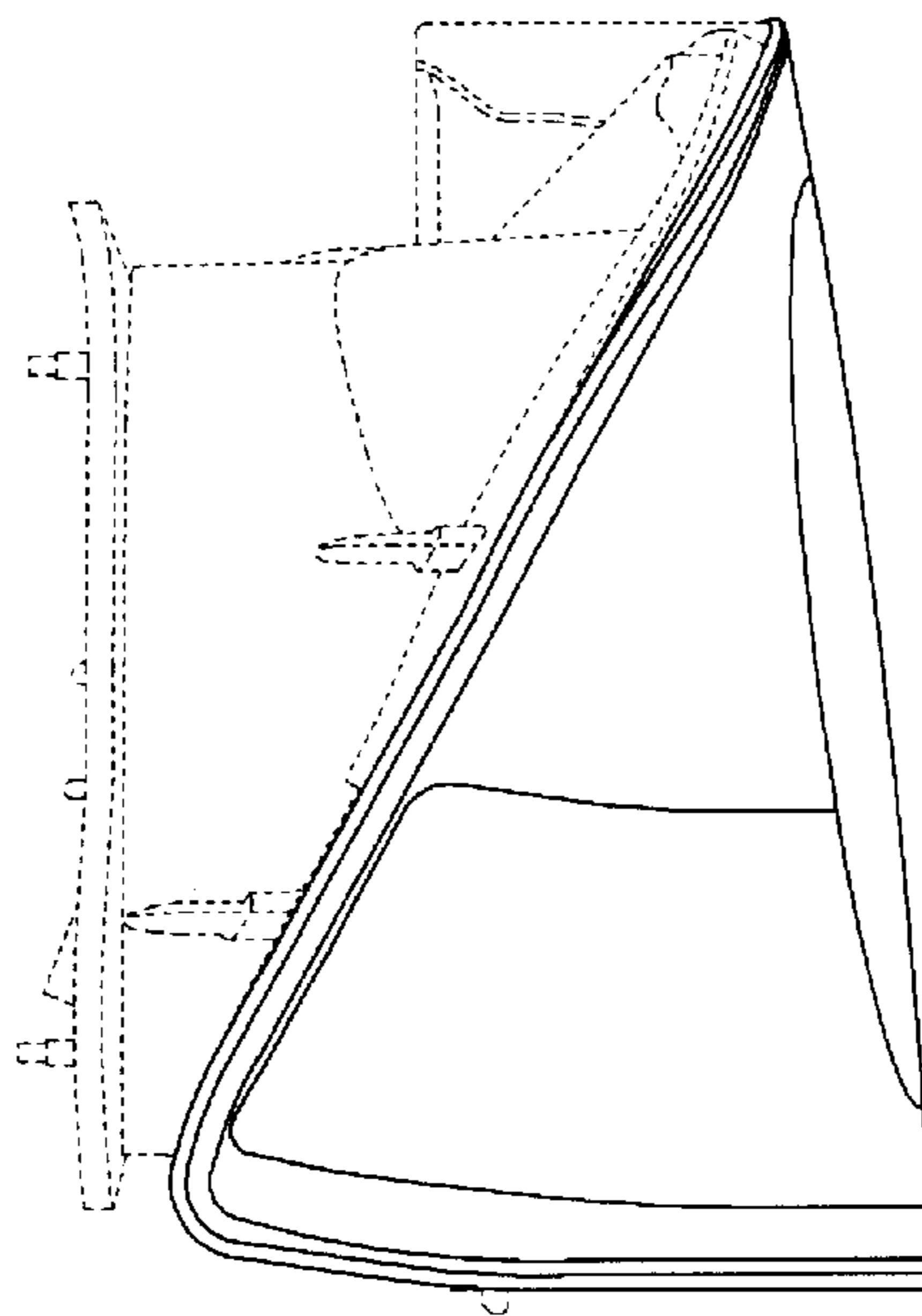

F I G. 5

