



US00D529181S

(12) **United States Design Patent** (10) **Patent No.:** **US D529,181 S**
Loyd (45) **Date of Patent:** **** Sep. 26, 2006**

(54) **SPA**

(76) Inventor: **Casey Loyd**, 1462 E. 9th St., Pomona, CA (US) 91766

(**) Term: **14 Years**

(21) Appl. No.: **29/222,575**

(22) Filed: **Jan. 31, 2005**

(51) **LOC (8) Cl.** **24-04**

(52) **U.S. Cl.** **D24/204**

(58) **Field of Classification Search** D24/201, D24/204, 205; D23/277; 601/154-158; 4/541.1-541.6, 4/547, 578.1, 579

See application file for complete search history.

(56) **References Cited**

U.S. PATENT DOCUMENTS

D266,697 S	*	10/1982	Topete	D24/204
D266,698 S	*	10/1982	Topete	D24/204
D266,699 S	*	10/1982	Topete	D24/204
D266,789 S	*	11/1982	Topete	D24/204
D266,946 S	*	11/1982	Topete	D24/204
D266,947 S	*	11/1982	Topete	D24/204
D277,135 S	*	1/1985	Sullivan	D24/204
D385,359 S	*	10/1997	Kelley	D24/204

OTHER PUBLICATIONS

Catalogue page from Dimension One Spas catalogue, dated 2001.

* cited by examiner

Primary Examiner—Ian Simmons

Assistant Examiner—Melanie Levy

(74) *Attorney, Agent, or Firm*—Denton L. Anderson; Sheldon & Mak PC

(57) **CLAIM**

The ornamental design for a spa, as shown and described.

DESCRIPTION

FIG. 1 is a left front perspective view of the spa of the invention;

FIG. 2 is a front perspective view of the spa illustrated in FIG. 1;

FIG. 3 is a right end perspective view of the spa illustrated in FIG. 1;

FIG. 4 is a left end perspective view of the spa illustrated in FIG. 1;

FIG. 5 is a front and rear elevation view of the spa illustrated in FIG. 1;

FIG. 6 is a left end elevation view of the spa illustrated in FIG. 1; and,

FIG. 7 is a right end elevation view of the spa illustrated in FIG. 1.

The broken lines are for illustrative purposes only and form no part of the claimed design.

1 Claim, 5 Drawing Sheets

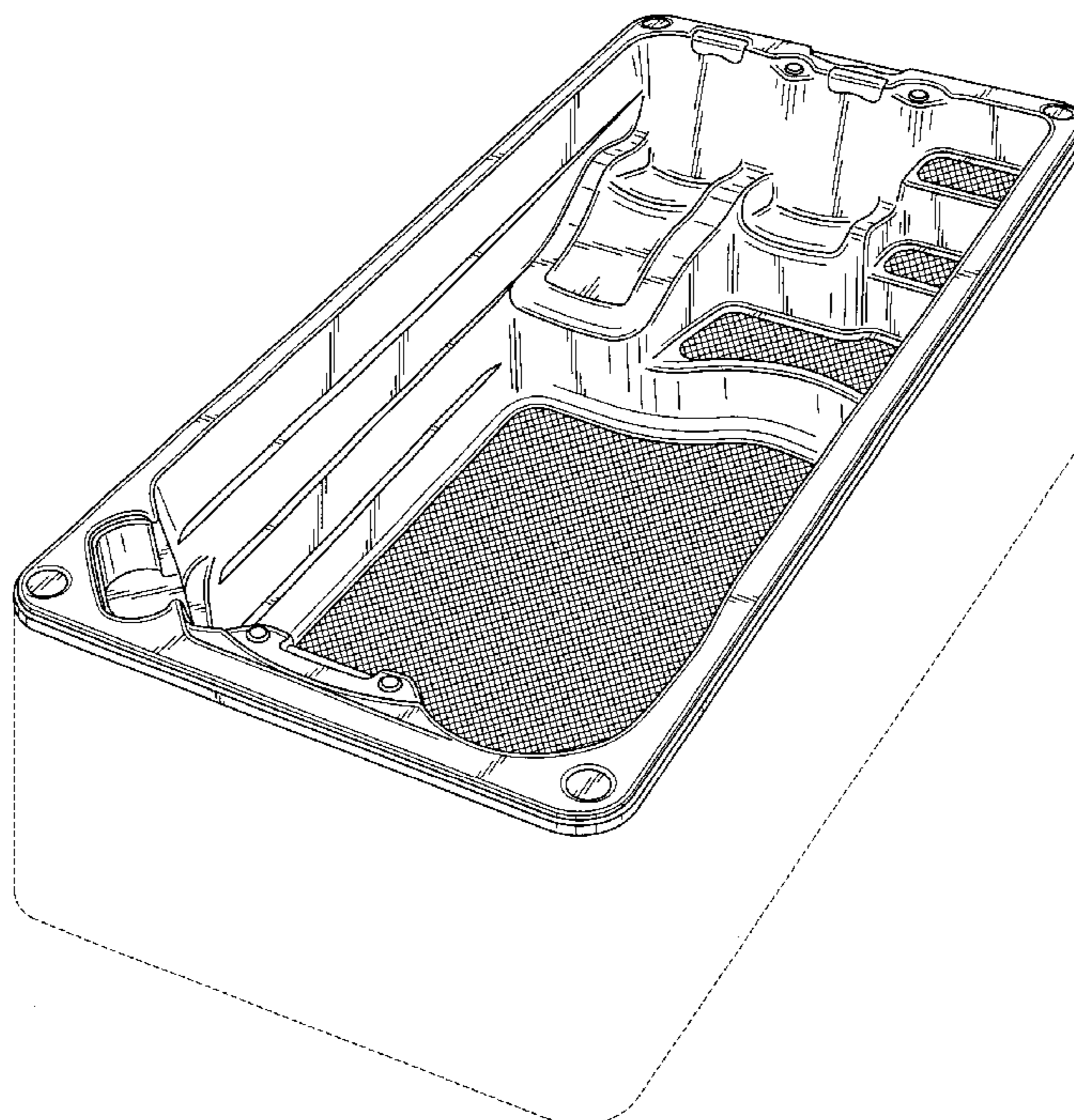

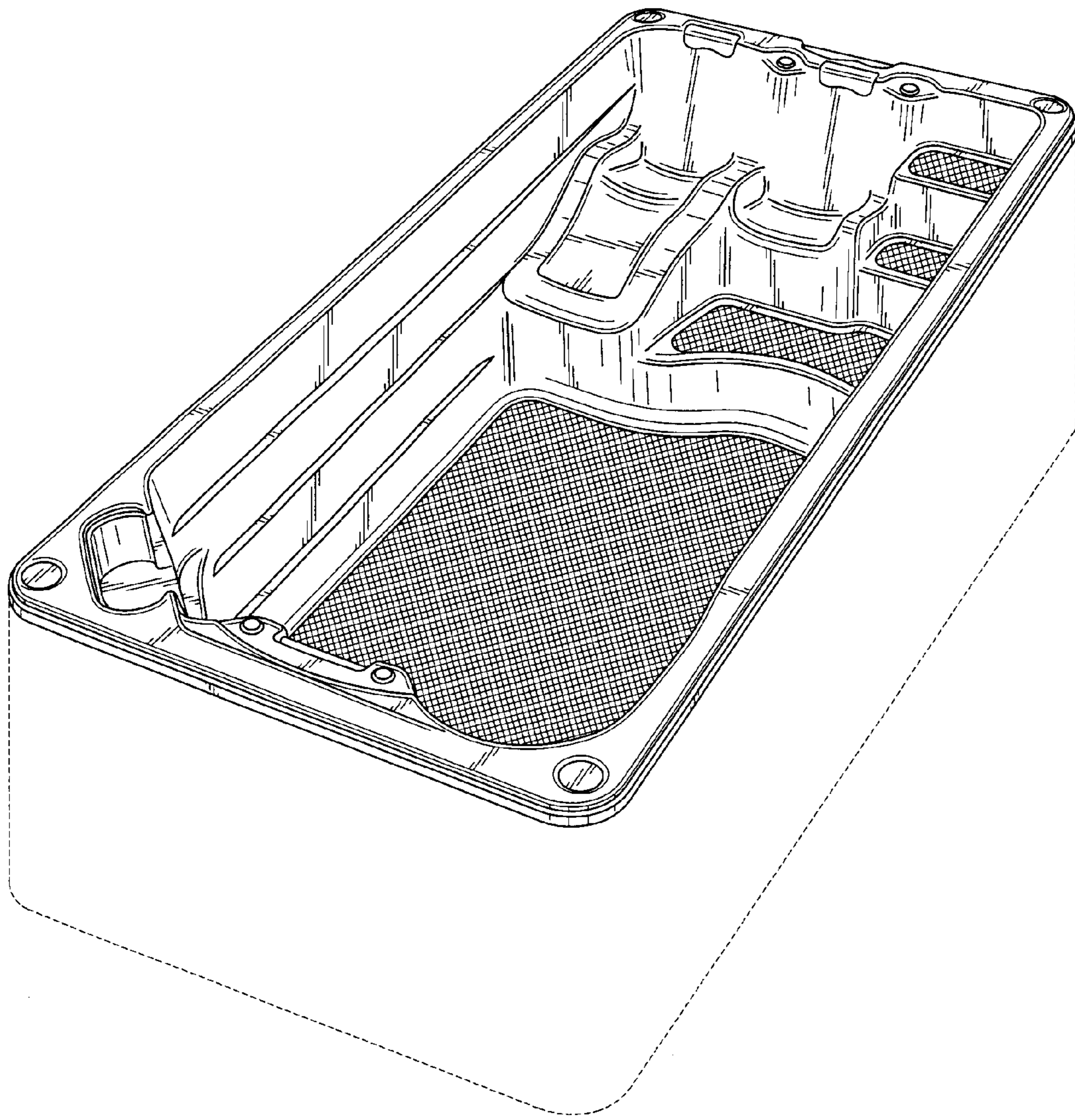

FIG. 1

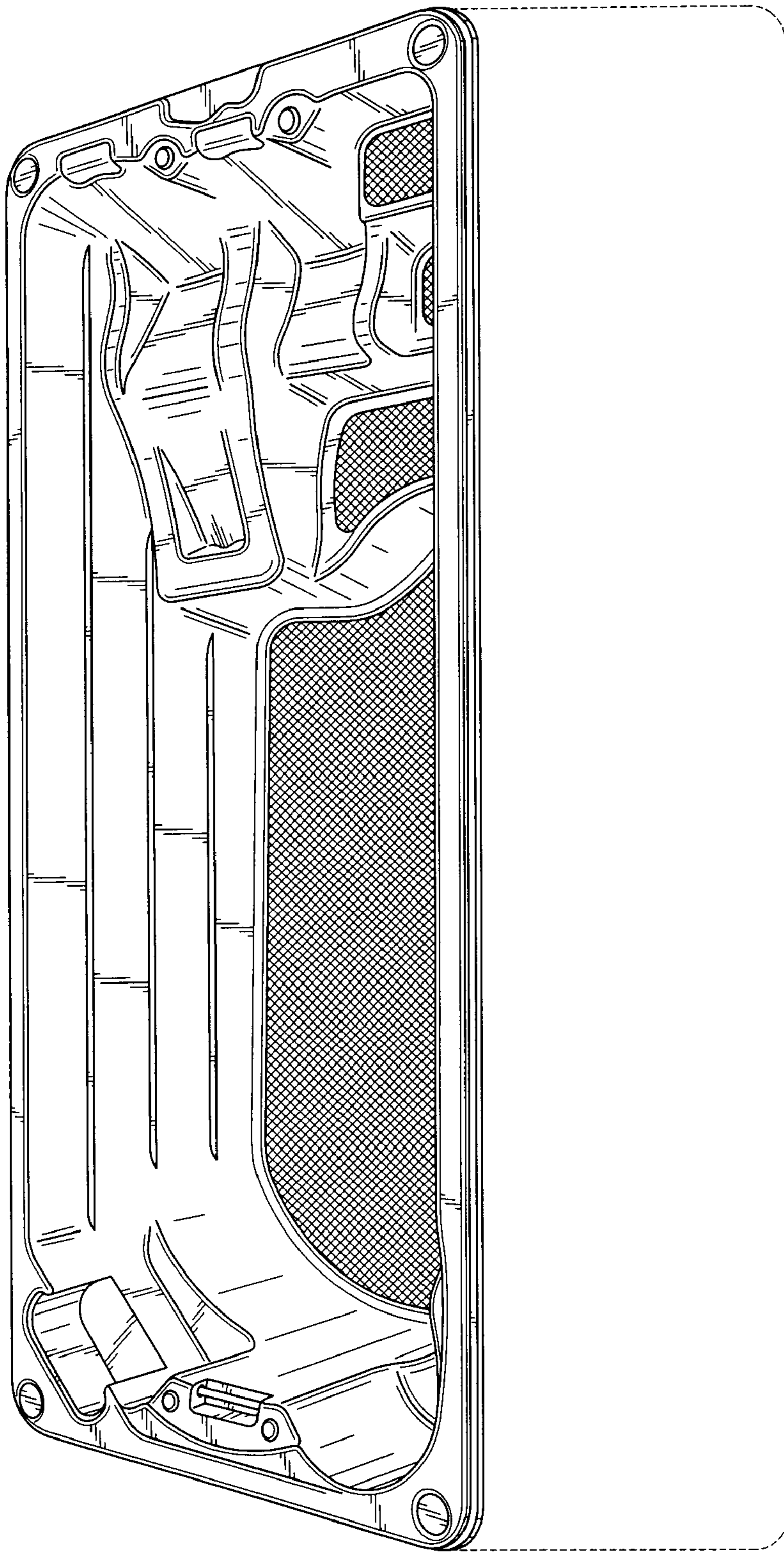

FIG. 2

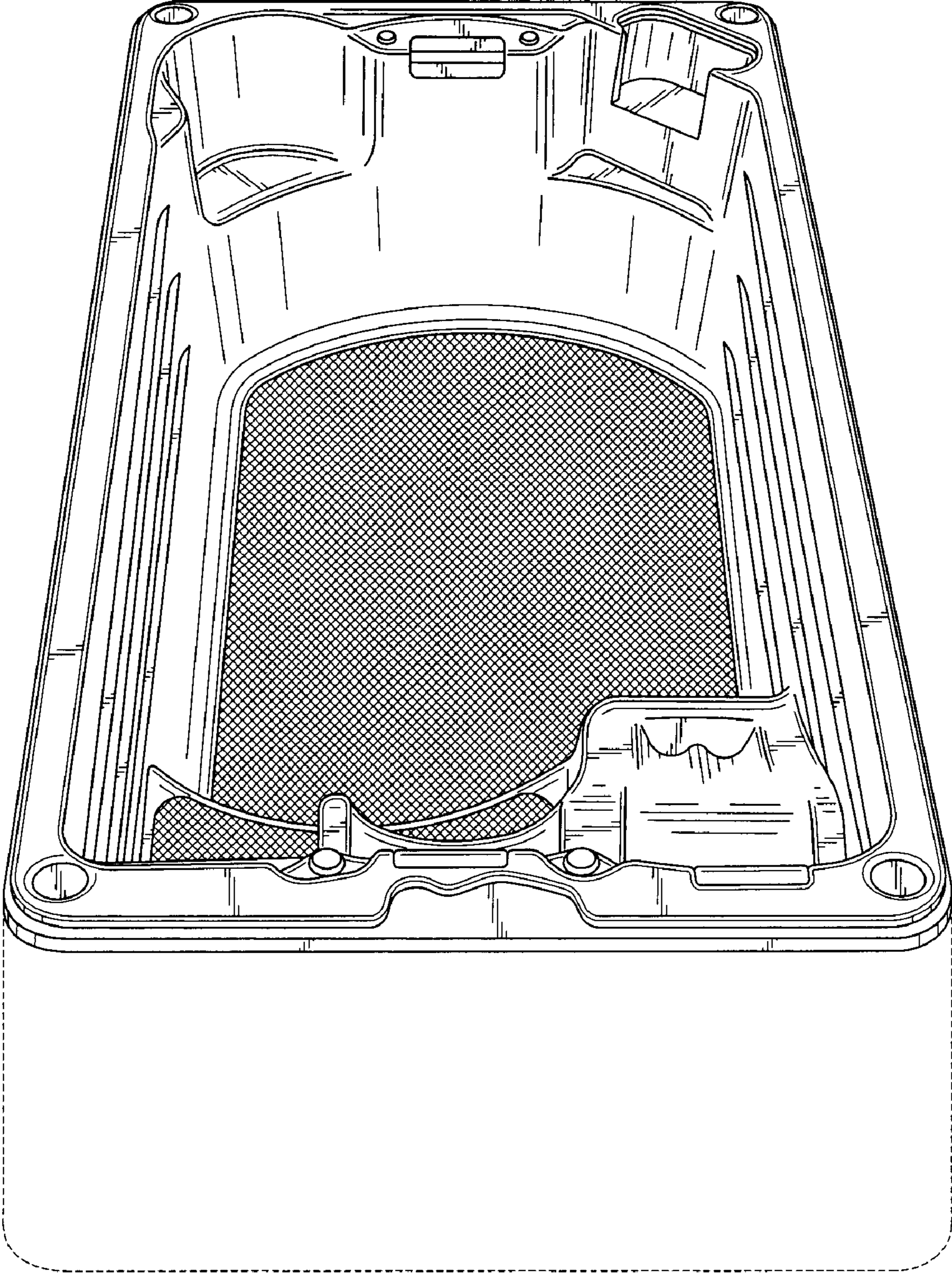

FIG. 3

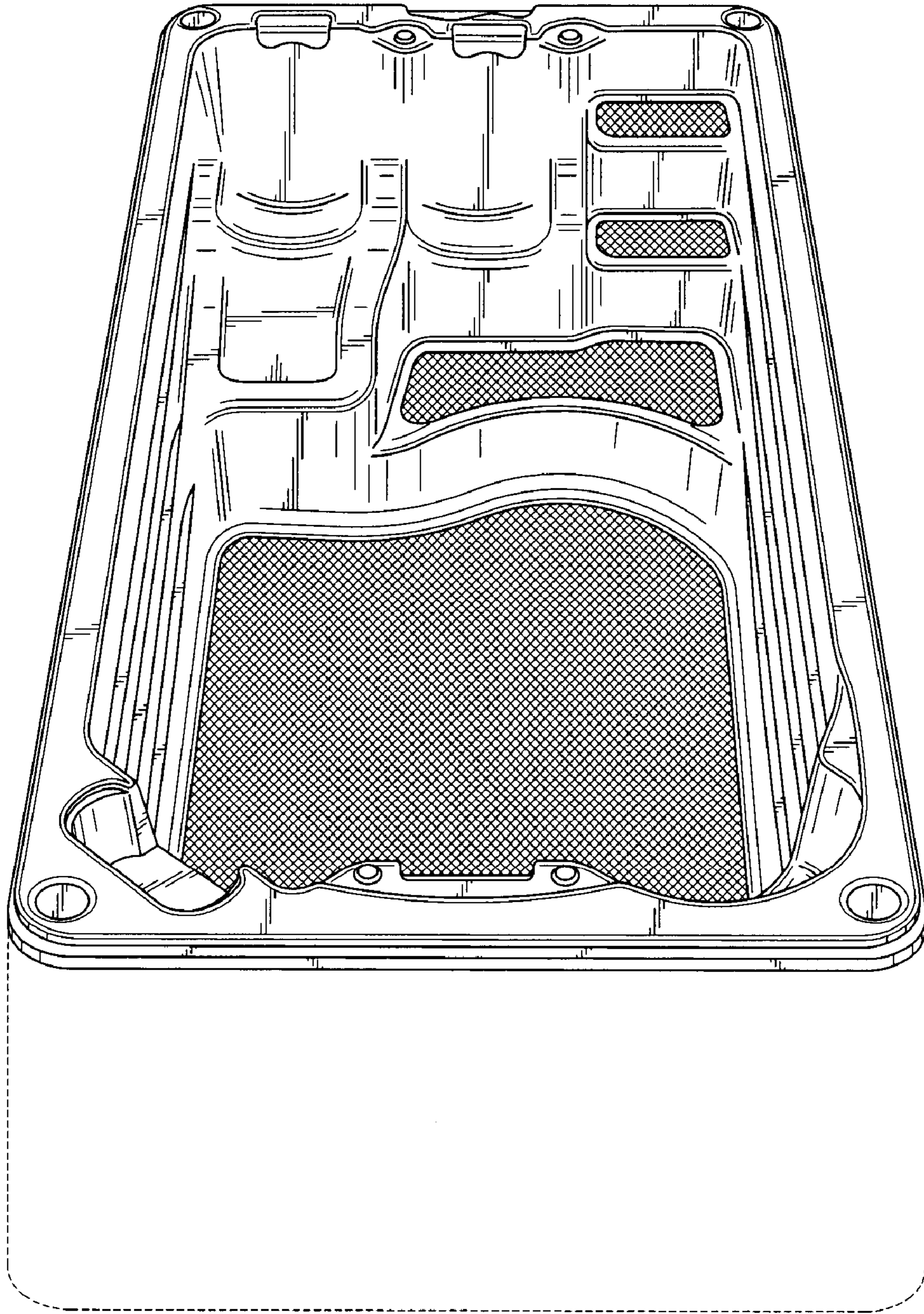

FIG. 4

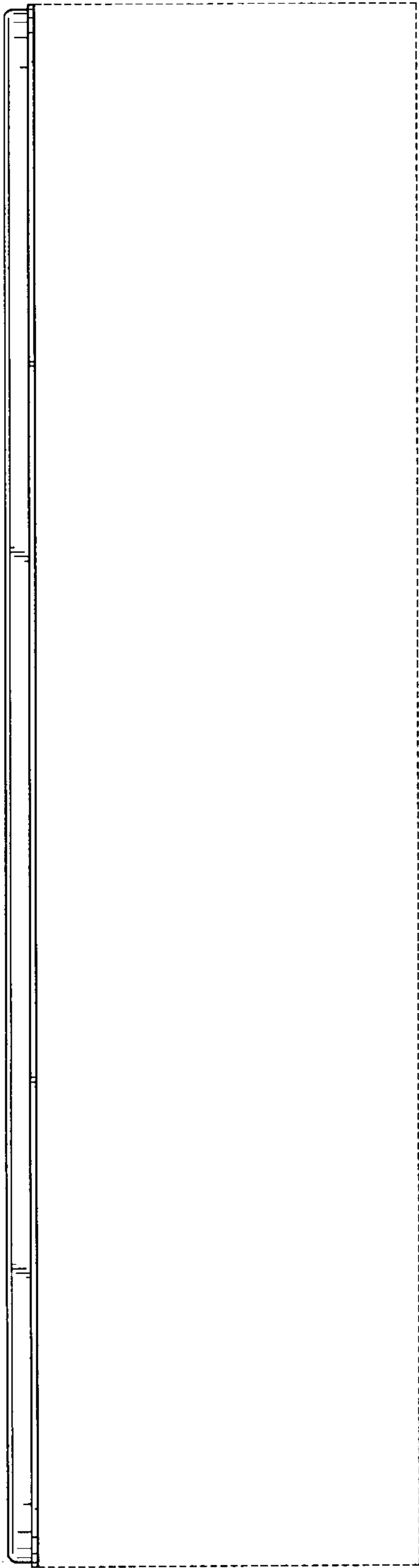

Fig. 5

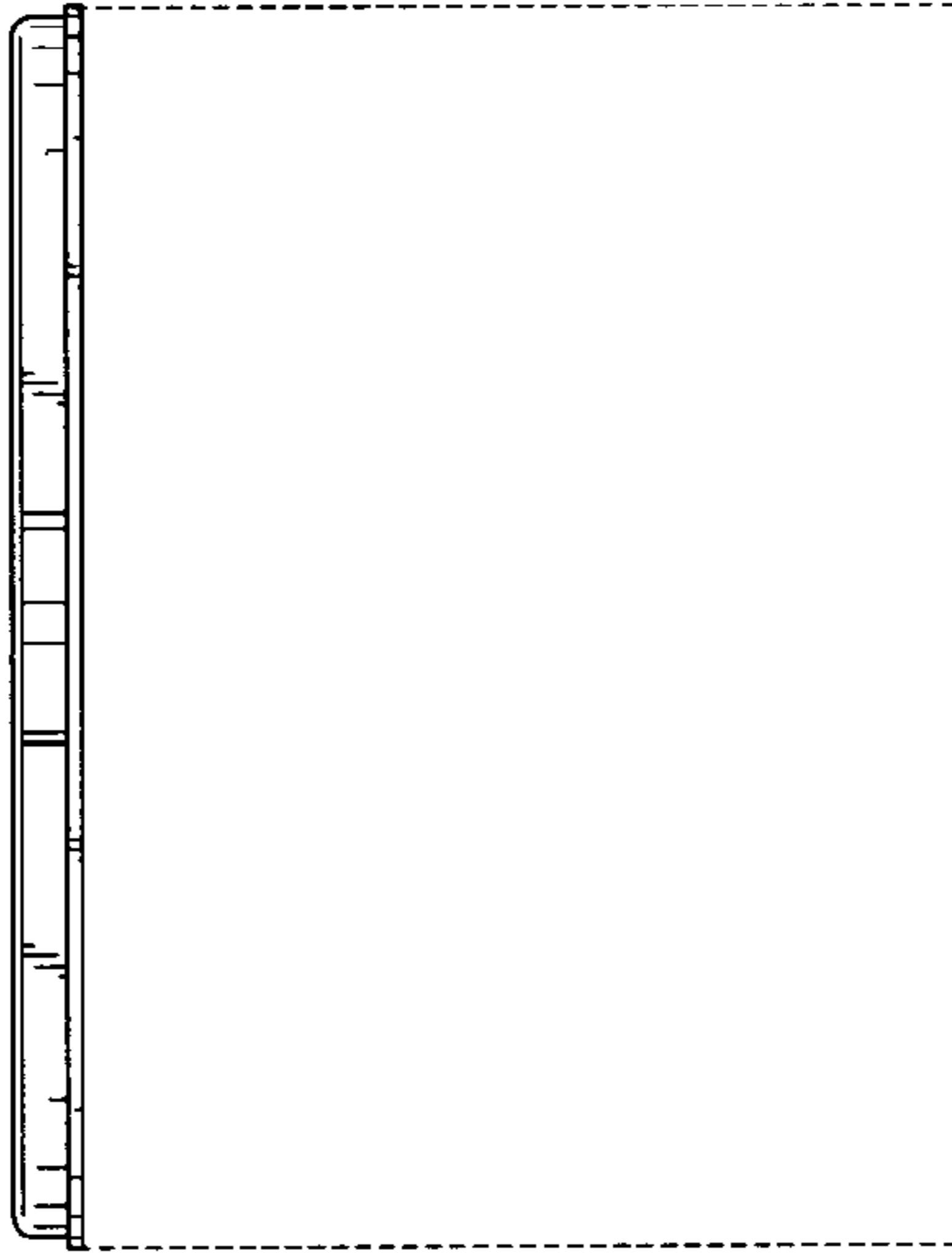

Fig. 7

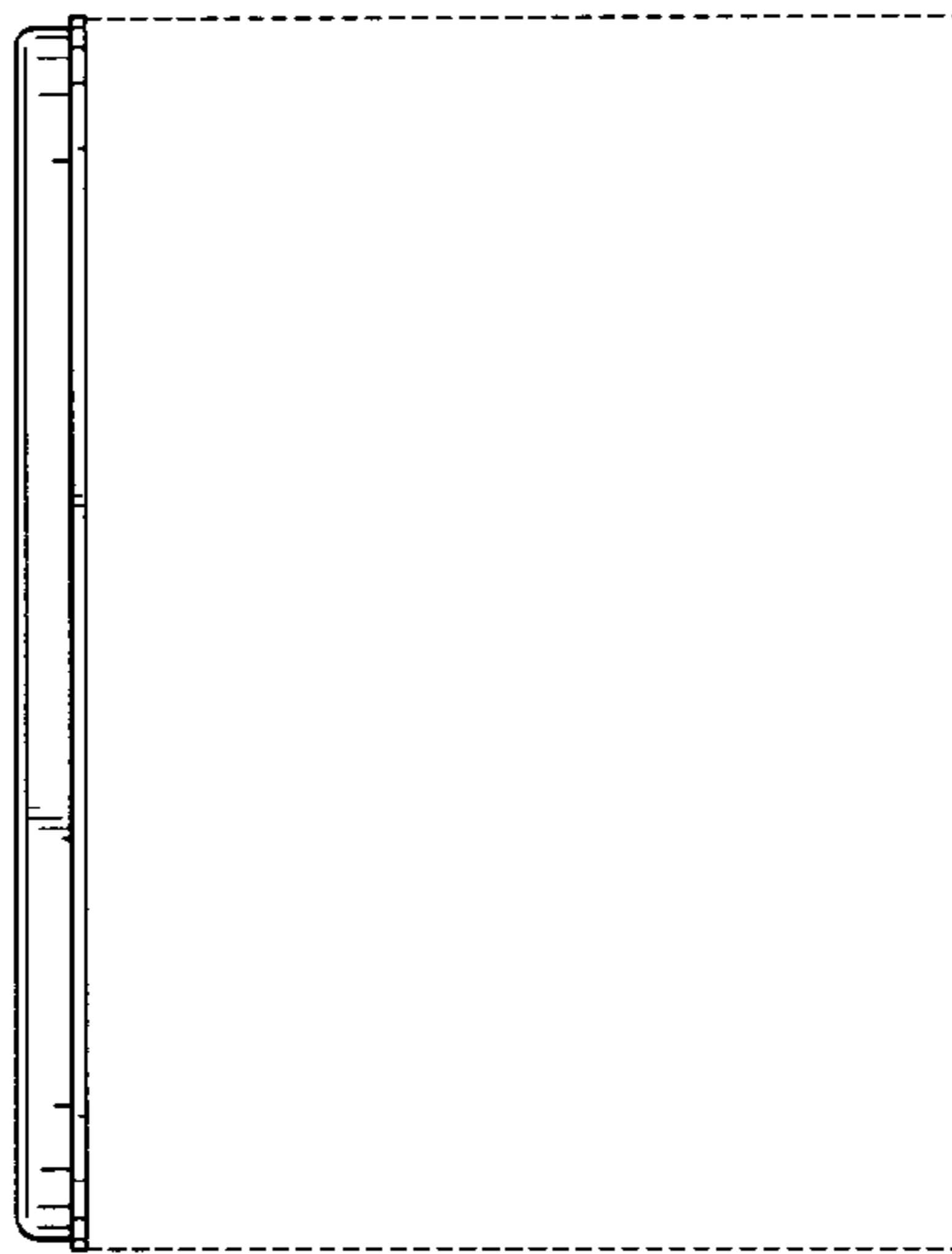

Fig. 6