



US00D528950S

(12) **United States Design Patent**
Jaskuloski

(10) **Patent No.:** **US D528,950 S**

(45) **Date of Patent:** **** Sep. 26, 2006**

(54) **TRAILER HITCH ALIGNER SET**

(76) **Inventor:** **Delbert E. Jaskuloski**, 538 S. Jeremy St., Salt Lake City, UT (US) 84104

(**) **Term:** **14 Years**

(21) **Appl. No.:** **29/215,450**

(22) **Filed:** **Oct. 20, 2004**

(51) **LOC (8) Cl.** **12-16**

(52) **U.S. Cl.** **D12/162**

(58) **Field of Classification Search** D12/106,
D12/161, 162; D3/7-9; 135/65-76; 280/402-404,
280/405.2, 407, 407.1, 416.2, 455.1, 491.5,
280/186, 511, 512, 513, 482; D10/66, 70
See application file for complete search history.

(56) **References Cited**

U.S. PATENT DOCUMENTS

3,228,445 A * 1/1966 Mayotte D12/162
D230,195 S * 1/1974 Fukushima D16/132

5,382,109 A * 1/1995 Nyman 403/316
6,113,125 A * 9/2000 Colibert et al. 280/511
2002/0070529 A1 * 6/2002 Dravec 280/477
2003/0075898 A1 * 4/2003 Perkins 280/477

* cited by examiner

Primary Examiner—Louis S. Zarfes

Assistant Examiner—Michael Pratt

(74) *Attorney, Agent, or Firm*—Jeffrey K. Sato

(57) **CLAIM**

The ornamental design for a trailer hitch aligner set, as shown and described.

DESCRIPTION

FIG. 1 is a front elevation view of a trailer hitch aligner set showing my new design.

FIG. 2 is a back elevation view thereof;

FIG. 3 is a side elevation view thereof;

FIG. 4 is a bottom plan view thereof; and,

FIG. 5 is a top plan view thereof.

1 Claim, 4 Drawing Sheets

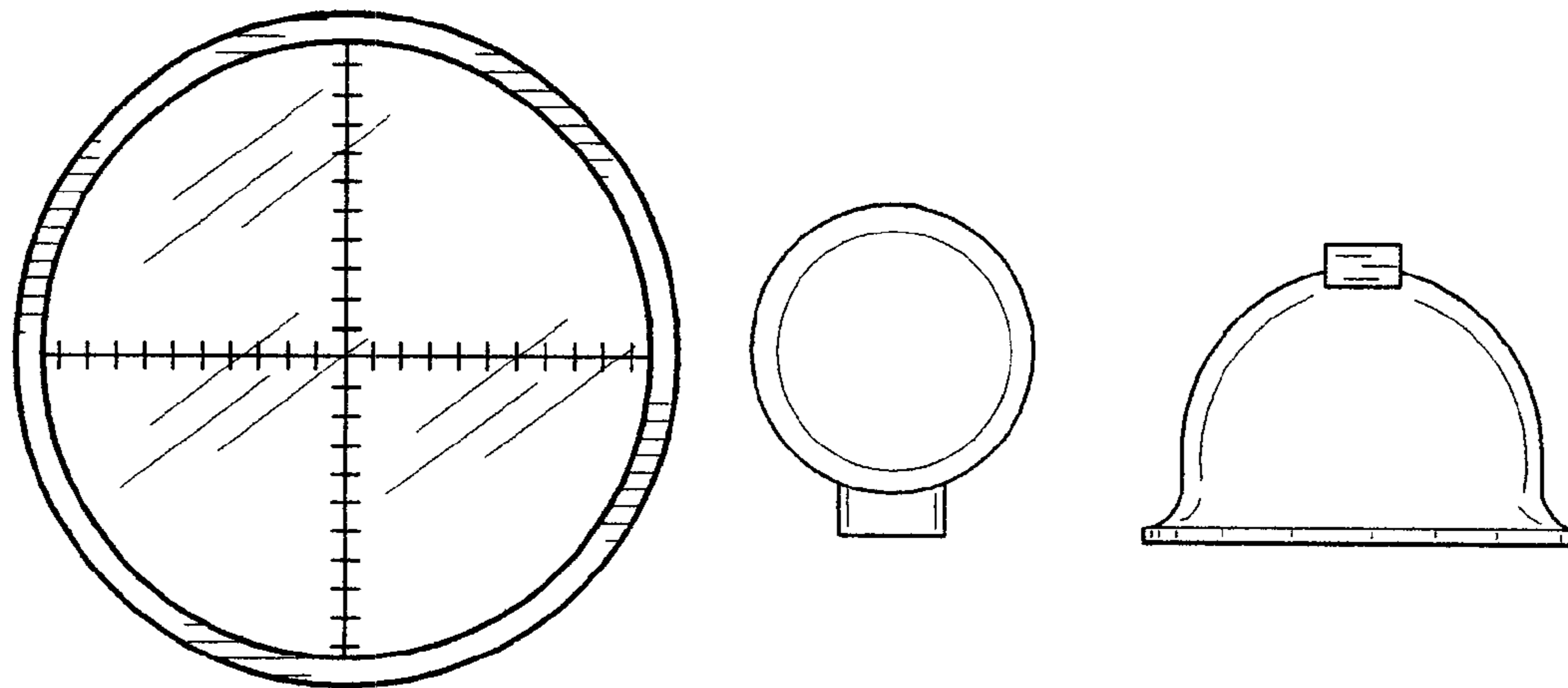

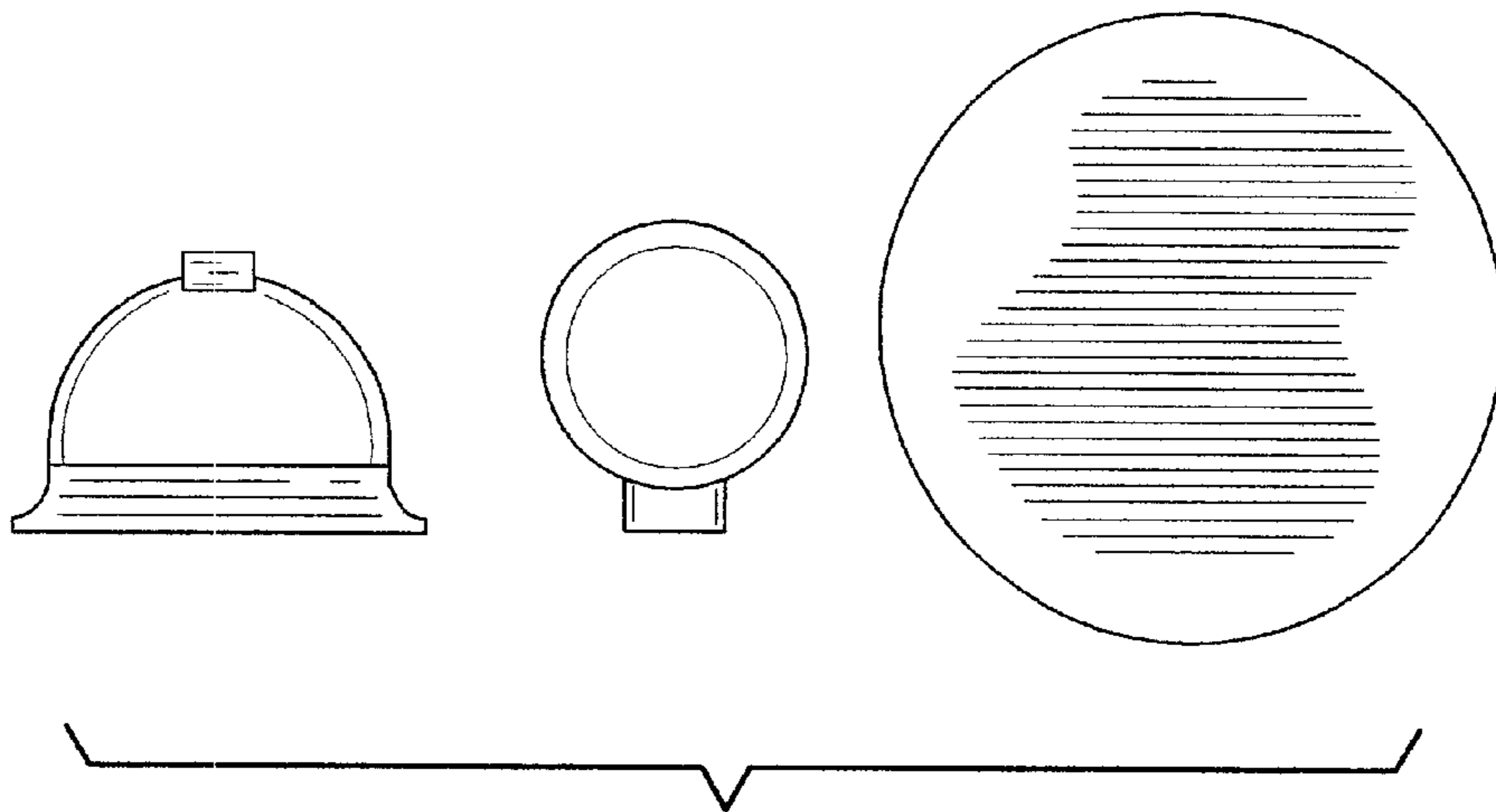
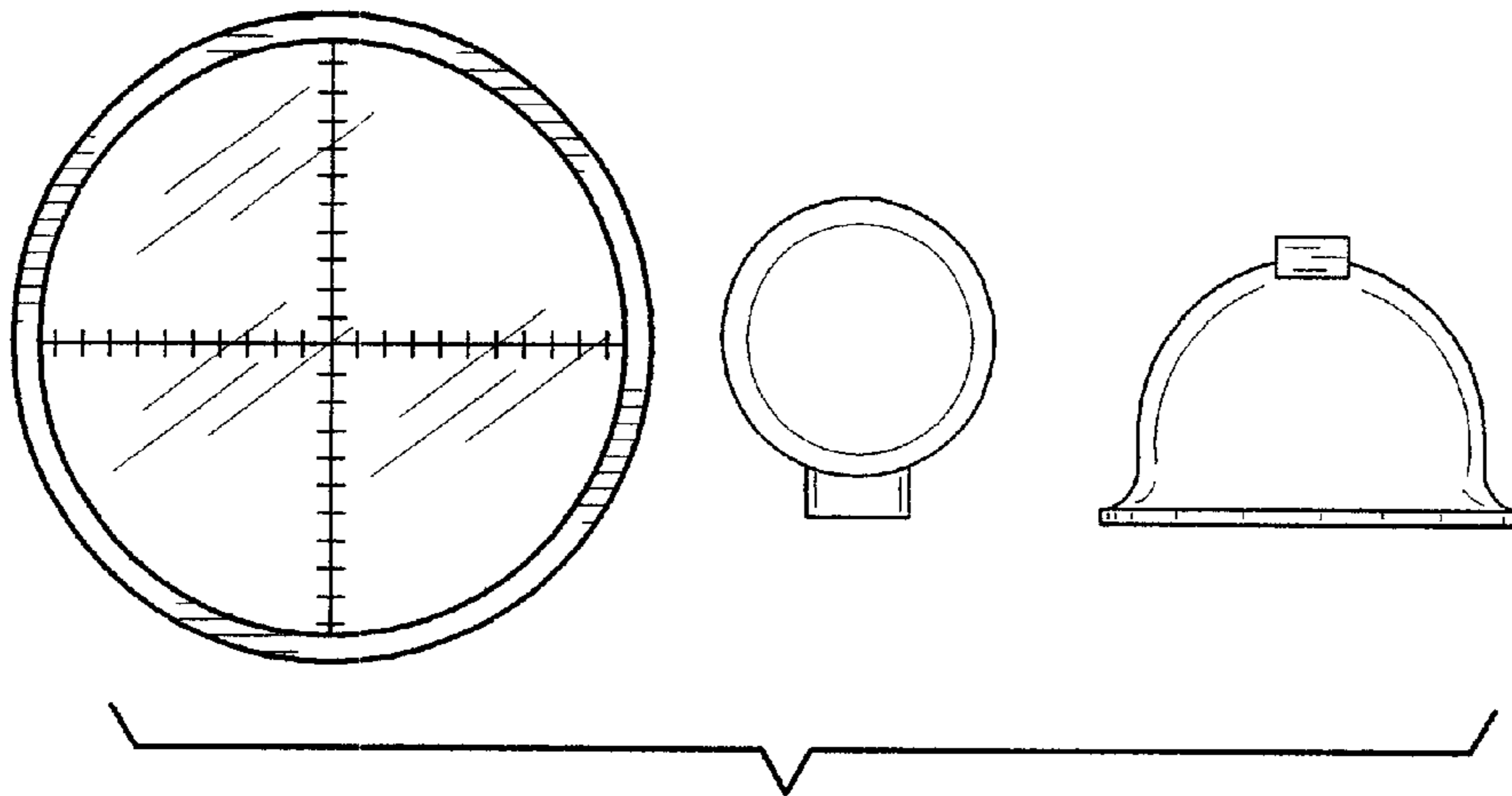

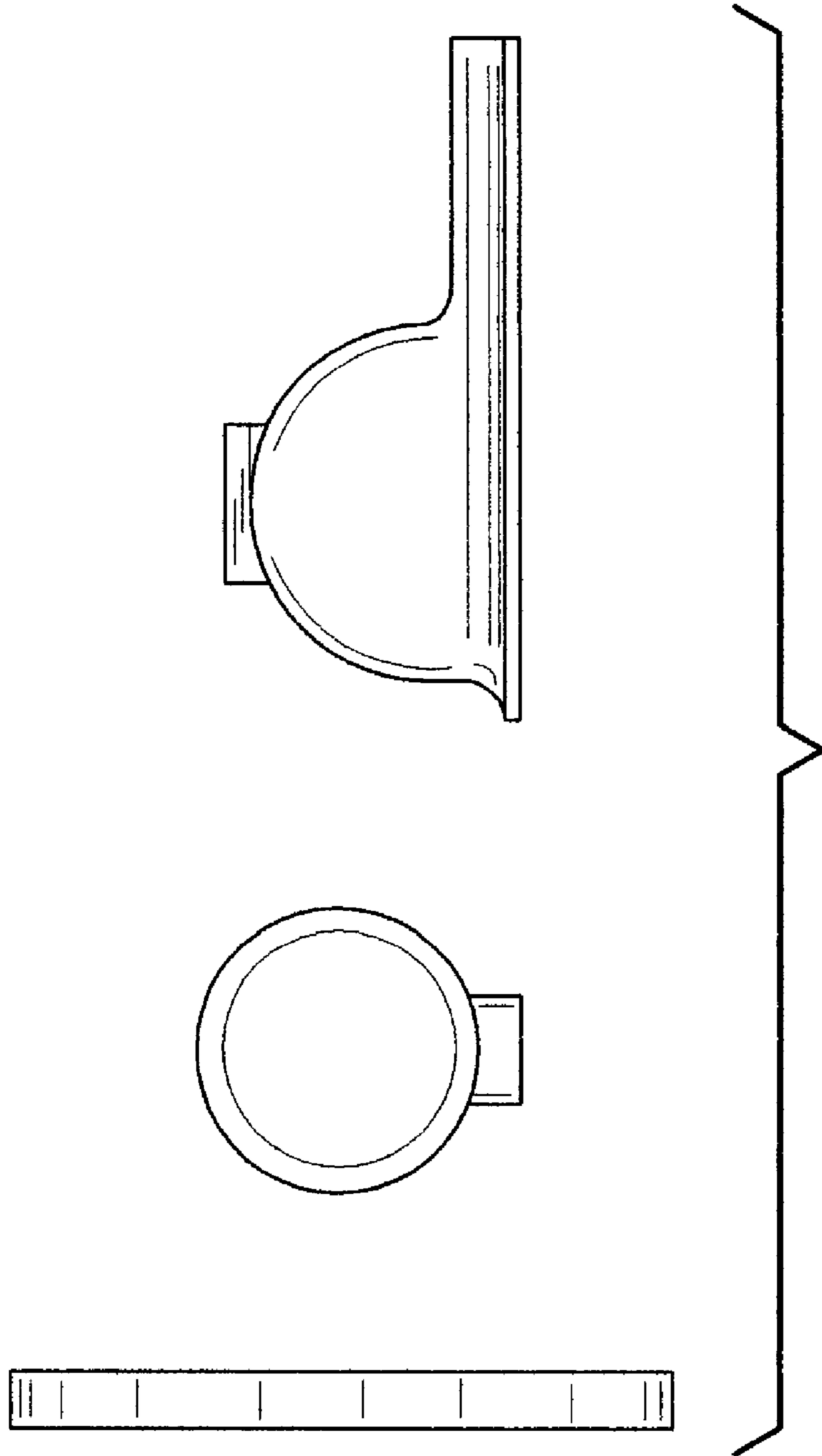

FIG. 3

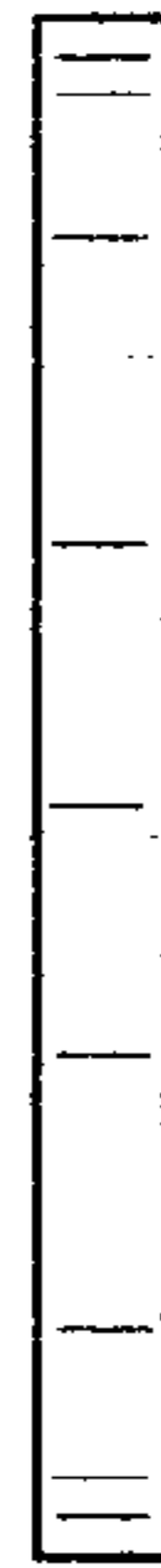
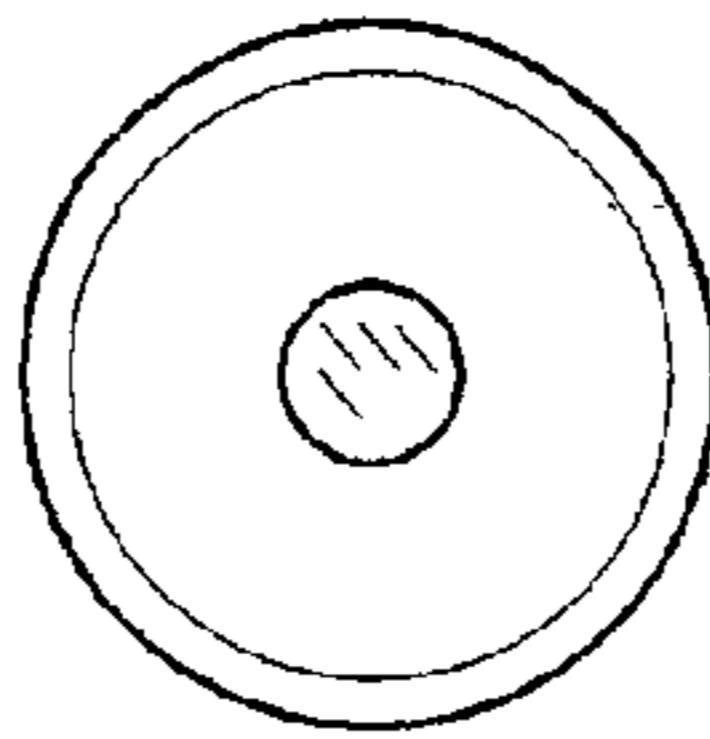
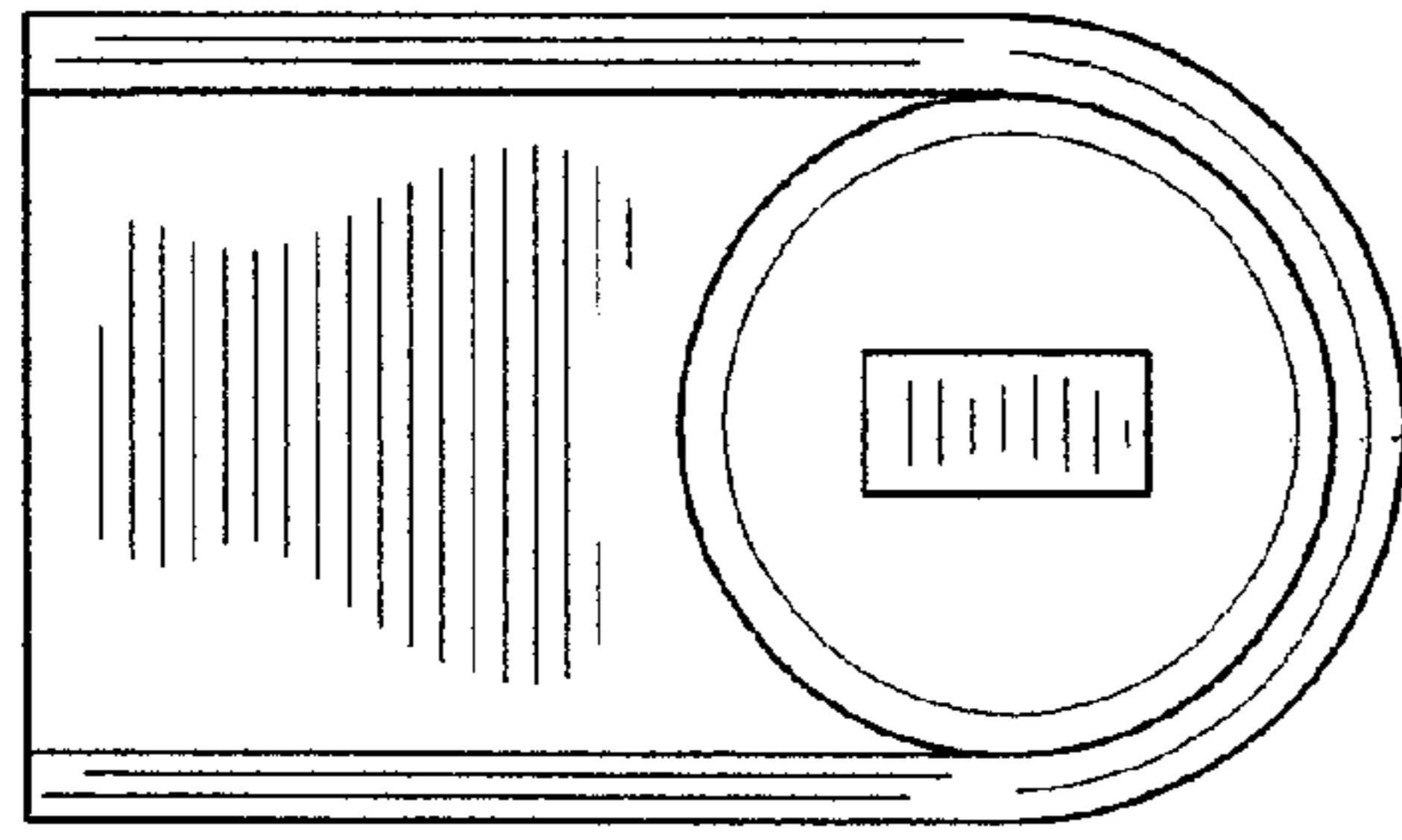

FIG. 4

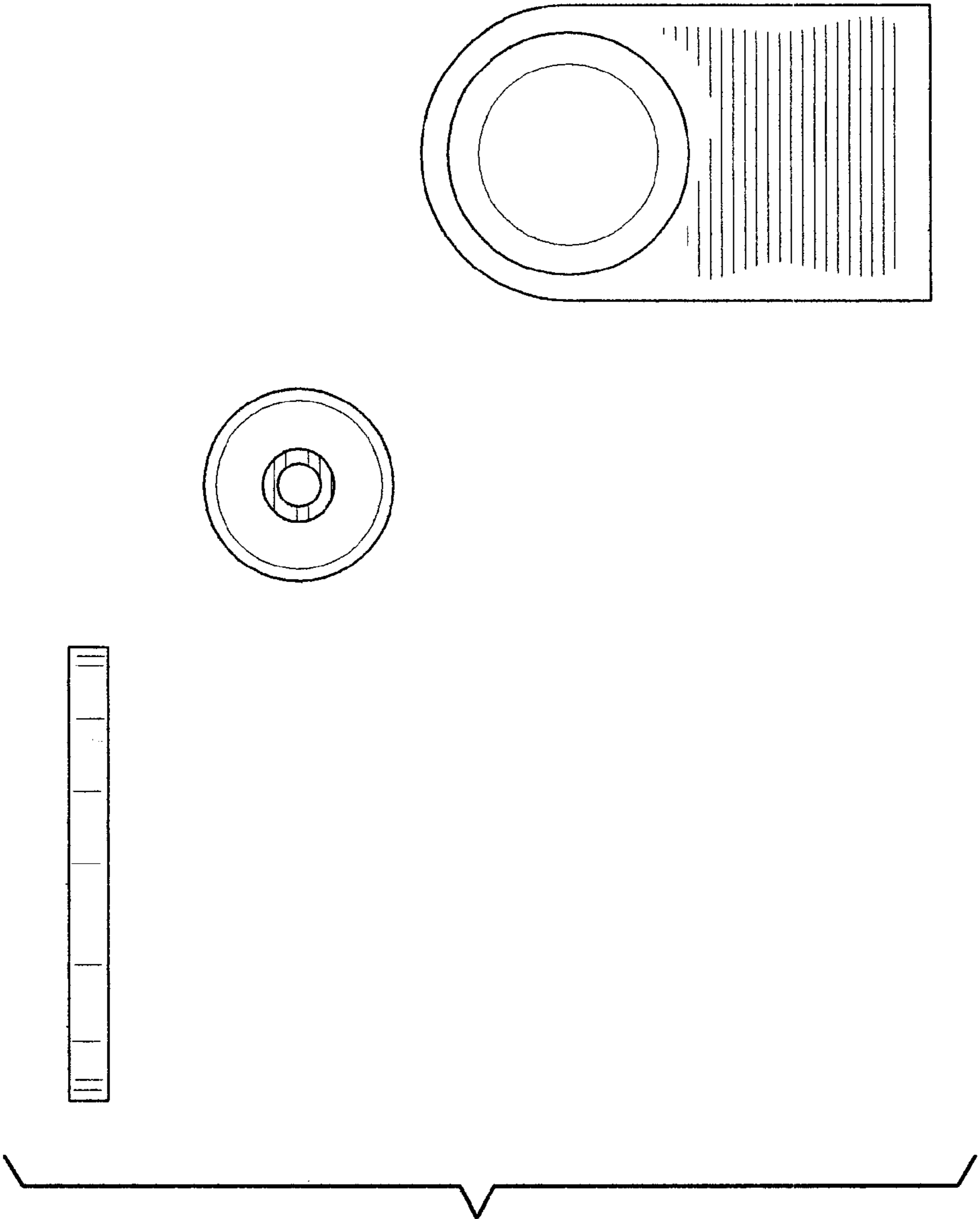

FIG. 5