



US00D528698S

(12) **United States Design Patent**
Rizzuto, Jr.

(10) **Patent No.:** **US D528,698 S**

(45) **Date of Patent:** **** Sep. 19, 2006**

(54) **HAIR DRYER**

(75) Inventor: **Leandro Rizzuto, Jr.**, Sheridan, WY
(US)

(73) Assignee: **Conair Corporation**, Stamford, CT
(US)

(**) Term: **14 Years**

(21) Appl. No.: **29/198,984**

(22) Filed: **Feb. 6, 2004**

(51) **LOC (8) Cl.** **28-03**

(52) **U.S. Cl.** **D28/13**

(58) **Field of Classification Search** D28/12-19;
34/96-101, 201; 392/380, 383, 384, 385,
392/381, 382; 219/222

See application file for complete search history.

(56) **References Cited**

U.S. PATENT DOCUMENTS

D239,471 S	*	4/1976	Gonzales	D28/18
D268,369 S	*	3/1983	McBrien	D28/13
D268,370 S	*	3/1983	McBrien	D28/13
D276,941 S	*	12/1984	Stansbury, Jr.	D28/13
D277,789 S	*	2/1985	Pajak	D28/13
4,711,988 A	*	12/1987	Thaler et al.	392/379
D341,224 S	*	11/1993	Drake et al.	D28/18
D343,698 S	*	1/1994	Sharples	D28/13
5,467,540 A	*	11/1995	Bastien	34/97
5,642,570 A	*	7/1997	Lee	34/98
D422,114 S	*	3/2000	Gudefin	D28/13

D428,528 S	*	7/2000	Deguines	D28/13
D432,716 S	*	10/2000	Goetschi	D28/13
6,285,828 B1	*	9/2001	Cafaro	392/385
6,398,710 B1	*	6/2002	Ishikawa et al.	600/3
D460,214 S	*	7/2002	Parodi	D28/13
D470,976 S	*	2/2003	Rizzuto, Jr.	D28/13
6,922,909 B1	*	8/2005	Andrew et al.	34/96

OTHER PUBLICATIONS

Modern Salon, Mar. 1987, p. 168 Super Turbo 2000.*

* cited by examiner

Primary Examiner—Lucy Lieberman

Assistant Examiner—Zenita I. Bennett

(74) *Attorney, Agent, or Firm*—Lawrence Cruz; Steven A. Garner

(57) **CLAIM**

The ornamental design for a hair dryer, as shown and described.

DESCRIPTION

FIG. 1 is a front view of a hair dryer according to the present invention;

FIG. 2 is a rear view of the hair dryer of FIG. 1;

FIG. 3 is a top plan view of the hair dryer of FIG. 1;

FIG. 4 is a right side elevation of the hair dryer of FIG. 1;

FIG. 5 is a bottom plan view of the hair dryer of FIG. 1; and,

FIG. 6 is a perspective view of the hair dryer of FIG. 1.

The broken lines in the drawing are for illustrative purposes only and form no part of the claimed design.

1 Claim, 3 Drawing Sheets

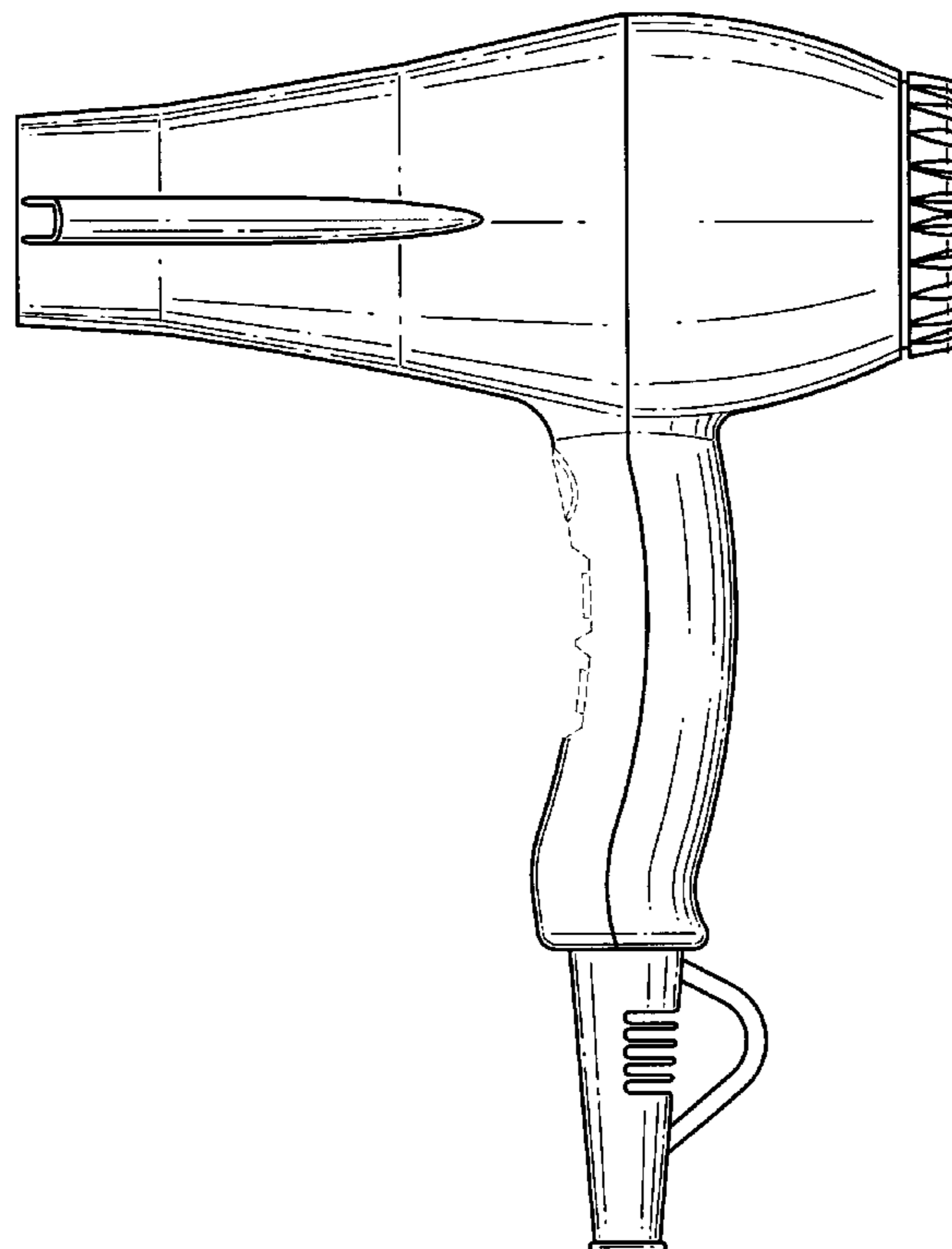

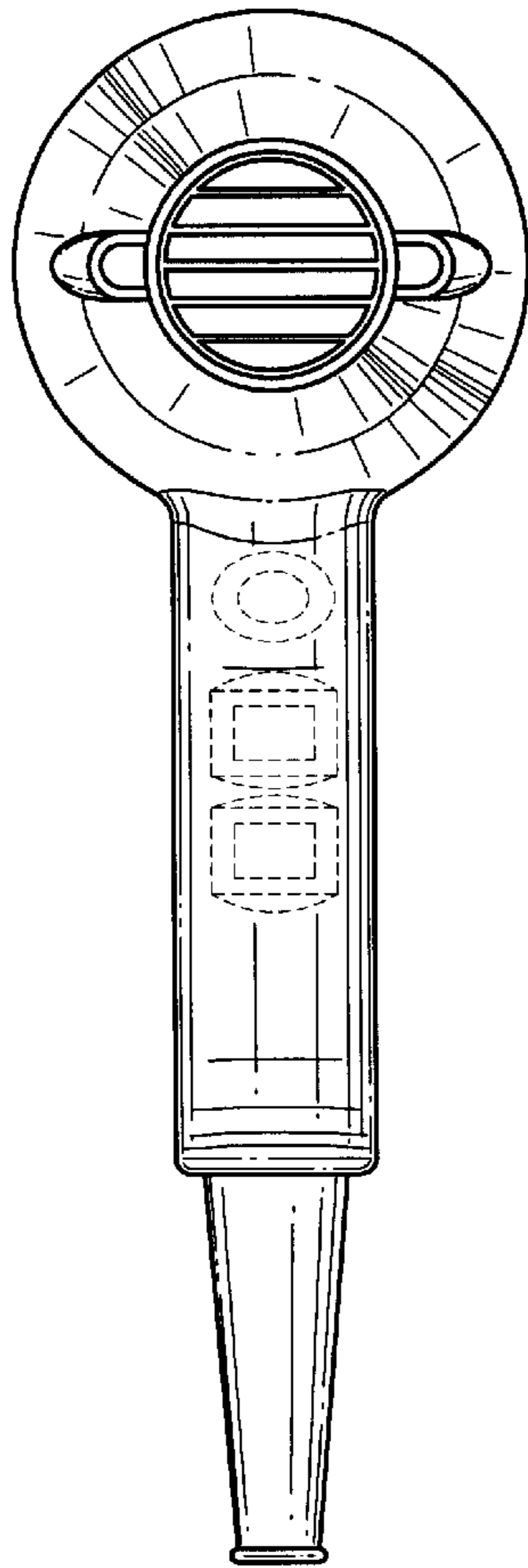

FIG. 1

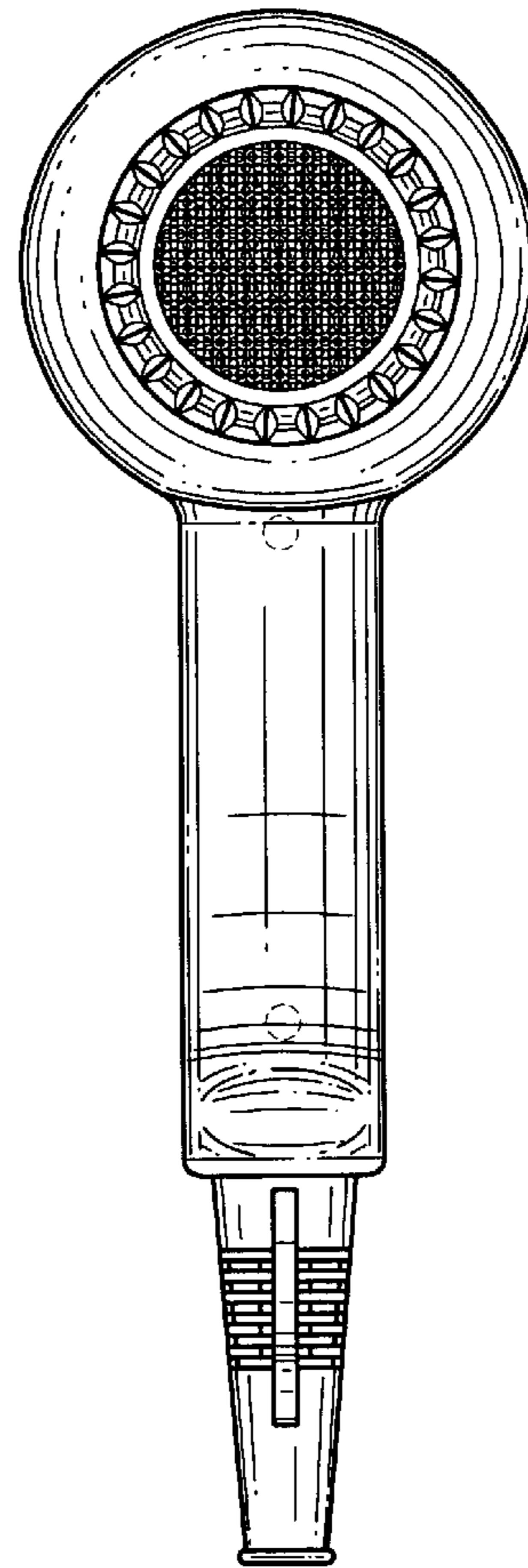

FIG. 2

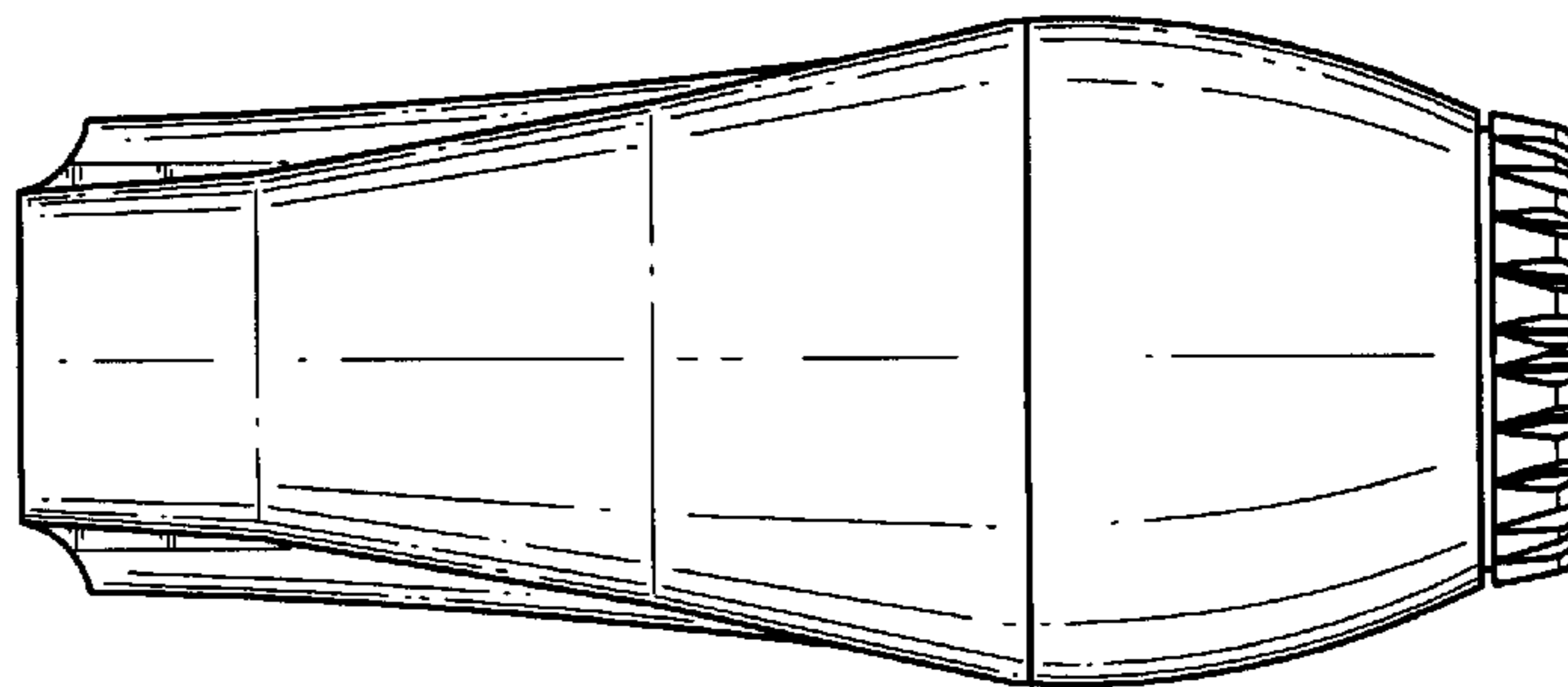
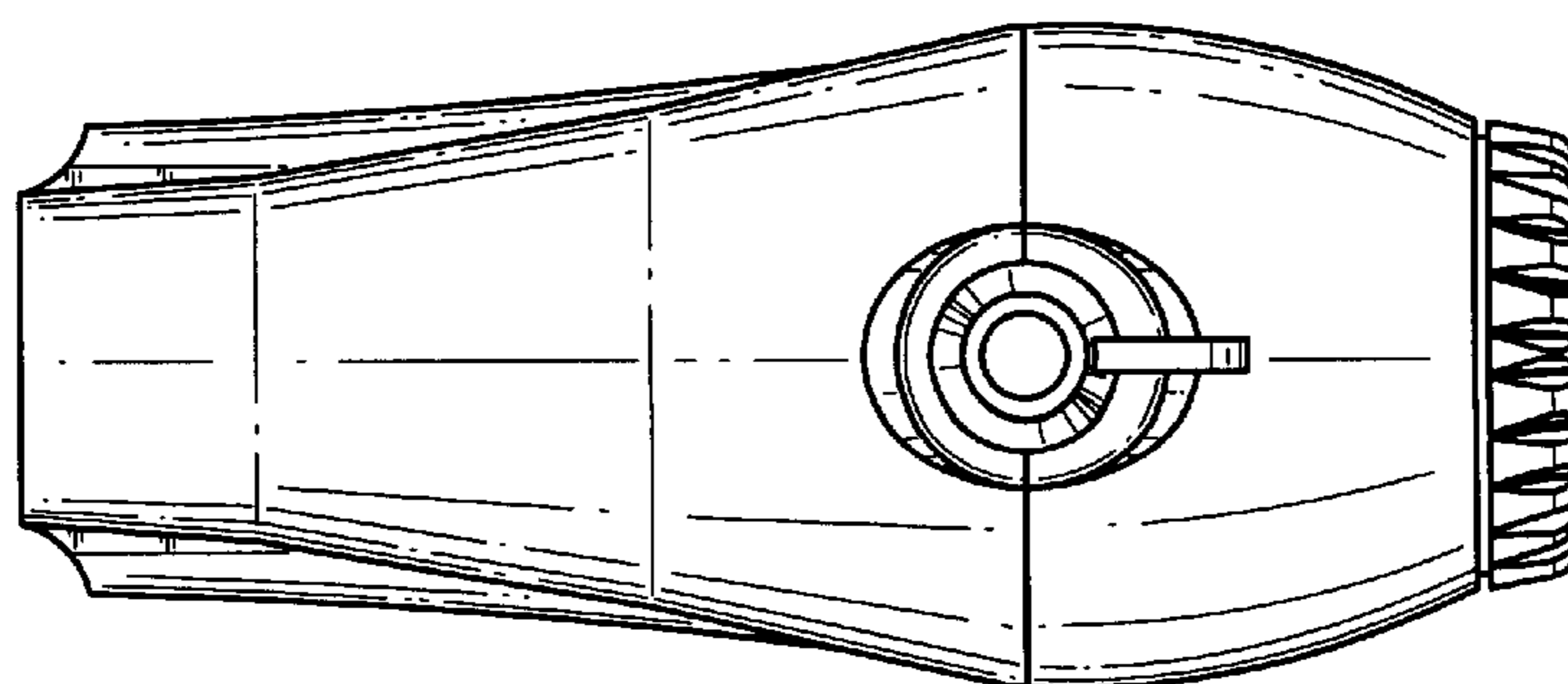
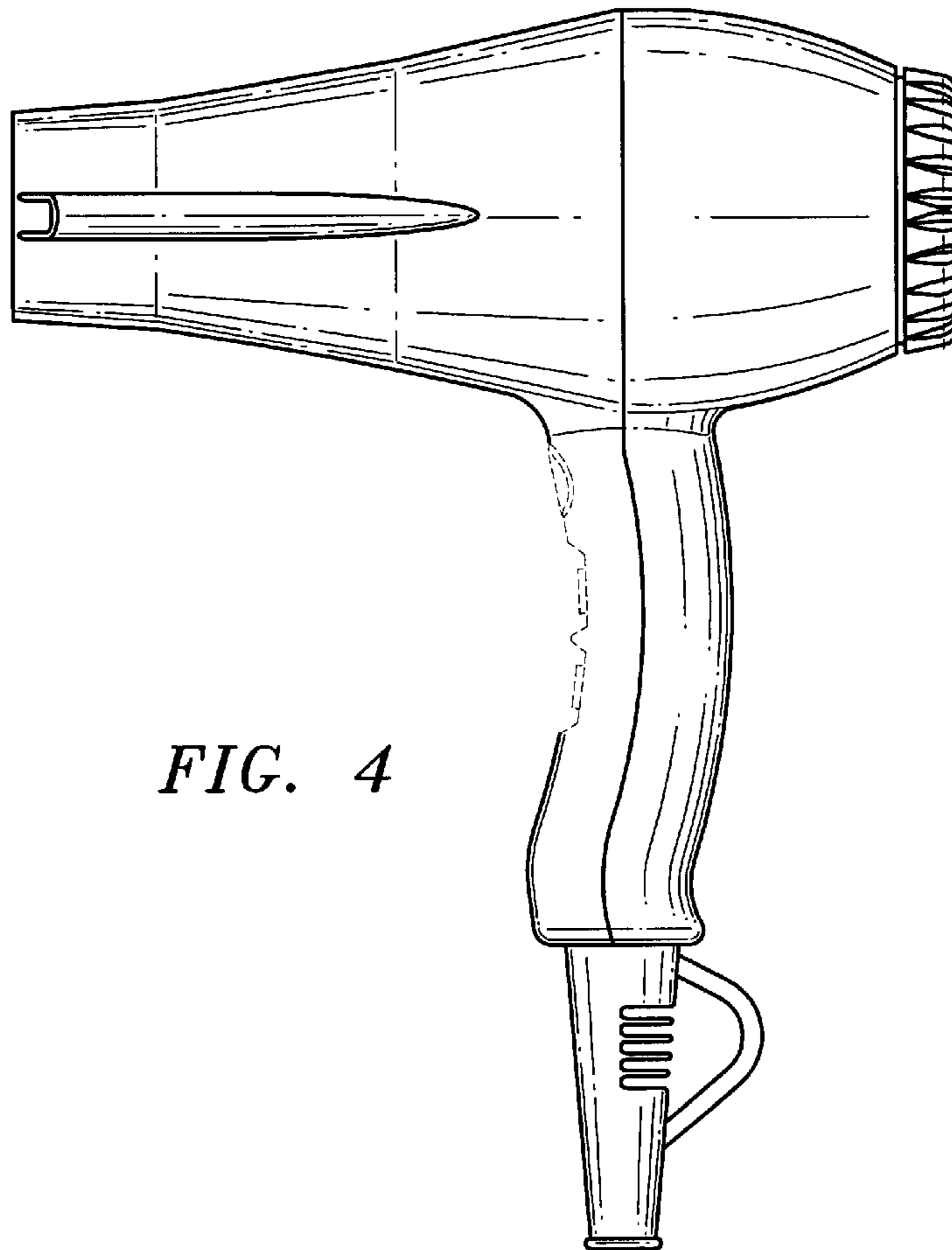

FIG. 3



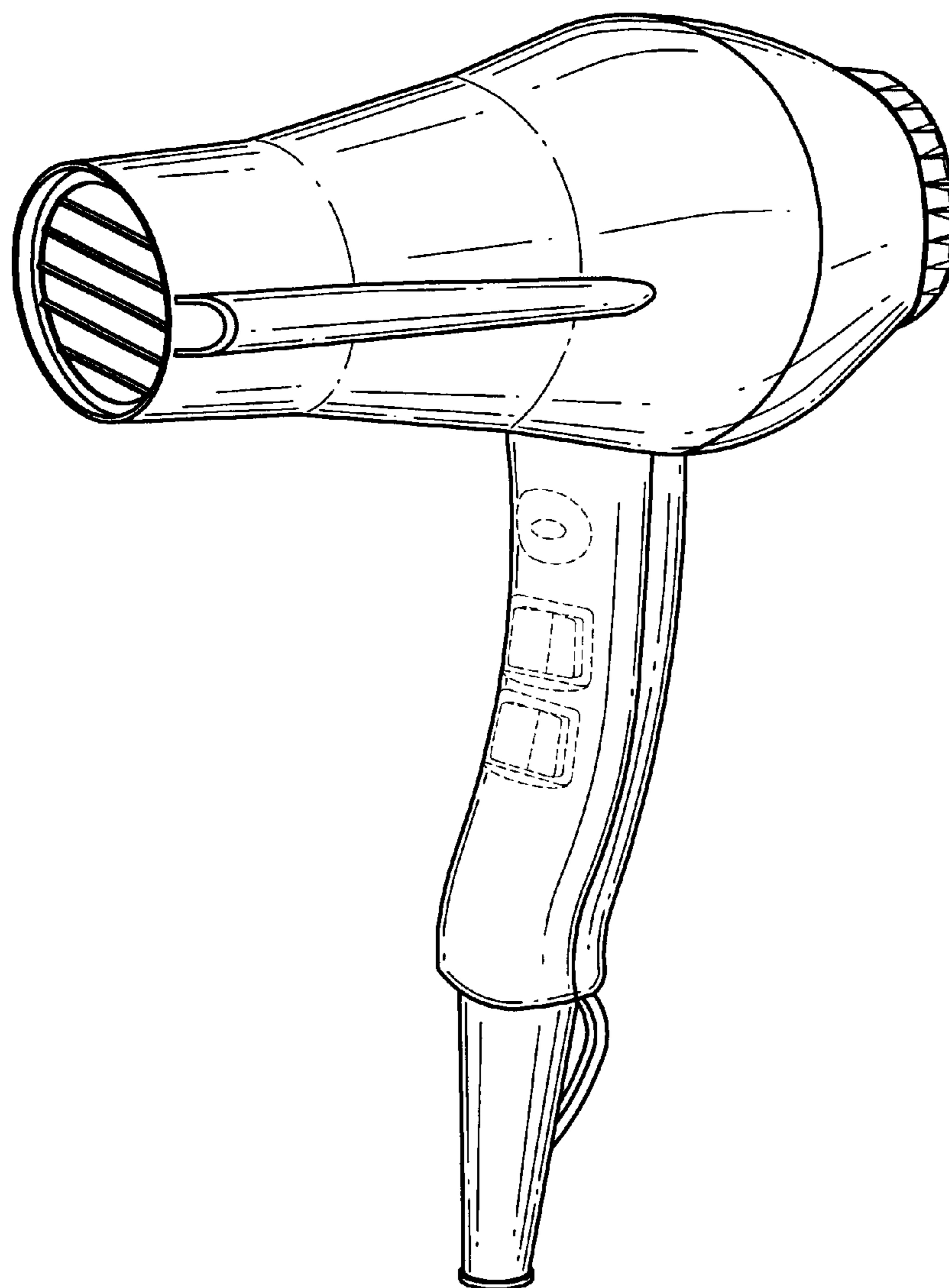

FIG. 6