



US00D528545S

(12) **United States Design Patent**  
**Crews**

(10) **Patent No.:** **US D528,545 S**

(45) **Date of Patent:** **\*\* Sep. 19, 2006**

(54) **CONTROLLER**

(75) **Inventor:** **Lewis Jeremy Crews, Richmond, VA (US)**

(73) **Assignee:** **Linear Devices Corporation, Richmond, VA (US)**

(\*\*) **Term:** **14 Years**

(21) **Appl. No.:** **29/234,889**

(22) **Filed:** **Jul. 25, 2005**

(51) **LOC (8) Cl.** ..... **14-02**

(52) **U.S. Cl.** ..... **D14/401**

(58) **Field of Classification Search** ..... D14/399-401;  
D21/324, 328; 273/148 B; 463/36-47; 200/5 R,  
200/5 A, 6 R, 6 A; 345/156-167; 74/471 XY  
See application file for complete search history.

(56) **References Cited**

**U.S. PATENT DOCUMENTS**

5,059,958 A	*	10/1991	Jacobs et al.	.....	345/158
5,207,426 A	*	5/1993	Inoue et al.	.....	463/36
D356,607 S	*	3/1995	Feng	.....	D14/401
D366,911 S	*	2/1996	Hsieh	.....	D14/401
D373,149 S	*	8/1996	Kawasaki	.....	D14/401
5,624,117 A	*	4/1997	Ohkubo et al.	.....	273/148 B

5,643,087 A	*	7/1997	Marcus et al.	.....	463/38
5,645,277 A	*	7/1997	Cheng	.....	273/148 B
5,667,220 A	*	9/1997	Cheng	.....	273/148 B
5,759,100 A	*	6/1998	Nakanishi	.....	463/37
D405,079 S	*	2/1999	Oikawa	.....	D14/401
D416,247 S	*	11/1999	Flender et al.	.....	D14/401
D516,073 S	*	2/2006	Boswell et al.	.....	D14/399

\* cited by examiner

*Primary Examiner*—Prabhakar Deshmukh

(74) *Attorney, Agent, or Firm*—John H. Thomas, P.C.

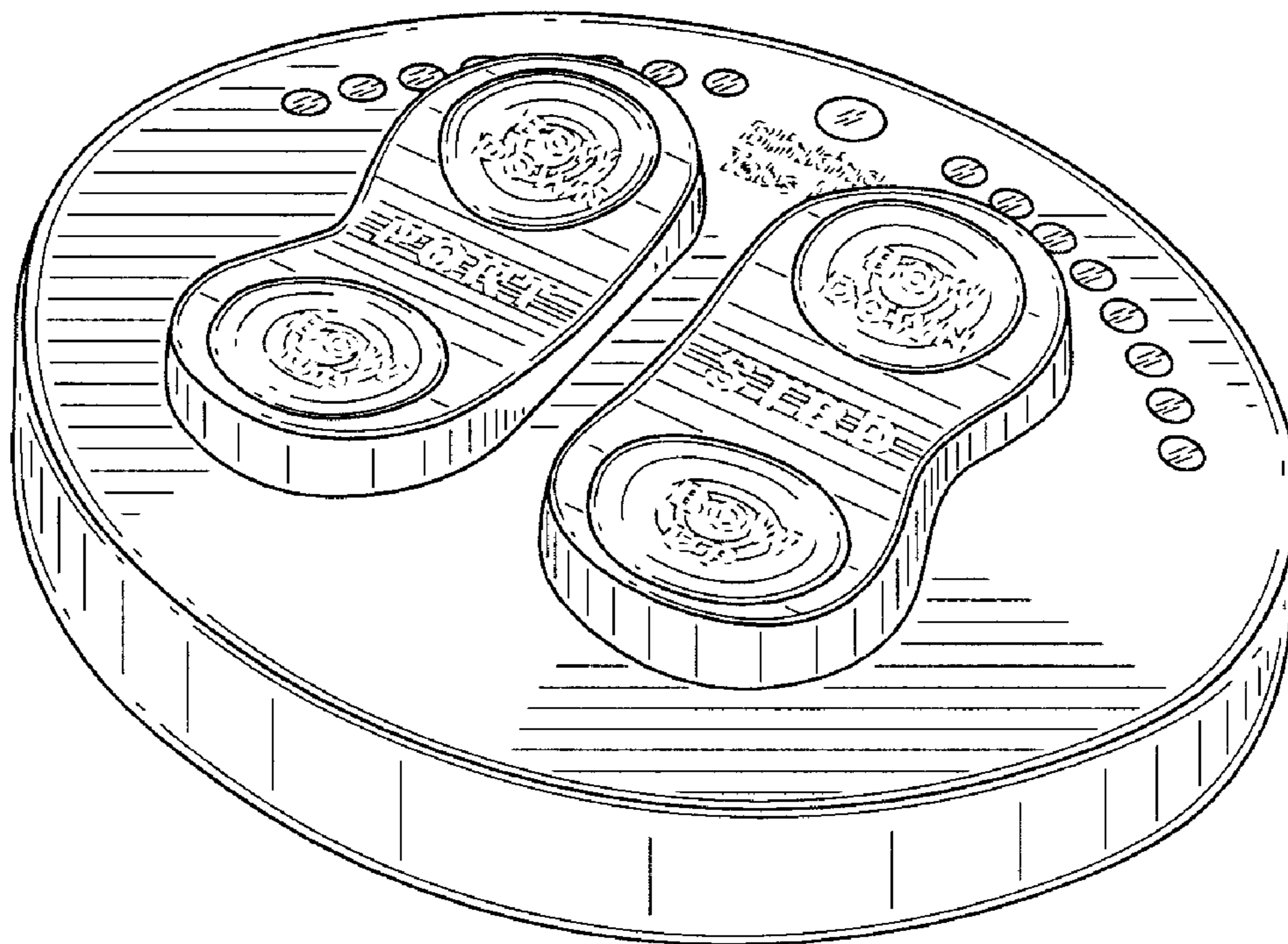
(57) **CLAIM**

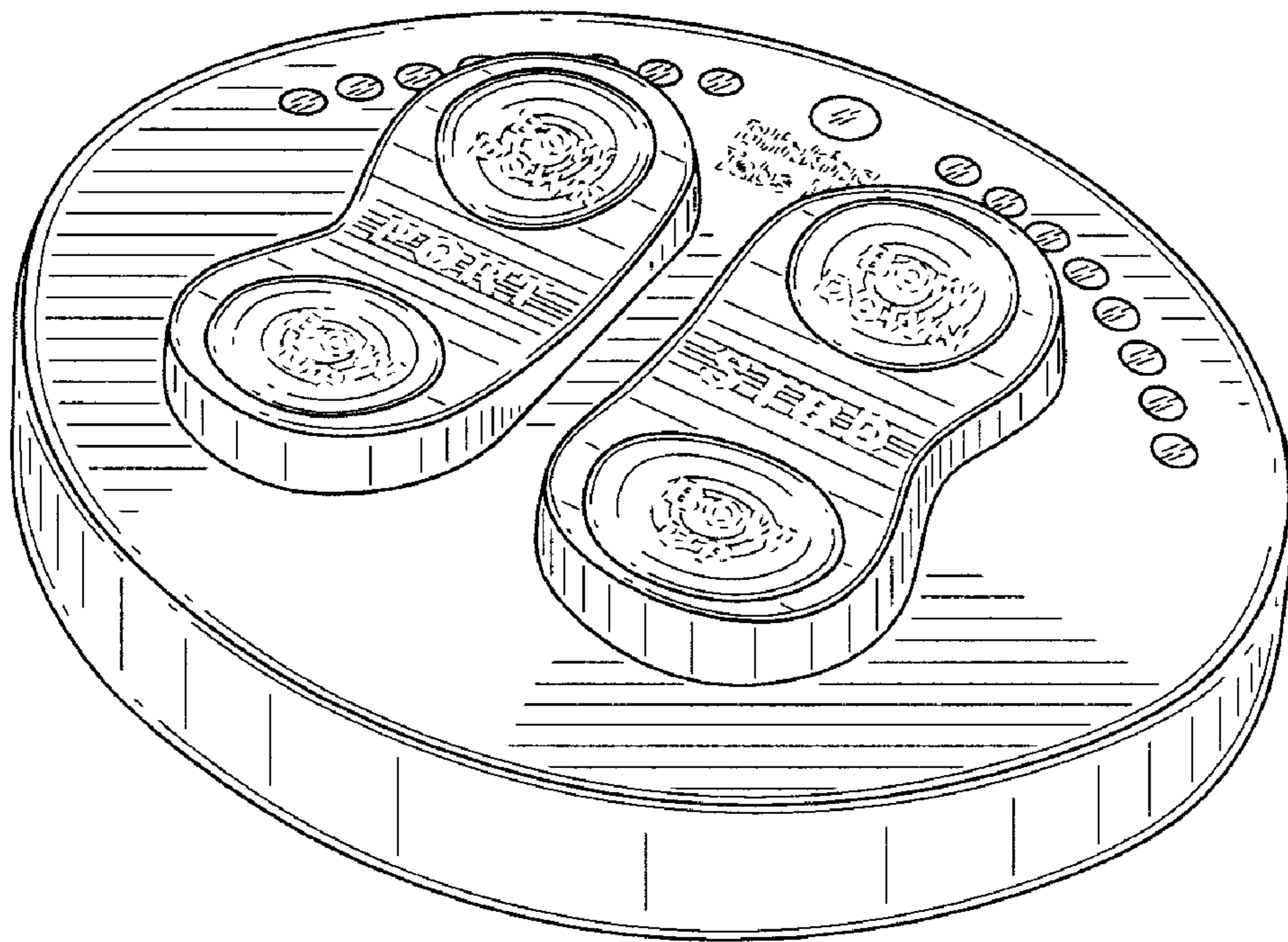
The ornamental design for a controller, a shown and described.

**DESCRIPTION**

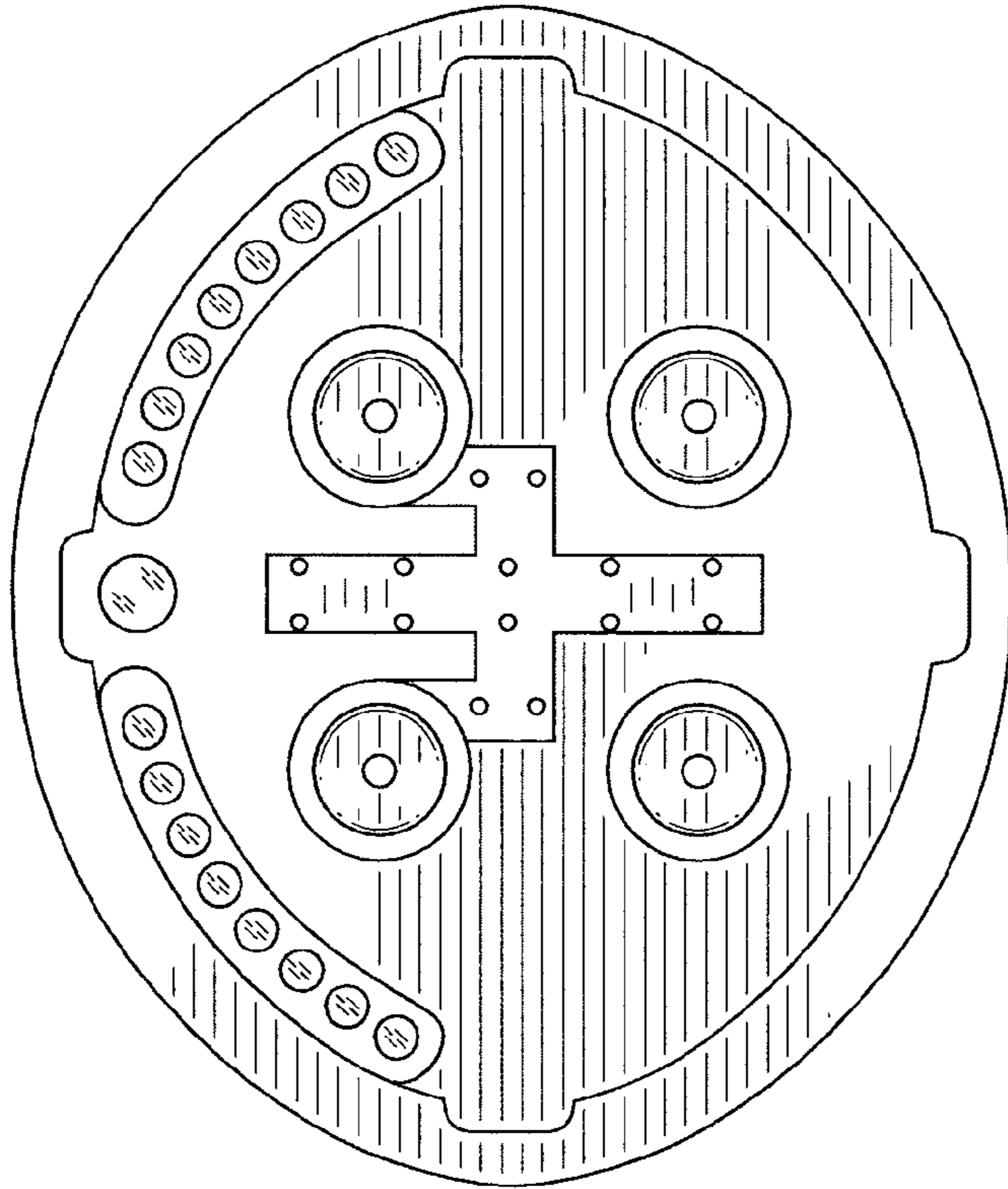
FIG. 1 is a perspective view of a controller showing my new design;  
 FIG. 2 is a top plan view thereof;  
 FIG. 3 is a bottom plan view thereof;  
 FIG. 4 is a right side elevational view thereof; and,  
 FIG. 5 is a front elevational view thereof.  
 The broken lines, which define the bounds of the claimed design form no part thereof.  
 The broken lines environmental are for illustrative purposes only and form no part of the claimed design.

**1 Claim, 3 Drawing Sheets**

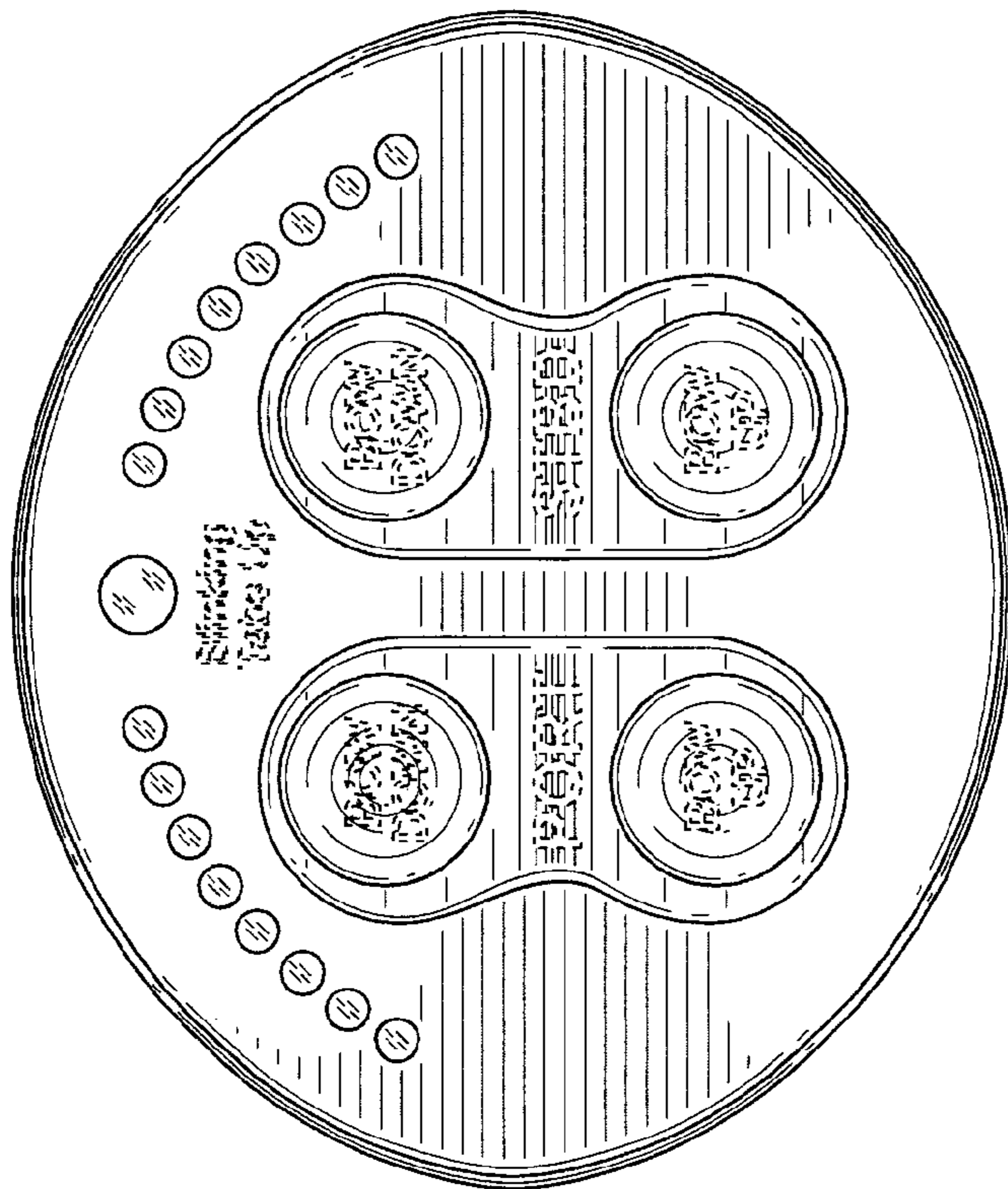




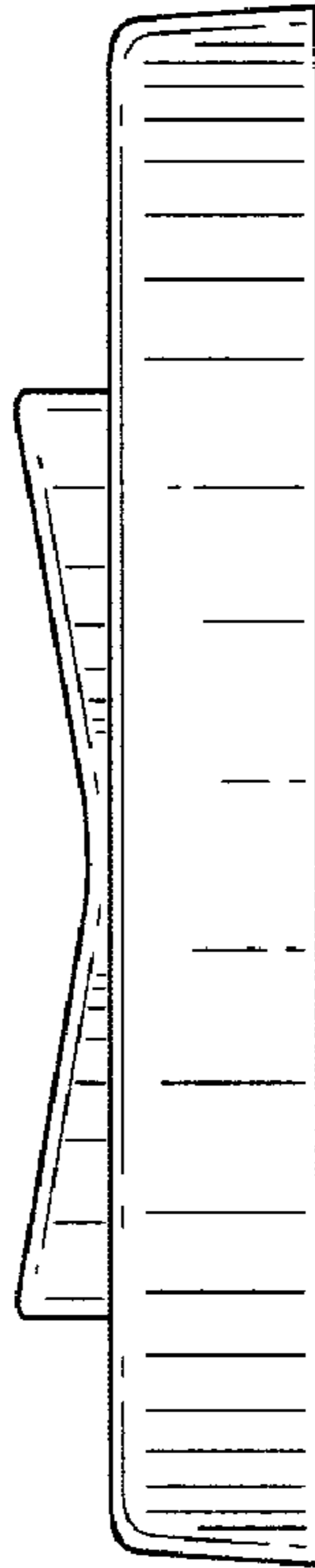
**FIG. 1**



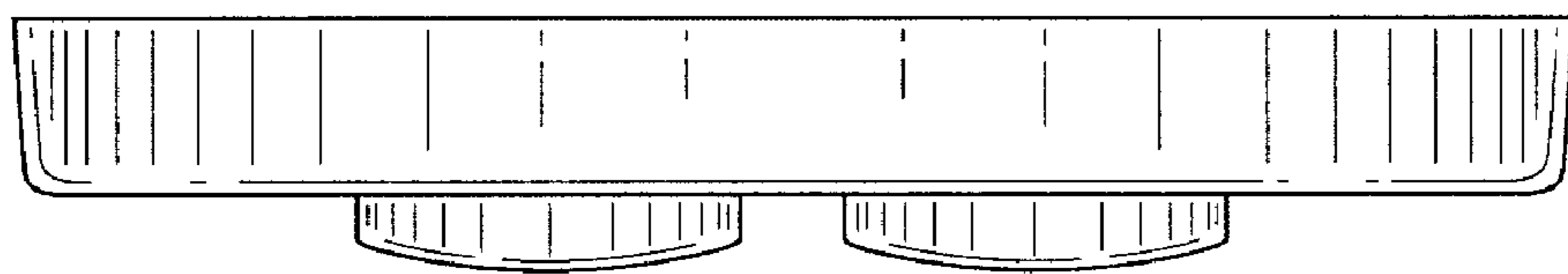
**FIG. 2**



**FIG. 3**



**FIG. 4**



**FIG. 5**