



US00D528503S

(12) **United States Design Patent**
Tang

(10) **Patent No.:** **US D528,503 S**

(45) **Date of Patent:** **** Sep. 19, 2006**

(54) **BATTERY PACK FOR COMBINED
ELECTRIC PEPPER AND SALT MILL**

(75) **Inventor:** **Wing Sum Tang, Kowloon (HK)**

(73) **Assignee:** **Samson Bright Industrial Company
Limited, Kowloon (HK)**

(**) **Term:** **14 Years**

(21) **Appl. No.:** **29/237,606**

(22) **Filed:** **Sep. 2, 2005**

(51) **LOC (8) Cl.** **13-02**

(52) **U.S. Cl.** **D13/103**

(58) **Field of Classification Search** D13/102-106,
D13/110, 118-119, 184; D7/679; 429/96-100,
429/163, 176

See application file for complete search history.

(56) **References Cited**

U.S. PATENT DOCUMENTS

267,025	A	*	11/1882	See	607/145
D32,450	S	*	4/1900	Seeger et al.	D13/103
2,876,273	A	*	3/1959	Hall	429/100
D231,990	S	*	7/1974	Peasley	D13/119
D263,581	S	*	3/1982	Kaye	D13/103
4,644,244	A	*	2/1987	Kittelson	320/100

5,122,427	A	*	6/1992	Flowers et al.	429/97
D345,727	S	*	4/1994	Flowers et al.	D13/103
D361,980	S	*	9/1995	Chen	D13/119
D376,579	S	*	12/1996	Bunyea et al.	D13/103
D384,031	S	*	9/1997	Lui	D13/103
D387,328	S	*	12/1997	Ueda	D13/103
D388,060	S	*	12/1997	Tanaka et al.	D13/103
5,709,963	A	*	1/1998	Sim	429/99
D508,236	S	*	8/2005	Duke et al.	D13/184

* cited by examiner

Primary Examiner—Alan P. Douglas

Assistant Examiner—Rosemary K. Tarcza

(74) *Attorney, Agent, or Firm*—Merchant & Gould P.C.

(57) **CLAIM**

The ornamental design for a battery pack for combined electric pepper and salt mill, as shown and described.

DESCRIPTION

FIG. 1 is a front view of a battery pack for combined electric pepper and salt mill showing my new design;
FIG. 2 is a rear view thereof;
FIG. 3 is a left side view thereof;
FIG. 4 is a right side view thereof;
FIG. 5 is a top end view thereof; and,
FIG. 6 is a bottom end view thereof.

1 Claim, 5 Drawing Sheets

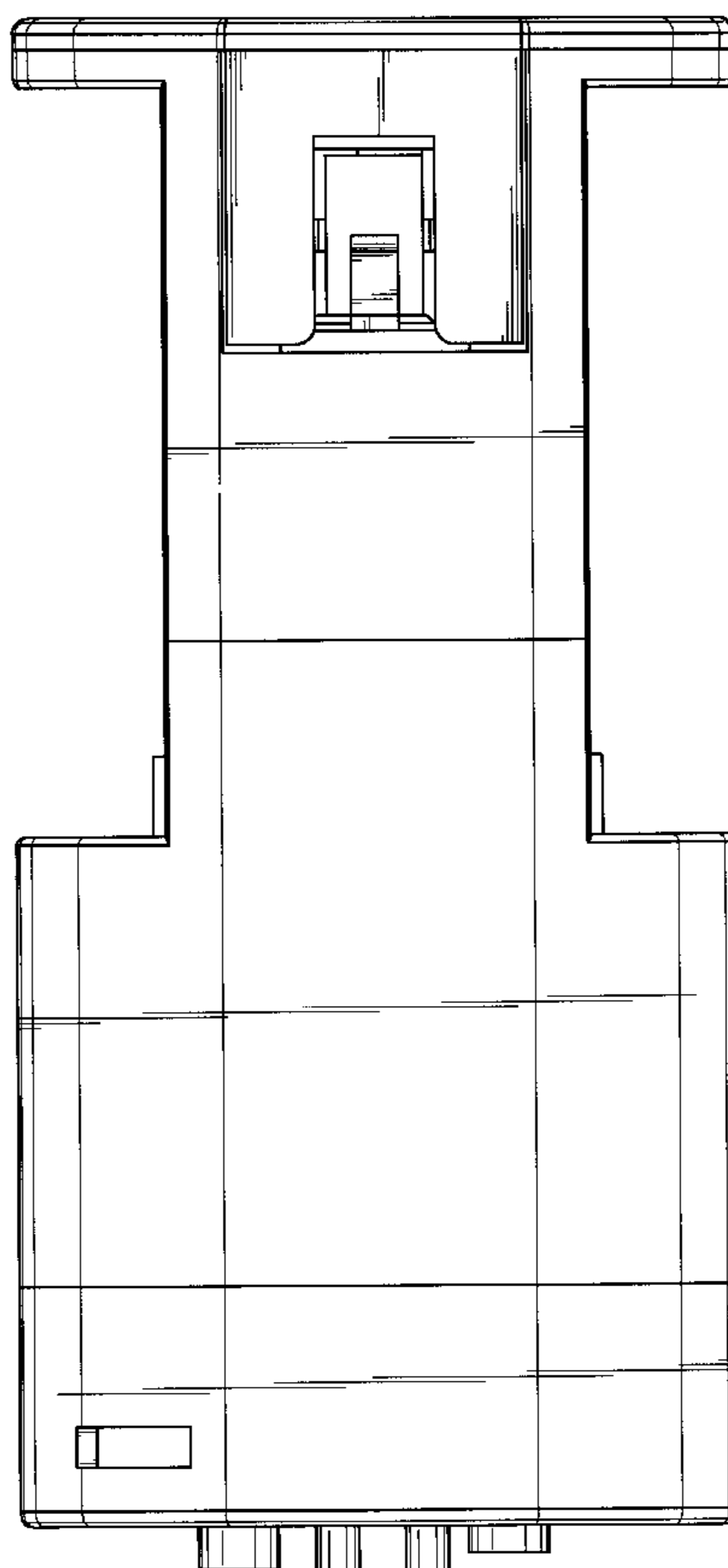

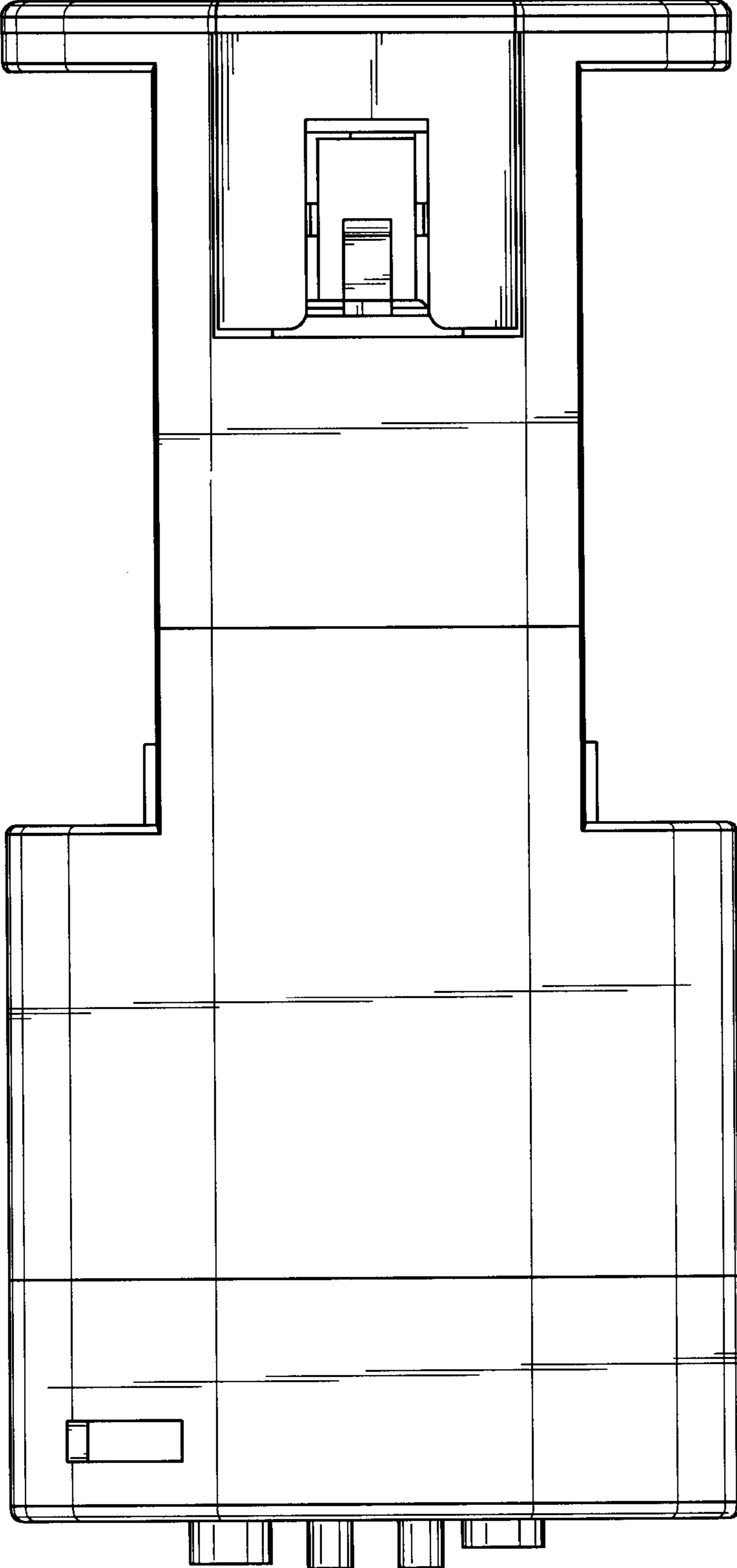

FIG. 1

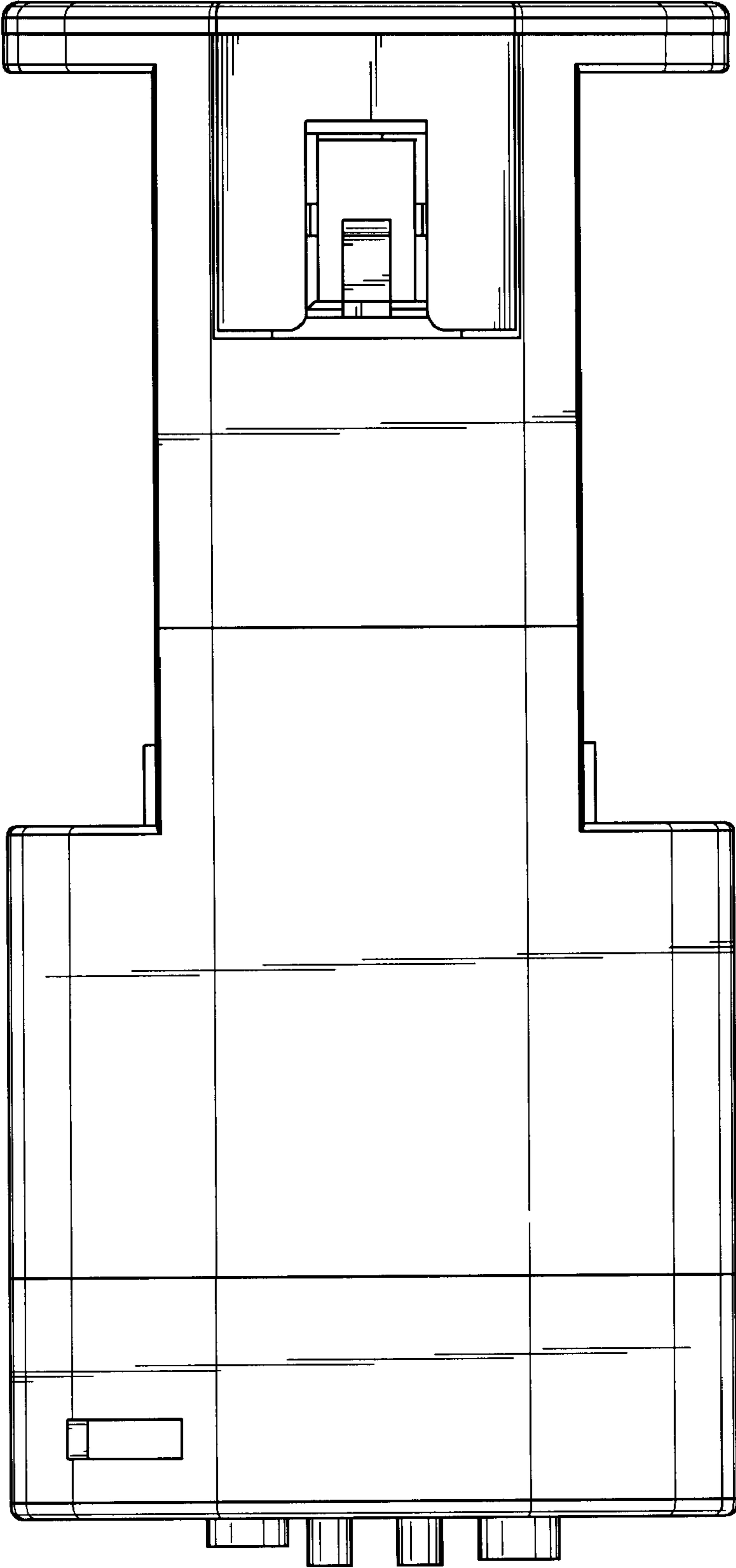

FIG. 2

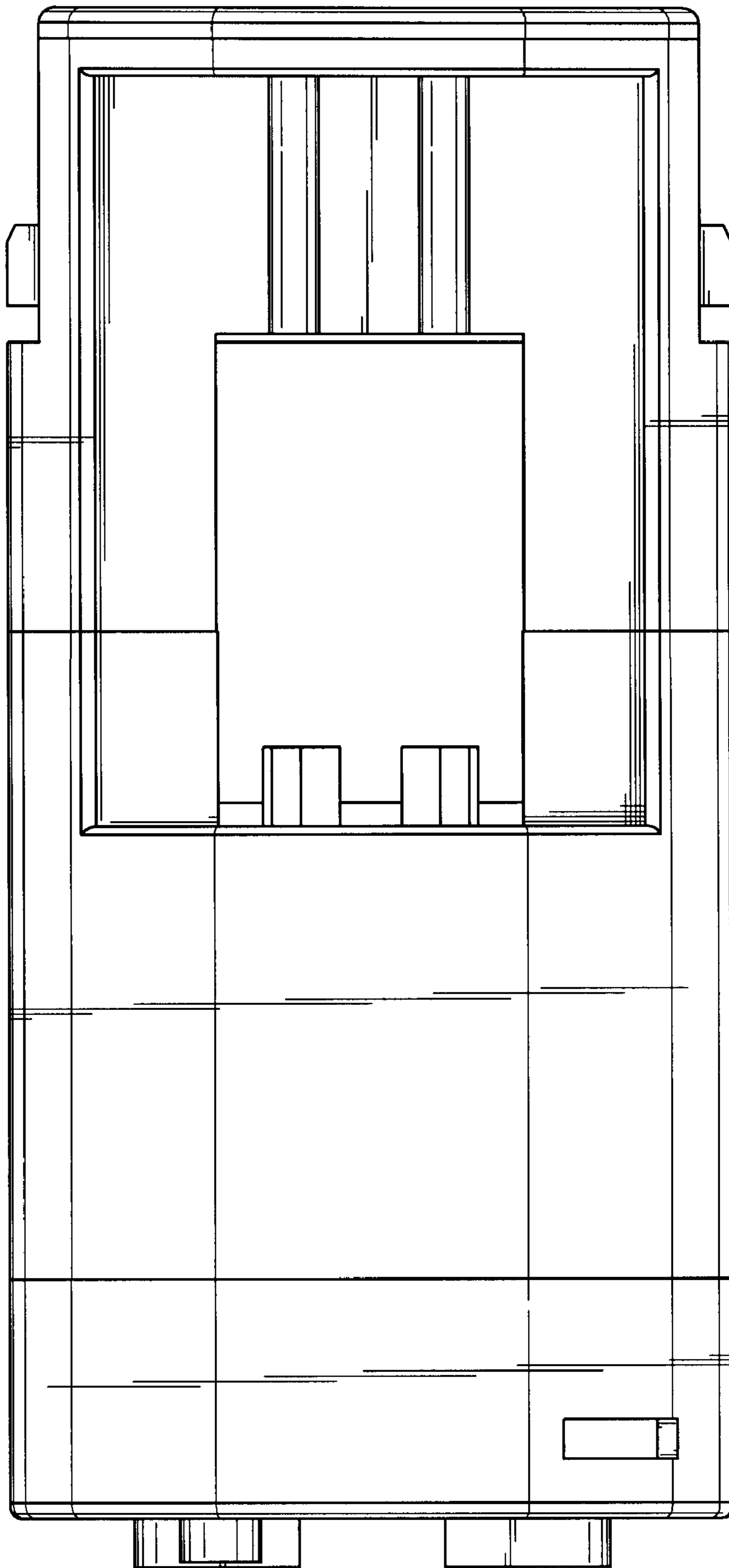

FIG. 3

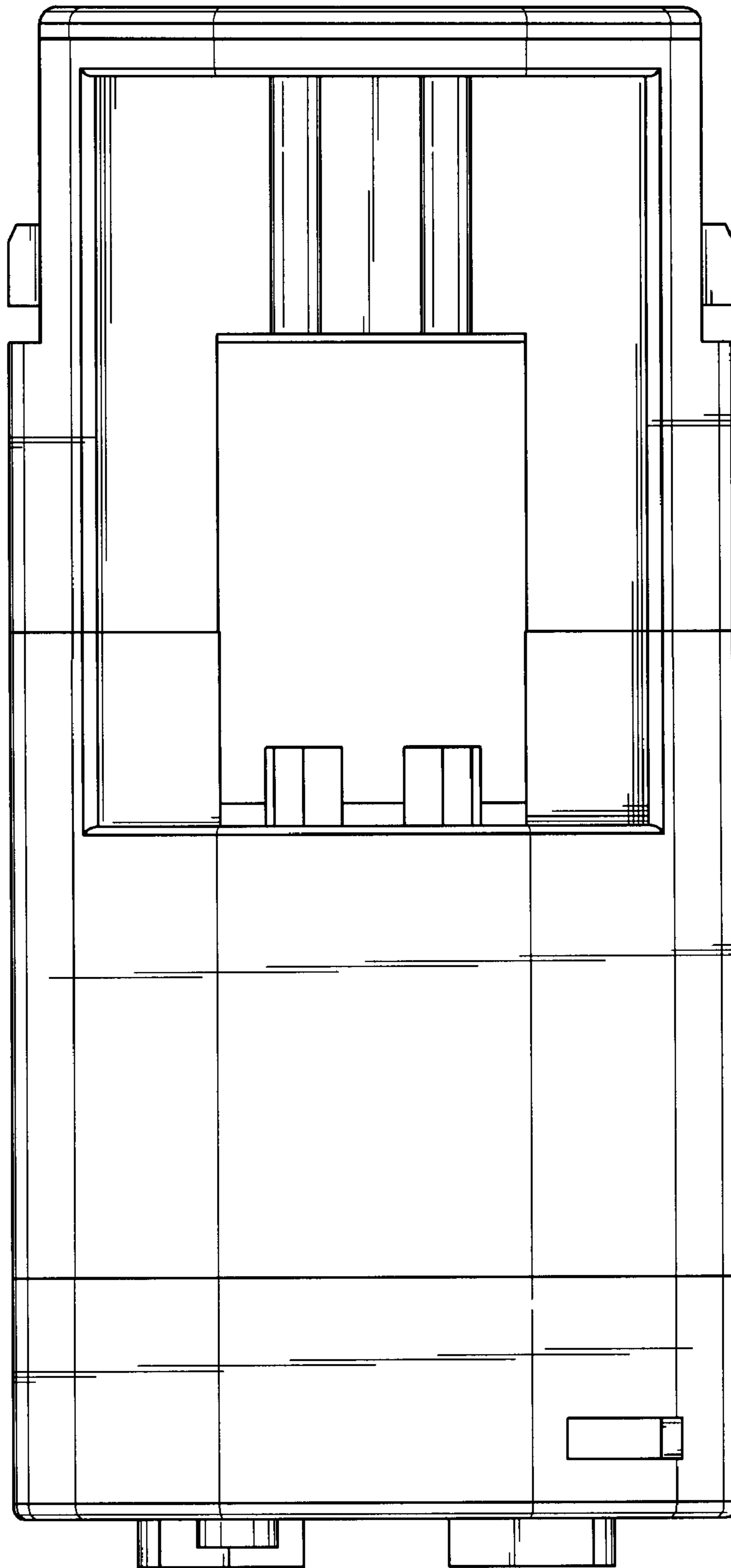

FIG. 4

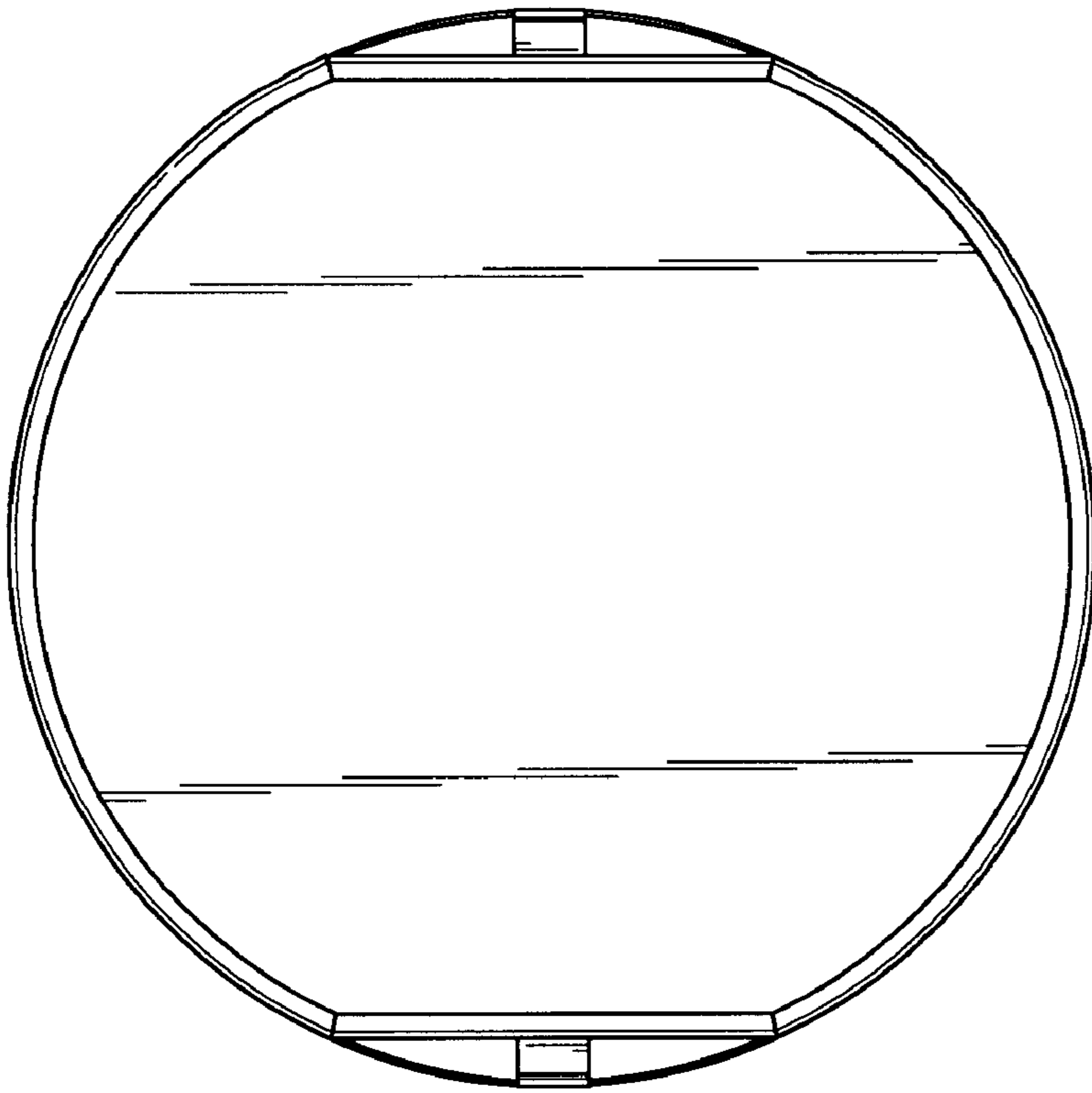

FIG. 5

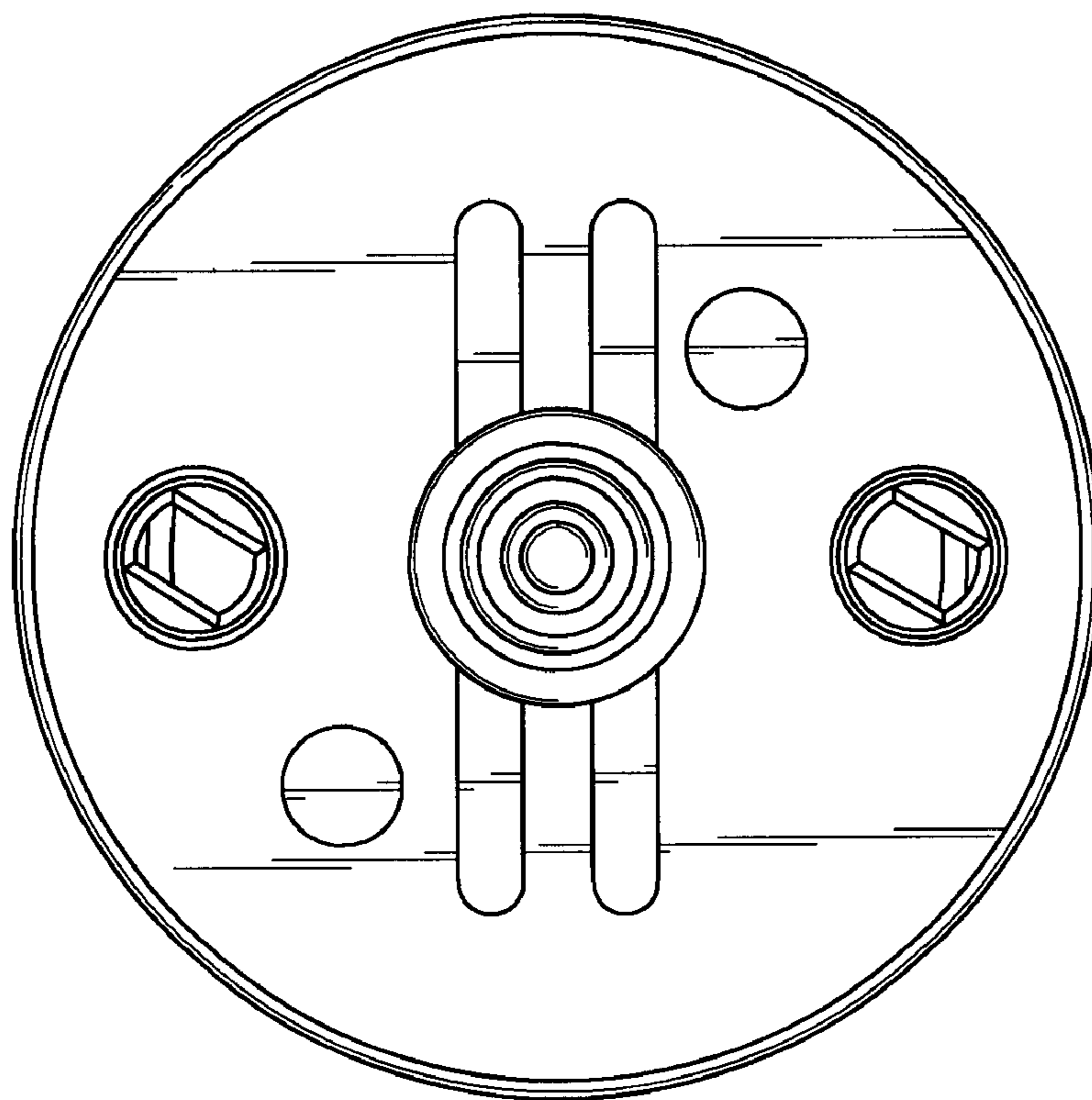

FIG. 6