



US00D528328S

(12) **United States Design Patent**
Cassaday

(10) **Patent No.:** **US D528,328 S**

(45) **Date of Patent:** **** Sep. 19, 2006**

(54) **SHAPED LEVERS**

(75) Inventor: **Terry Cassaday**, Toronto (CA)

(73) Assignee: **Ergo-Industrial Seating Systems Ltd.**,
Ontario (CA)

(**) Term: **14 Years**

(21) Appl. No.: **29/202,920**

(22) Filed: **Apr. 8, 2004**

(51) **LOC (8) Cl.** **06-06**

(52) **U.S. Cl.** **D6/500**

(58) **Field of Classification Search** D6/334-336,
D6/364, 365, 366, 367, 379, 491, 500-502;
248/161, 188.1; 297/300.1, 300.2, 300.8,
297/301.1, 301.4, 301.6, 302.1, 302.4, 302.5,
297/302.7, 310, 344.18, 344.19, 344.21,
297/344.22, 463.1

See application file for complete search history.

(56) **References Cited**

U.S. PATENT DOCUMENTS

4,662,680	A	*	5/1987	Dauphin	297/300.3
D292,459	S	*	10/1987	Doerner	D6/500
5,066,069	A	*	11/1991	DeGelder	297/374
5,356,200	A	*	10/1994	Stumpf et al.	297/328
D374,779	S	*	10/1996	Feldberg	D6/366
D376,924	S	*	12/1996	Beaulieu	D6/366
D378,170	S	*	2/1997	Beaulieu	D6/366
5,601,337	A	*	2/1997	Choda et al.	297/302.1
D378,714	S	*	4/1997	Beaulieu	D6/366
5,664,834	A	*	9/1997	Hsu	297/300.1
D395,366	S	*	6/1998	Favaretto	D6/366
D400,018	S	*	10/1998	James et al.	D6/366
D405,968	S	*	2/1999	Beaulieu	D6/366
D405,969	S	*	2/1999	Beaulieu	D6/366
D409,404	S	*	5/1999	Kaczmarek	D6/366

(Continued)

Primary Examiner—Mimosa De

(74) *Attorney, Agent, or Firm*—Eugene J.A. Gierczak

(57) **CLAIM**

The ornamental design for the shaped levers, as shown and described.

DESCRIPTION

FIG. 1 is a perspective view of a first embodiment of the shaped levers showing the chair in phantom lines.

FIG. 2 is a perspective view of the shaped levers shown in FIG. 1 taken from a point above said shaped levers.

FIG. 3 is a perspective view of the shaped levers shown in FIG. 1 taken from a view below said shaped levers.

FIG. 4 is a side elevational view taken from the right of FIG. 2.

FIG. 5 is a front end elevational view of FIG. 2.

FIG. 6 is a side elevational view taken from the left of FIG. 2.

FIG. 7 is a rear end elevational view of FIG. 2.

FIG. 8 is a top plan view of FIG. 2.

FIG. 9 is a bottom plan view of FIG. 2.

FIG. 10 is a perspective view of a second embodiment of the design.

FIG. 11 is a perspective view of a third embodiment of the design.

FIG. 12 is a perspective view of a fourth embodiment of the design.

FIG. 13 is a perspective view of a fifth embodiment of the design taken from a point above the shaped levers.

FIG. 14 is a perspective view of the fifth embodiment of the design taken from a point below the shaped levers.

FIG. 15 is a side elevational view from the right of FIG. 13.

FIG. 16 is a front end view of FIG. 13.

FIG. 17 is side elevational view of FIG. 13 taken from the left of FIG. 13.

FIG. 18 is a rear end elevational view of FIG. 13.

FIG. 19 is a top plan view of FIG. 13.

FIG. 20 is a bottom plan view of FIG. 13.

FIG. 21 is a perspective view of a sixth embodiment of the design.

FIG. 22 is a perspective view of a seventh embodiment of the design; and,

FIG. 23 is a perspective view of an eight embodiment of the design.

1 Claim, 7 Drawing Sheets

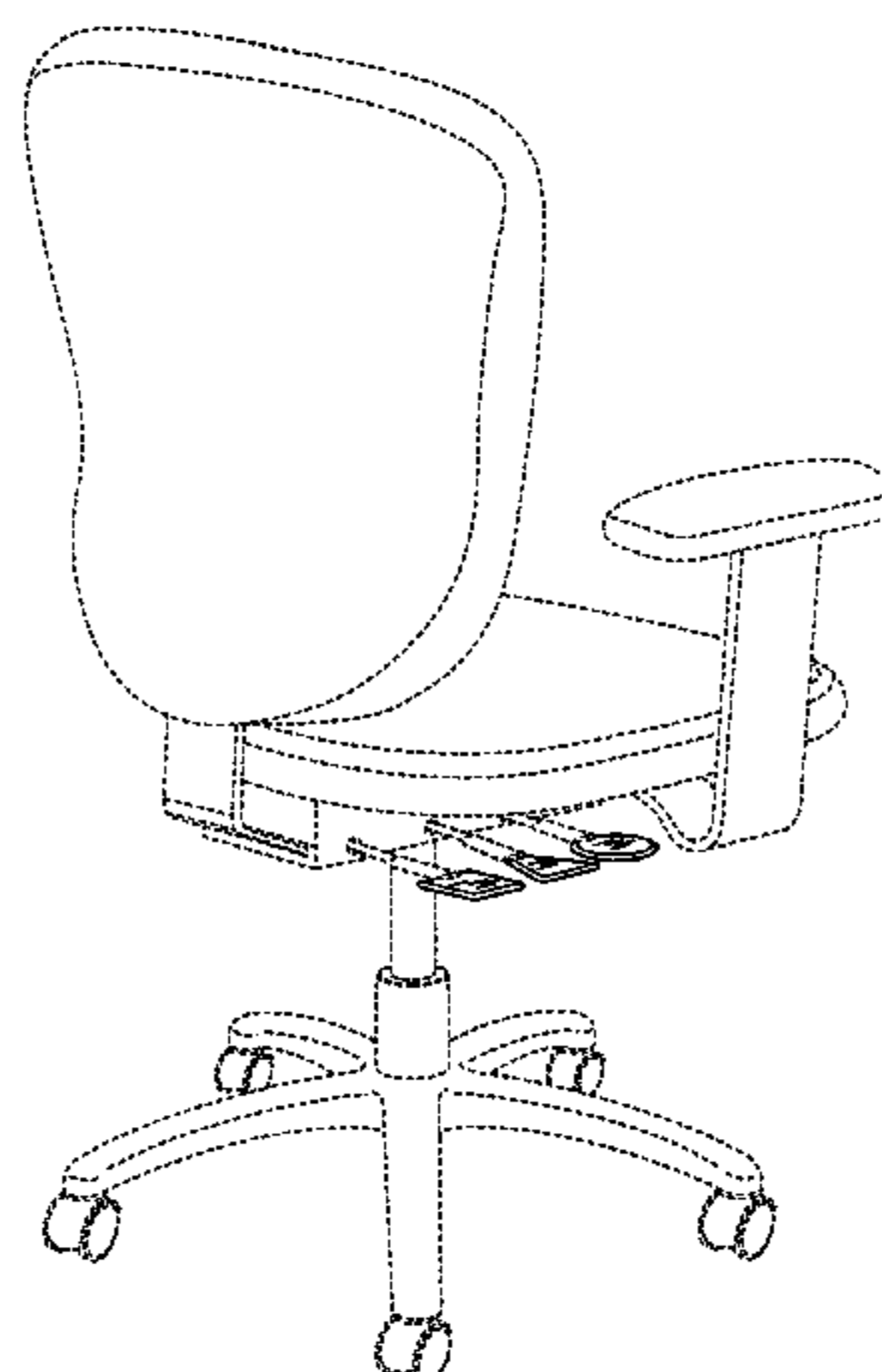

US D528,328 S

Page 2

U.S. PATENT DOCUMENTS

D409,862 S	*	5/1999	Glaser et al.	D6/500	6,619,740 B1	*	9/2003	Beggs	297/300.1
6,131,997 A	*	10/2000	Cao	297/344.22	D483,582 S	*	12/2003	Chen	D6/500
6,131,998 A	*	10/2000	Su	297/374	6,916,067 B1	*	7/2005	Liu	297/300.8
D433,852 S	*	11/2000	Zhou	D6/500	6,923,502 B1	*	8/2005	Cassaday	297/217.3
D446,033 S	*	8/2001	Koepke et al.	D6/366	7,008,022 B1	*	3/2006	Cassaday	297/463.1
D447,652 S	*	9/2001	Beggs	D6/500	7,017,992 B1	*	3/2006	Stumpf	297/301.7
6,290,296 B1	*	9/2001	Beggs	297/344.16	2002/0139906 A1	*	10/2002	Pan	248/188.1
D461,976 S	*	8/2002	Koepke et al.	D6/500	2003/0184144 A1	*	10/2003	Matern et al.	297/463.1
D470,351 S	*	2/2003	Patton	D6/500	2005/0146196 A1	*	7/2005	Cassaday	297/463.1
D472,081 S	*	3/2003	Chen	D6/500						

* cited by examiner

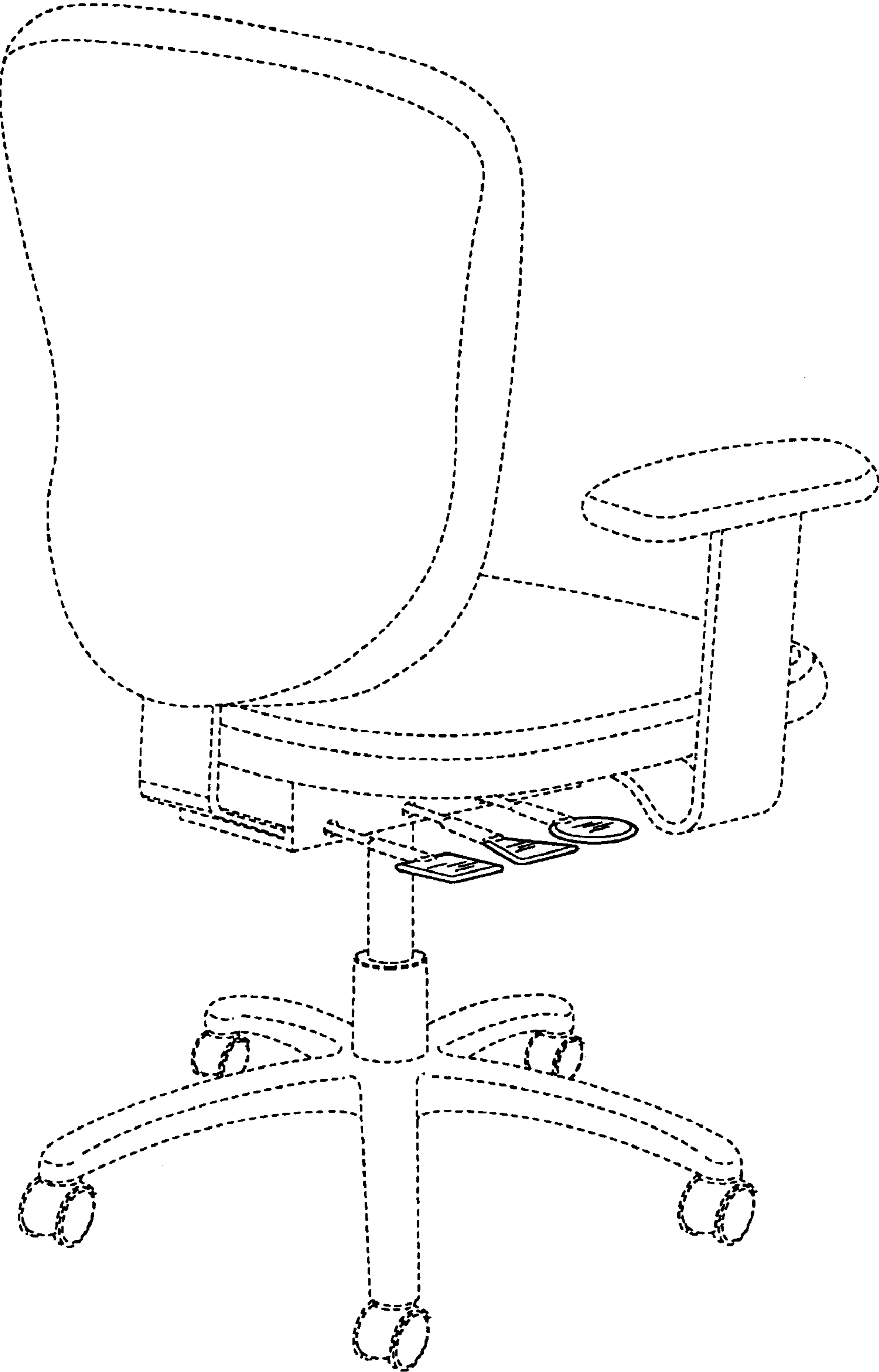

FIG. 1

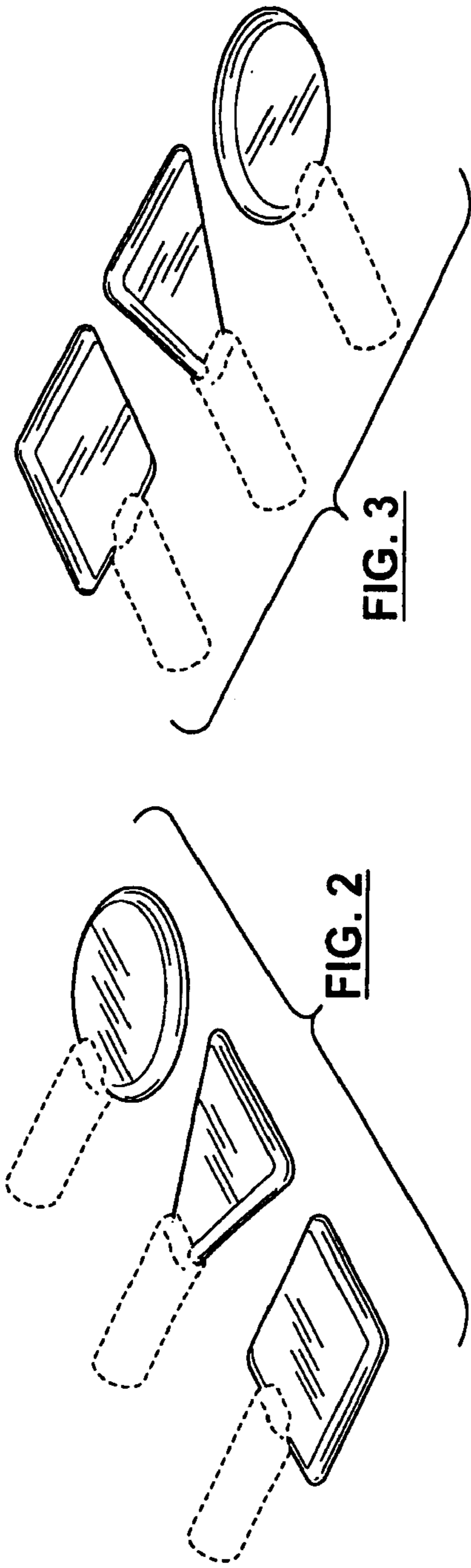

FIG. 3

FIG. 2

FIG. 6

FIG. 5

FIG. 4

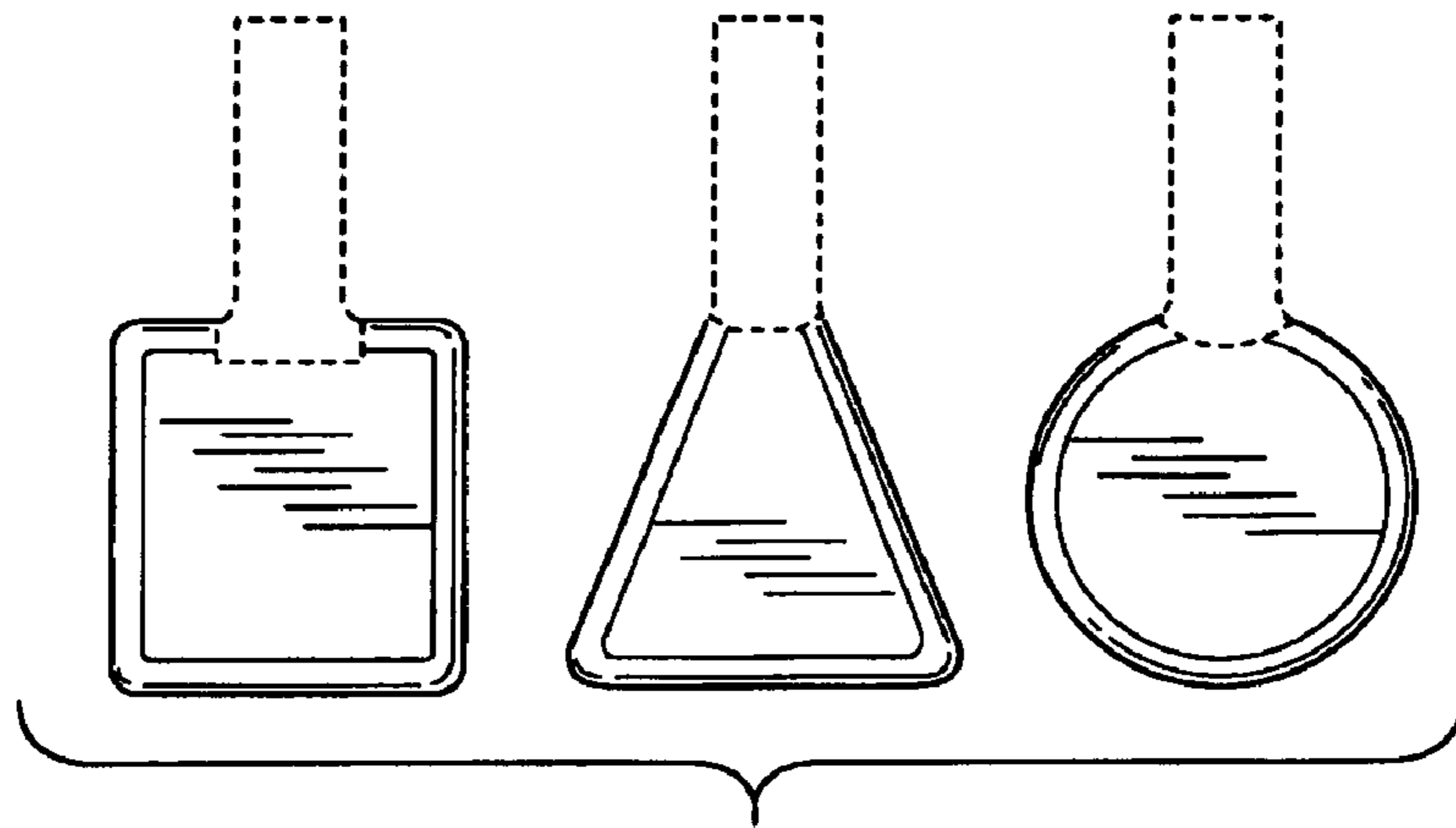

FIG. 8

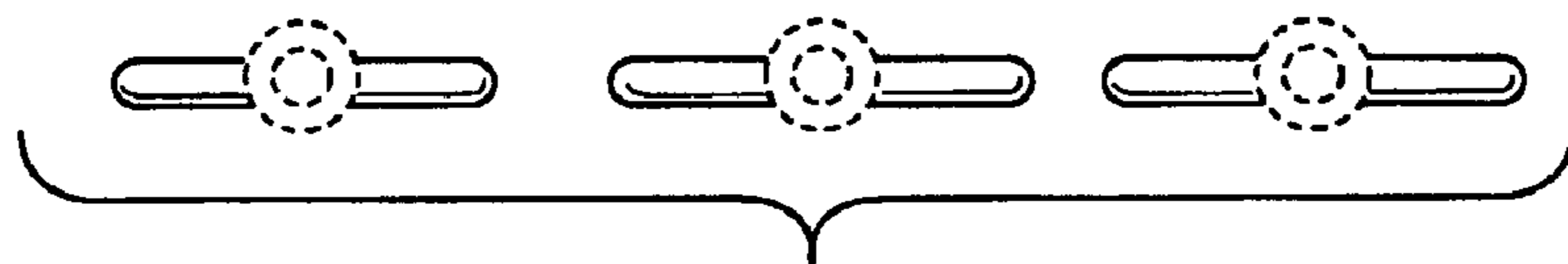

FIG. 7

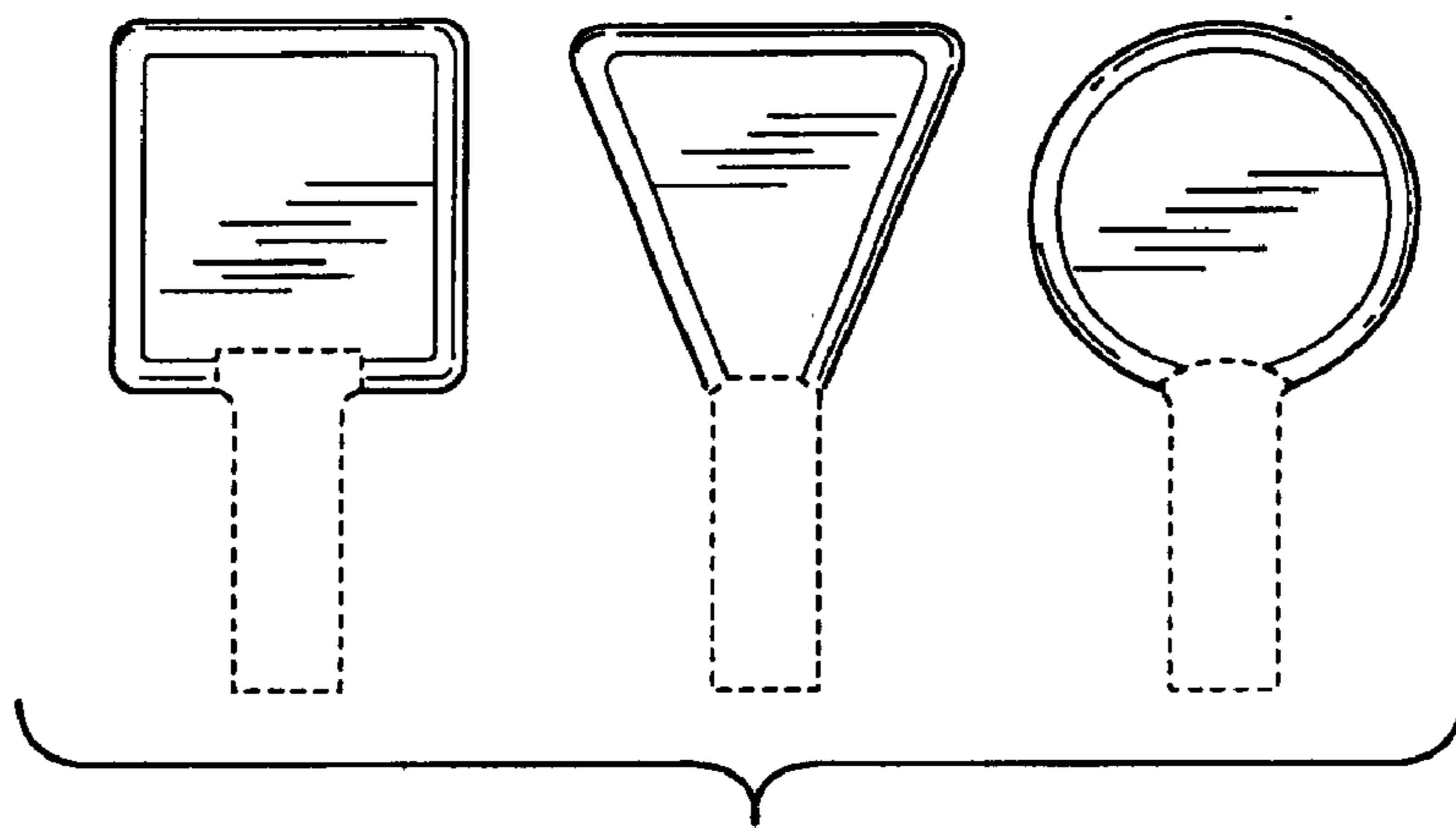
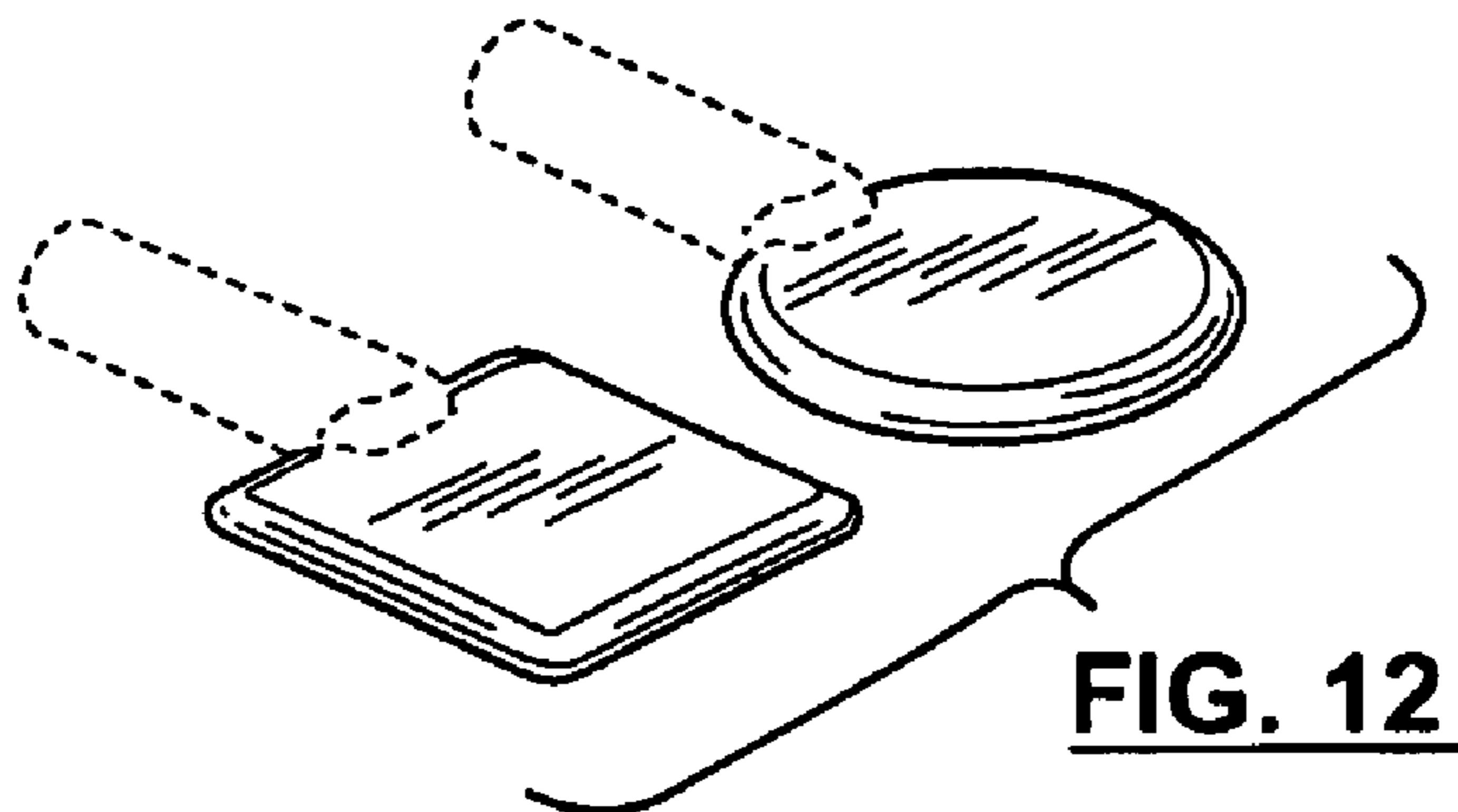
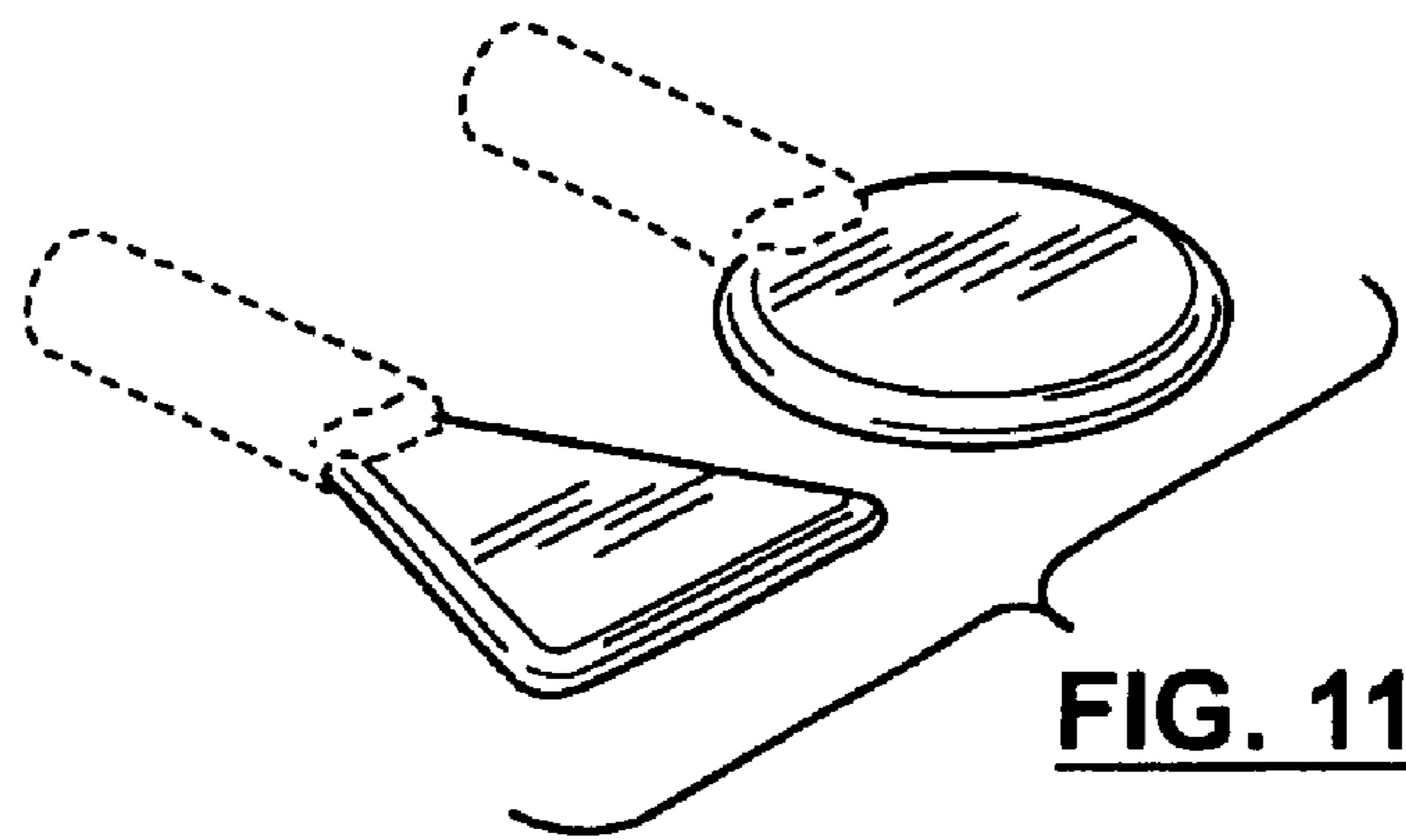
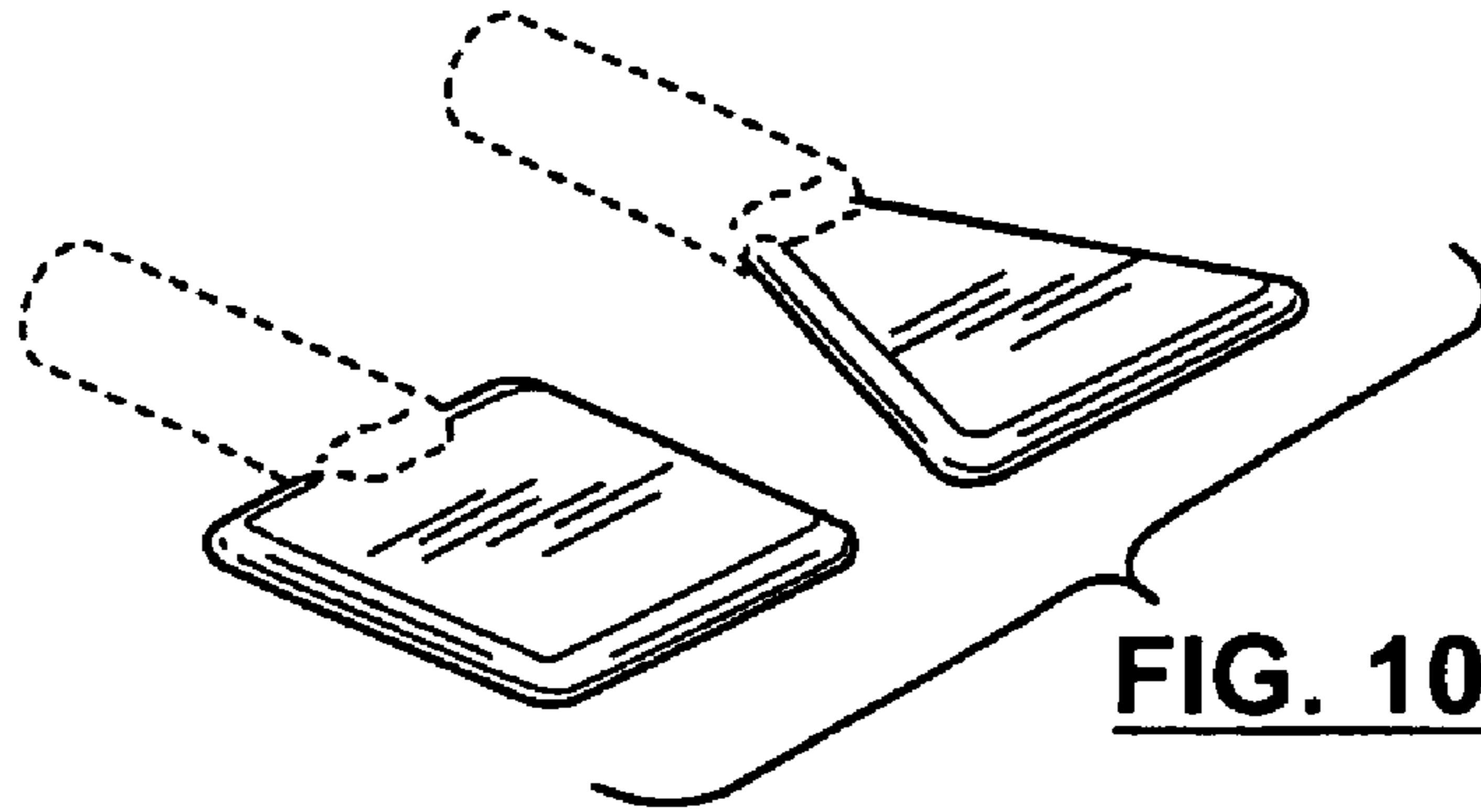

FIG. 9



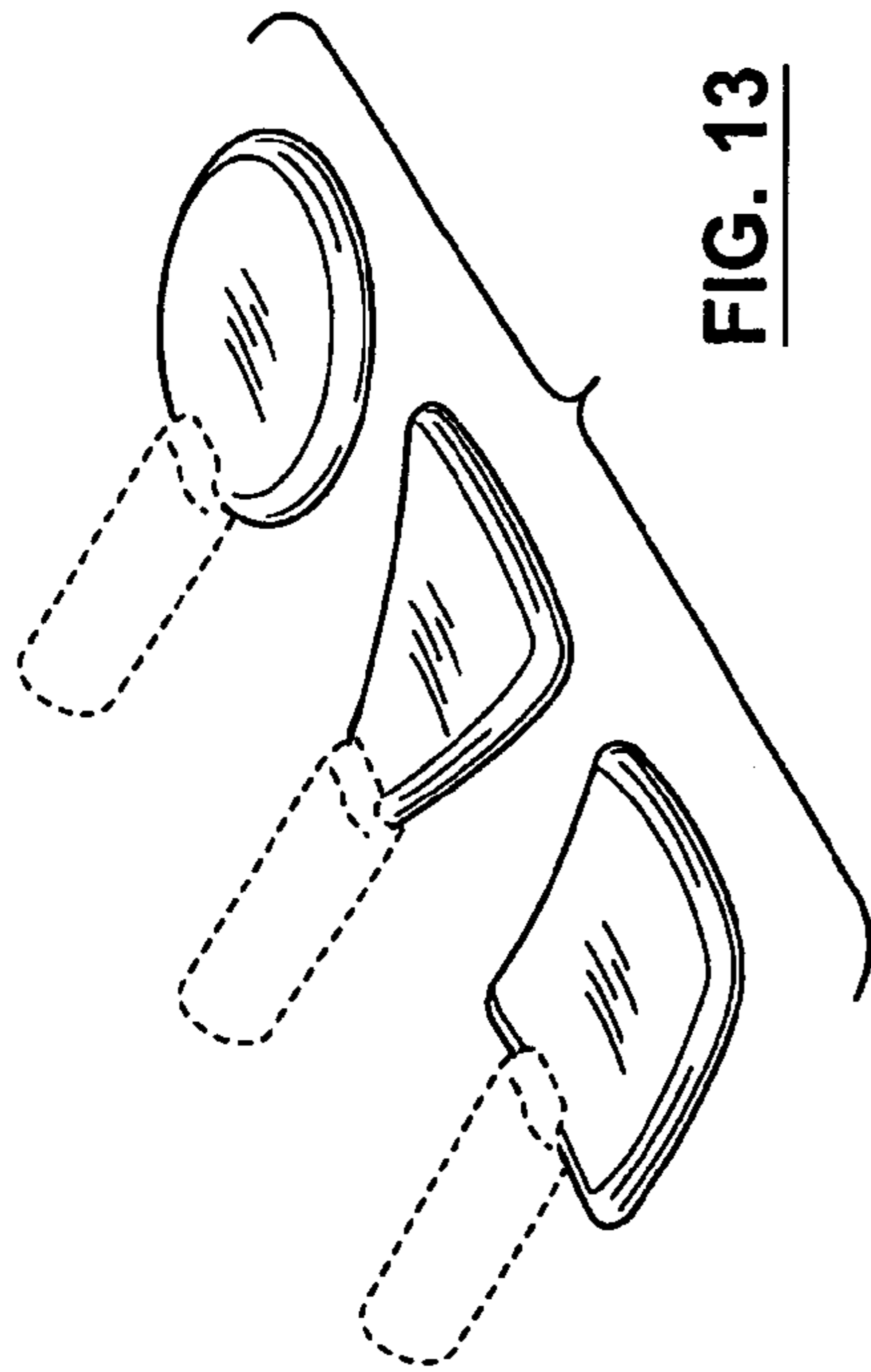

FIG. 13

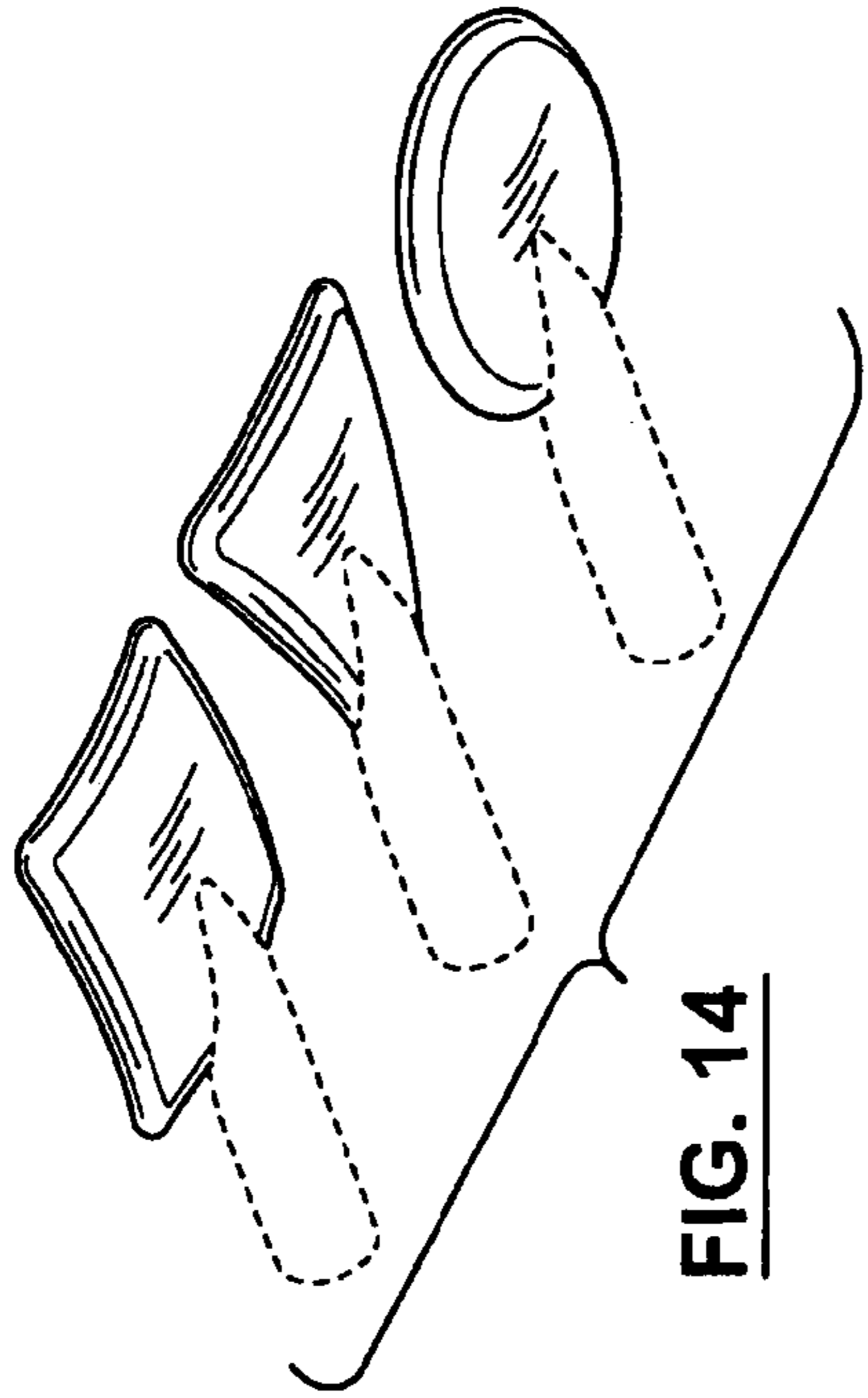

FIG. 14



FIG. 15

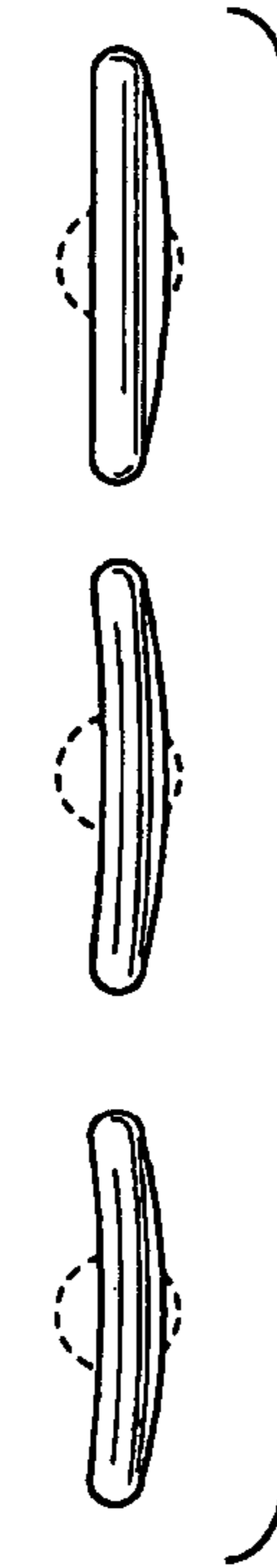

FIG. 16

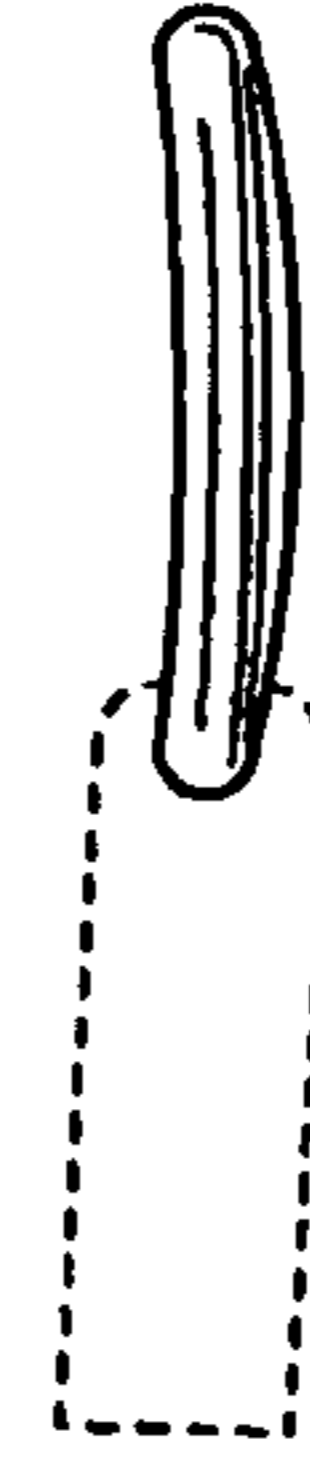

FIG. 17

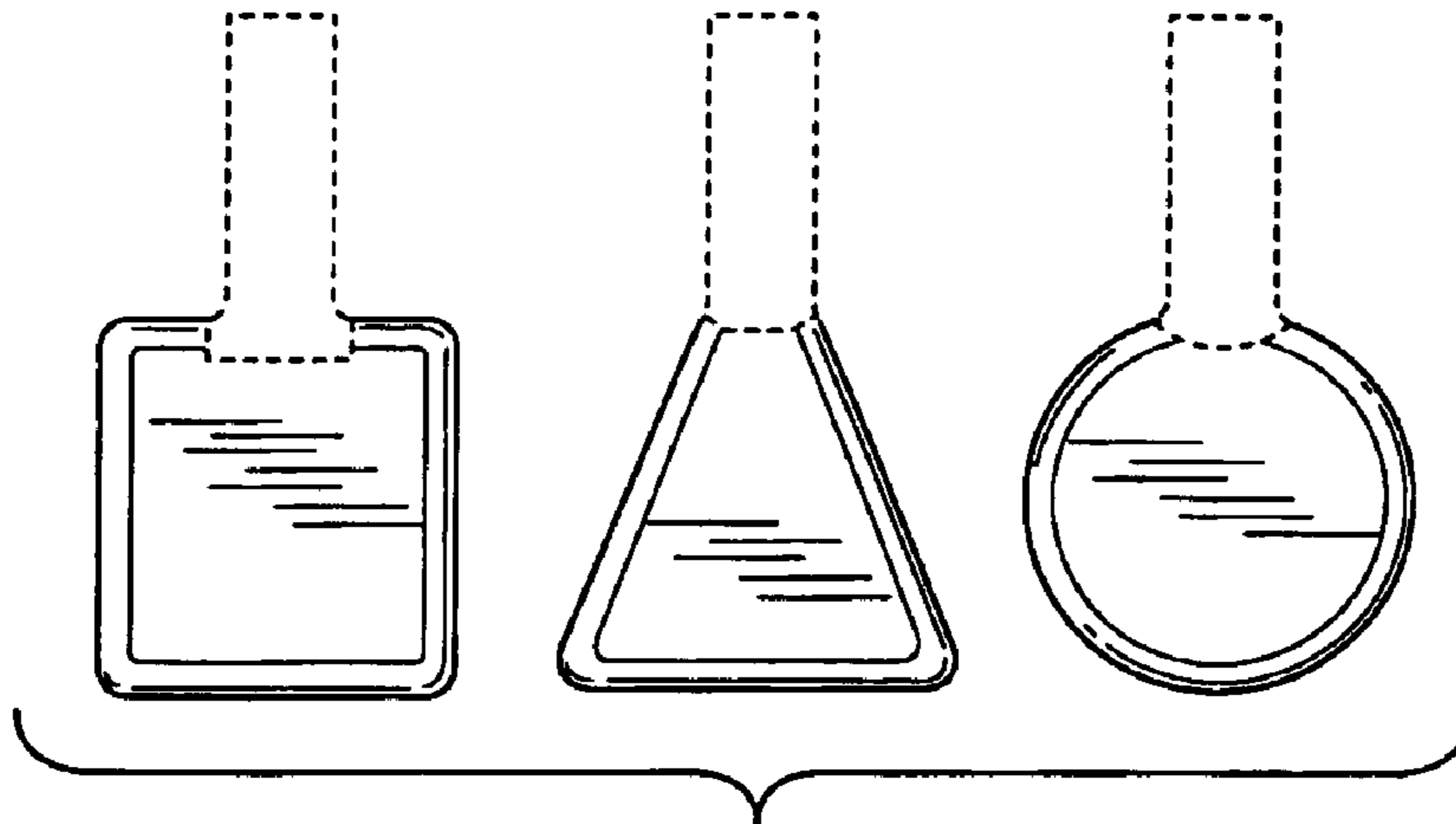

FIG. 19

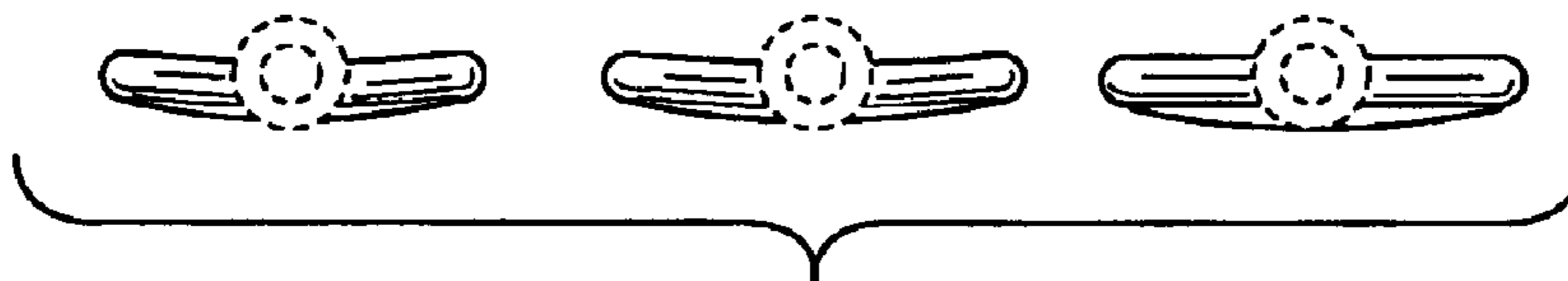

FIG. 18

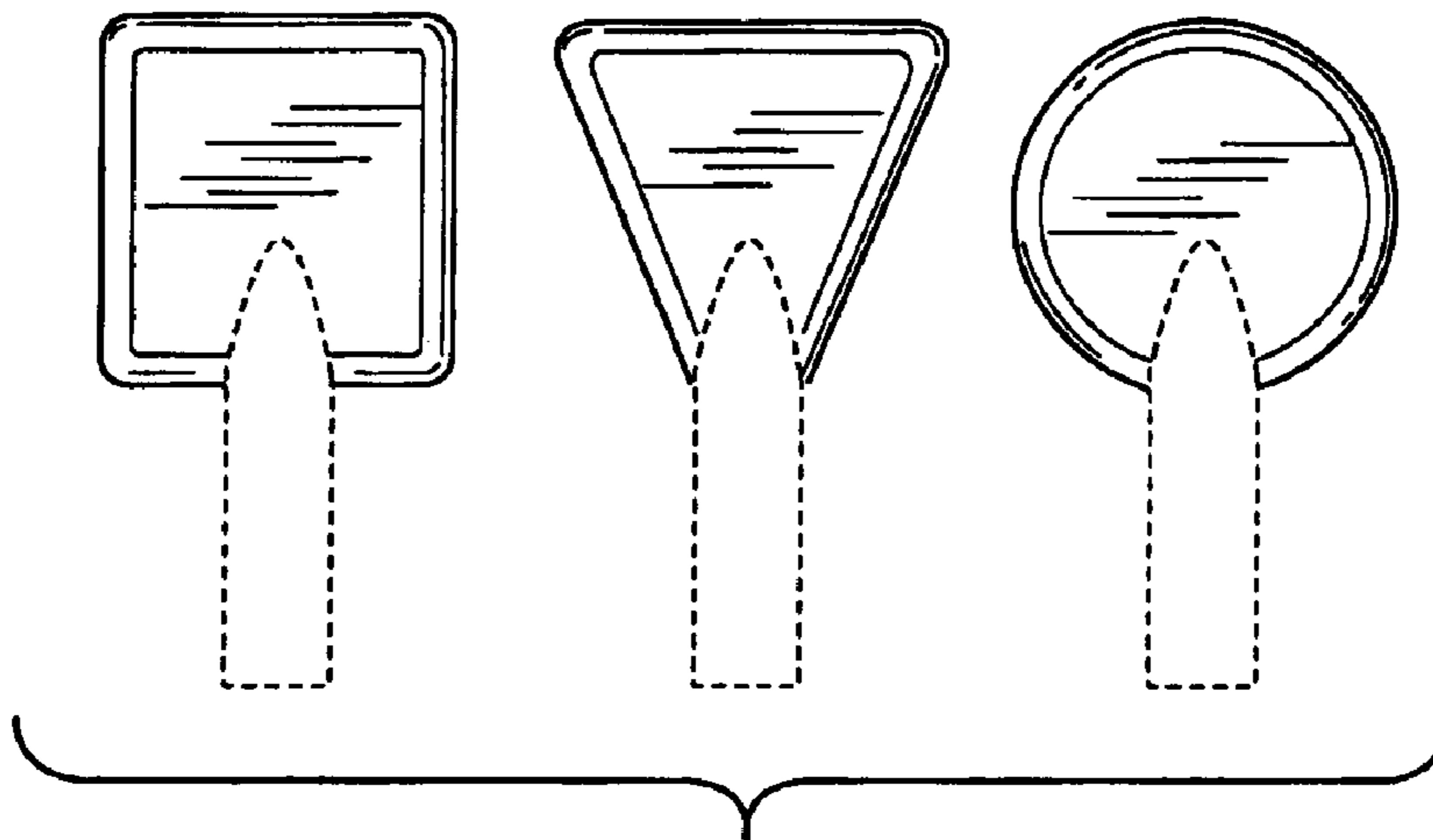

FIG. 20

