



US00D528127S

(12) **United States Design Patent** (10) **Patent No.:** **US D528,127 S**
Nagel et al. (45) **Date of Patent:** **** Sep. 12, 2006**

(54) **HOUSING OF THE ENGINE ASSEMBLY**

(75) Inventors: **John J. Nagel**, Hartford, WI (US);
John A. Zbiegien, Jr., Cedarburg, WI (US); **Daniel A. Matre**, Wauwatosa, WI (US)

(73) Assignee: **Briggs & Stratton Corporation**,
Wauwatosa, WI (US)

(**) Term: **14 Years**

(21) Appl. No.: **29/208,019**

(22) Filed: **Jun. 23, 2004**

(51) **LOC (8) Cl.** **15-01**

(52) **U.S. Cl.** **D15/1**

(58) **Field of Classification Search** D15/1-5,
D15/14-17, 149; D12/163-166; D13/112,
D13/184, 199; D34/15; 56/320.1-320.2;
180/89.1, 89.12; 46/36, 78, 39, 249; 74/606 R;
123/50-51 BD, 65 R, 56, 70 R, 198, 195.3,
123/667, 50 A, 50 B, 50 R, 51 R, 51 A,
123/41.7, 198 E, 306, 308, 661, 432, 56 B,
123/56 BA, 657, 56 BC, 52 R, 41.66, 311,
123/198.5, 41.67, 195 C, 56 A, 150 BA
See application file for complete search history.

(56) **References Cited**

U.S. PATENT DOCUMENTS

D379,995 S	*	6/1997	Gilmore	D15/1
D396,478 S	*	7/1998	Hubbach	D15/5
D471,207 S	*	3/2003	Kern et al.	D15/5
D479,244 S	*	9/2003	Kern et al.	D15/5
D490,818 S	*	6/2004	Hieke	D15/5

OTHER PUBLICATIONS

Ryobi Handheld Engine; on sale prior to Jul. 13, 2000.
Honda Handheld Engine; on sale prior to Jul. 13, 2000.
Robin Handheld Engine; on sale prior to Jul. 13, 2000.
Briggs & Stratton Corporation; 04 Engine Guide; Brochure;
2004; pp. 5-58 (excluding front & back cover pages);
Wauwatosa, Wisconsin.

KAWASAKI, Four-Cycle Engines, Kawasaki FJ180V, website, http://www.kawpowr.com/4cycle/fj180v_specs.html, 1 page, Feb. 2, 2005.

KAWASAKI, Four-Cycle Engines, Kawasaki FC290v, website, http://www.kawpowr.com/4cycle/fc290v_specs.html, 1 page, Feb. 2, 2005.

KAWASAKI, Four-Cycle Engines, Kawasaki FH721D, website, http://www.kawpowr.com/4cycle/fh721d_specs.html, 1 page, Feb. 2, 2005.

KAWASAKI, Four-Cycle Engines, Kawasaki FH601D, website, http://www.kawpowr.com/4cycle/fh601d_specs.html, 1 page, Feb. 2, 2005.

KAWASAKI, Four-Cycle Engines Kawasaki FH601V, website, http://www.kawpowr.com/4cycle/fh601v_specs.html, 1 page, Feb. 2, 2005.

(Continued)

Primary Examiner—Ian Simmons
Assistant Examiner—Maurice Stevens
(74) *Attorney, Agent, or Firm*—Michael Best & Friedrich LLP

(57) **CLAIM**

We claim the ornamental design for an housing of the engine assembly, as shown and described.

DESCRIPTION

FIG. 1 is a right side front perspective view of a housing of the engine assembly showing our new design;
FIG. 2 is a top view thereof;
FIG. 3 is a front view thereof;
FIG. 4 is a rear view thereof;
FIG. 5 is a left side thereof;
FIG. 6 is a right side thereof; and,
FIG. 7 is a bottom view thereof.
The broken lines define the environment and the boundaries of the claimed design and do not form any part of the claimed design.

1 Claim, 7 Drawing Sheets

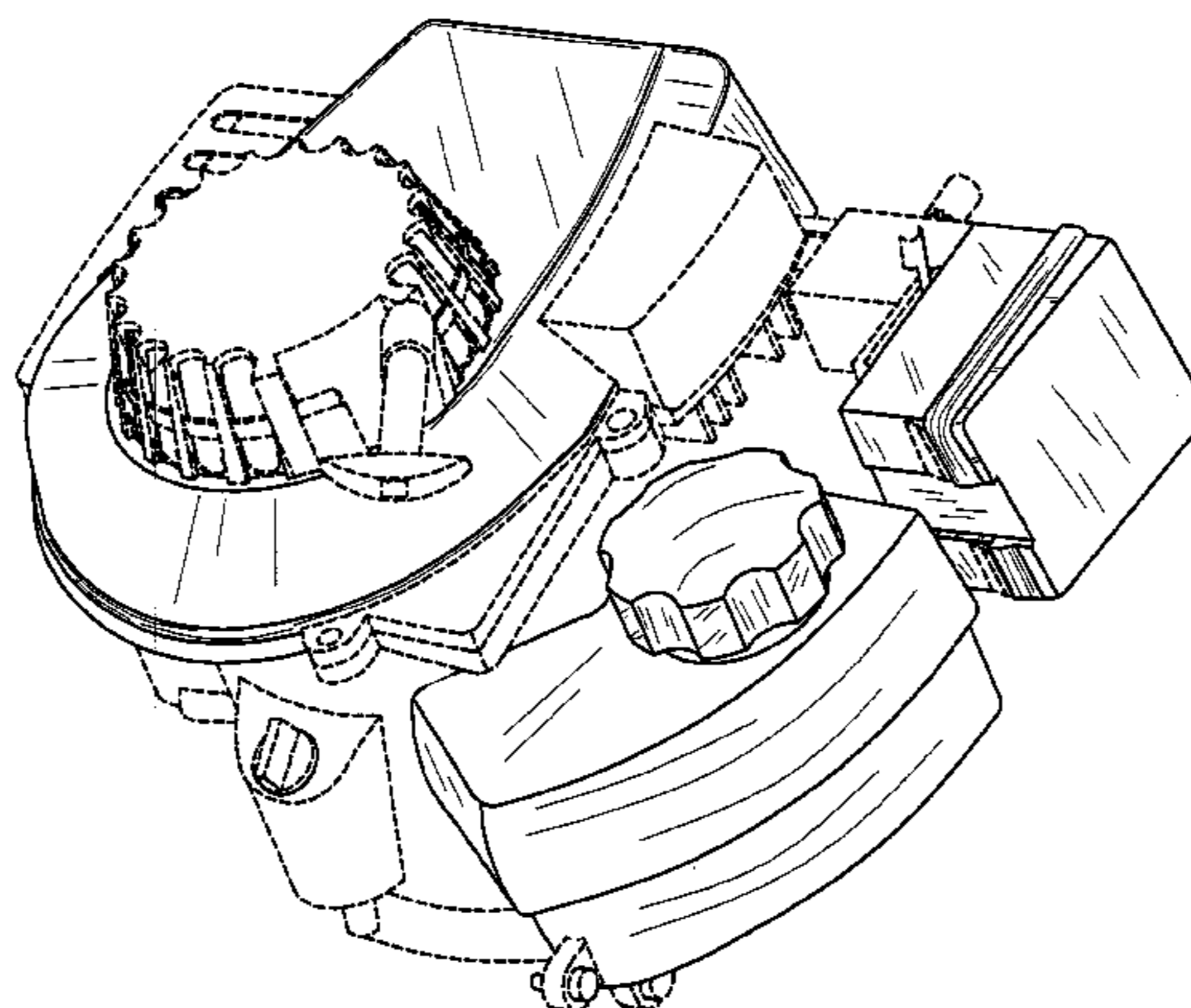

OTHER PUBLICATIONS

KAWASAKI, Four-Cycle Engines, Kawasaki FH500V, website, http://www.kawpowr.com/4cycle/fh500v_specs.html, 1 page, Feb. 2, 2005.

KAWASAKI, Four-Cycle Engines, Kawasaki FC150V, website, http://www.kawpowr.com/4cycle/fc150v_specs.html, 1 page, Feb. 2, 2005.

KAWASAKI, Four-Cycle Engines, Kawasaki FH721V, website, http://www.kawpowr.com/4cycle/fh721v_specs.html, 1 page, Feb. 2, 2005.

Tecumseh Power Company; Walk-Behind Engines & Transmissions Horsepower Range: 3.5-7.0, website <http://www.tecumsehpower.com/Products/WalkBehind/index.php>, 1 page, Feb. 2, 2005.

Kohler Co. Engine Division; Kohler Engines Born to Run Owner's Manual, Command 11-16 HP Vertical Crankshaft; Cover Sheet, Revised Sep. 1999, Kohler Co. Engine Division, Kohler, Wisconsin, USA.

Kohler Co. Engine Division; Kohler Engines Born to Run Owner's Manual, Command 18-26 HP Horizontal Crankshaft; Cover Sheet, Revised May 1999, Kohler Co. Engine Division, Kohler, Wisconsin, USA.

Kohler Co. Engine Division; Kohler Engines Born to Run Owner's Manual, Command 11-15 HP Horizontal Crankshaft; Cover Sheet, Revised Apr. 1999, Kohler Co. Engine Division, Kohler, Wisconsin, USA.

Kohler Co. Engine Division; Kohler Engines Born to Run Owner's Manual, Magnum 8,12,16 HP Horizontal Crankshaft; Cover Sheet, Revised Dec. 2001, Kohler Co. Engine Division, Kohler, Wisconsin, USA.

Kohler Co. Engine Division; Kohler Engines Service Manual, Courage Series SV470-600 Vertical Crankshaft; website http://www.kohlerengines.com/onlinecatalog/detail.jsp?prod_num=Hydro+13, Cover Sheet, Feb. 2, 2005, Kohler Co. Engine Division, Kohler, Wisconsin, USA.

Kohler Co. Engine Division; Kohler Engines Kohler Triad OHC; website http://www.kohlerengines.com/onlinecatalog/enginefamily.jsp?engine_family_name=Triad+OHC, Cover Sheet Feb. 2, 2005, Kohler Co. Engine Division, Kohler, Wisconsin, USA.

Honda Engines, Honda GC Series Engines, brochure, 2003, 10 pages, American Honda Motor Co, Inc.

* cited by examiner

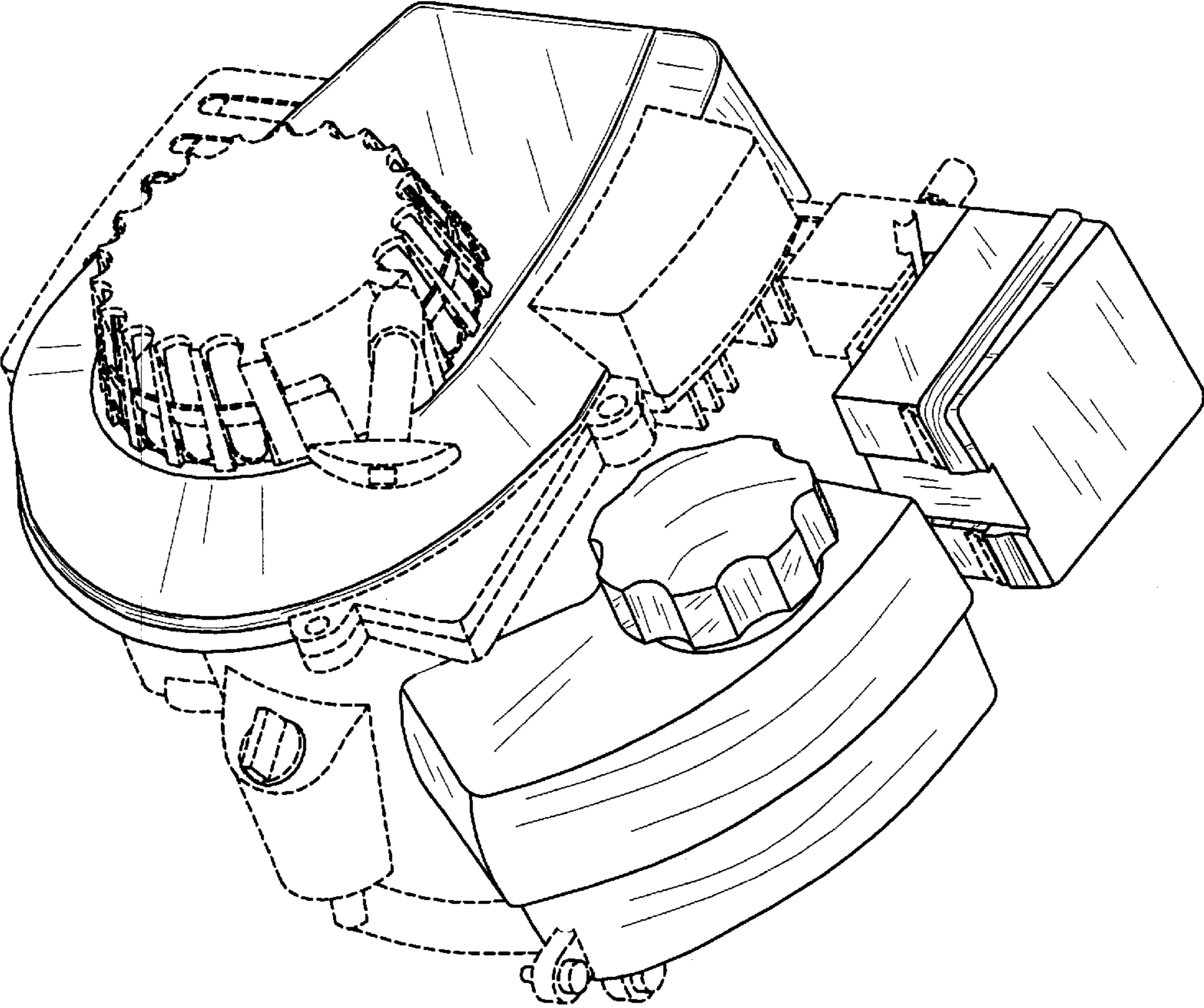

FIG. 1

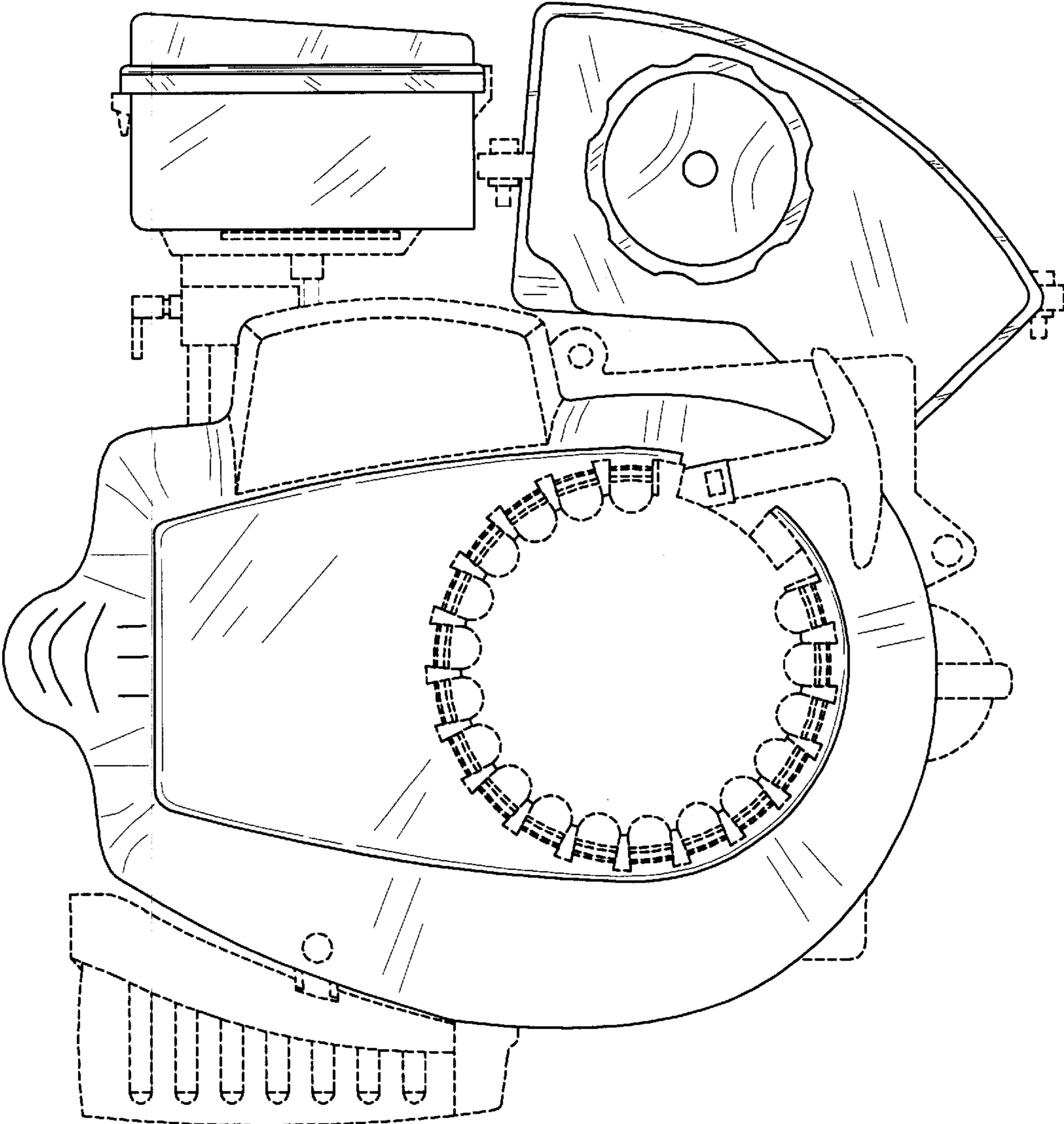

FIG. 2

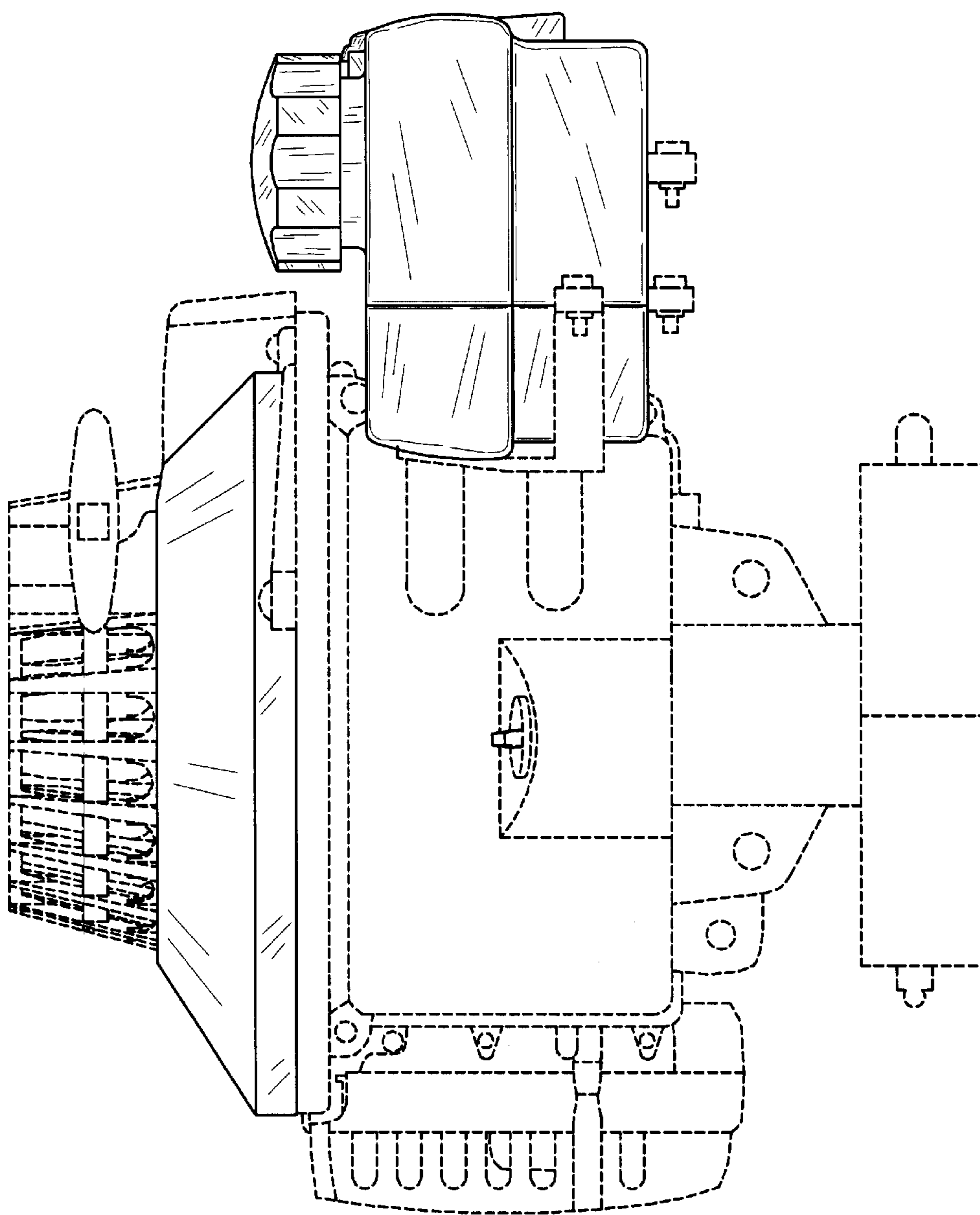

FIG. 3

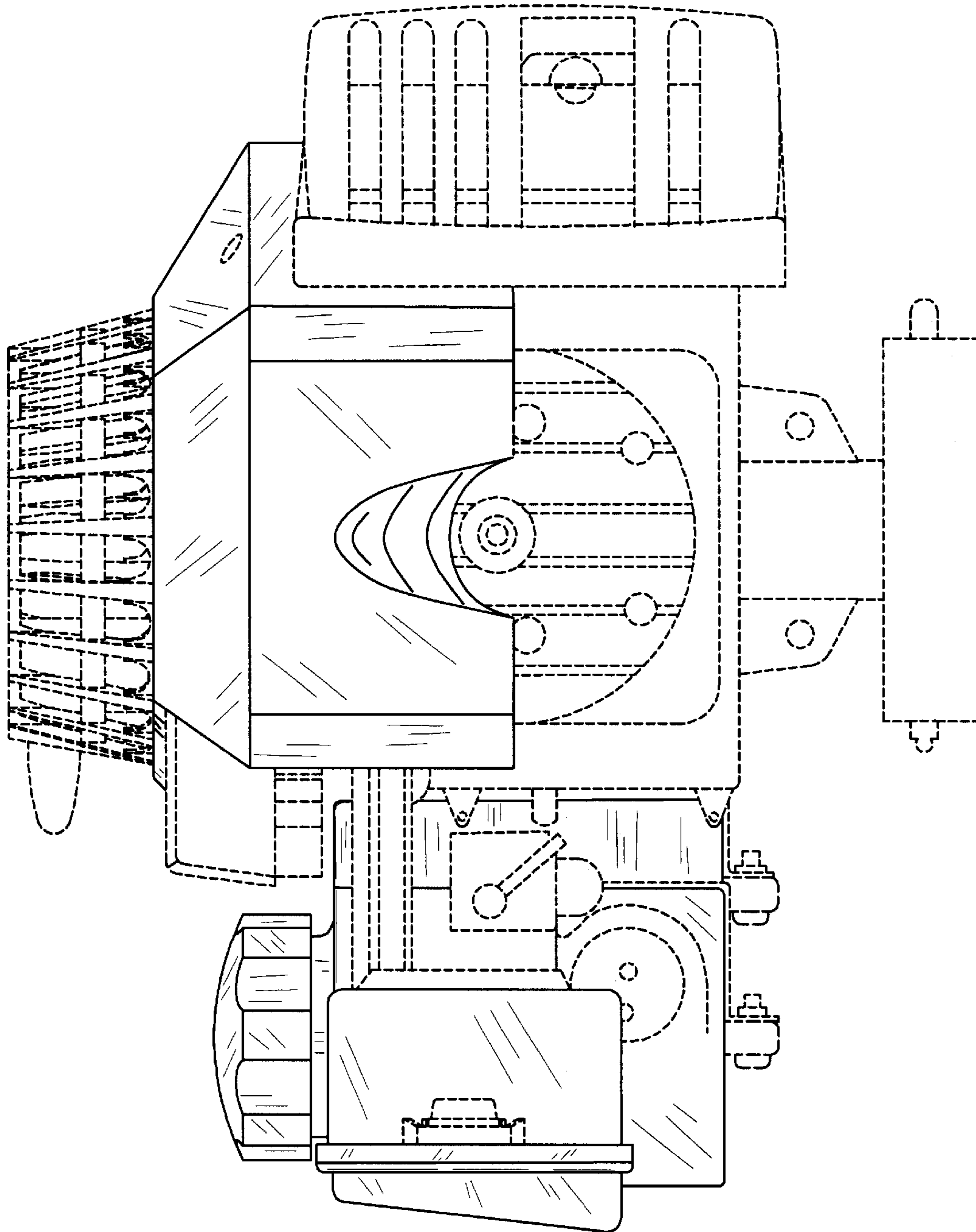

FIG. 4

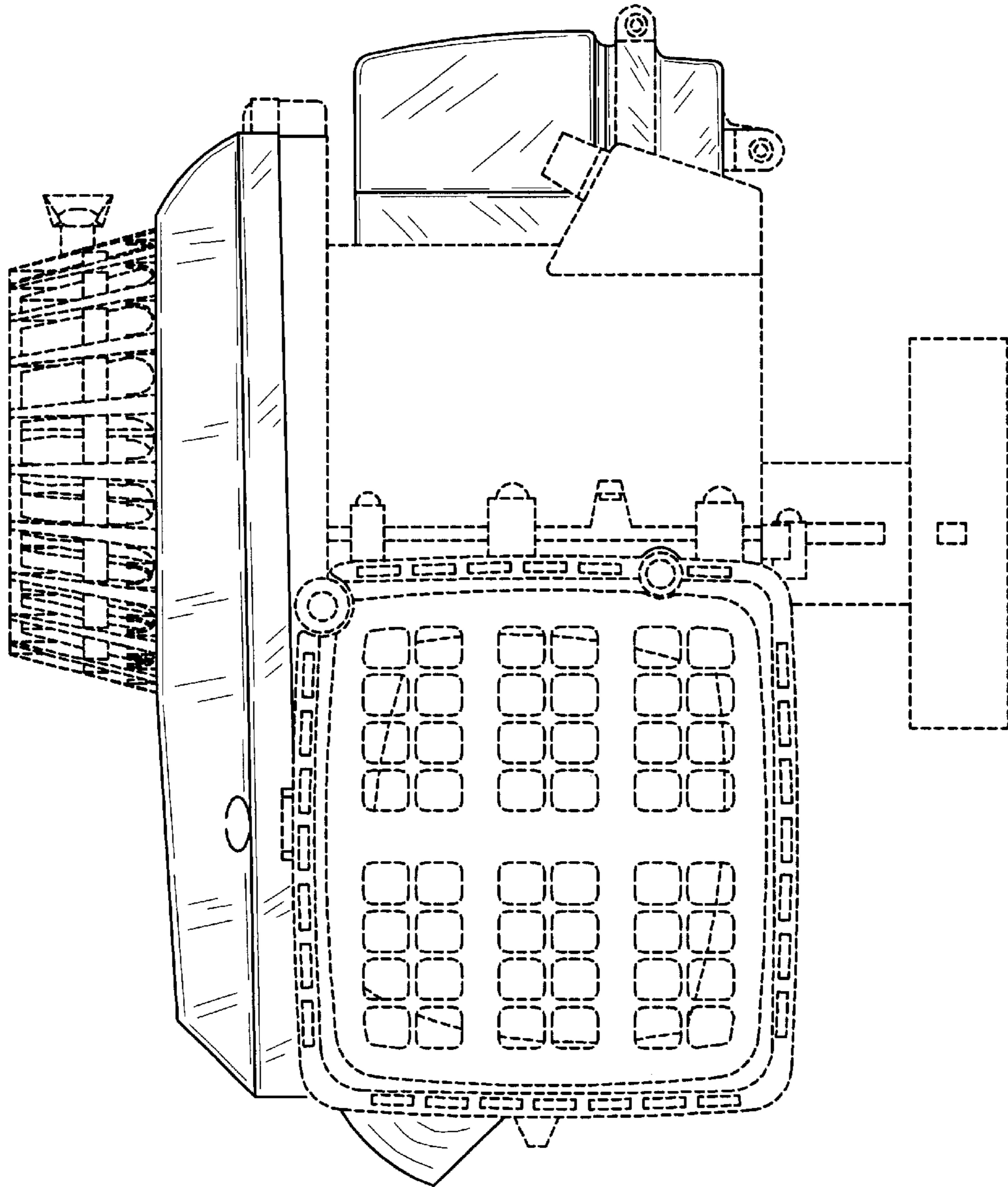

FIG. 5

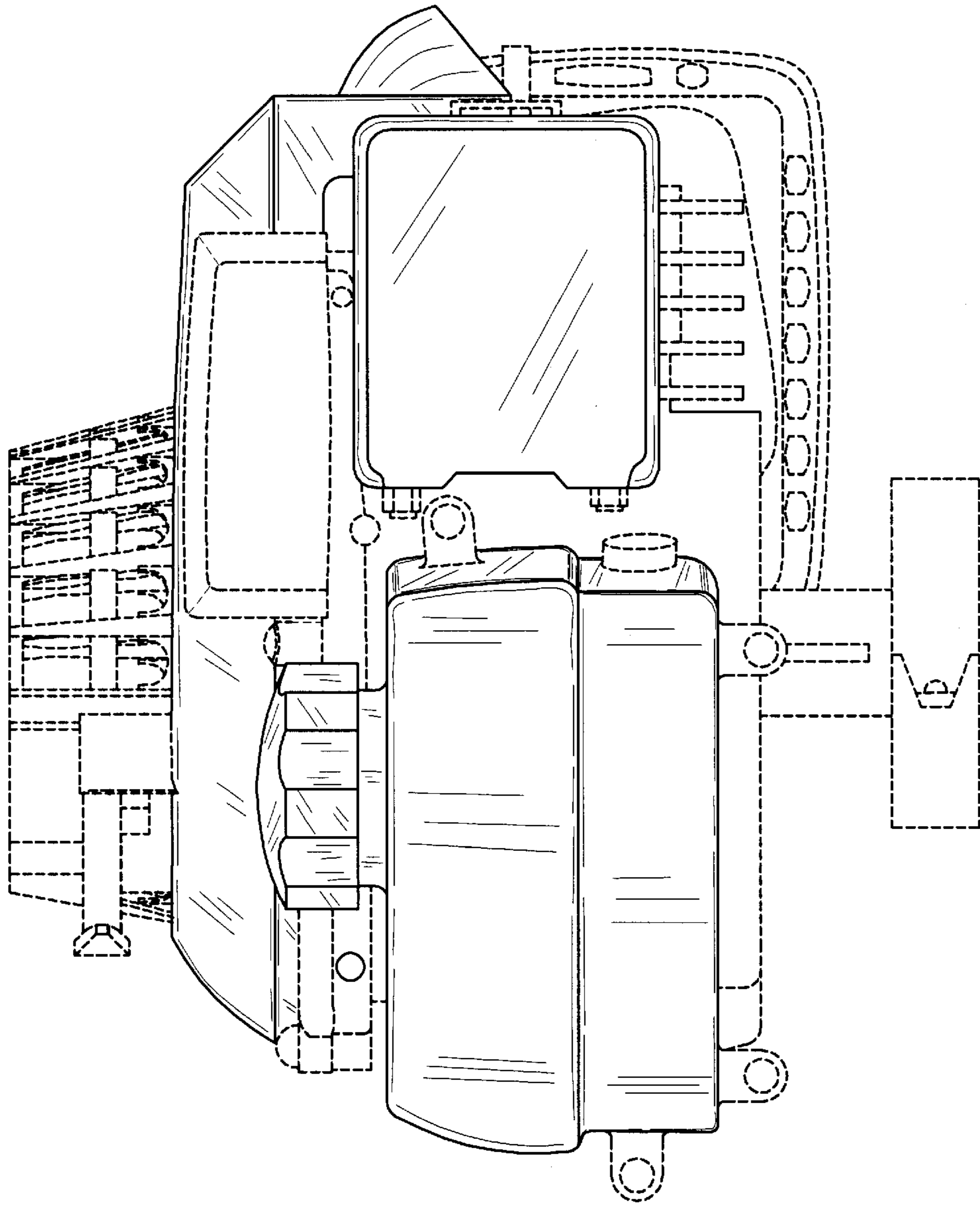

FIG. 6

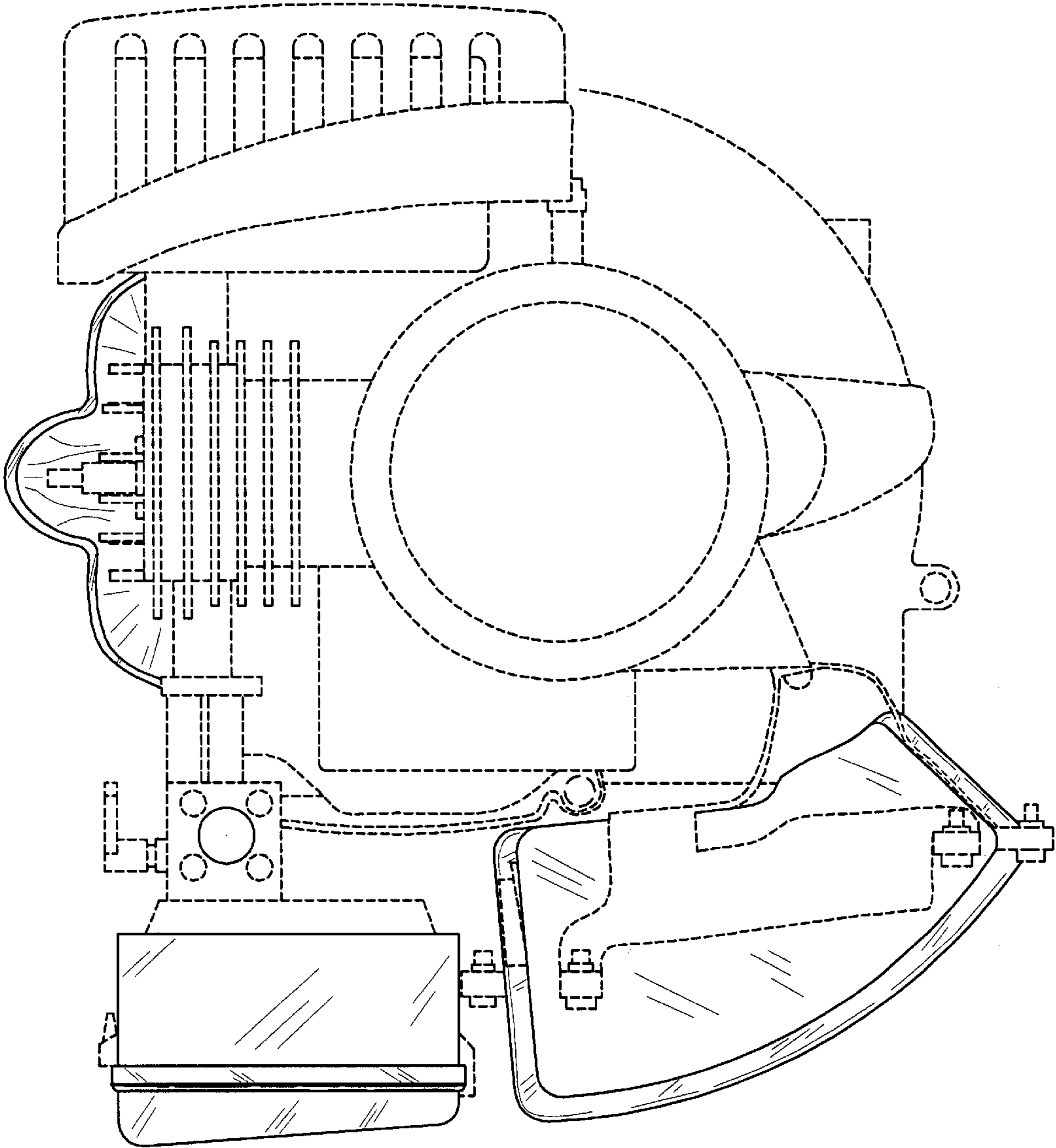

FIG. 7