

US00D528045S

(12) **United States Design Patent**  
**Yin et al.**

(10) **Patent No.:** **US D528,045 S**

(45) **Date of Patent:** **\*\* Sep. 12, 2006**

(54) **MOTORCYCLE**

(75) Inventors: **Mingshan Yin**, Chongqing (CN);  
**Yunfeng Liang**, Chongqing (CN)

(73) Assignee: **Chongqing Lifan Industry (Group) Co., Ltd.** (CN)

(\*\*) Term: **14 Years**

(21) Appl. No.: **29/225,058**

(22) Filed: **Mar. 11, 2005**

(30) **Foreign Application Priority Data**

Sep. 13, 2004 (CN) ..... 2004300526052

(51) **LOC (8) Cl.** ..... **12-11**

(52) **U.S. Cl.** ..... **D12/110**

(58) **Field of Classification Search** ..... D12/110;  
180/219, 220, 225, 229

See application file for complete search history.

(56) **References Cited**

**PUBLICATIONS**

2003 Victory Kingpin. [Retrieved on Sep. 7, 2005].  
Retrieved from the Internet <URL:http://cgi.ebay.com/ebay-

motors/VICTORY-KINGPIN-03-WITH 3500MILES-  
LIKE-NEW\_>.\*

\* cited by examiner

*Primary Examiner*—Alan P. Douglas

*Assistant Examiner*—Linda Brooks

(74) *Attorney, Agent, or Firm*—Crowell & Moring LLP

(57) **CLAIM**

The ornamental design for a motorcycle, as shown and described.

**DESCRIPTION**

FIG. 1 is a perspective view of a motorcycle according to my novel design;

FIG. 2 is a left side view thereof;

FIG. 3 is a right side view thereof;

FIG. 4 is a front view thereof;

FIG. 5 is a rear view thereof; and,

FIG. 6 is a top view thereof.

The broken lines shown are for illustrative purposes only and form no part of the claimed design.

**1 Claim, 5 Drawing Sheets**

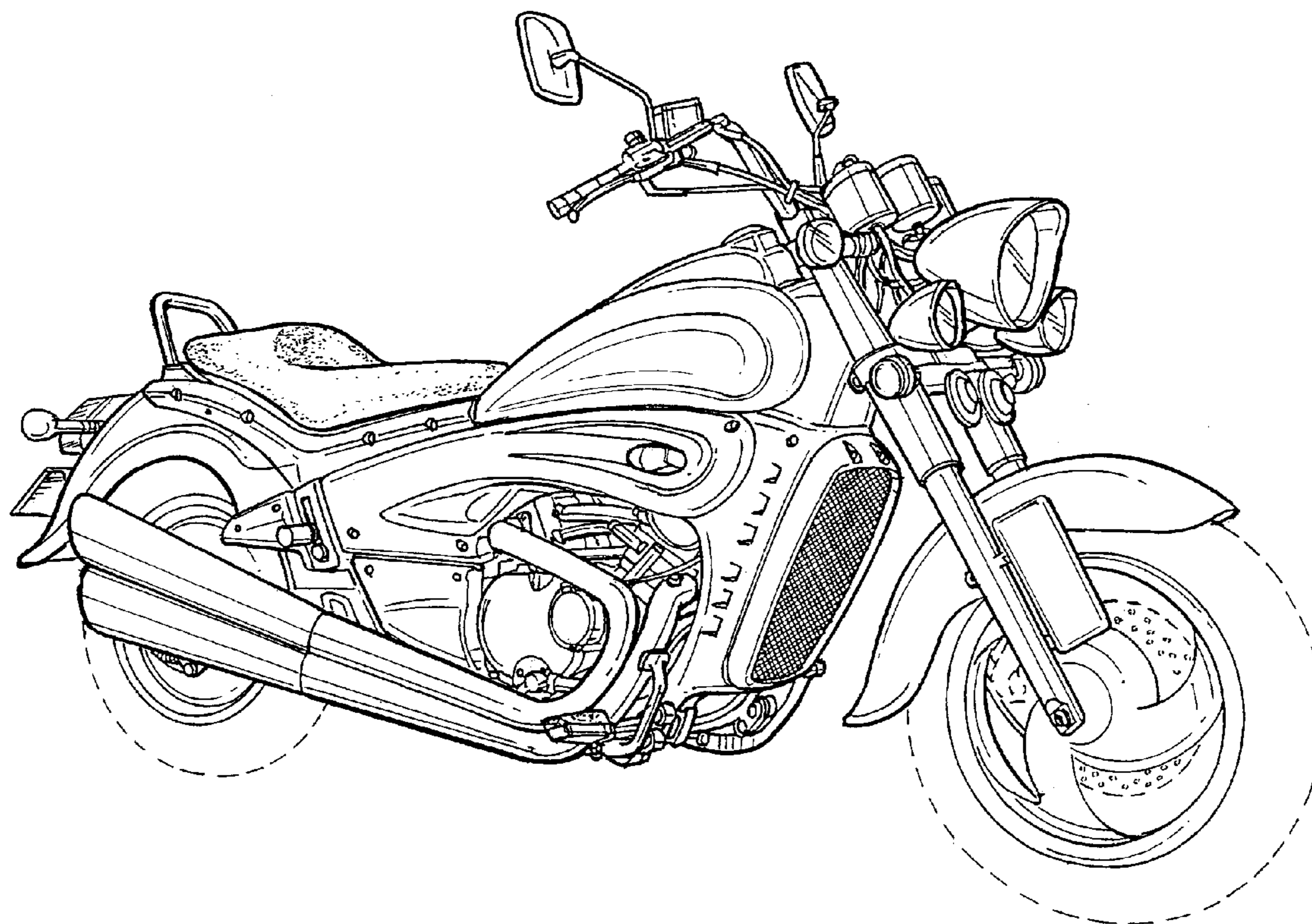

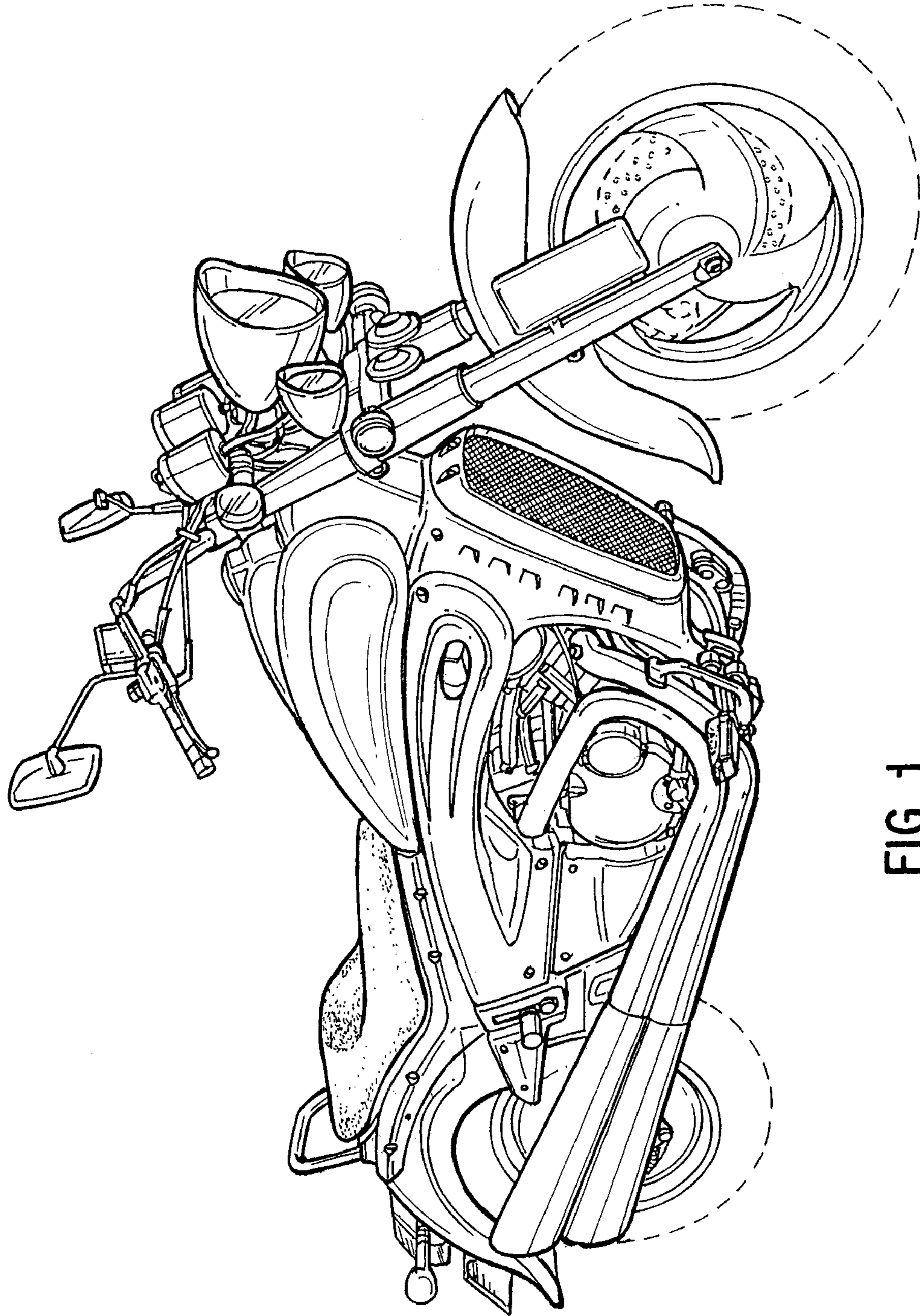

FIG. 1

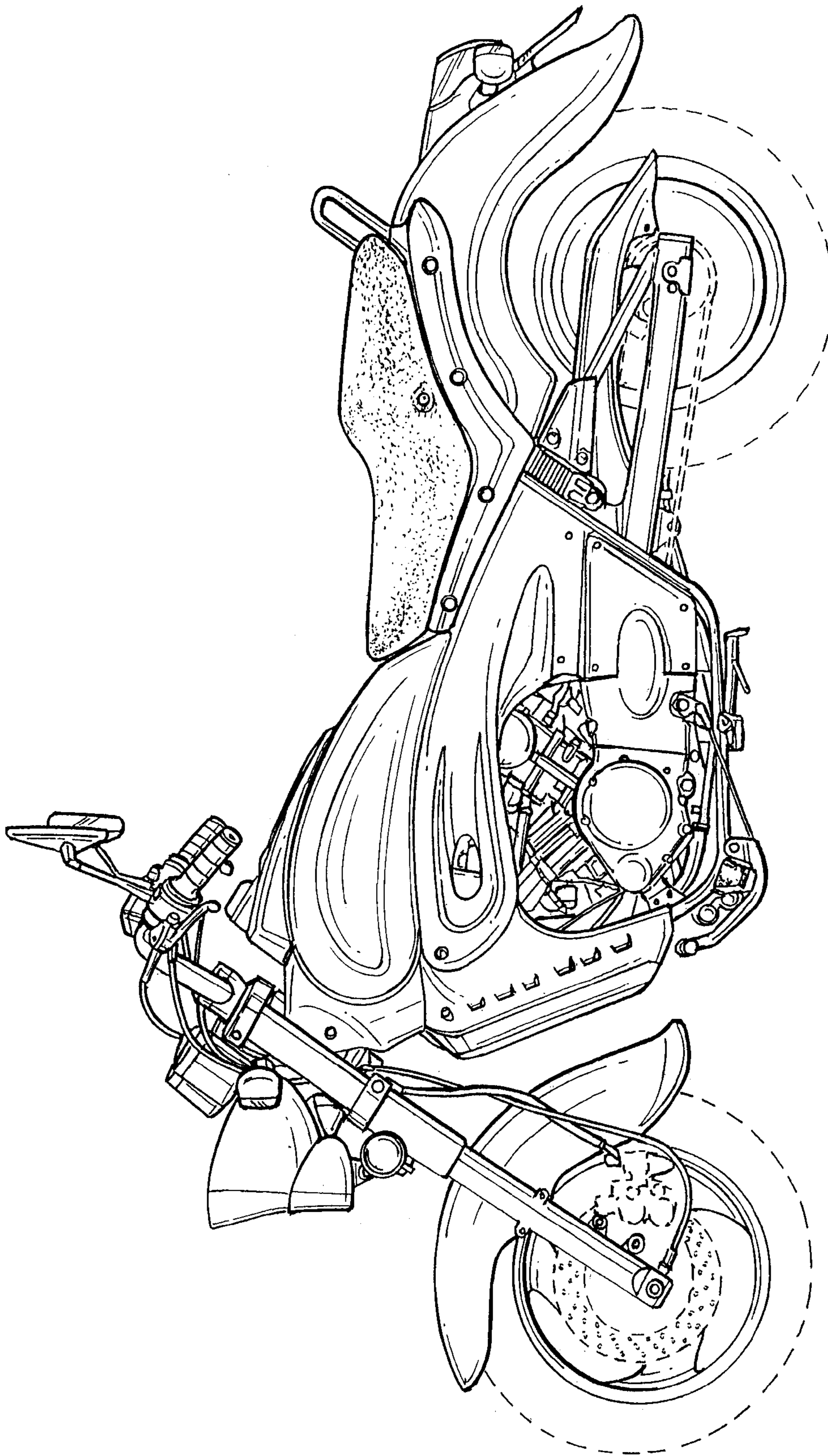

FIG. 2

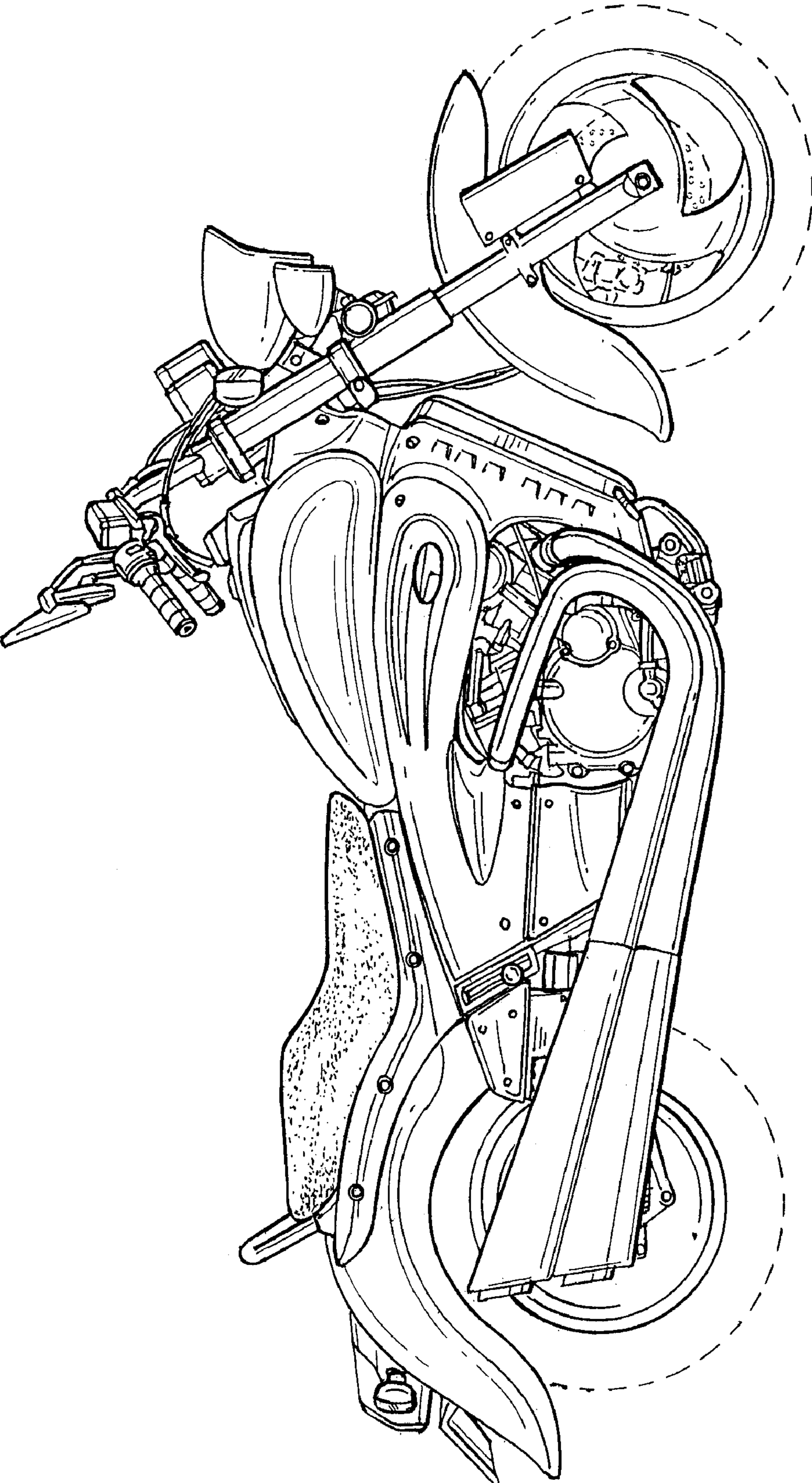

FIG. 3

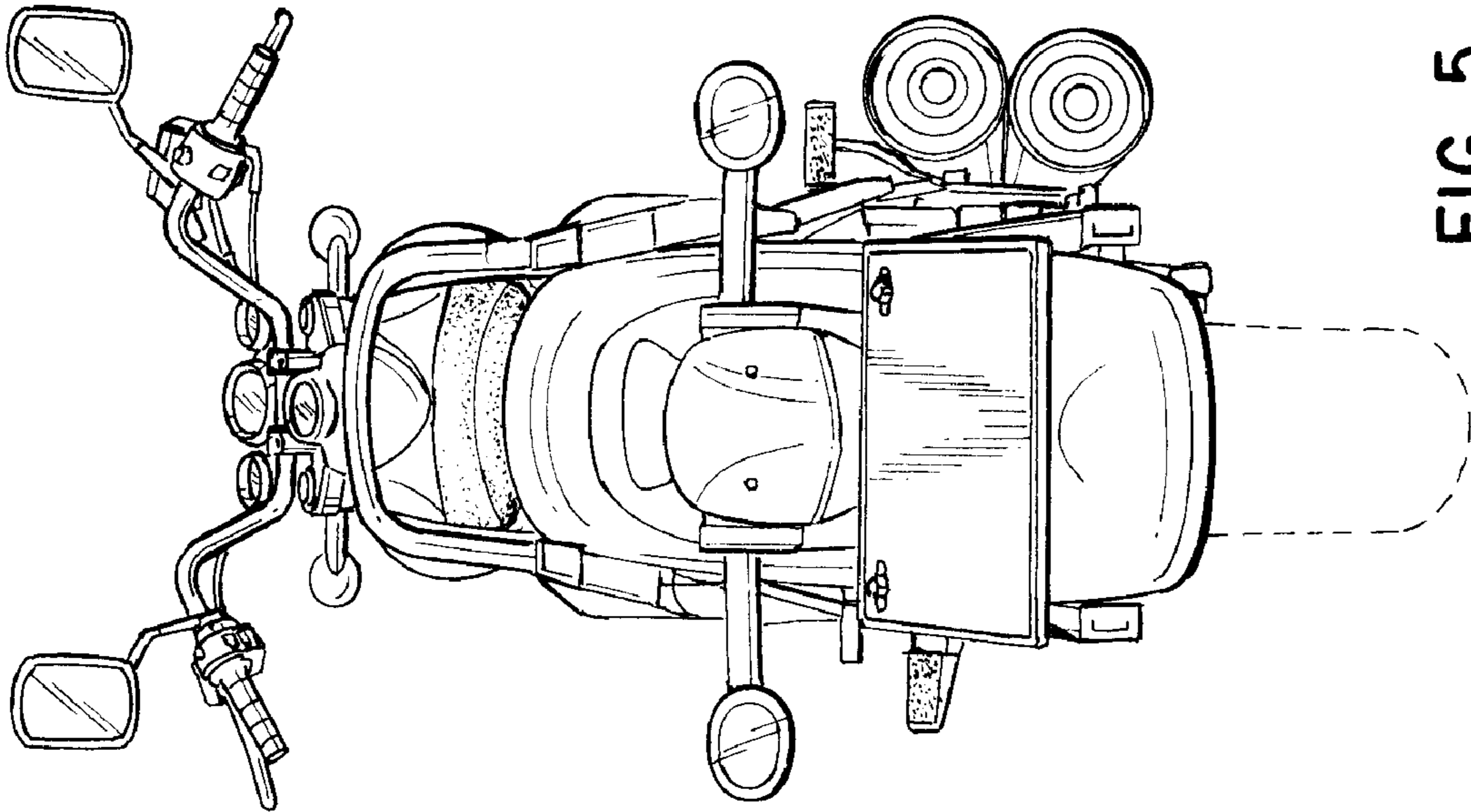

FIG. 5

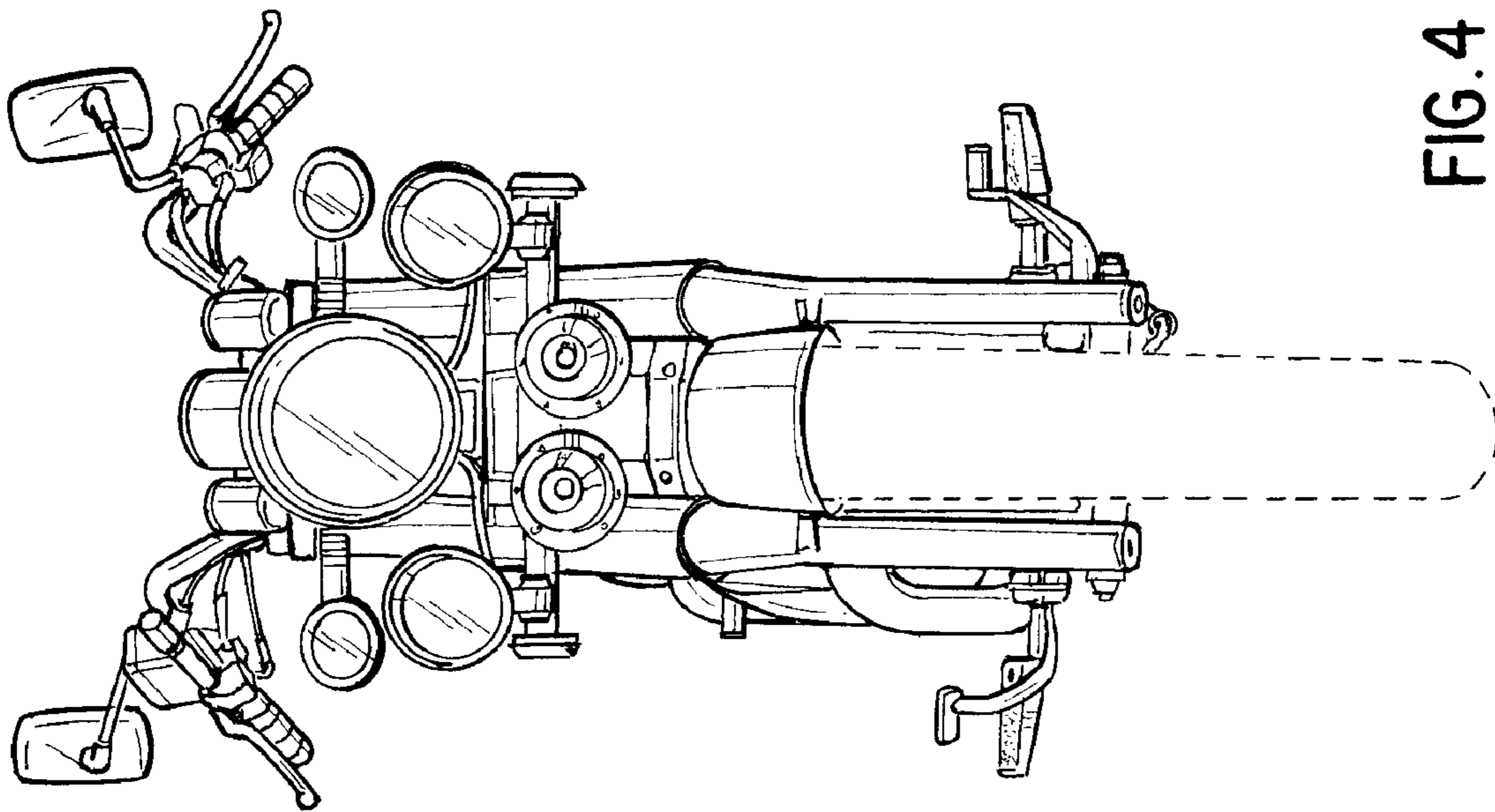

FIG. 4

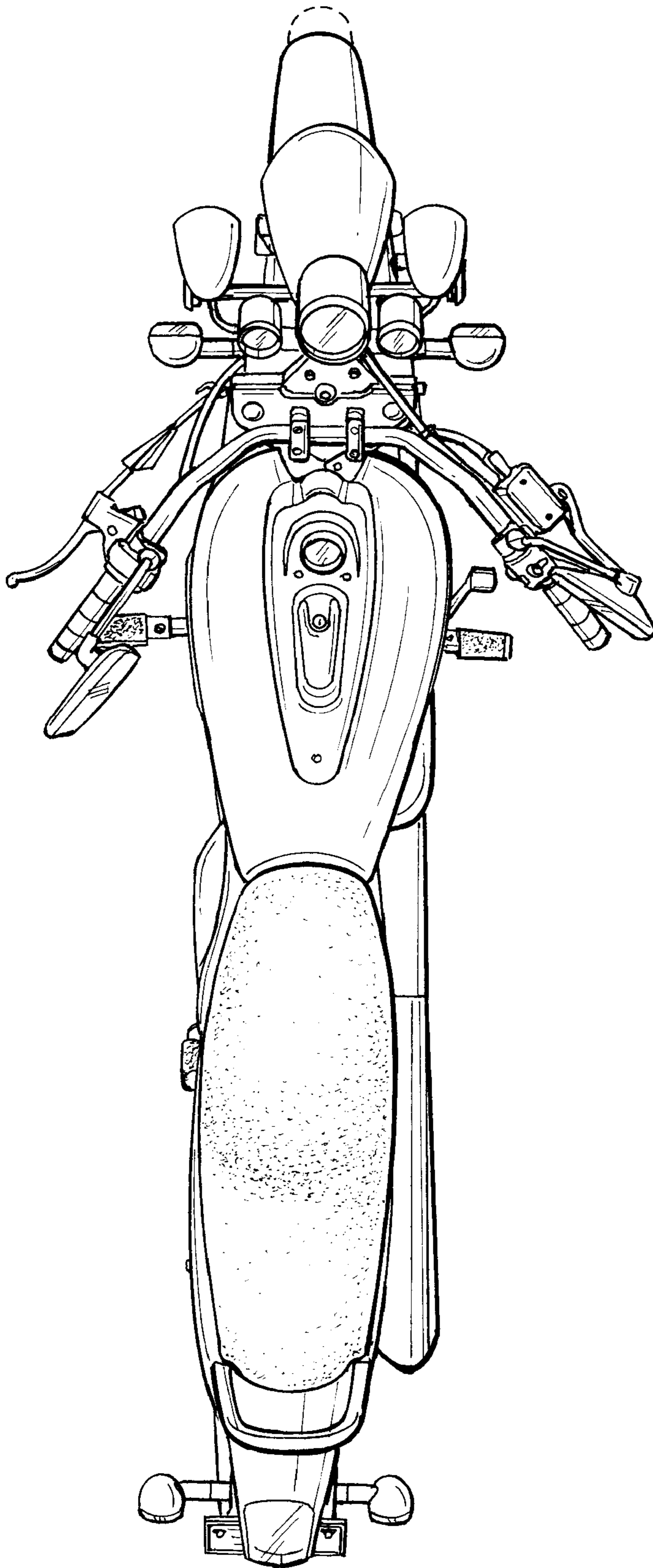

FIG. 6