

US00D527400S

(12) **United States Design Patent** (10) **Patent No.:** **US D527,400 S**
Konet (45) **Date of Patent:** **** Aug. 29, 2006**

(54) **CUTTING INSERT**

(75) Inventor: **Keith Konet**, Copley, OH (US)
(73) Assignee: **Manchester Tool Company**, Akron, OH (US)
(**) Term: **14 Years**

(21) Appl. No.: **29/220,319**
(22) Filed: **Dec. 29, 2004**

(51) **LOC (8) Cl.** **15-09**
(52) **U.S. Cl.** **D15/139**
(58) **Field of Classification Search** D15/138,
D15/139; 407/35, 42, 112-119
See application file for complete search history.

(56) **References Cited**

U.S. PATENT DOCUMENTS

4,340,325	A	7/1982	Gowanlock	
D275,760	S	10/1984	Cochran	
4,558,974	A	12/1985	Pano	
4,629,372	A	12/1986	Huston	
4,778,311	A	10/1988	Niemi	
4,801,224	A	1/1989	Pettersson et al.	
4,832,541	A	5/1989	Noguchi et al.	
D306,032	S	* 2/1990	Mihic	D15/139
4,973,204	A	11/1990	Mihic	
4,992,008	A	2/1991	Pano	
5,040,930	A	8/1991	Zinner	
5,085,541	A	2/1992	Simpson, III	
5,135,336	A	8/1992	Noguchi et al.	
5,137,396	A	8/1992	Durschinger	
D329,439	S	9/1992	Gustafsson et al.	
D329,858	S	* 9/1992	Gustafsson et al.	D15/139
5,161,920	A	11/1992	Zinner	
D338,477	S	* 8/1993	Mihic	D15/139
D343,400	S	* 1/1994	Lindstedt et al.	D15/139
5,315,908	A	5/1994	Mihic	
D350,549	S	9/1994	Lindstedt et al.	

(Continued)

OTHER PUBLICATIONS

ISCAR (Member IMC Group), Heliface Face Machining, Iscar Turn Plus Catalog, Oct. 2001, p. G51, United States of America.
ISCAR (Member IMC Group), Self-Grip Slitting Cutters, Iscar Turn Plus Catalog, Oct. 2001, p. F8, United States of America.
Sandvik Coromant, T-Max Q-Cut inserts (Parting and Grooving), Sandvik Turning Tools And Inserts Catalog, Mar. 2000, p. B17, Sweden.
Sandvik Coromant, T-Max Q-Cut inserts geometries and grades (Parting and Grooving), Sandvik Turning Tools And Inserts Catalog, Mar. 2000, p. B7, Sweden.

Primary Examiner—Antoine D. Davis
Assistant Examiner—Patricia Palasik
(74) *Attorney, Agent, or Firm*—Watts Hoffmann Co., L.P.A.

(57) **CLAIM**

I claim the ornamental design for a cutting insert, as shown and described.

DESCRIPTION

FIG. 1 is a perspective view of a cutting insert showing my new design;
FIG. 2 is a side elevational view of the cutting insert shown in FIG. 1;
FIG. 3 is a top plan view of the cutting insert shown in FIG. 1;
FIG. 4 is a bottom plan view of the cutting insert shown in FIG. 1.
FIG. 5 is a left end view of the cutting insert shown in FIG. 1; and,
FIG. 6 is a right end view of the cutting insert shown in FIG. 1.
The broken lines in FIGS. 1-6 are for illustrative purposes only and do not form part of the invention shown in FIGS. 1-6.

1 Claim, 2 Drawing Sheets

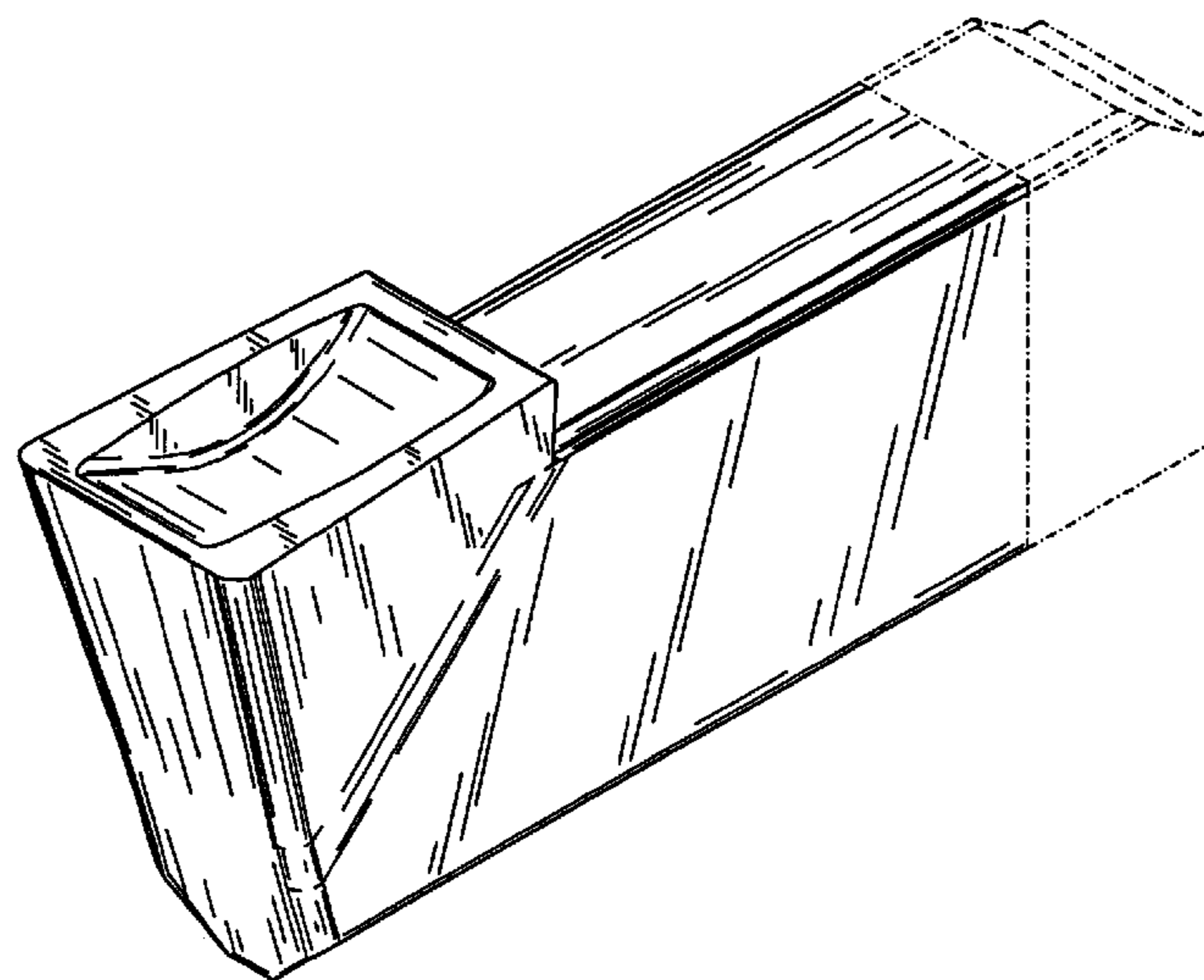

US D527,400 S

Page 2

U.S. PATENT DOCUMENTS					
			5,975,812 A	11/1999	Friedman
			5,993,118 A	11/1999	Brask et al.
5,360,298 A	11/1994	Hedlund	6,086,291 A	7/2000	Hansson et al.
5,375,948 A	12/1994	Lindstedt	6,146,064 A	11/2000	Flolo
5,382,119 A	1/1995	Mihic	6,238,147 B1	5/2001	Tagtstrom et al.
5,423,639 A	6/1995	Wiman	RE37,595 E	3/2002	Lindstedt
5,511,911 A	4/1996	Katbi et al.	6,428,247 B1	8/2002	Friedman
5,676,495 A	10/1997	Katbi et al.	D470,516 S	2/2003	Andersson
5,704,737 A	1/1998	Alford	D470,517 S	2/2003	Andersson
5,725,334 A	* 3/1998	Paya 407/117	6,843,620 B1	1/2005	Inayama
5,827,017 A	10/1998	Tagtstrom et al.	2002/0197119 A1	12/2002	Kinukawa
5,829,924 A	11/1998	Oshnock et al.			
5,921,724 A	7/1999	Erickson et al.			

* cited by examiner

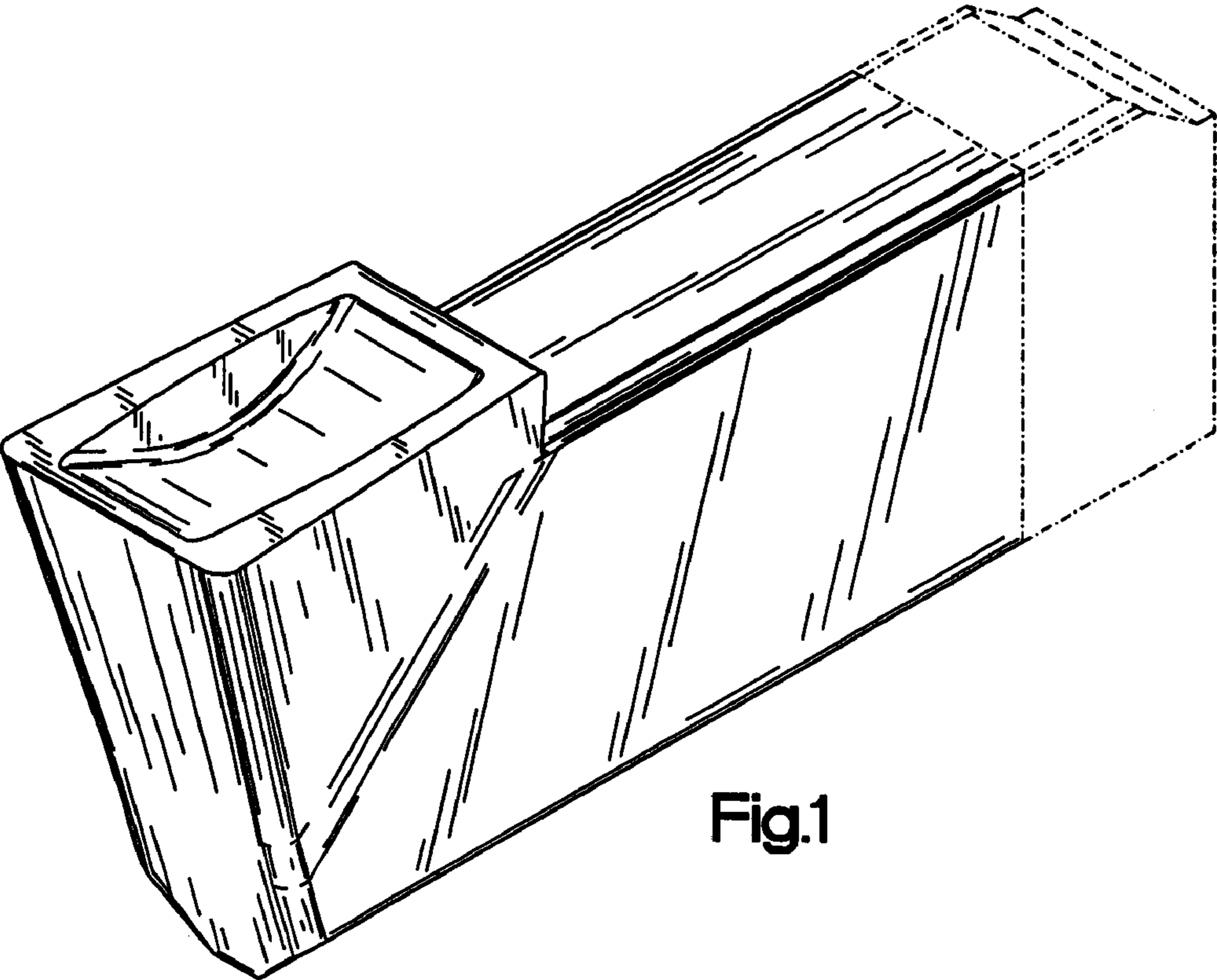

Fig.1

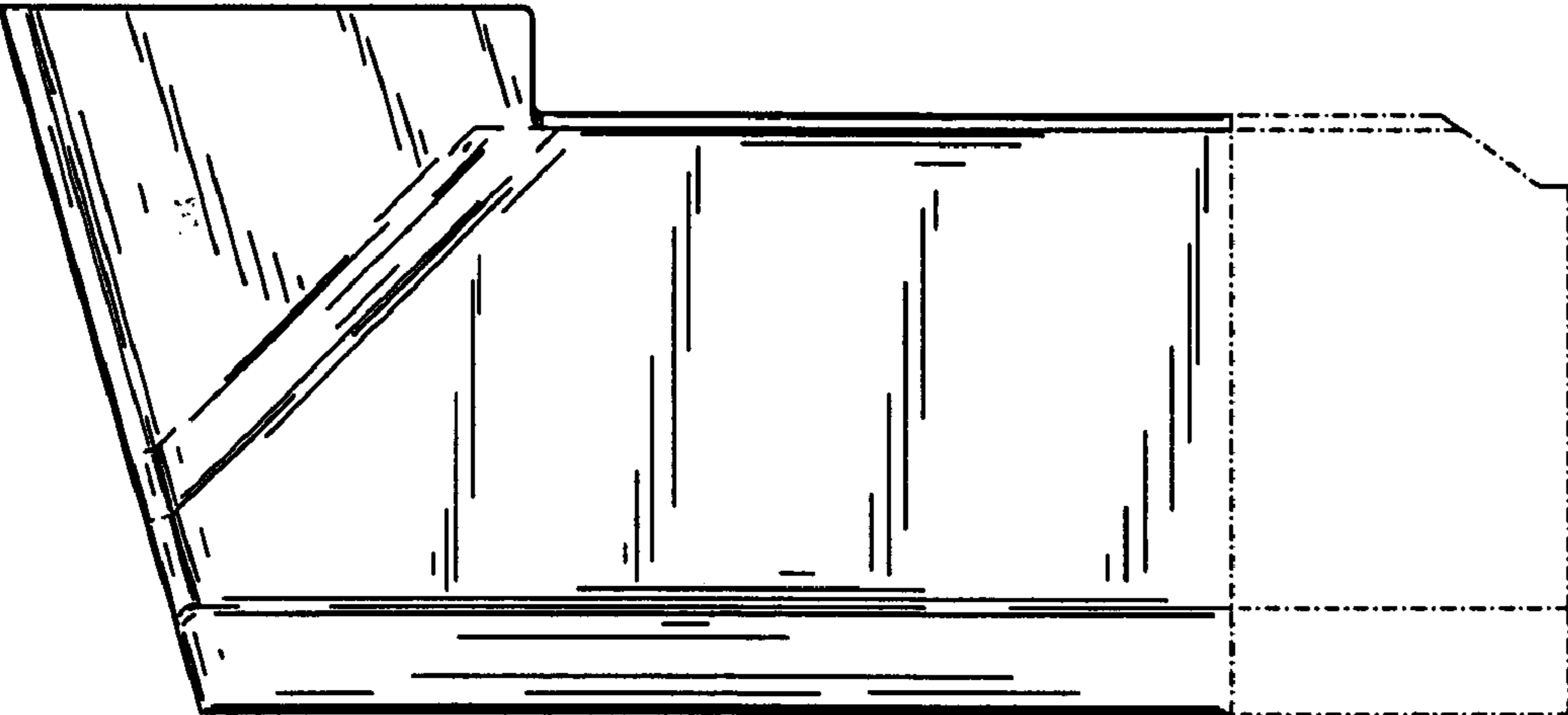

Fig.2

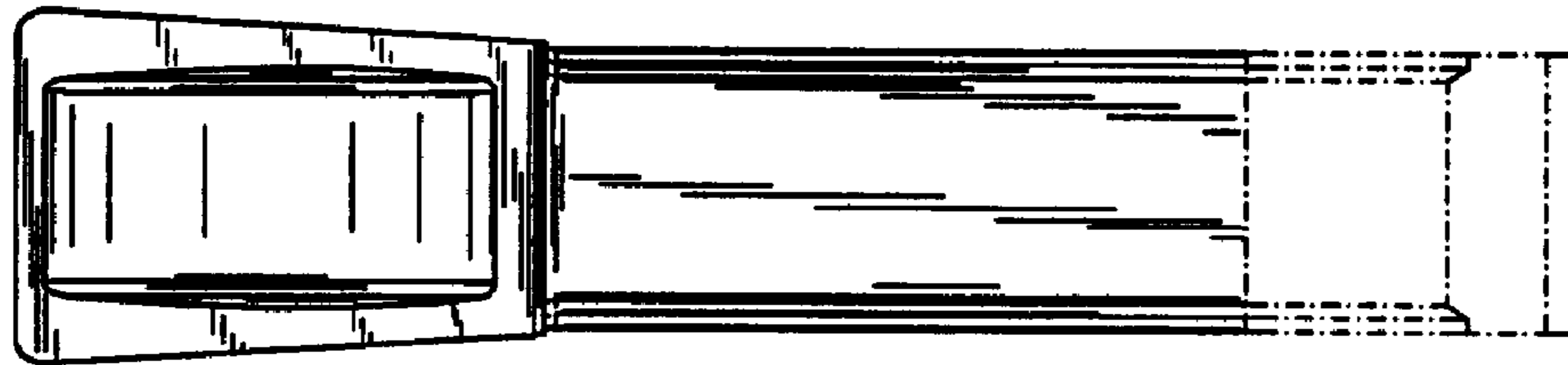

Fig.3

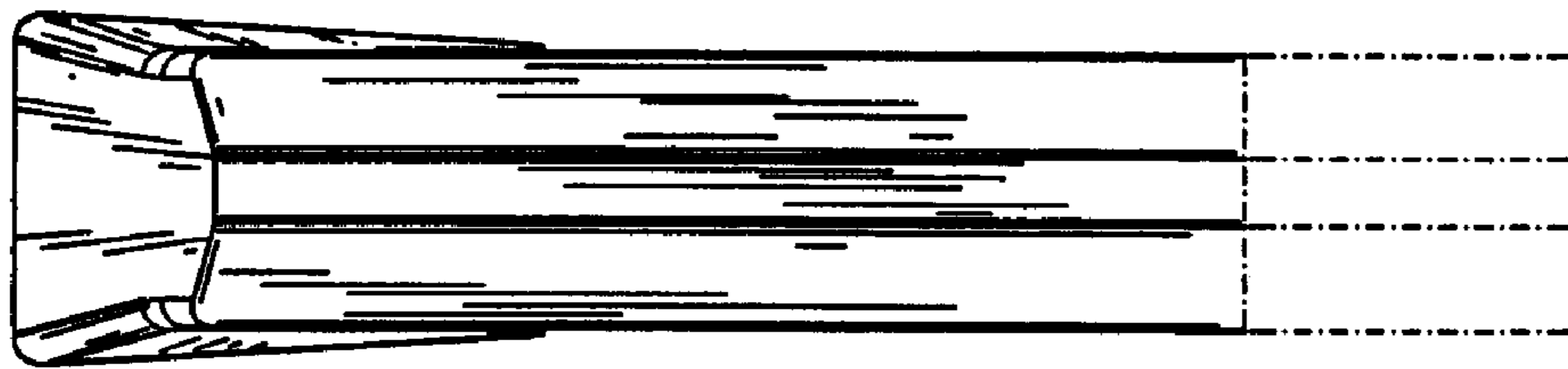

Fig.4

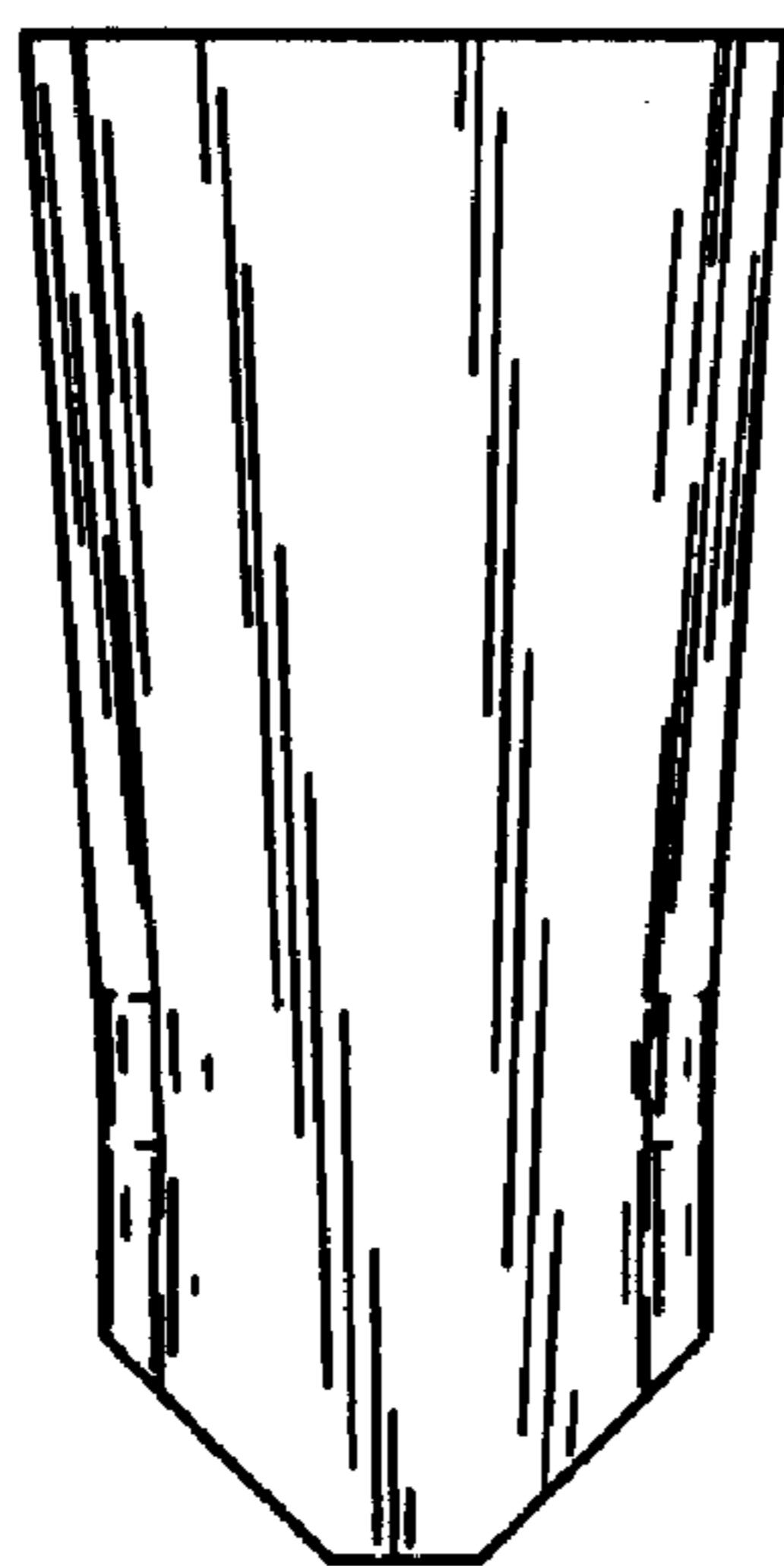

Fig.5

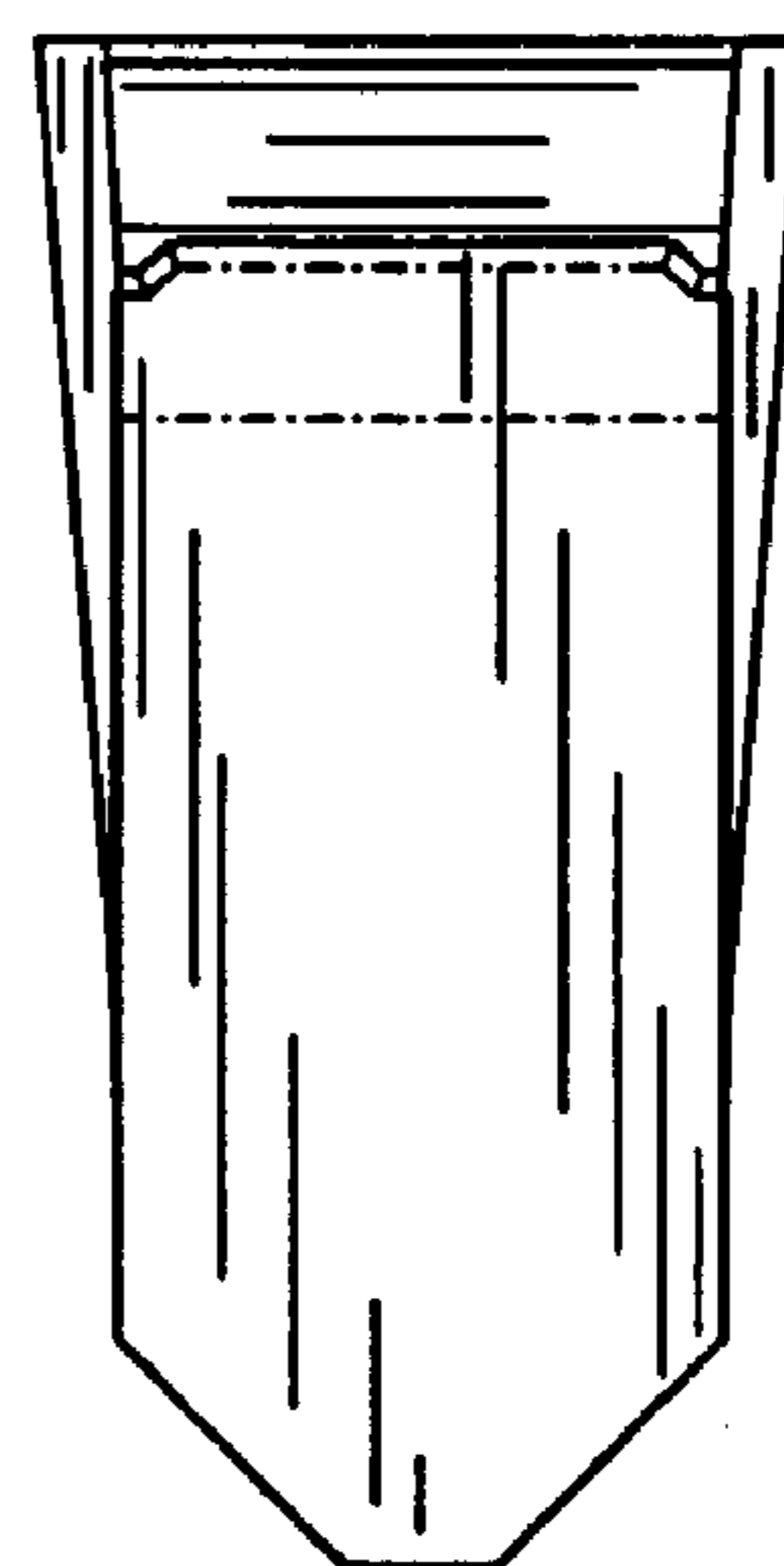

Fig.6