

US00D527237S

(12) **United States Design Patent** (10) **Patent No.:** **US D527,237 S**
Otsuka et al. (45) **Date of Patent:** **** Aug. 29, 2006**

(54) **PORTION OF A PORTABLE ELECTRIC DRIVER**

(75) Inventors: **Hiroshi Otsuka**, Anjo (JP); **Yuji Yamamoto**, Anjo (JP); **Shinsuke Okuda**, Anjo (JP)

(73) Assignee: **Makita Corporation**, Anjo (JP)

(**) Term: **14 Years**

(21) Appl. No.: **29/244,183**

(22) Filed: **Dec. 7, 2005**

Related U.S. Application Data

(62) Division of application No. 29/234,910, filed on Jul. 26, 2005.

(30) **Foreign Application Priority Data**

Jan. 31, 2005 (JP) 2005-002472
Jan. 31, 2005 (JP) 2005-002473

(51) **LOC (8) Cl.** **08-05**

(52) **U.S. Cl.** **D8/68**

(58) **Field of Classification Search** D8/14.1,
D8/61, 62, 63, 64, 65, 66, 67, 68, 69, 70;
81/57.11, 429, 464, 465, 466, 469, 489; 173/13,
173/169, 178, 213, 217, 114, 201, 211; 227/8,
227/114, 120, 130, 136, 142; 408/20, 124,
408/125, 234, 241 R; 451/358; 310/50
See application file for complete search history.

(56) **References Cited**

U.S. PATENT DOCUMENTS

D392,863 S 3/1998 Sugimoto et al.
D424,902 S 5/2000 Gildersleeve et al.
D437,761 S 2/2001 Okumura et al.
D477,205 S 7/2003 Sakai et al.
D484,385 S 12/2003 Sakai et al.
D489,955 S 5/2004 Concari et al.
6,729,415 B1 5/2004 Huang

6,745,883 B1 6/2004 Eto et al.
D493,344 S 7/2004 Watson
D494,435 S 8/2004 Hayakawa et al.
D499,624 S 12/2004 Concari et al.
D499,945 S 12/2004 Sugawara et al.
6,860,342 B1 3/2005 Wu et al.
6,883,621 B1 4/2005 Lin
D508,642 S 8/2005 Kokawa et al.
D512,891 S * 12/2005 Aglassinger D8/68
D514,412 S * 2/2006 Lawrence et al. D8/68
2002/0122707 A1 9/2002 Sakai et al.
2003/0159843 A1 8/2003 Sakai et al.
2005/0022638 A1 2/2005 Milbourne et al.
2005/0121209 A1 6/2005 Shimizu et al.
2005/0155778 A1 7/2005 Ishida et al.
2006/0011367 A1 * 1/2006 Teng et al. 173/217

FOREIGN PATENT DOCUMENTS

JP S 1158194 9/2002

* cited by examiner

Primary Examiner—T. Chase Nelson

(74) *Attorney, Agent, or Firm*—Oliff & Berridge, PLC

(57) **CLAIM**

The ornamental design for a portion of a portable electric driver, as shown and described.

DESCRIPTION

FIG. 1 is a front and left side perspective view of a portion of a portable electric driver showing our new design; FIG. 2 is a front and right side perspective view thereof; FIG. 3 is a front elevation view thereof; FIG. 4 is a rear elevation view thereof; FIG. 5 is a left side elevation view thereof; FIG. 6 is a right side elevation view thereof; FIG. 7 is a top plan view thereof; and, FIG. 8 is a bottom plan view thereof. The broken lines depict unclaimed portions of the portable electric driver for illustrative purposes only, and form no part of the claimed design.

1 Claim, 6 Drawing Sheets

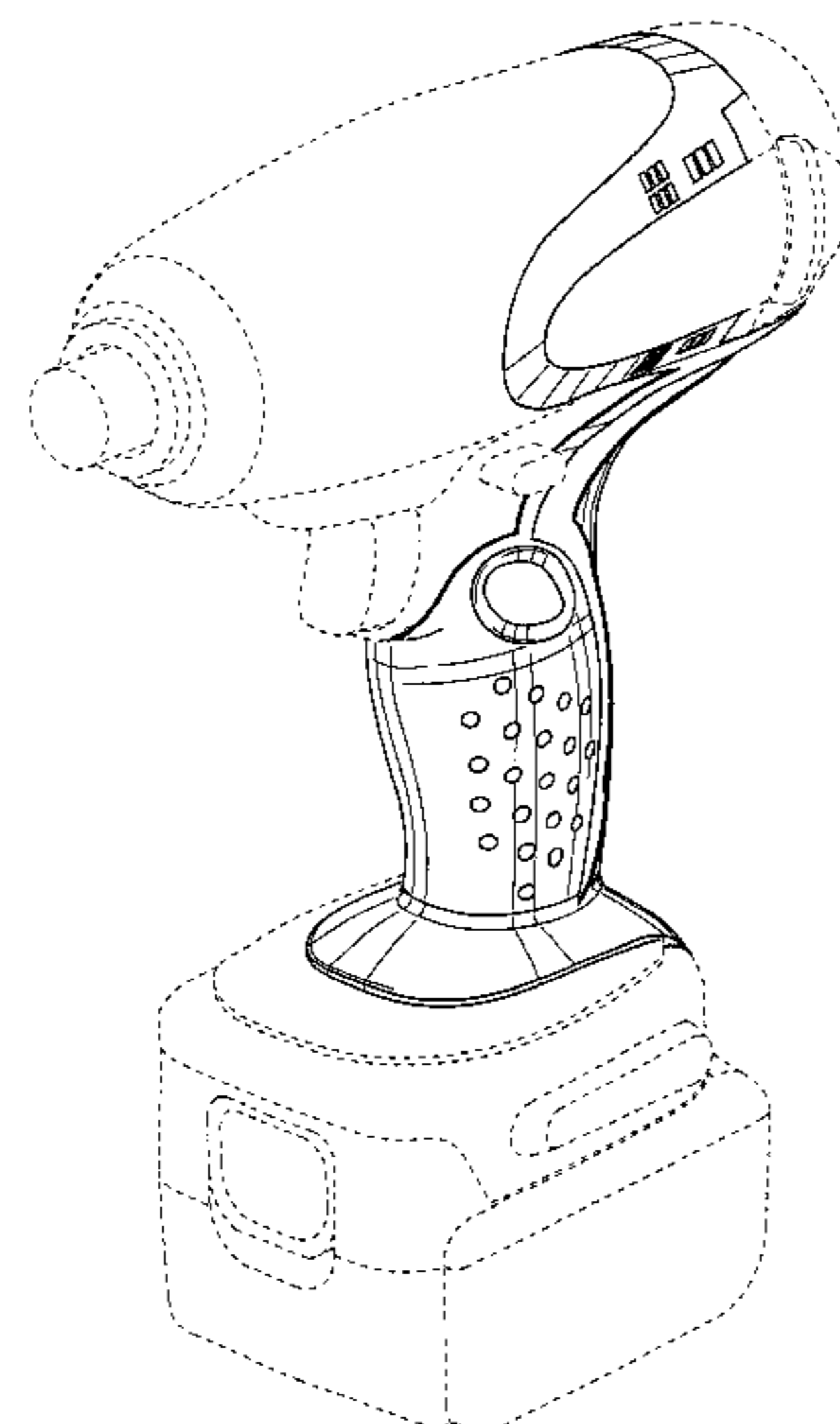

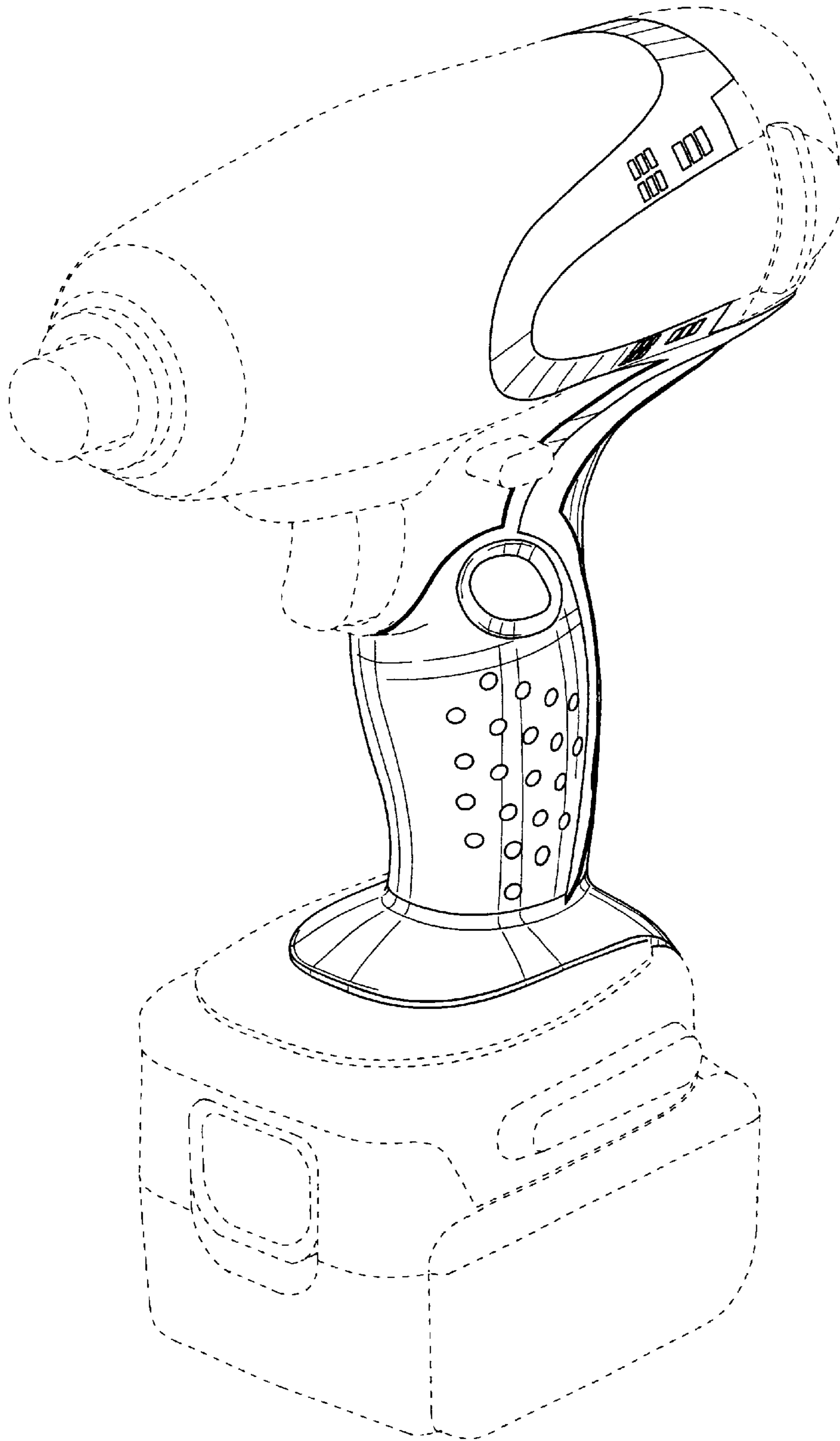

FIG. 1

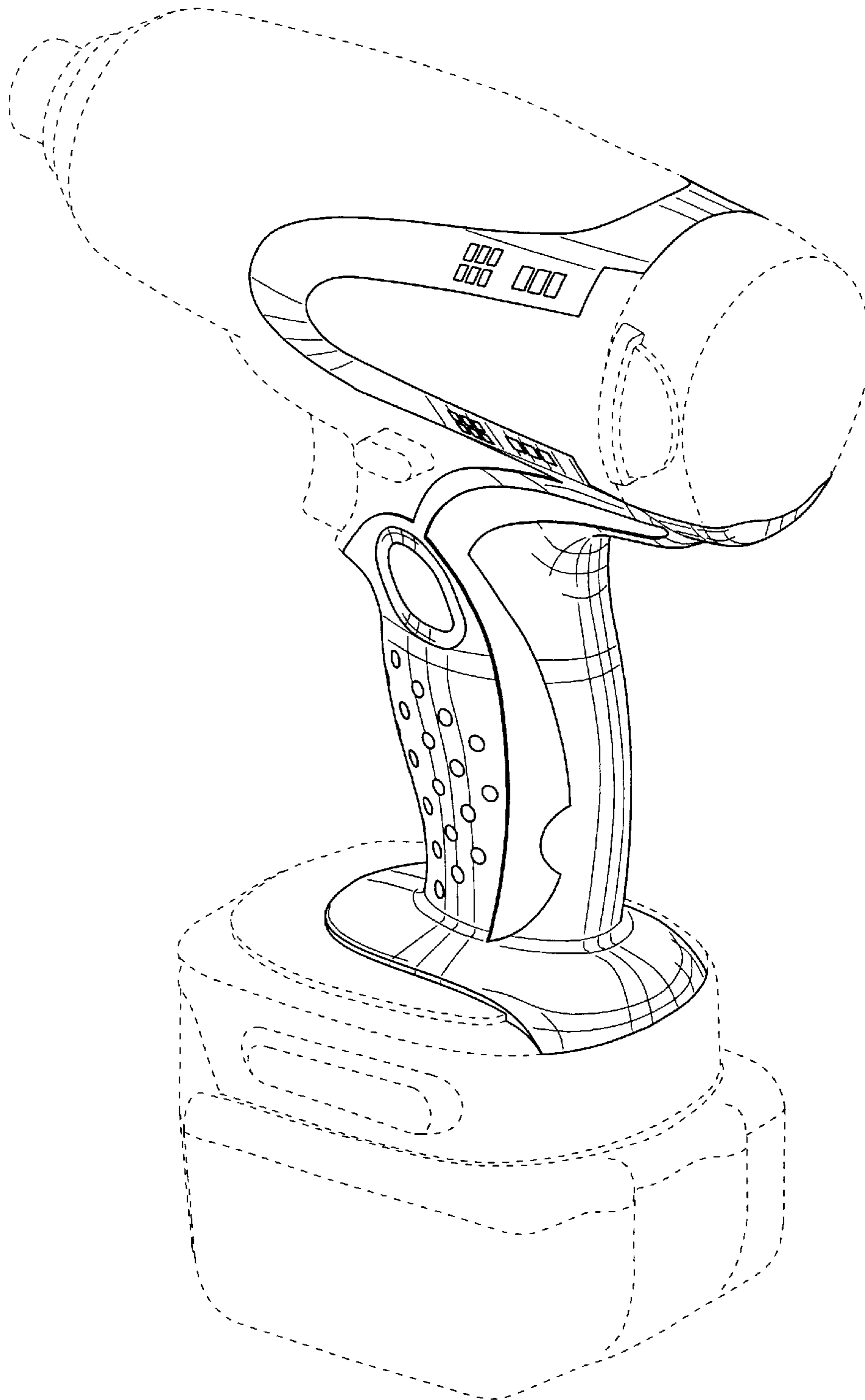

FIG. 2

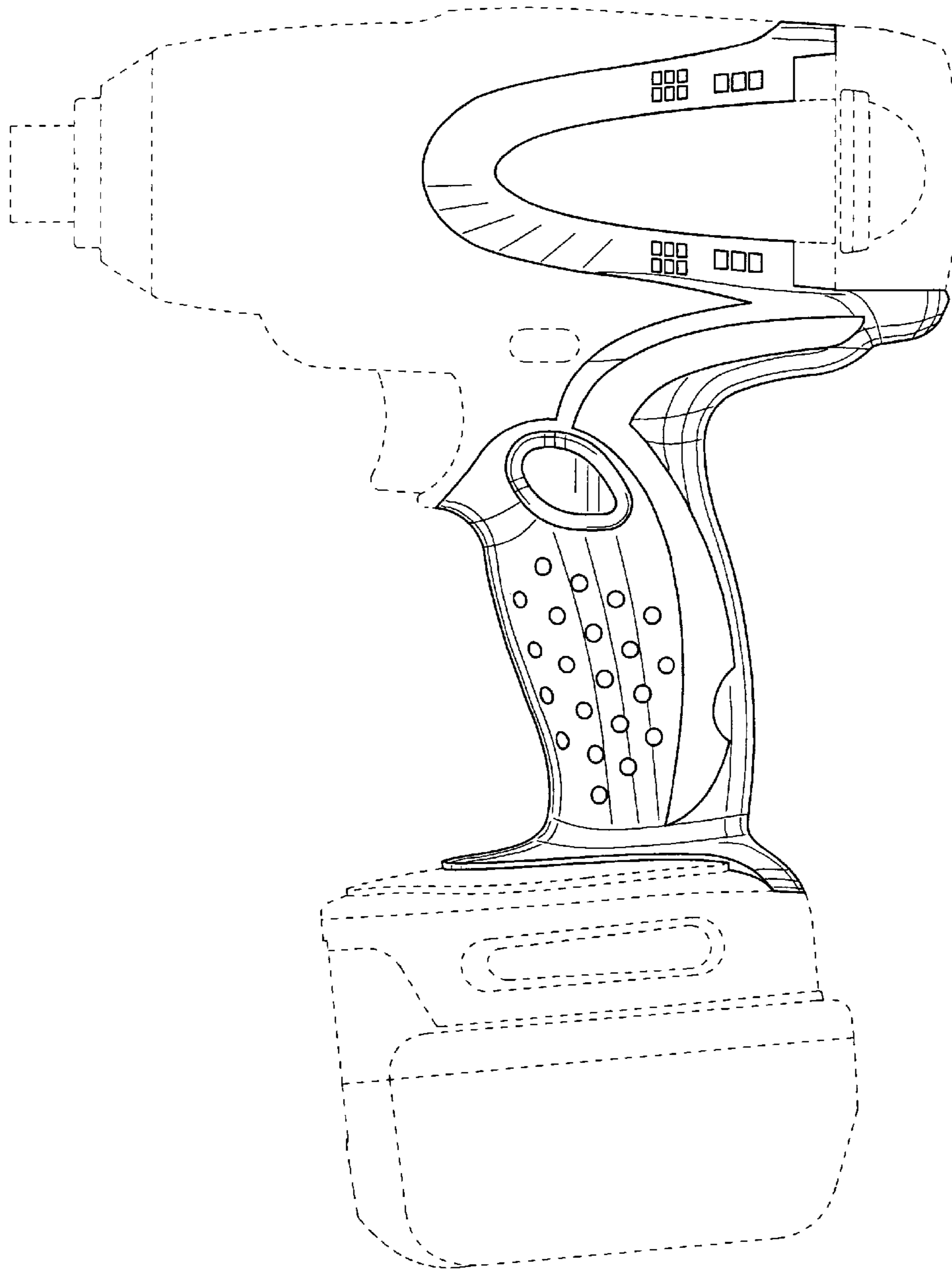

FIG. 3

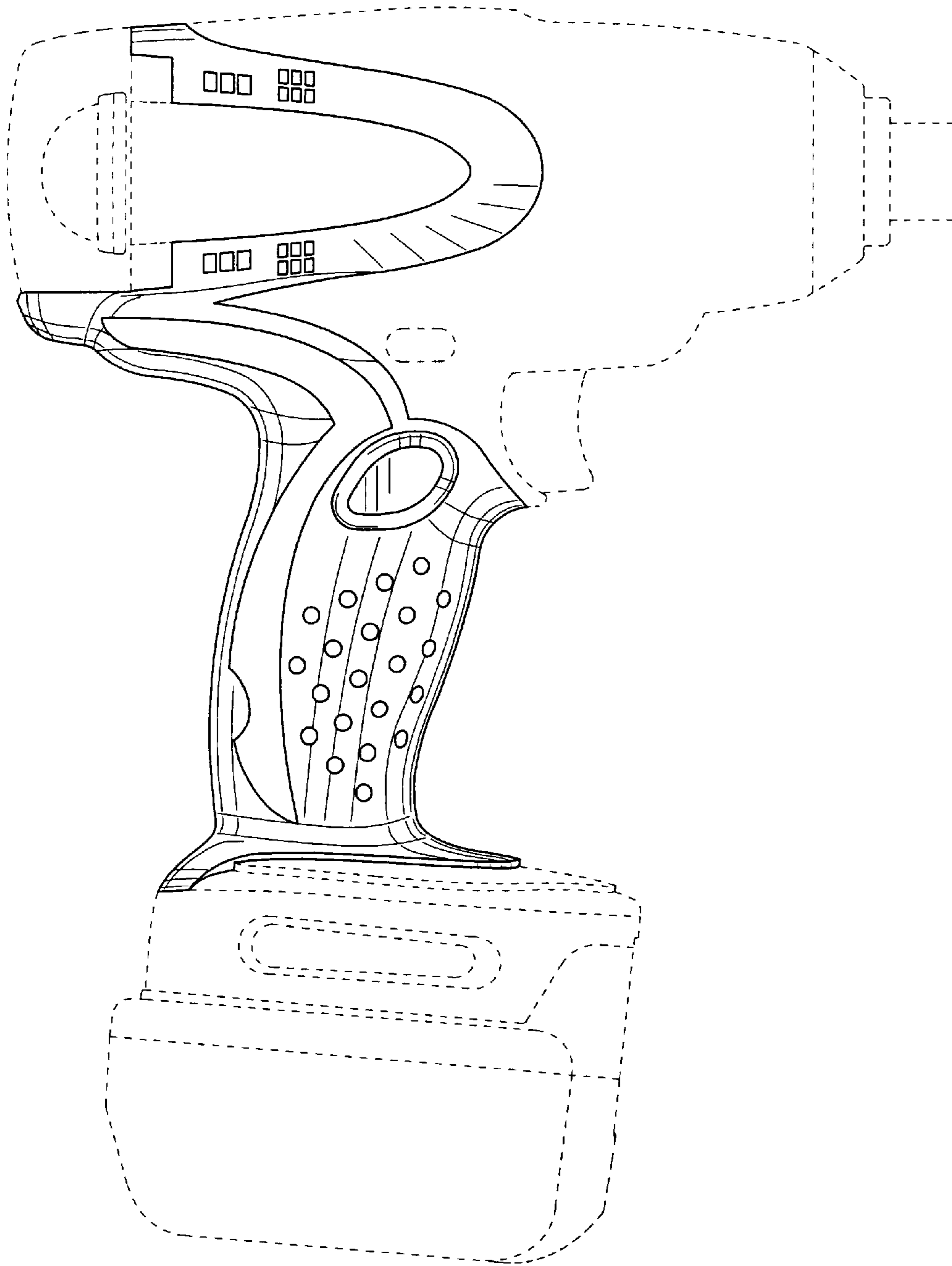

FIG. 4

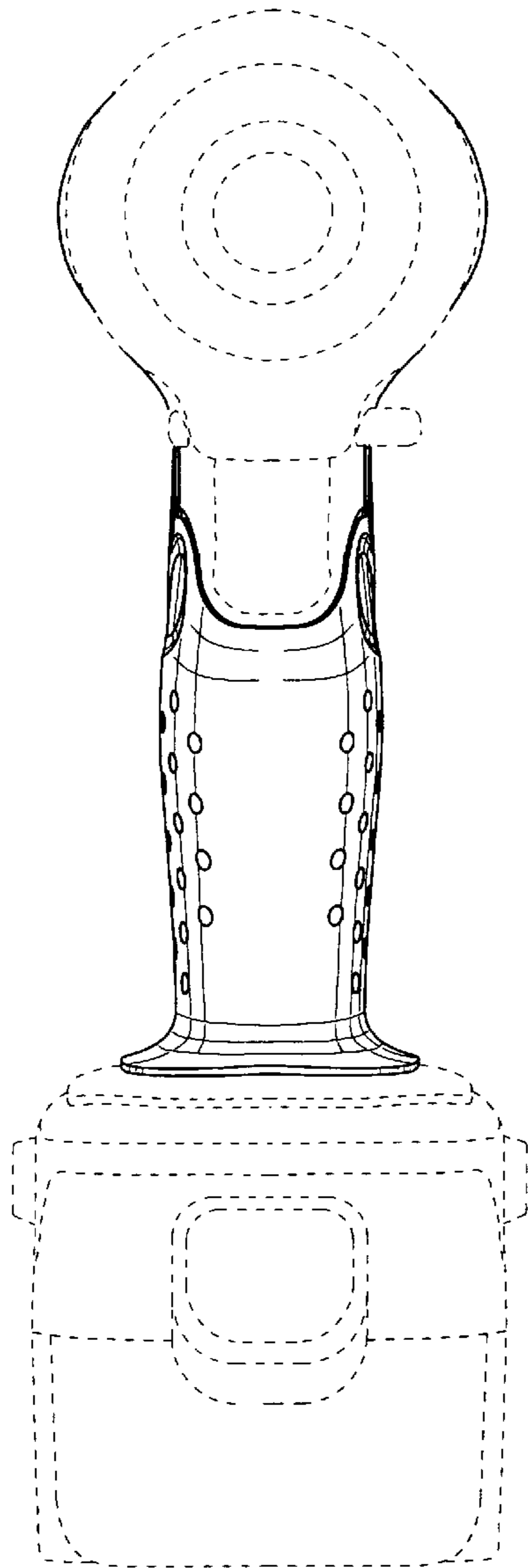

FIG. 5

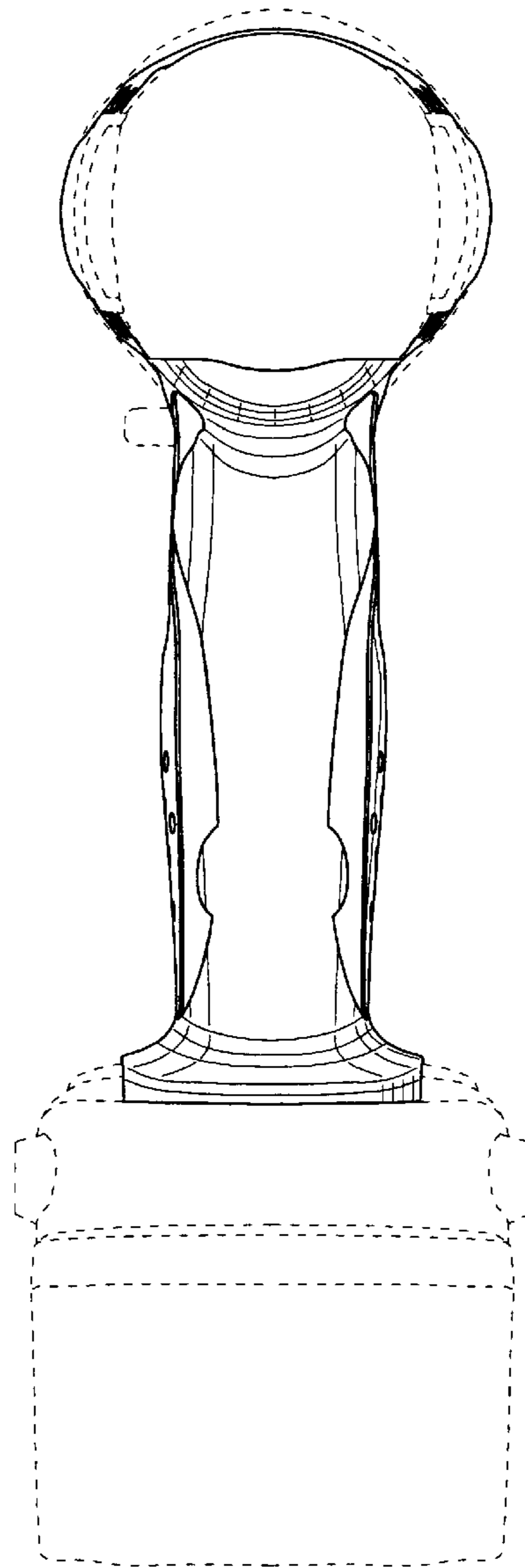

FIG. 6

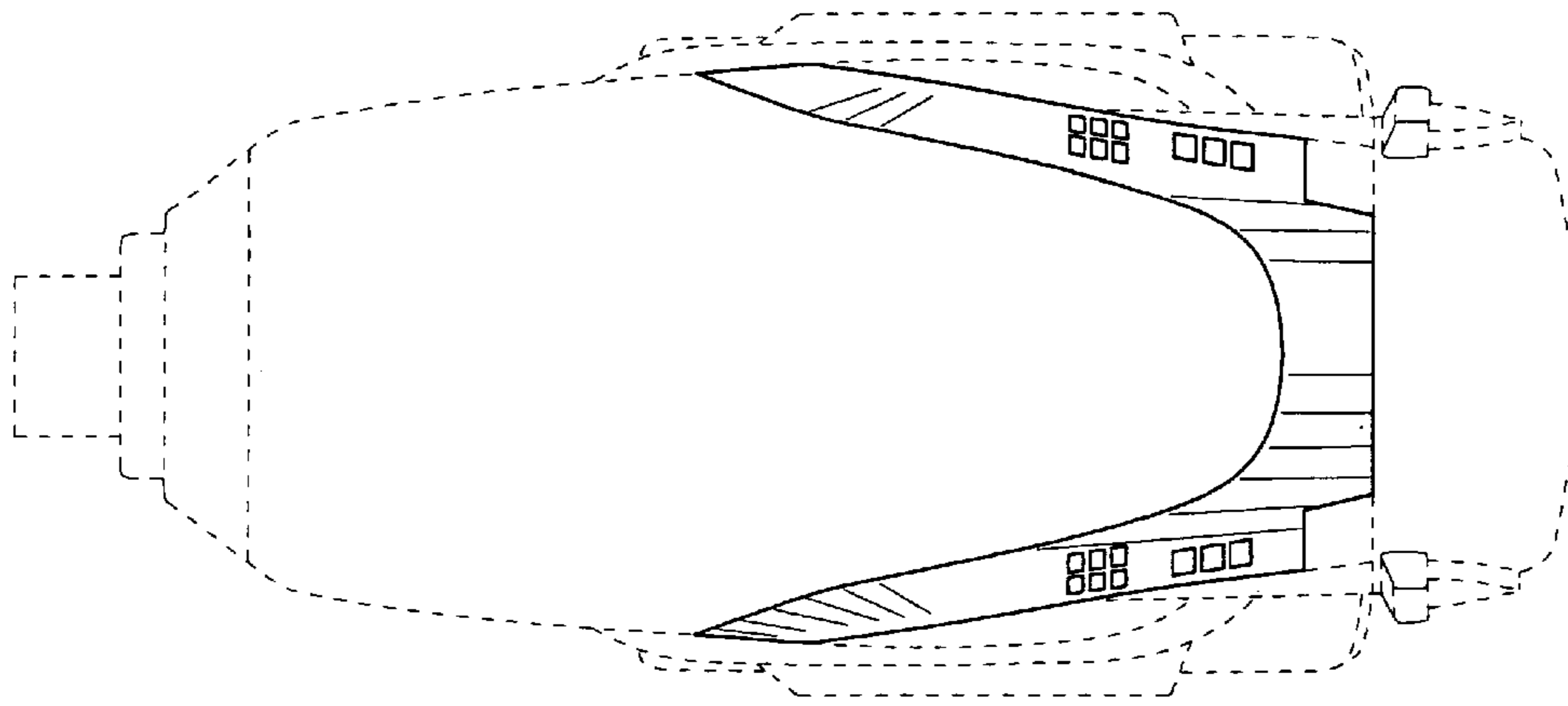

FIG. 7

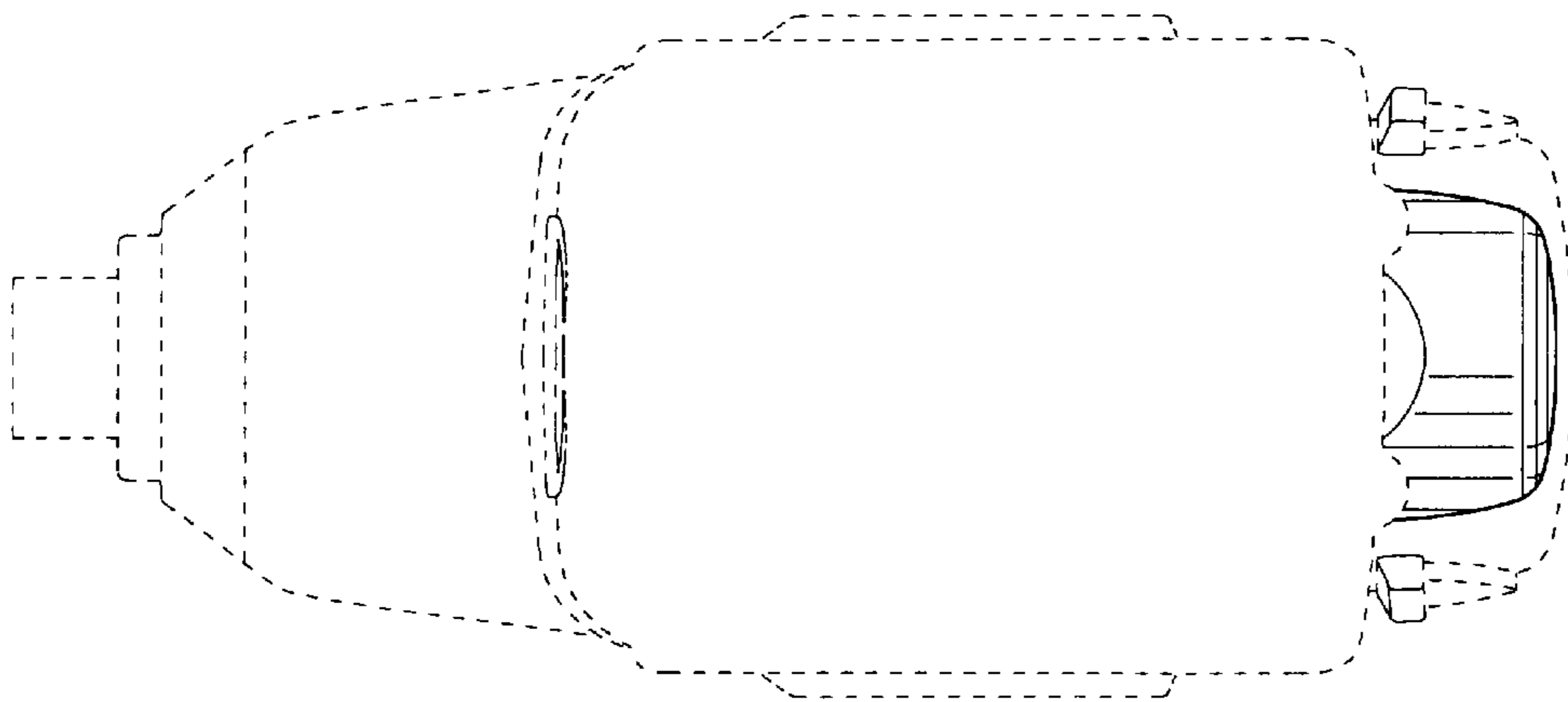

FIG. 8