



US00D526700S

(12) **United States Design Patent**
Schaffeld et al.

(10) **Patent No.:** **US D526,700 S**

(45) **Date of Patent:** **** *Aug. 15, 2006**

(54) **FAUCET SPOUT HUB**

(75) Inventors: **John Schaffeld**, Marshfield, MA (US);
Steffen Koury, Charlestown, MA (US)

(73) Assignee: **Masco Corporation of Indiana**,
Indianapolis, IN (US)

(*) Notice: This patent is subject to a terminal disclaimer.

(**) Term: **14 Years**

(21) Appl. No.: **29/219,930**

(22) Filed: **Dec. 23, 2004**

(51) **LOC (8) Cl.** **23-01**

(52) **U.S. Cl.** **D23/249**; D23/238

(58) **Field of Classification Search** D23/238-257;
4/675-678; 137/801

See application file for complete search history.

(56) **References Cited**

U.S. PATENT DOCUMENTS

- D461,540 S * 8/2002 Gottwald D23/255
- D468,397 S * 1/2003 Czerwinski, Jr. D23/238
- D468,398 S * 1/2003 Ziemann D23/238

- D477,858 S * 7/2003 Friedrich D23/238
- D478,150 S * 8/2003 Friedrich D23/238
- D493,510 S * 7/2004 Shahar D23/238
- D511,561 S * 11/2005 Kulig D23/238

* cited by examiner

Primary Examiner—Louis S. Zarfes

Assistant Examiner—Gregory Andoll

(74) *Attorney, Agent, or Firm*—Kwadjo Adusei-Poku;
Lloyd D. Doigan

(57) **CLAIM**

The ornamental design for a faucet spout hub, as shown and described.

DESCRIPTION

FIG. 1 is a front perspective view of a faucet spout hub showing my design;

FIG. 2 is a front elevational view thereof;

FIG. 3 is a rear elevational view thereof;

FIG. 4 is a right side elevational view, the left side elevational view being a mirror image thereof;

FIG. 5 is a top plan view thereof; and,

FIG. 6 is a rear perspective view thereof.

The broken lines in the Figures are for illustrative purposes only and form no part of the claimed design.

1 Claim, 6 Drawing Sheets

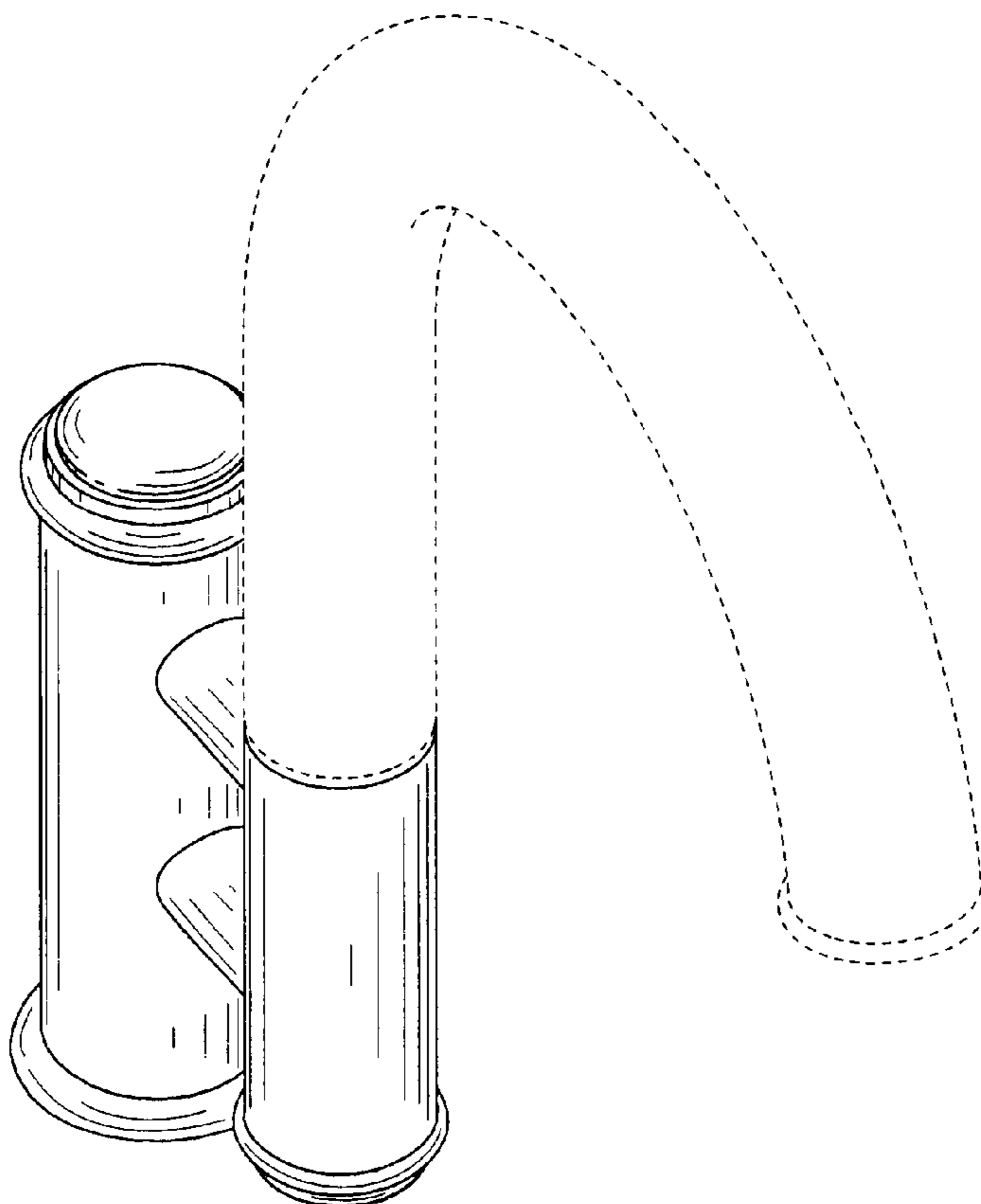

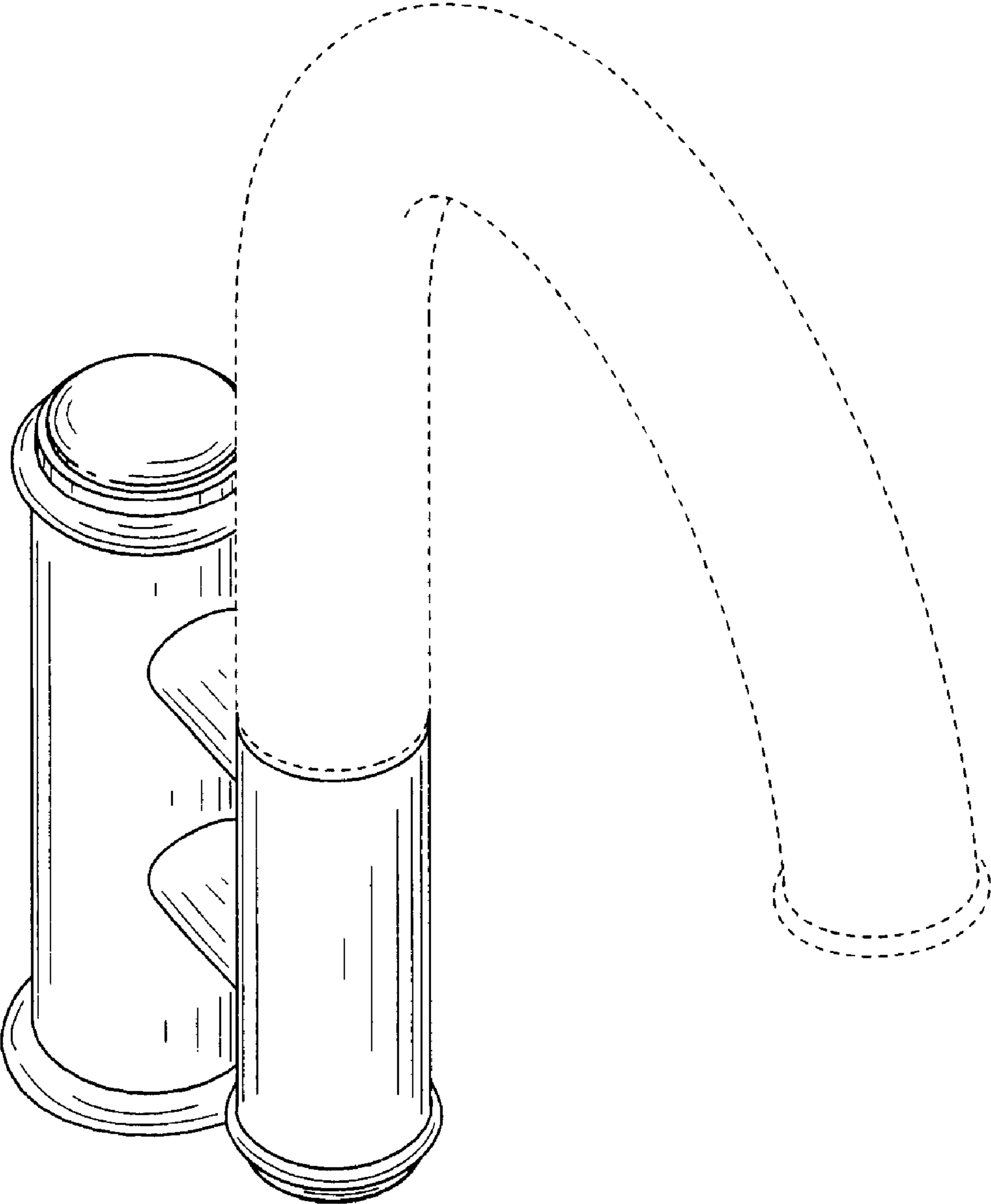

FIG. 1

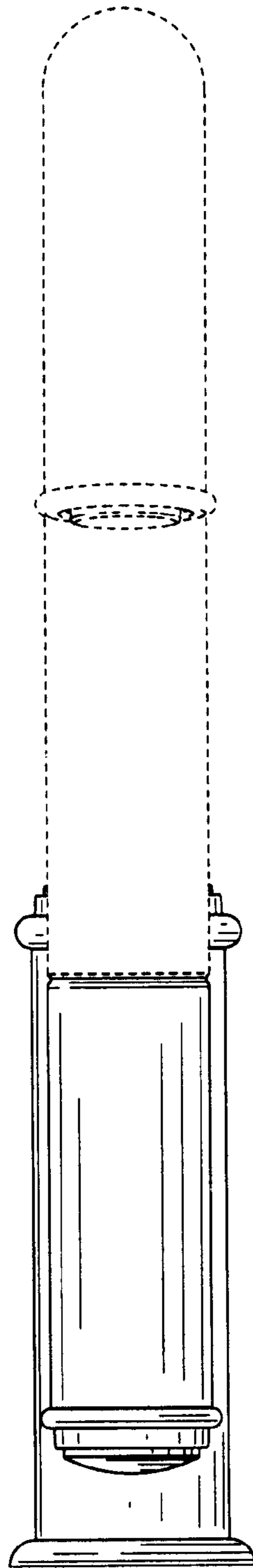

FIG. 2

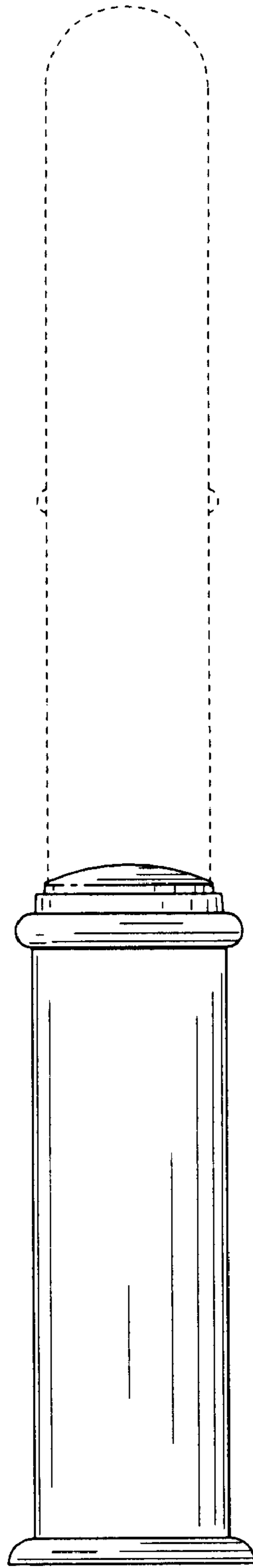

FIG. 3

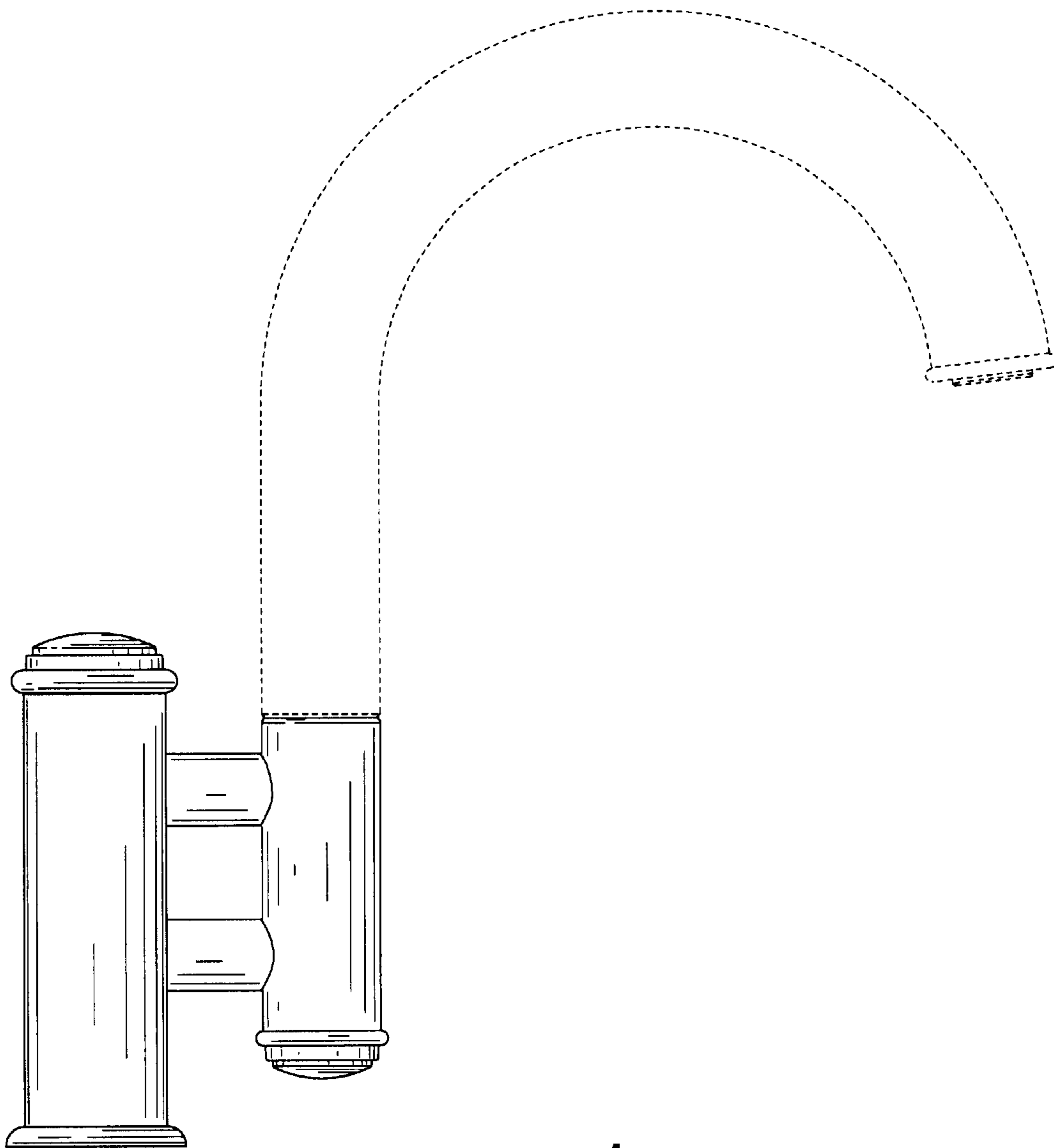

FIG. 4

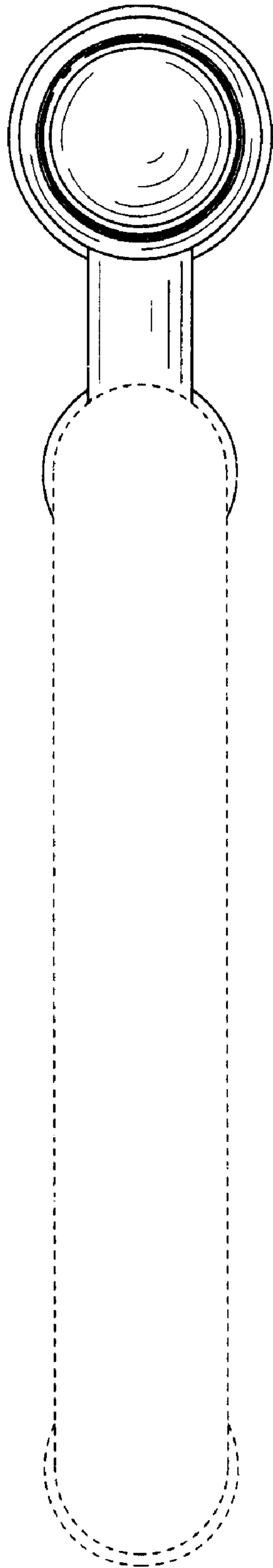

FIG. 5

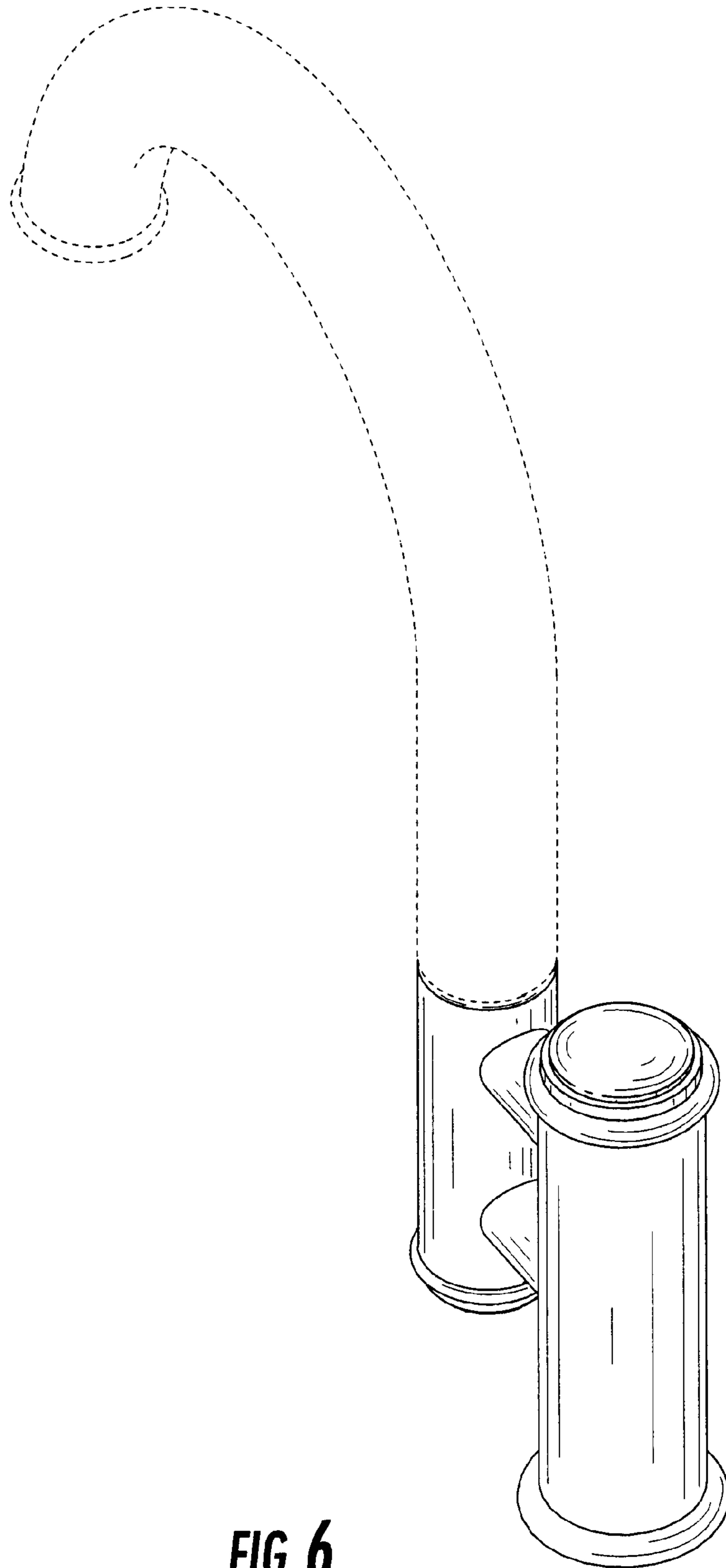

FIG. 6