

US00D526316S

(12) **United States Design Patent**  
**Lauffer et al.**

(10) **Patent No.:** **US D526,316 S**  
(45) **Date of Patent:** **\*\* Aug. 8, 2006**

(54) **INFORMATION HANDLING SYSTEM HOUSING**

(75) Inventors: **Scott Lauffer**, Austin, TX (US);  
**Robert Brunner**, San Francisco, CA (US);  
**Kenneth Musgrave**, Austin, TX (US);  
**Symon Whitehorn**, Sausalito, CA (US);  
**Crispian G. Tompkin**, Los Angeles, CA (US)

(73) Assignee: **Dell Products L.P.**, Round Rock, TX (US)

(\*\*) Term: **14 Years**

(21) Appl. No.: **29/234,456**

(22) Filed: **Jul. 19, 2005**

(51) **LOC (8) Cl.** ..... **14-02**

(52) **U.S. Cl.** ..... **D14/300**

(58) **Field of Classification Search** ..... D14/349-356,  
D14/300, 301, 308; D13/162, 184, 199; 312/223.1-223.2;  
360/99.01-99.12; 369/34.01, 36.01; 361/680-686,  
361/690-696

See application file for complete search history.

(56) **References Cited**

**U.S. PATENT DOCUMENTS**

D226,565 S \* 3/1973 Klepa et al. .... D14/349

D428,005 S \* 7/2000 Takizawa et al. .... D14/349  
6,231,140 B1 \* 5/2001 Chen ..... 312/223.2  
6,296,333 B1 \* 10/2001 Lee et al. .... 312/223.2  
D452,239 S \* 12/2001 Kitayama et al. .... D14/349  
D468,737 S \* 1/2003 Chien et al. .... D14/349  
D478,586 S 8/2003 Lee et al. .... D14/349  
D494,169 S 8/2004 Lin ..... D14/349  
D497,162 S 10/2004 Neal et al. .... D14/349  
D504,895 S 5/2005 Frank et al. .... D14/441

\* cited by examiner

*Primary Examiner*—Freda S. Nunn

(74) *Attorney, Agent, or Firm*—Hamilton & Terrile, LLP;  
Robert W. Holland

(57) **CLAIM**

The ornamental design for an information handling system housing, as shown and described.

**DESCRIPTION**

FIG. 1 is a frontal angled perspective view of the information handling system housing comprising the present invention, the broken lines are shown for illustrative purposes only and form no part of the claimed design; FIG. 2 is a front elevation view thereof; FIG. 3 is a right side elevation view thereof; FIG. 4 is a left side elevation view thereof; FIG. 5 is a back elevation view thereof; and, FIG. 6 is a top plan view thereof.

**1 Claim, 4 Drawing Sheets**

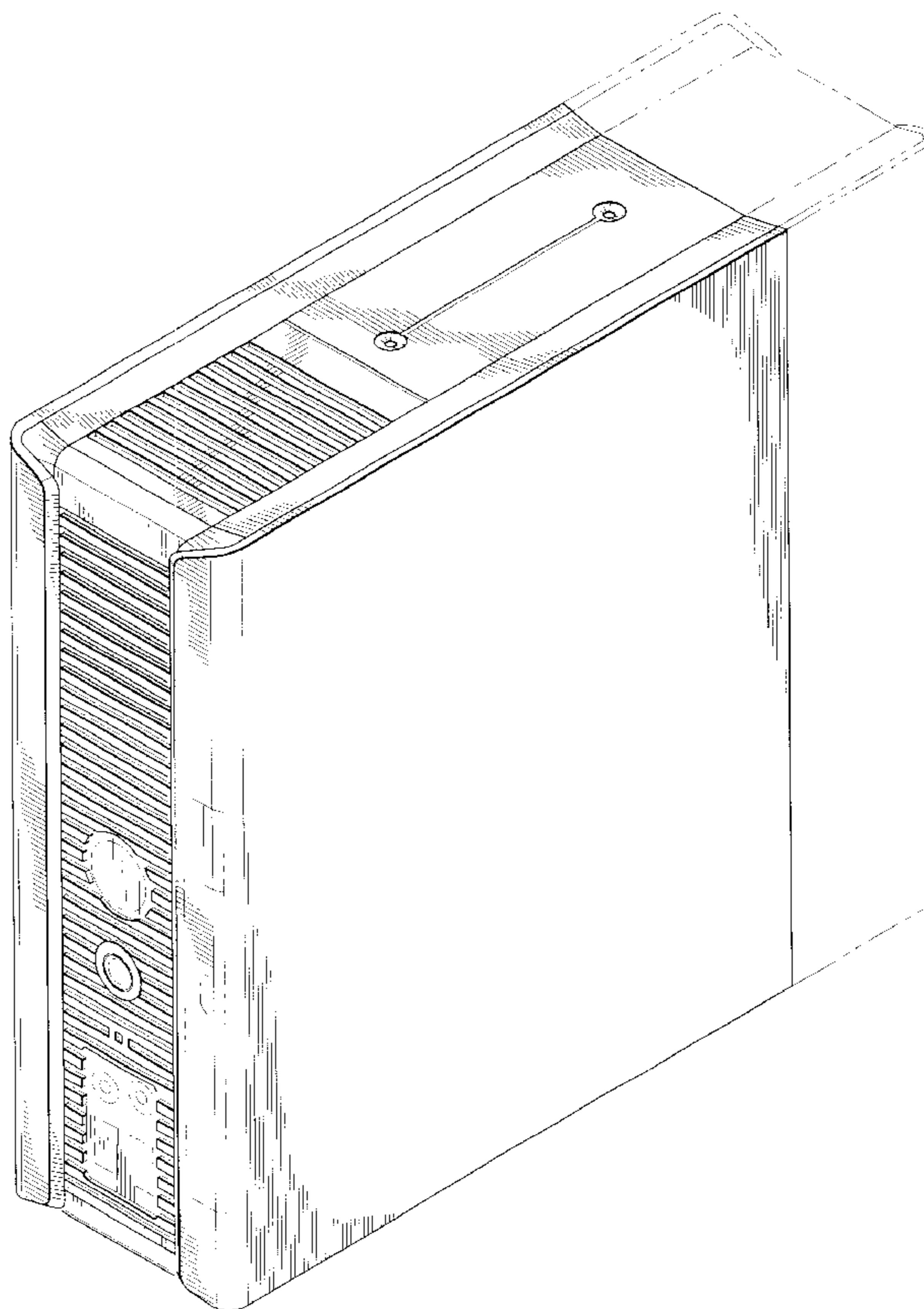

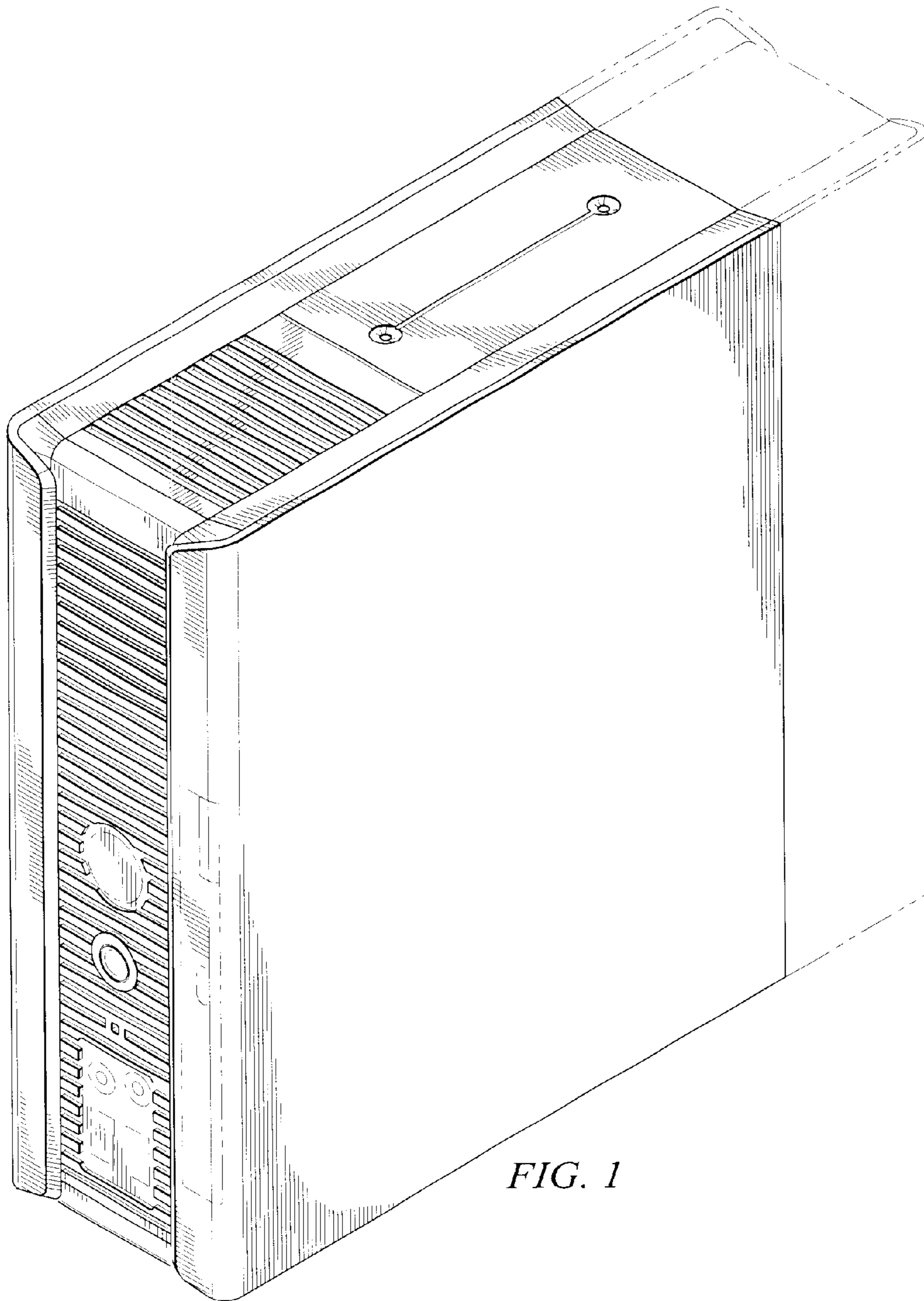

FIG. 1

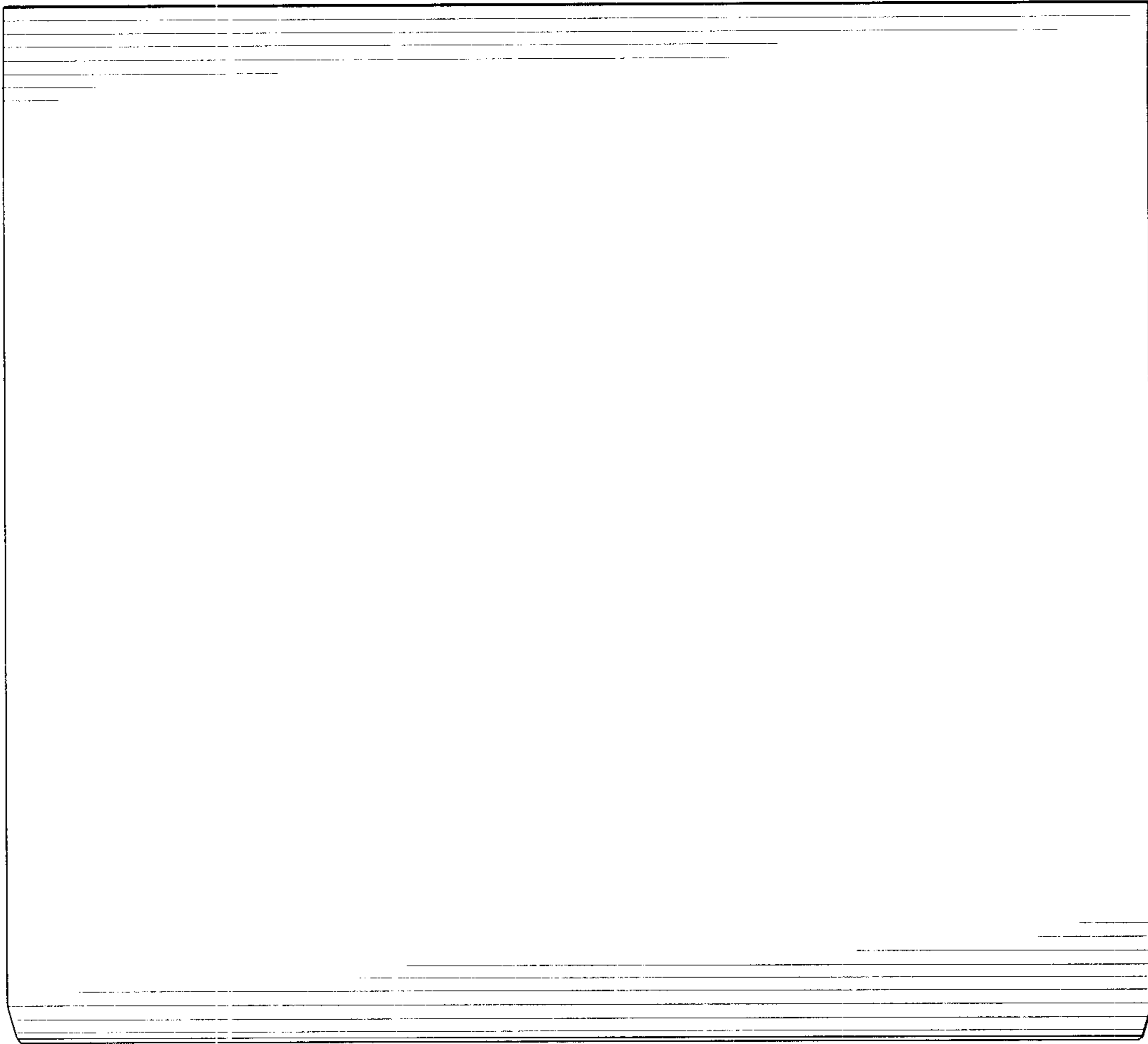

FIG. 3

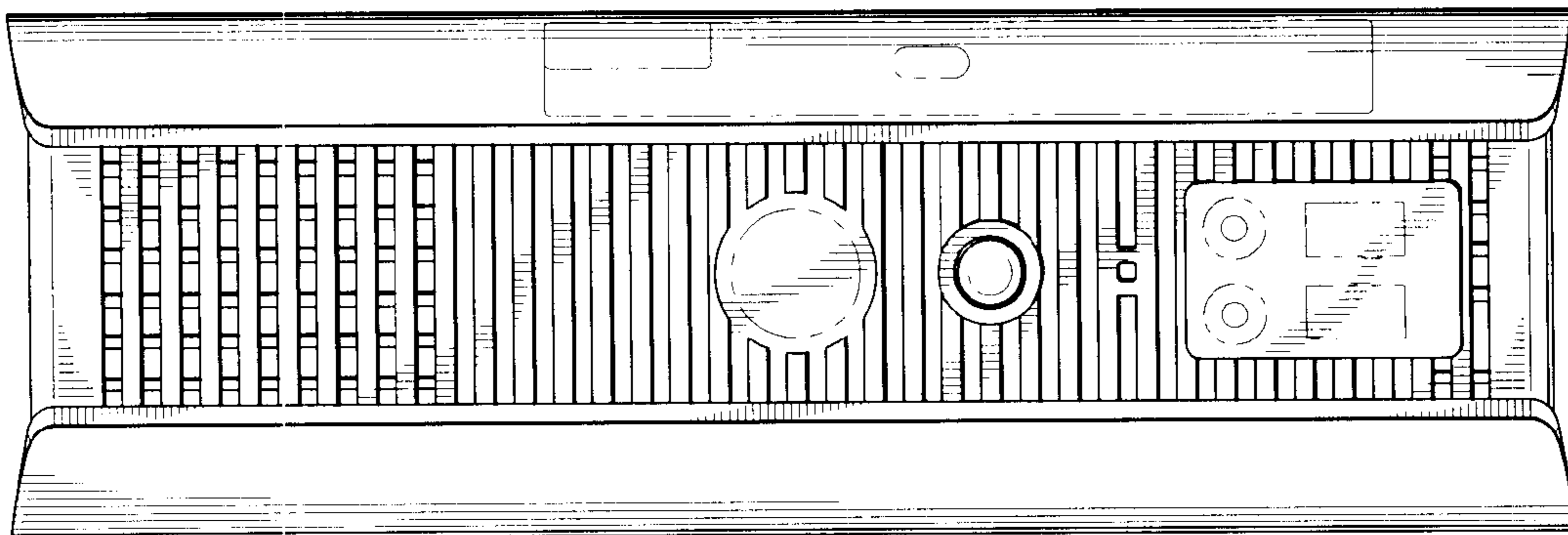

FIG. 2

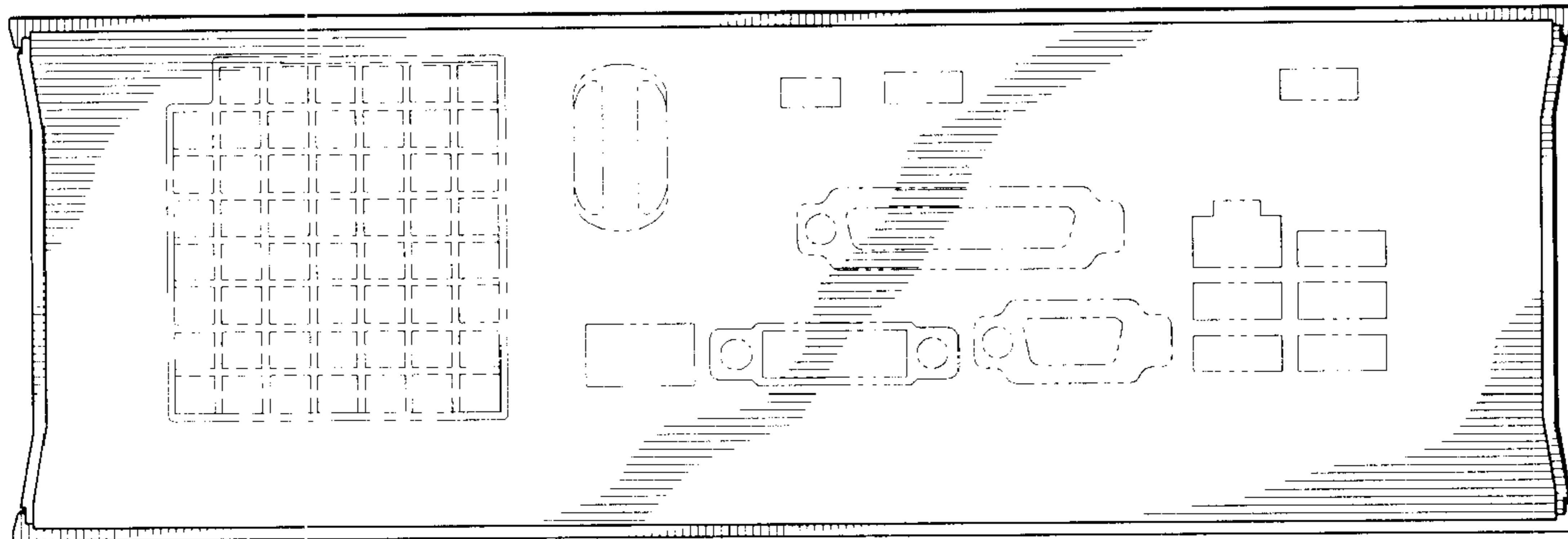

FIG. 5

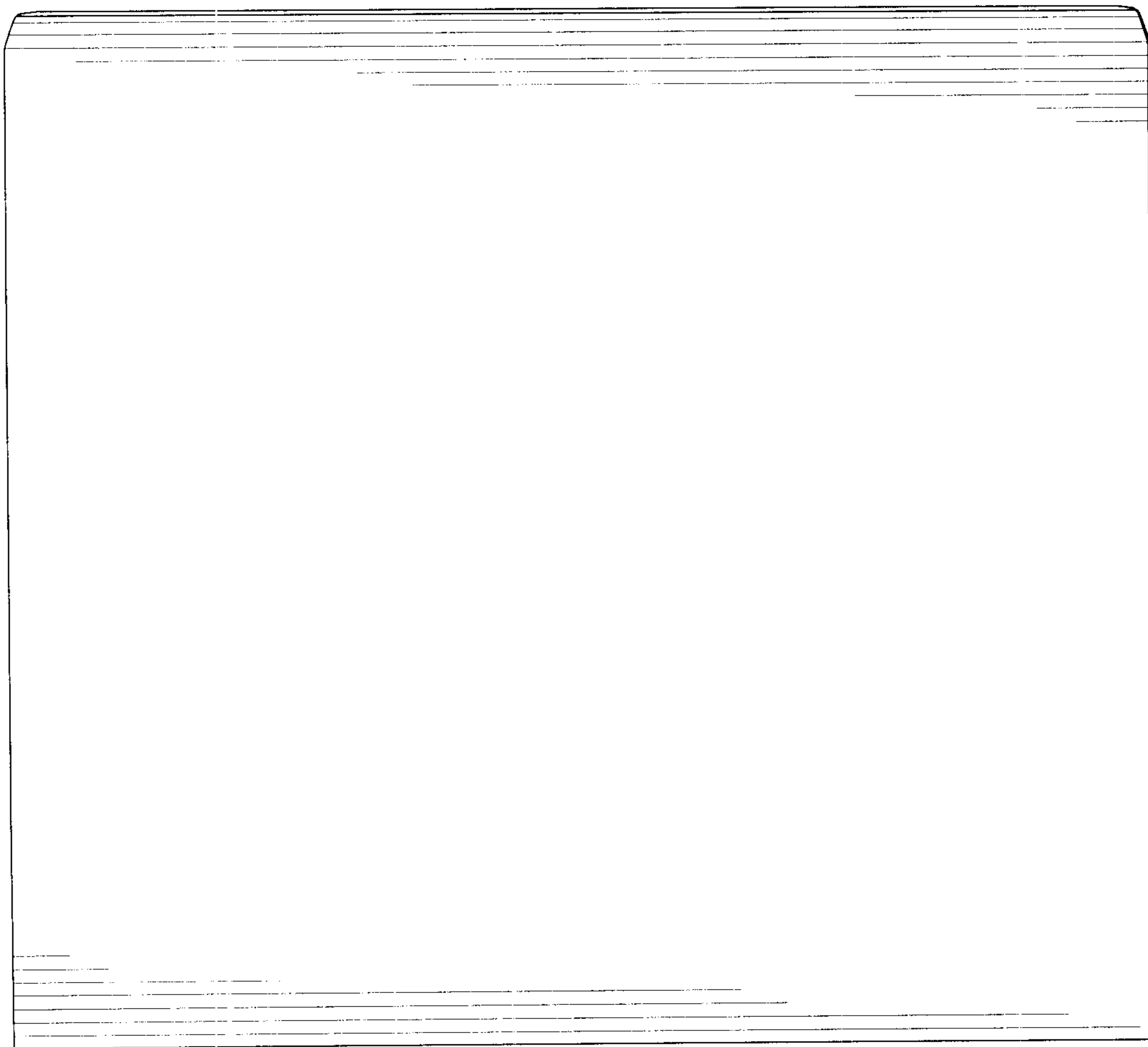
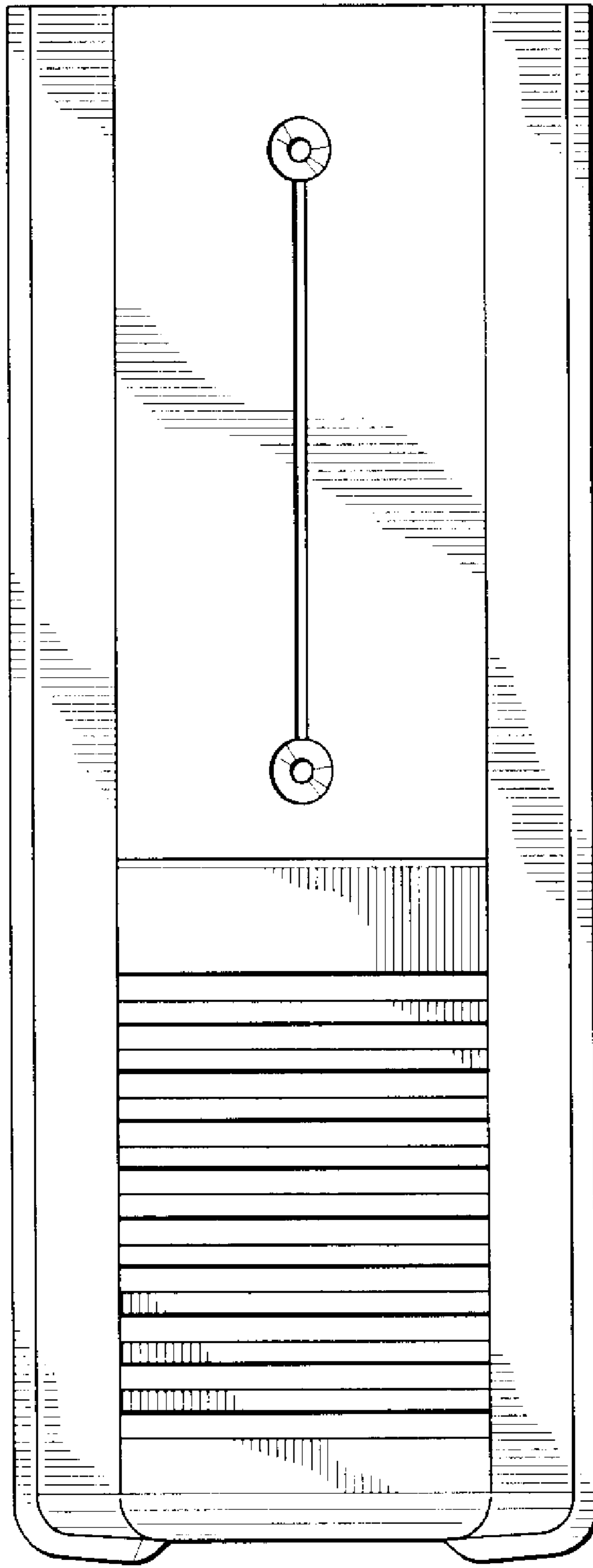

FIG. 4



*FIG. 6*