



US00D526276S

(12) **United States Design Patent**
Shiraishi et al.

(10) **Patent No.:** **US D526,276 S**

(45) **Date of Patent:** **** Aug. 8, 2006**

(54) **HOUSING FOR AN OPTICAL CONNECTOR**

2003/0174971 A1 * 9/2003 Shigenaga et al. 385/71
2005/0238291 A1 * 10/2005 Sasaki et al. 385/71

(75) Inventors: **Makoto Shiraishi**, Nishikamo-gun (JP);
Yutaka Katsuyama, Sakai (JP)

FOREIGN PATENT DOCUMENTS

(73) Assignee: **J.S.T. Mfg. Co., Ltd.**, Osaka (JP)

TW 482540 S 4/2002

(**) Term: **14 Years**

OTHER PUBLICATIONS

(21) Appl. No.: **29/207,440**

Office Action of Taiwanese Design Patent Application
mailed Jun. 14, 2005.

(22) Filed: **Jun. 15, 2004**

* cited by examiner

(30) **Foreign Application Priority Data**

Dec. 26, 2003 (JP) 2003-038795

Primary Examiner—Stella Reid

Assistant Examiner—Daniel Bui

(51) **LOC (8) Cl.** **13-03**

(52) **U.S. Cl.** **D13/146**

(58) **Field of Classification Search** D13/133,
D13/146–147, 154, 184, 199; 385/55, 59–60,
385/71, 78, 80, 83, 89–91; 439/353, 358,
439/660, 682

(74) *Attorney, Agent, or Firm*—Rader, Fishman & Grauer
PLLC

See application file for complete search history.

(57) **CLAIM**

The ornamental design for a housing for an optical connector, as shown and described.

(56) **References Cited**

U.S. PATENT DOCUMENTS

- D200,645 S * 3/1965 Schumacher D13/146
- D203,502 S * 1/1966 Dell et al. D13/147
- 3,366,729 A * 1/1968 Pauza 174/138 R
- 5,815,621 A * 9/1998 Sakai et al. 385/80
- 5,867,620 A * 2/1999 Bunin et al. 385/53
- 6,257,917 B1 * 7/2001 Hyzin 439/358
- 6,409,394 B1 * 6/2002 Ueda et al. 385/80
- 6,604,866 B1 * 8/2003 Kang et al. 385/78
- 2001/0031116 A1 * 10/2001 Katsura et al. 385/55
- 2001/0036341 A1 * 11/2001 Ohtsuka et al. 385/78

DESCRIPTION

FIG. 1 is a perspective view of a housing for an optical connector showing our new design;
FIG. 2 is a top plan view thereof;
FIG. 3 is a bottom plan view thereof;
FIG. 4 is a front elevation view thereof;
FIG. 5 is a right side view thereof, a left side view thereof being a mirror image; and,
FIG. 6 is a rear elevation view thereof.
Portions shown in broken lines in FIGS. 1 and 2 are for illustrative purposes only and form no part of the claimed design.

1 Claim, 1 Drawing Sheet

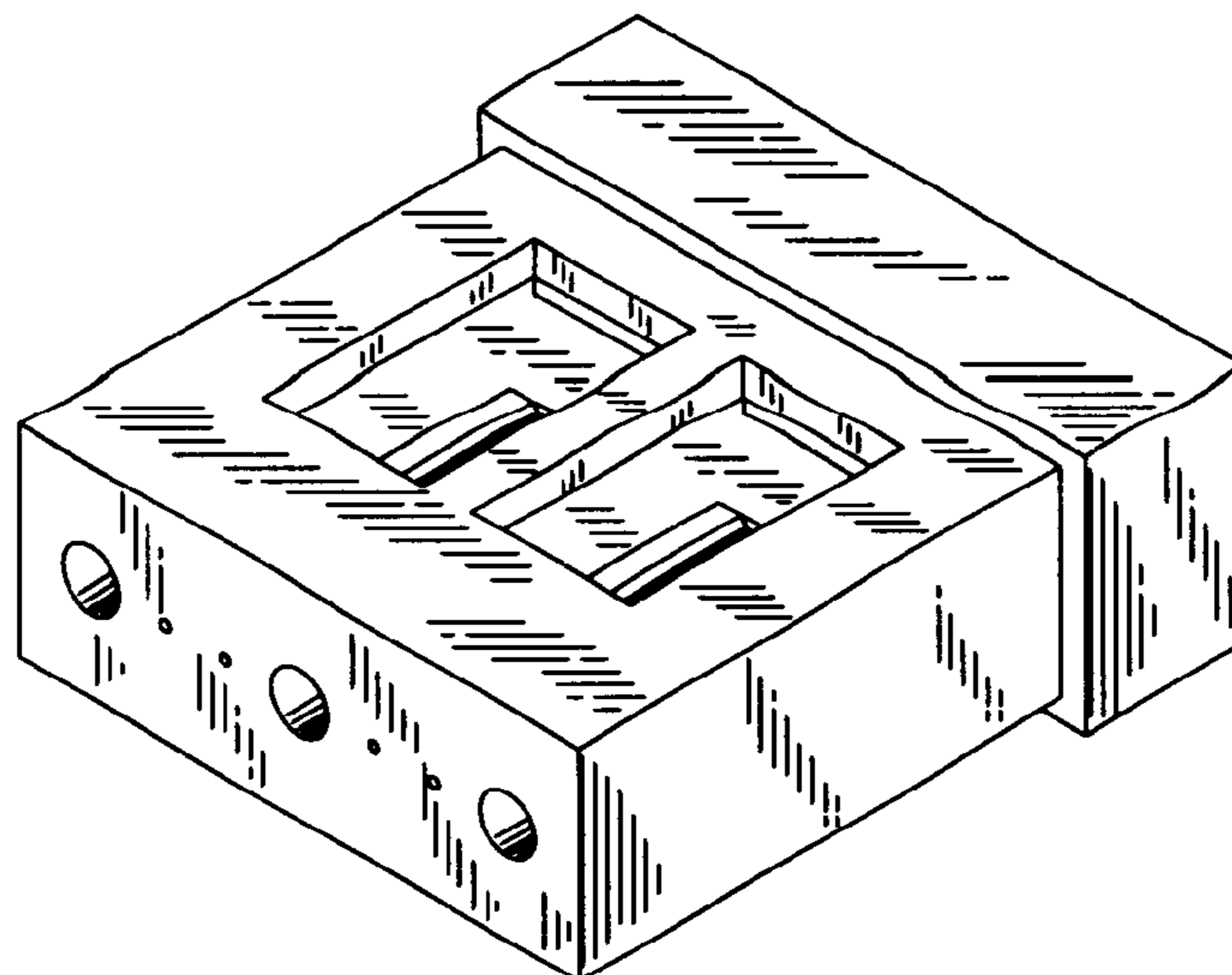

FIG. 1

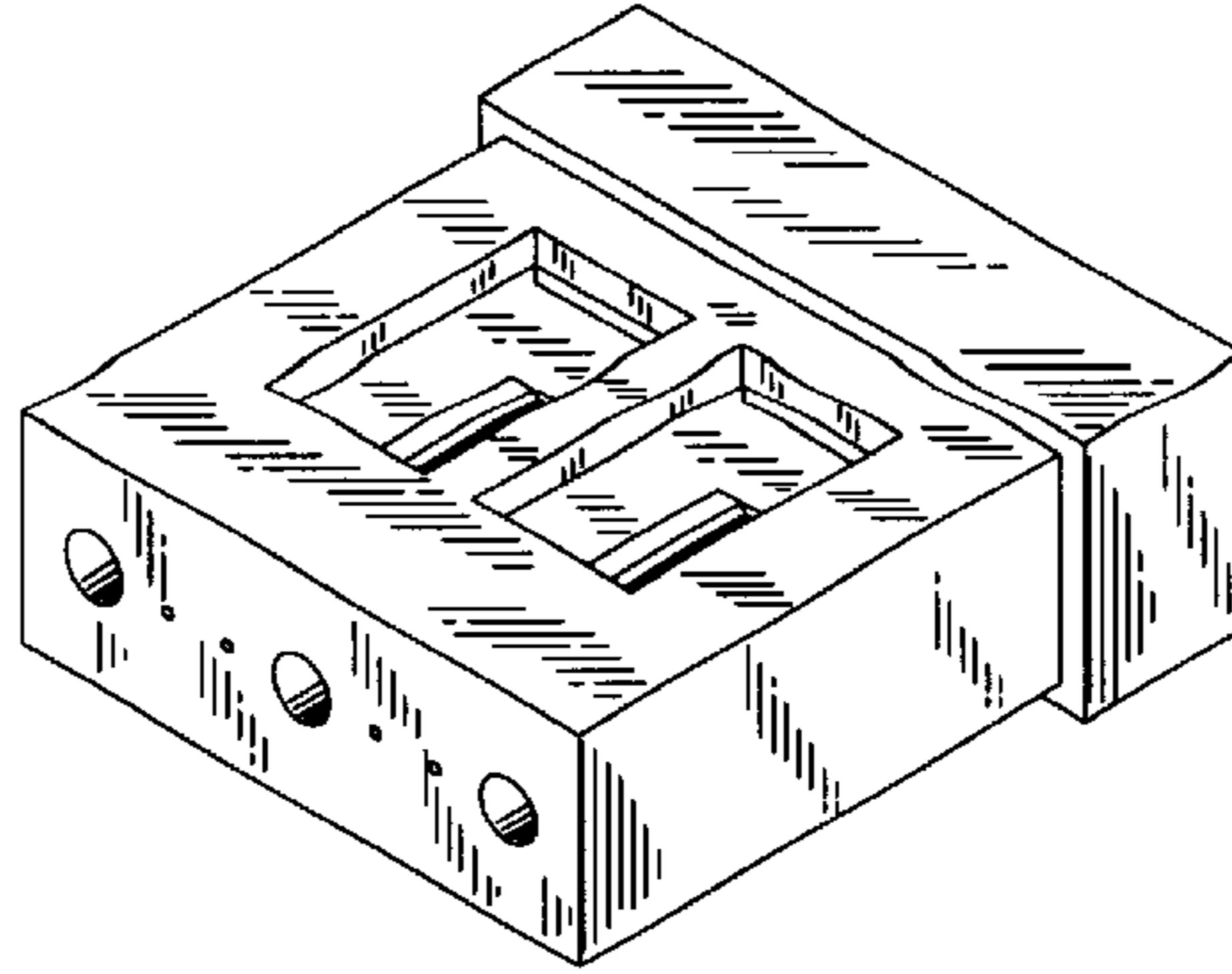

FIG. 2

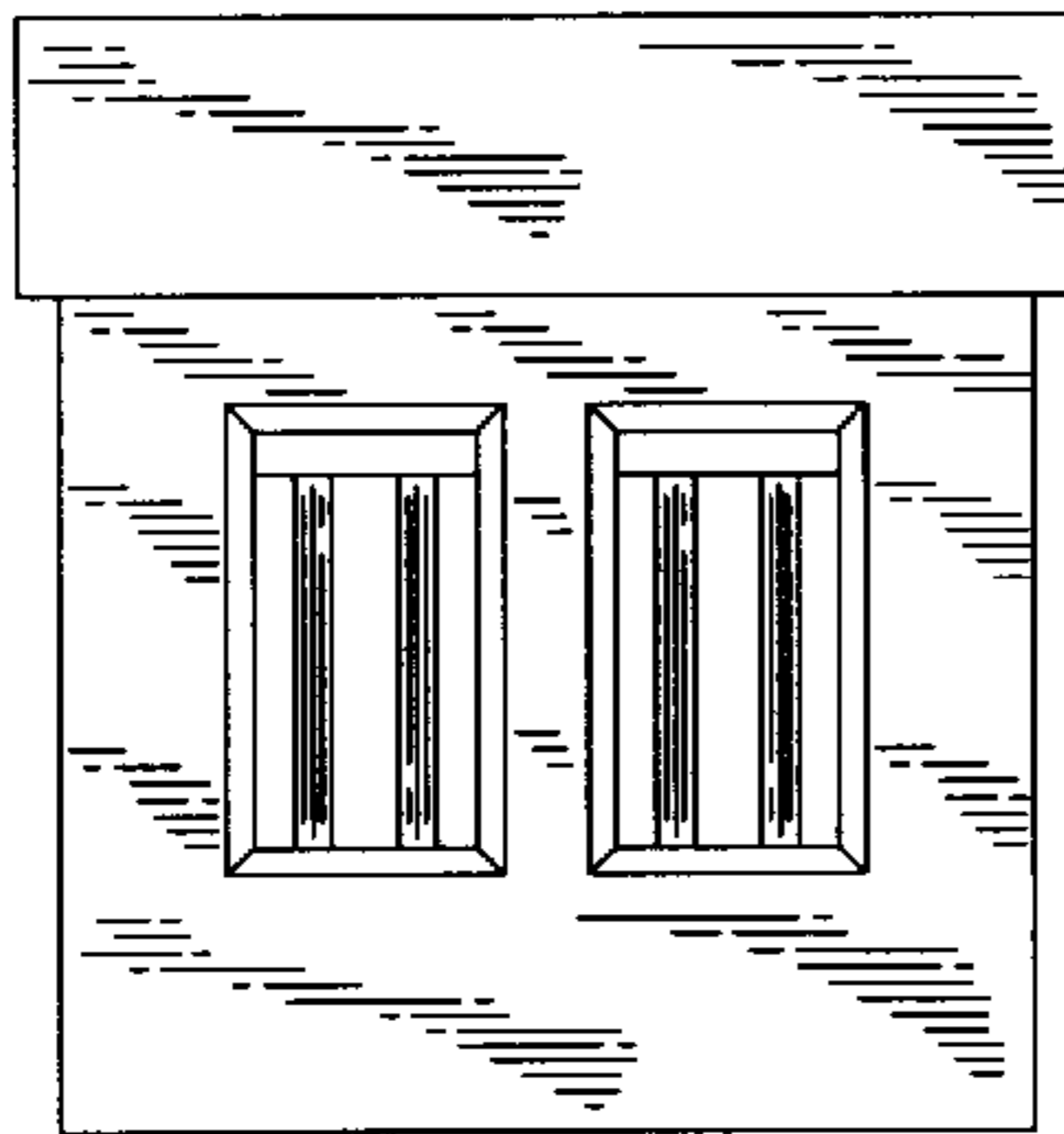

FIG. 3

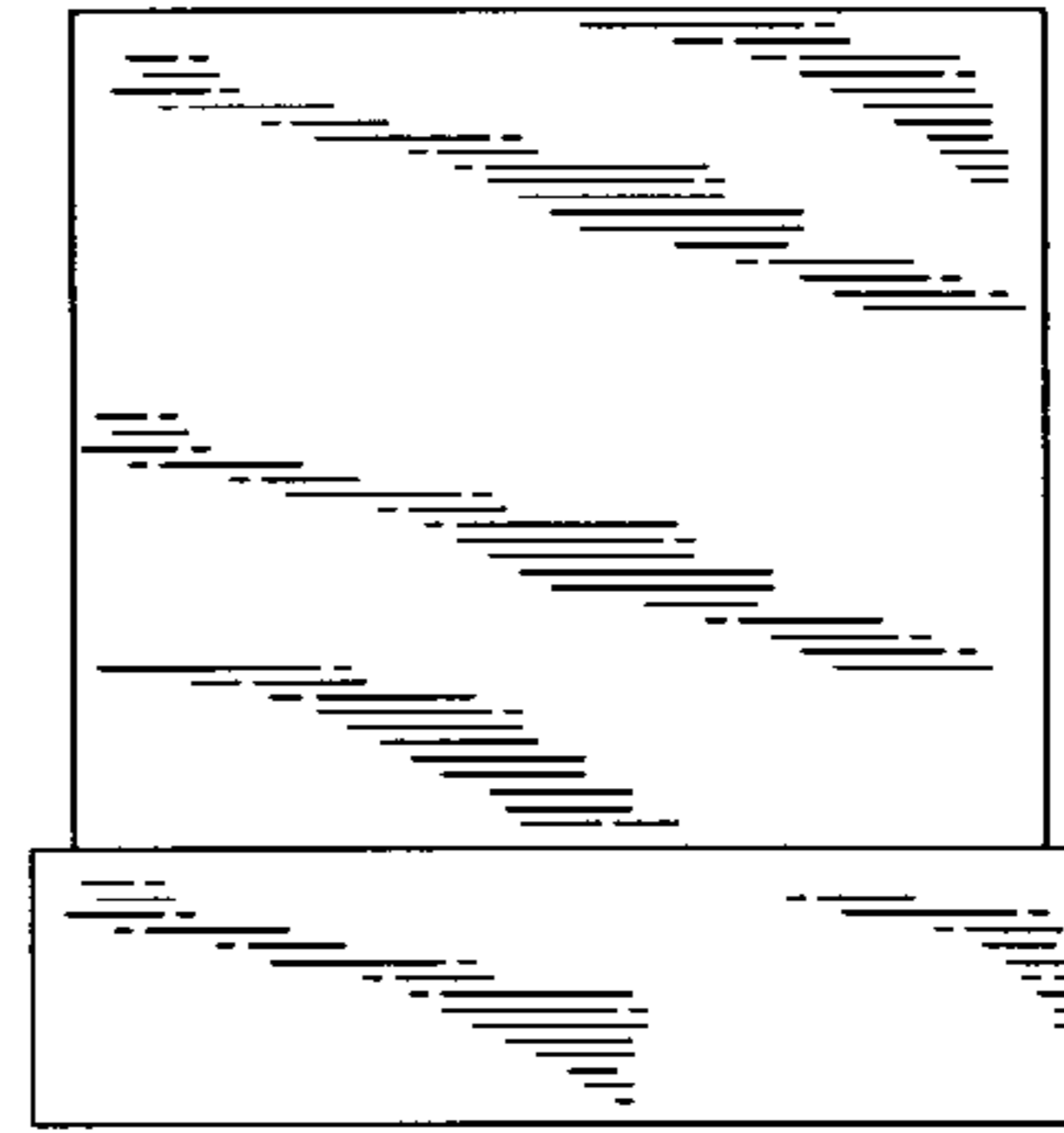

FIG. 4

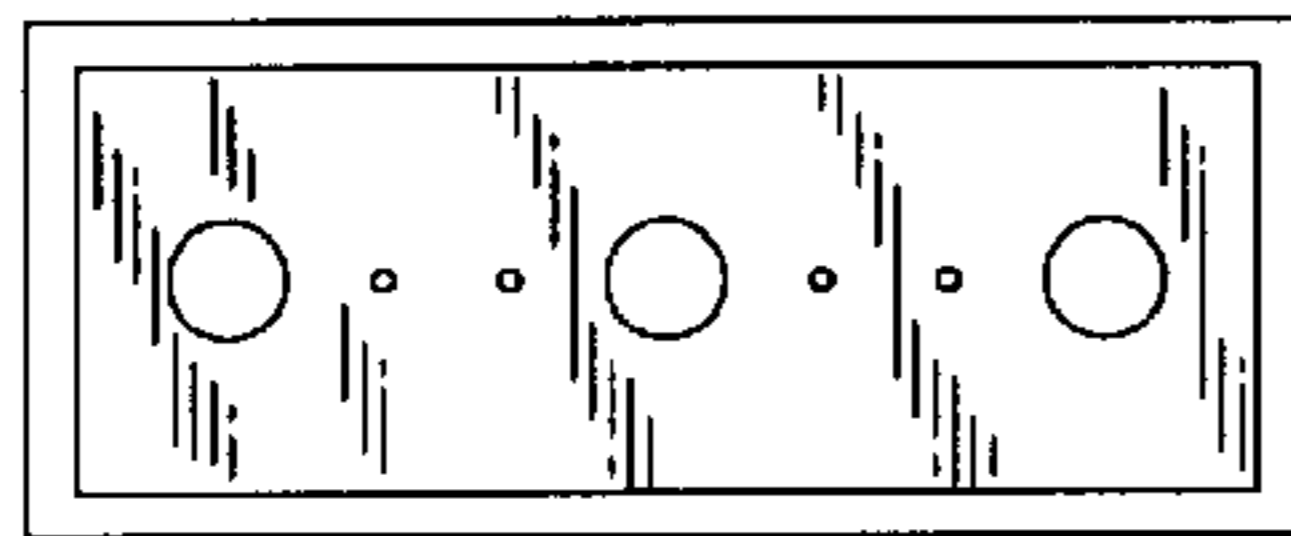

FIG. 5

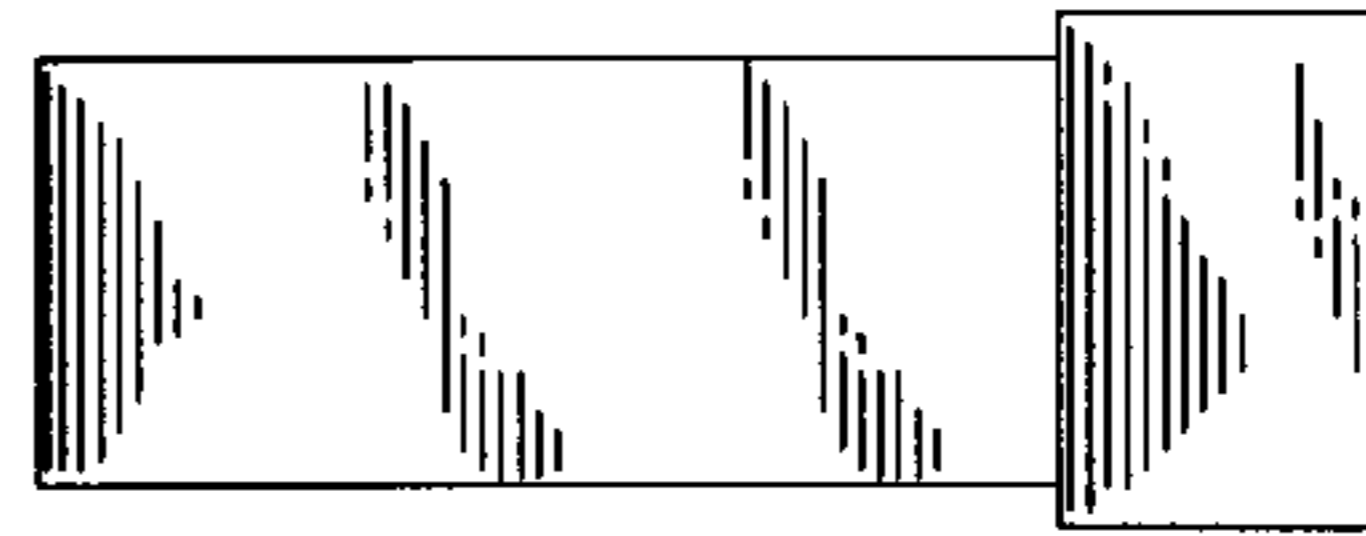

FIG. 6

