

US00D526269S

(12) **United States Design Patent**
Eadie

(10) **Patent No.:** **US D526,269 S**

(45) **Date of Patent:** **** Aug. 8, 2006**

(54) **HIGH SPEED ATTACK ROTORCRAFT**

(75) Inventor: **William J. Eadie**, Cheshire, CT (US)

(73) Assignee: **Sikorsky Aircraft Corporation**,
Stratford, CT (US)

(**) Term: **14 Years**

(21) Appl. No.: **29/231,084**

(22) Filed: **May 31, 2005**

(51) **LOC (8) Cl.** **12-07**

(52) **U.S. Cl.** **D12/327**

(58) **Field of Classification Search** D12/327-329;
244/17.11, 17.19, 17.21

See application file for complete search history.

(56) **References Cited**

U.S. PATENT DOCUMENTS

- D357,894 S * 5/1995 Arnold et al. D12/327
- D361,053 S * 8/1995 Whyte et al. D12/327
- D363,054 S * 10/1995 Taylor et al. D12/327

- D375,077 S * 10/1996 Taylor et al. D12/327
- D388,048 S * 12/1997 Taylor et al. D12/328
- D425,853 S * 5/2000 Caporaletti D12/327

* cited by examiner

Primary Examiner—Marcus A. Jackson

(57) **CLAIM**

The ornamental design for a high speed attack rotorcraft, as shown and described.

DESCRIPTION

FIG. 1 is a perspective view of the high speed attack rotorcraft;
 FIG. 2 is another perspective view thereof;
 FIG. 3 is a left side elevational view thereof;
 FIG. 4 is a right side elevational view thereof;
 FIG. 5 is a top plan view thereof;
 FIG. 6 is a bottom plan view thereof;
 FIG. 7 is a front elevational view thereof; and,
 FIG. 8 is a rear elevational view thereof.

1 Claim, 5 Drawing Sheets

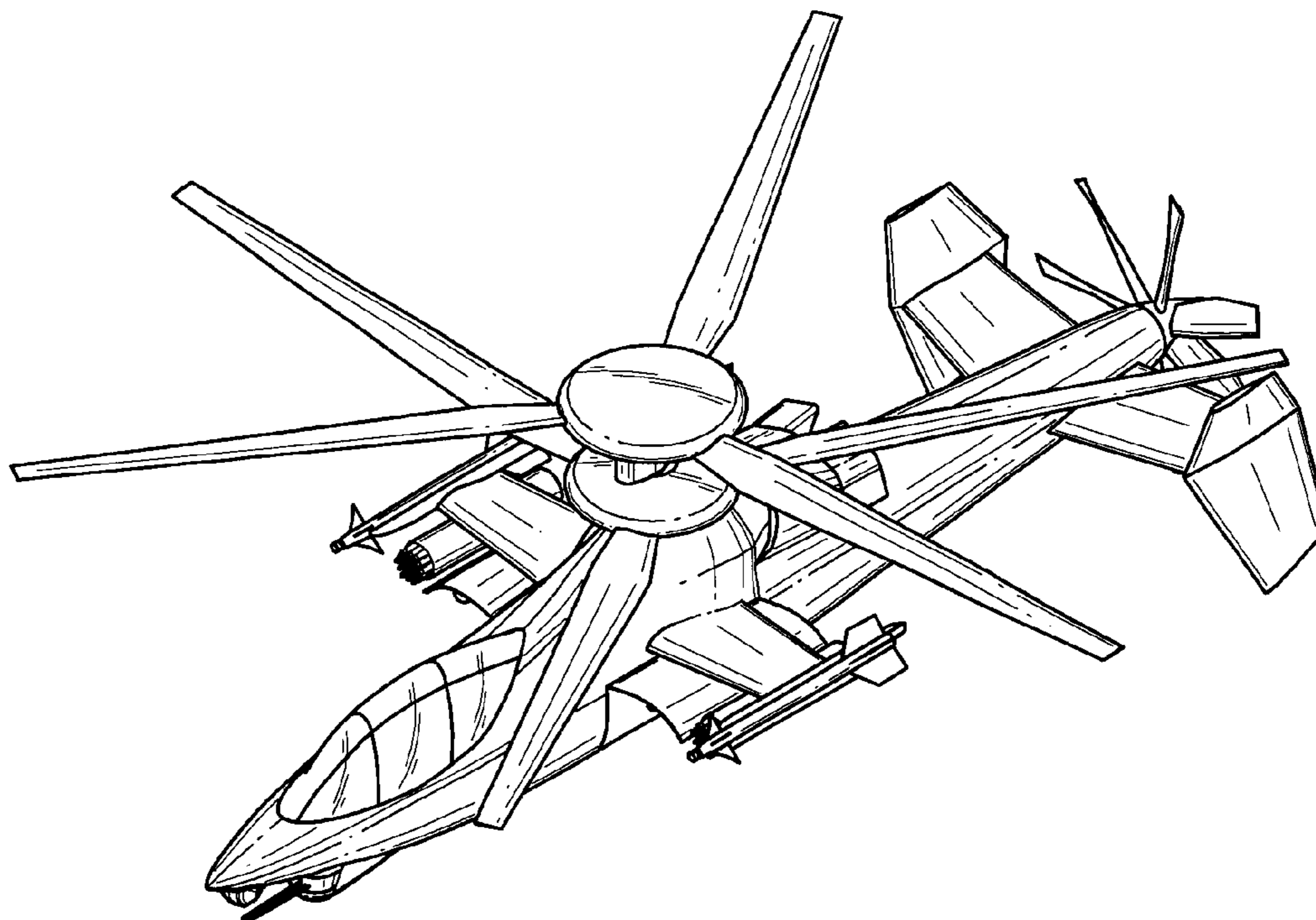

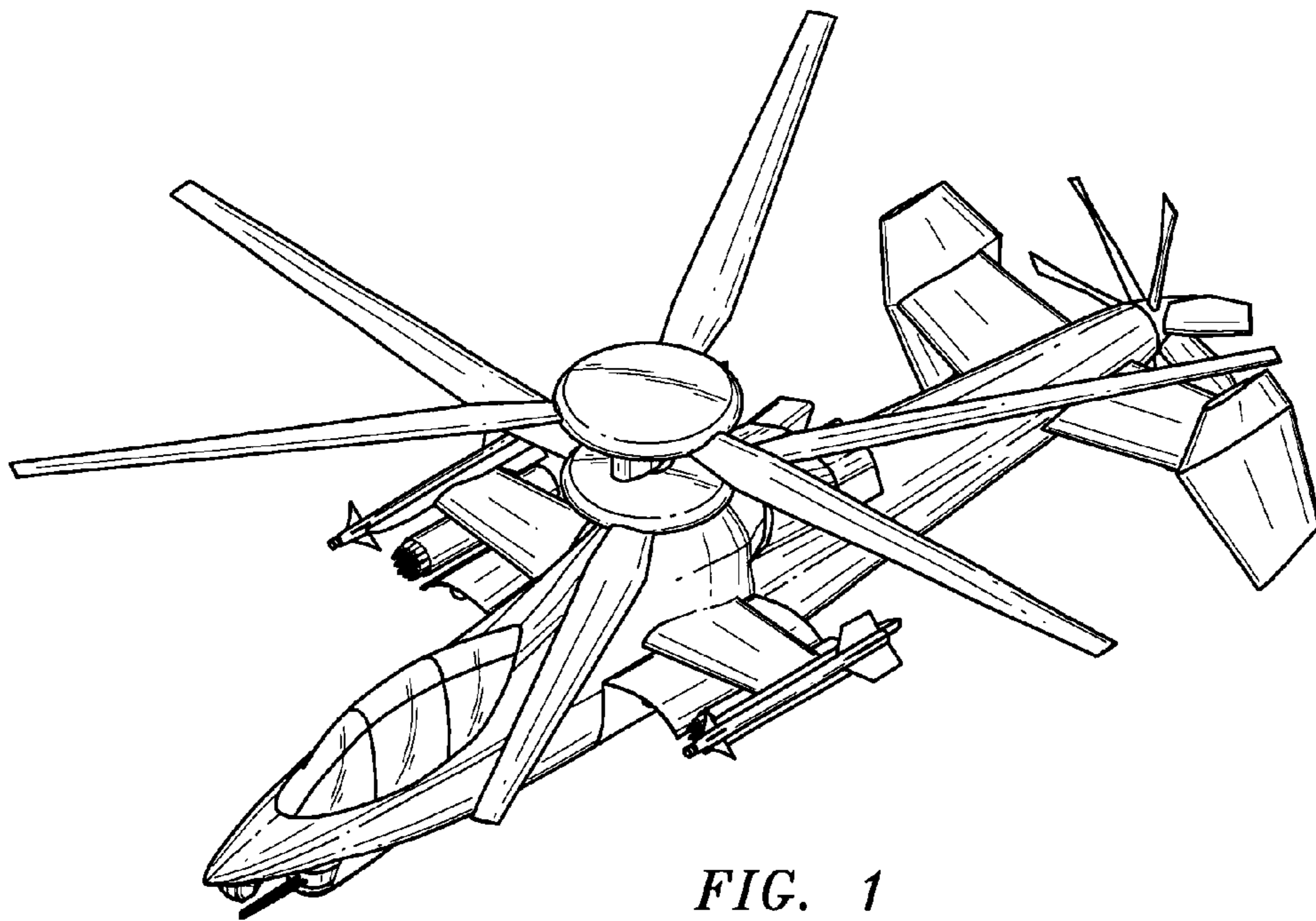

FIG. 1

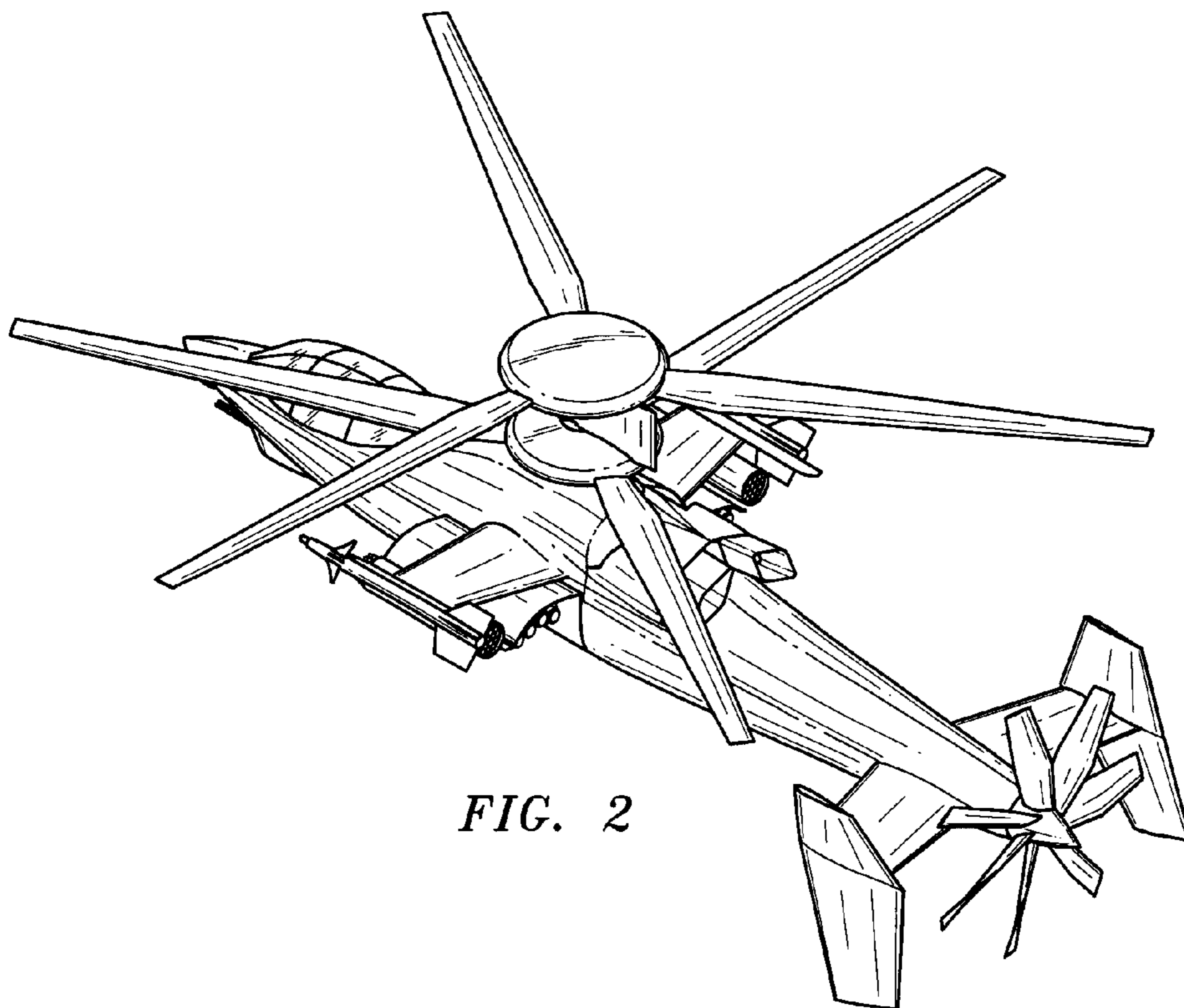

FIG. 2

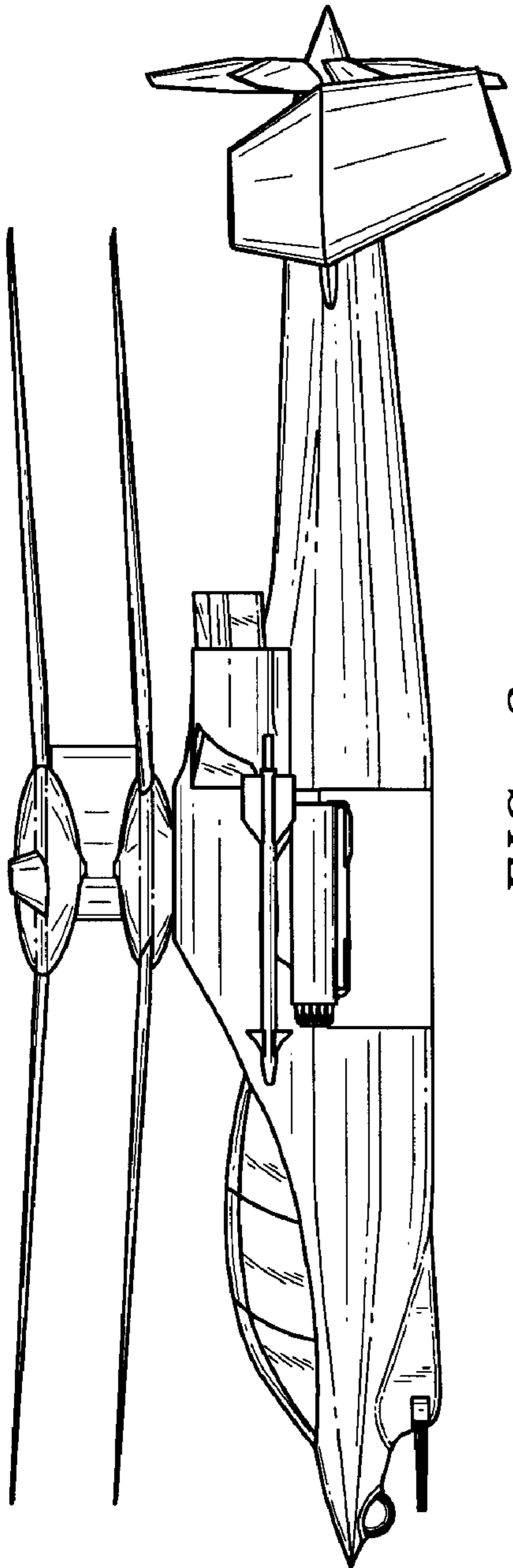

FIG. 3

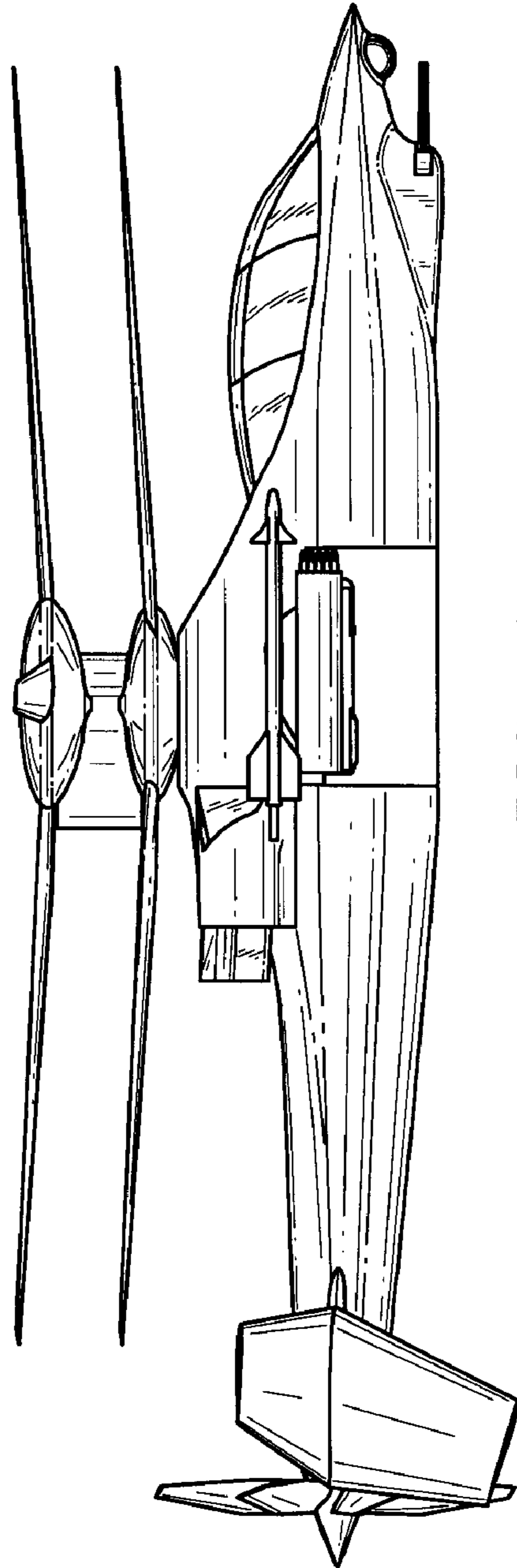

FIG. 4

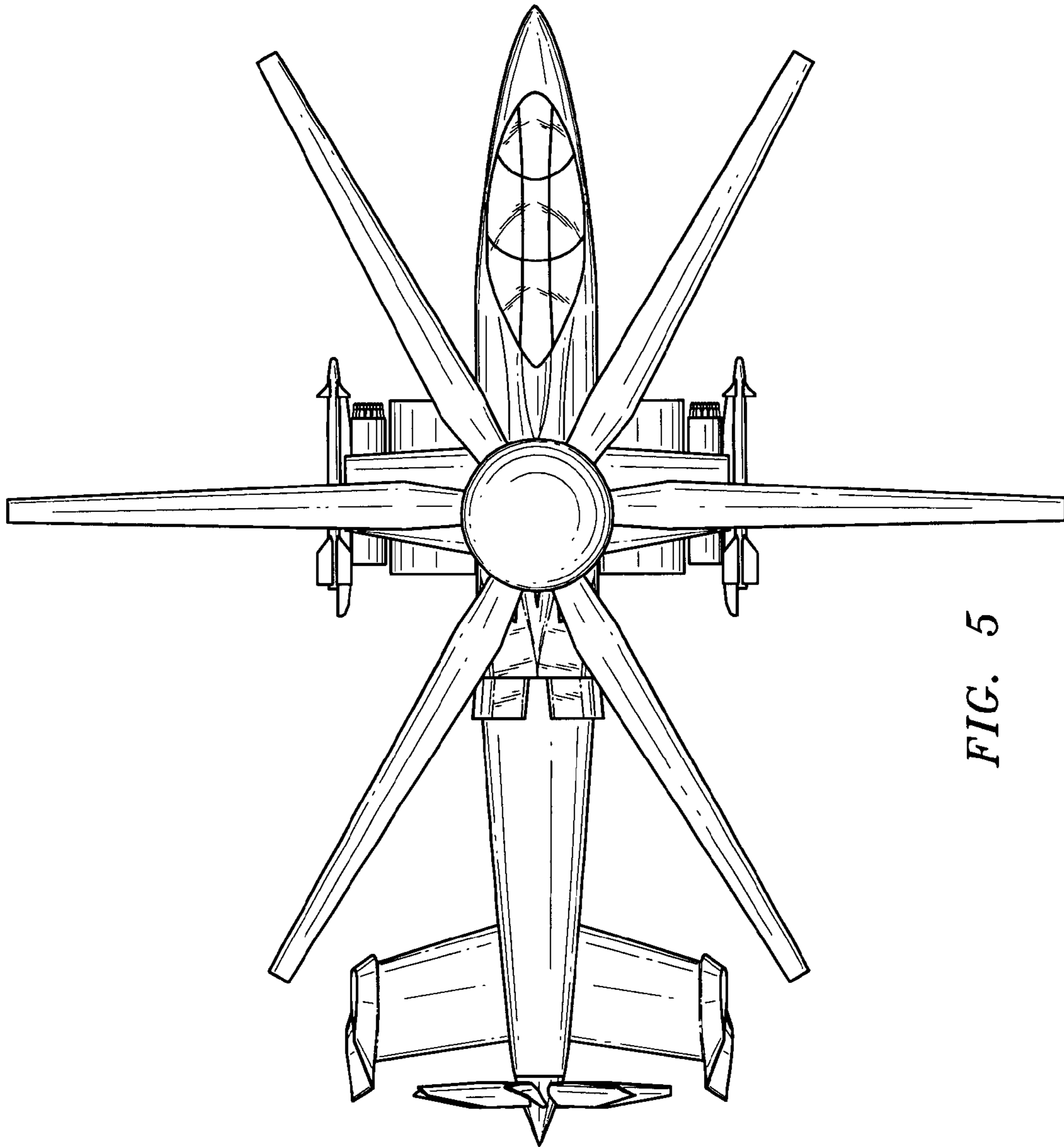

FIG. 5

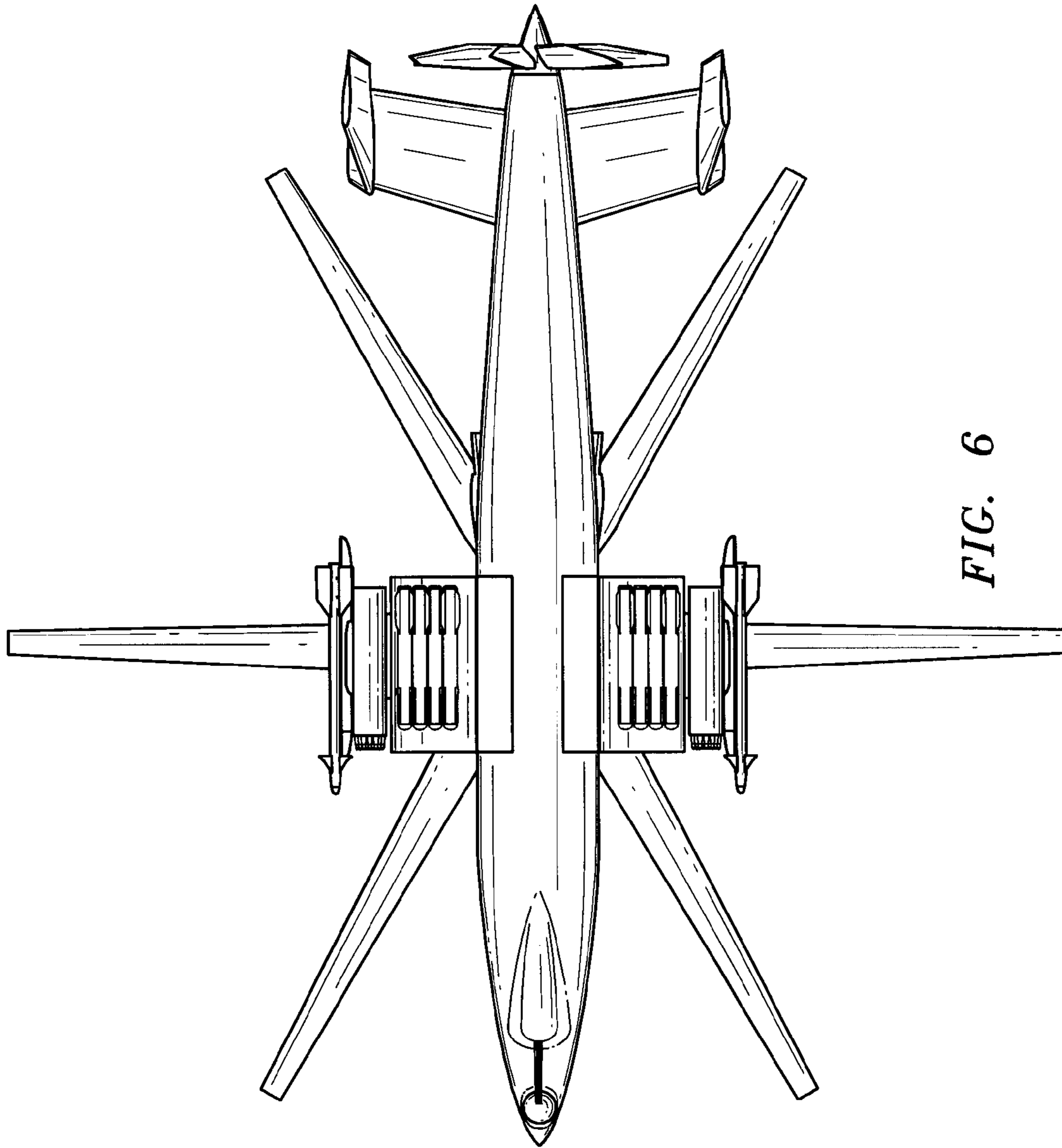

FIG. 6

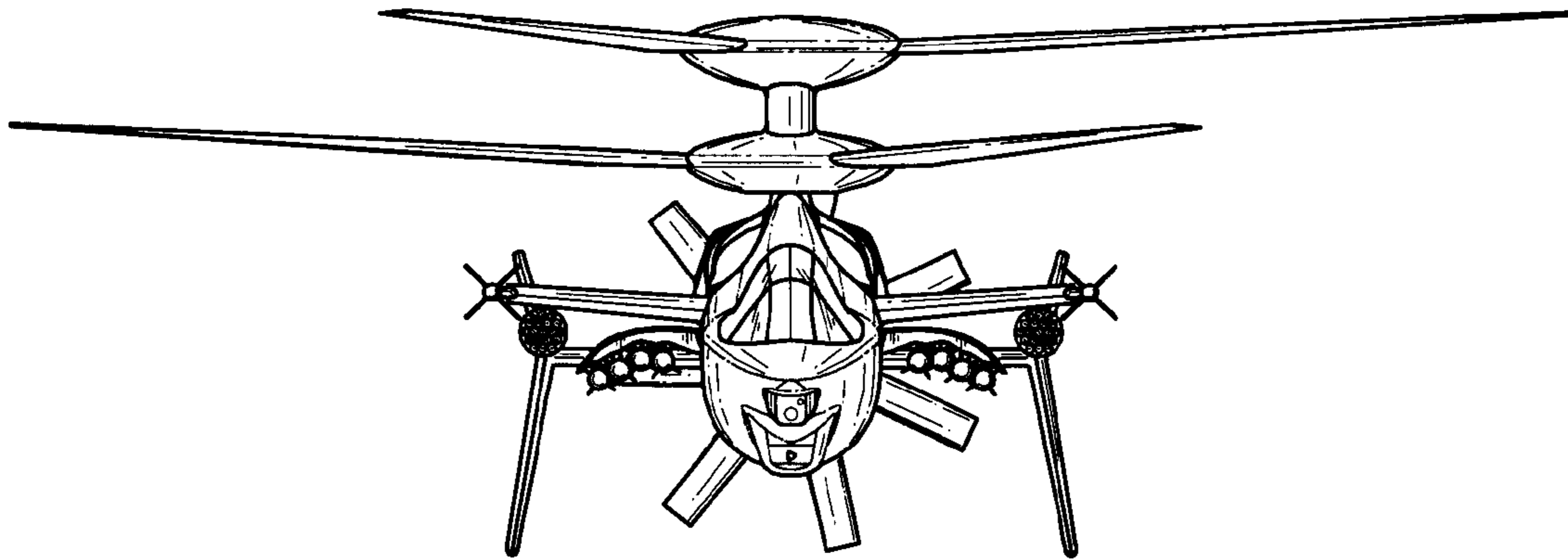

FIG. 7

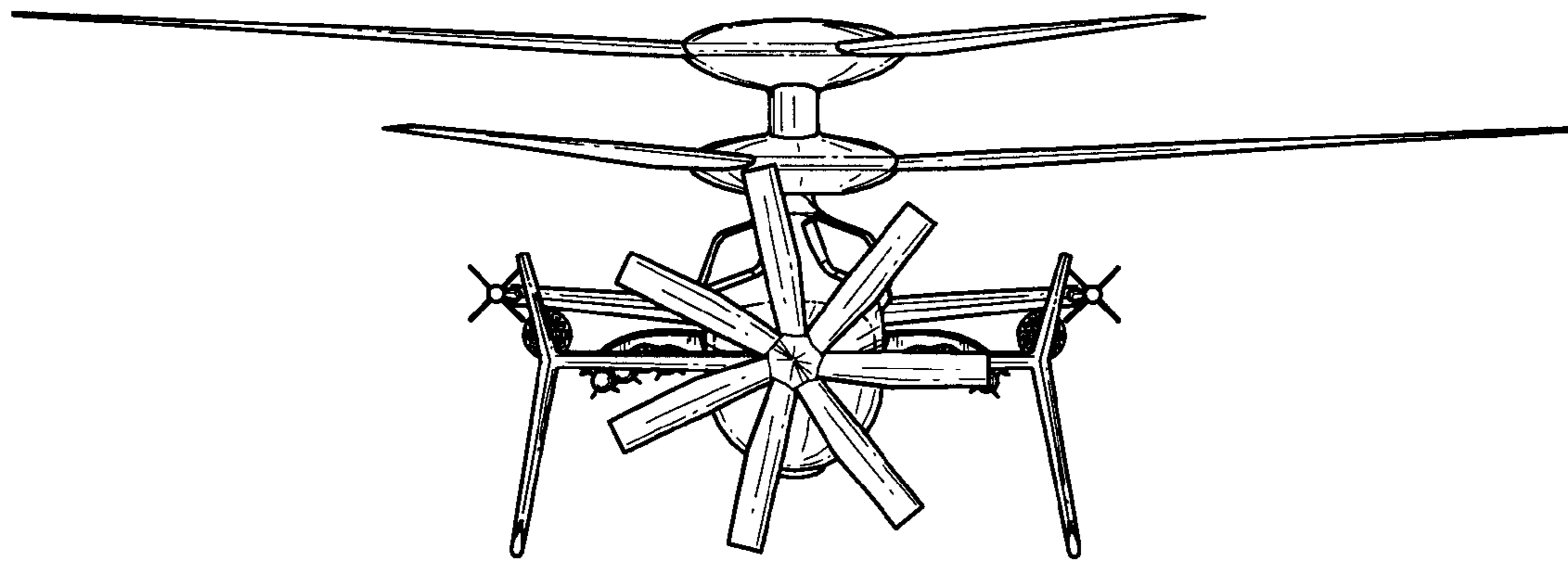

FIG. 8