



US00D526251S

(12) **United States Design Patent** (10) **Patent No.:** **US D526,251 S**  
**Shim et al.** (45) **Date of Patent:** **\*\* Aug. 8, 2006**

(54) **TRICYCLE FRAME**

(75) Inventors: **S. Scott Shim**, West Lafayette, IN (US); **Matthew C. Grossman**, West Lafayette, IN (US); **Ryan Lightbody**, Lafayette, IN (US)

(73) Assignee: **Purdue Research Foundation**, West Lafayette, IN (US)

(\*\*) Term: **14 Years**

(21) Appl. No.: **29/236,440**

(22) Filed: **Aug. 16, 2005**

(51) **LOC (8) Cl.** ..... **12-11**

(52) **U.S. Cl.** ..... **D12/111**

(58) **Field of Classification Search** ..... D12/111, D12/112, 117; 280/282, 281.1, 288.1-288.4, 280/220, 221, 267, 269

See application file for complete search history.

(56) **References Cited**

**U.S. PATENT DOCUMENTS**

3,799,565	A	3/1974	Burtis et al.	
3,937,486	A	2/1976	Weiters	
4,497,502	A	2/1985	Forbes et al.	
4,526,392	A *	7/1985	Berkstresser	280/282
4,789,173	A *	12/1988	Lofgren et al.	280/288.1
4,887,829	A	12/1989	Prince	
5,240,267	A	8/1993	Owsen	
5,480,172	A	1/1996	James	
D369,330	S *	4/1996	Hill et al.	D12/111
5,769,441	A	6/1998	Namngani	
D430,070	S	8/2000	Kciuk	
6,817,617	B1	11/2004	Hayashi	
D503,662	S	4/2005	Tiyawatchalapong	
2002/0163163	A1	11/2002	Shapiro	

**OTHER PUBLICATIONS**

Access Center Spoke Shop, Action Top End Eliminator™, [online], © 2000, [retrieved on Nov. 30, 2005]. Retrieved from the Internet: <[http://www.spokeshop.org/top\\_end\\_eliminator\\_racing\\_chair.htm](http://www.spokeshop.org/top_end_eliminator_racing_chair.htm)> (1 pg).

Invacare® Top End® Eliminator™ OSR Racing Chair, [online], © 2005, [retrieved on Nov. 30, 2005]. Retrieved from the Internet: [http://www.invacare.com/product\\_files/G2001\\_192B.pdf](http://www.invacare.com/product_files/G2001_192B.pdf) (2 pgs).

\* cited by examiner

*Primary Examiner*—Alan P. Douglas

*Assistant Examiner*—Linda Brooks

(74) *Attorney, Agent, or Firm*—William F. Bahret

(57) **CLAIM**

The ornamental design for a tricycle frame, as shown and described.

**DESCRIPTION**

FIG. 1 is a left, rear perspective view of a tricycle frame showing our new design.

FIG. 2 is a left side elevation view of the tricycle frame of FIG. 1.

FIG. 3 is a right side elevation view thereof.

FIG. 4 is a top plan view thereof.

FIG. 5 is a bottom plan view thereof.

FIG. 6 is a front elevation view thereof.

FIG. 7 is a rear elevation view thereof.

FIG. 8 is a left, rear perspective view of another embodiment of our new design including a rear tire set.

FIG. 9 is a left side elevation view of the tricycle frame and rear tire set of FIG. 8.

FIG. 10 is a right side elevation view thereof.

FIG. 11 is a top plan view thereof.

FIG. 12 is a bottom plan view thereof.

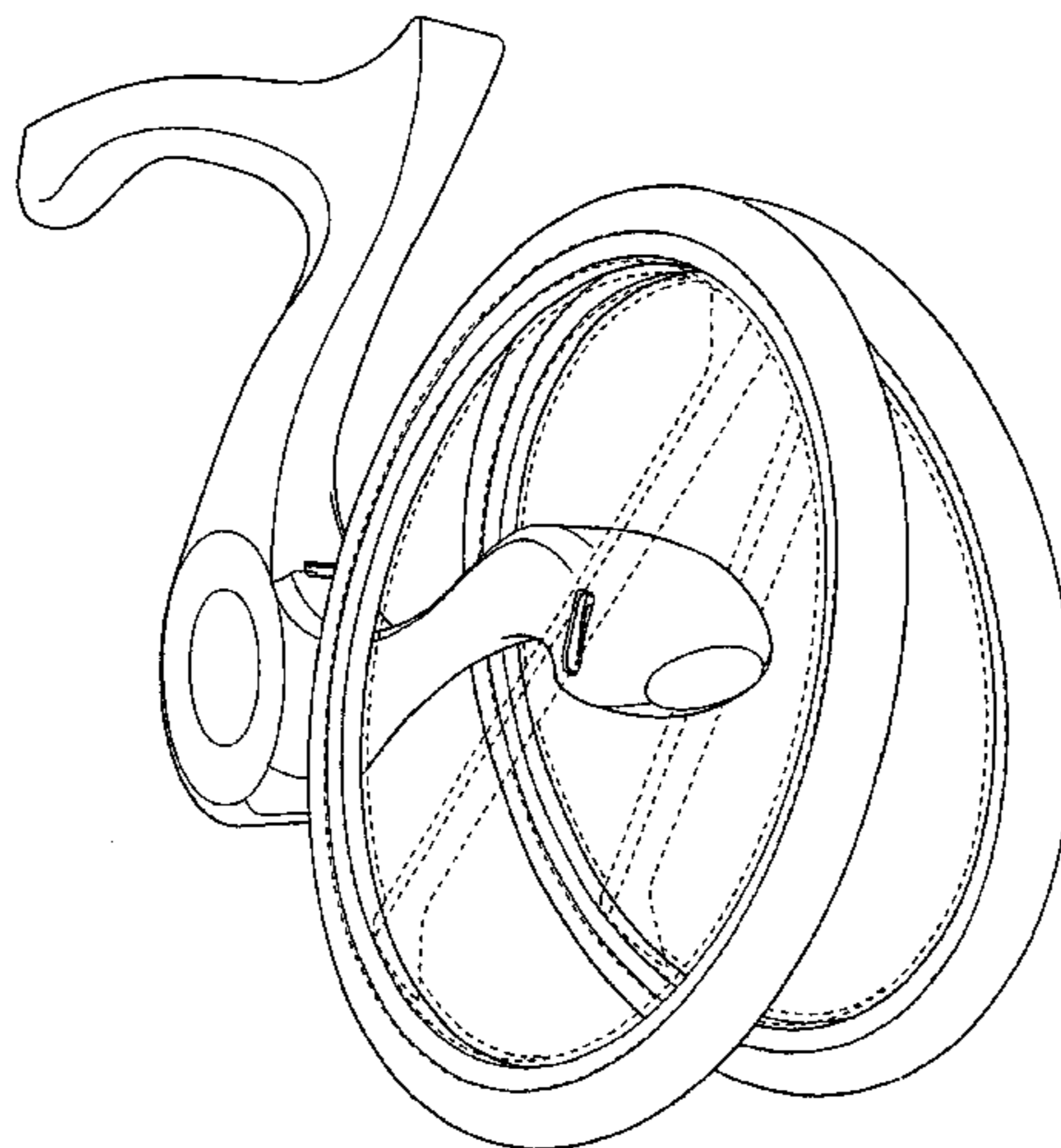
FIG. 13 is a front elevation view thereof; and,

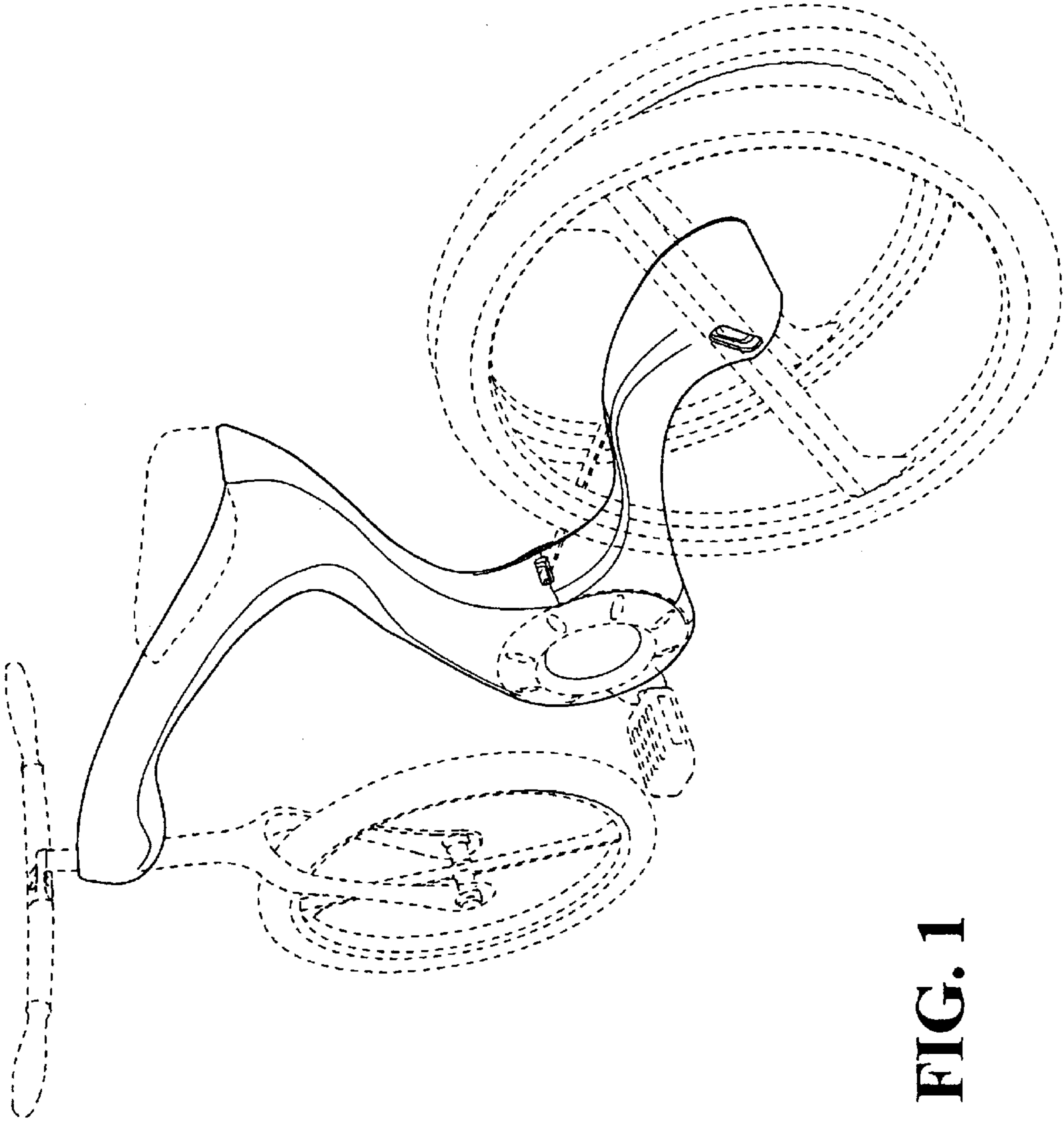
FIG. 14 is a rear elevation view thereof.

The wheels, forks, handlebars and other tricycle parts shown in broken lines in FIGS. 1-7 illustrate environmental structure and form no part of the claimed design.

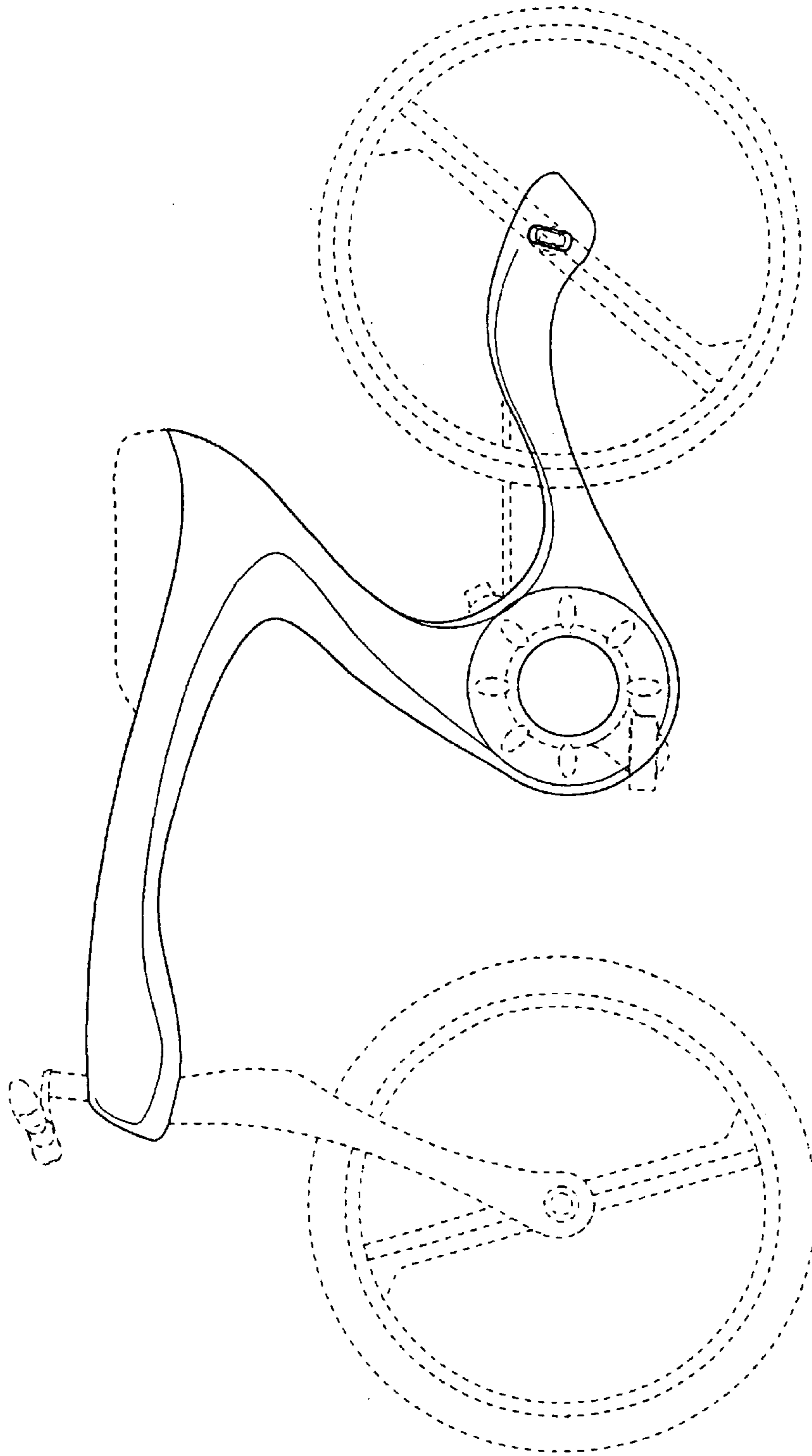
The wheels shown in broken lines in FIGS. 8-14 illustrate environmental structure and form no part of the claimed design.

**1 Claim, 10 Drawing Sheets**

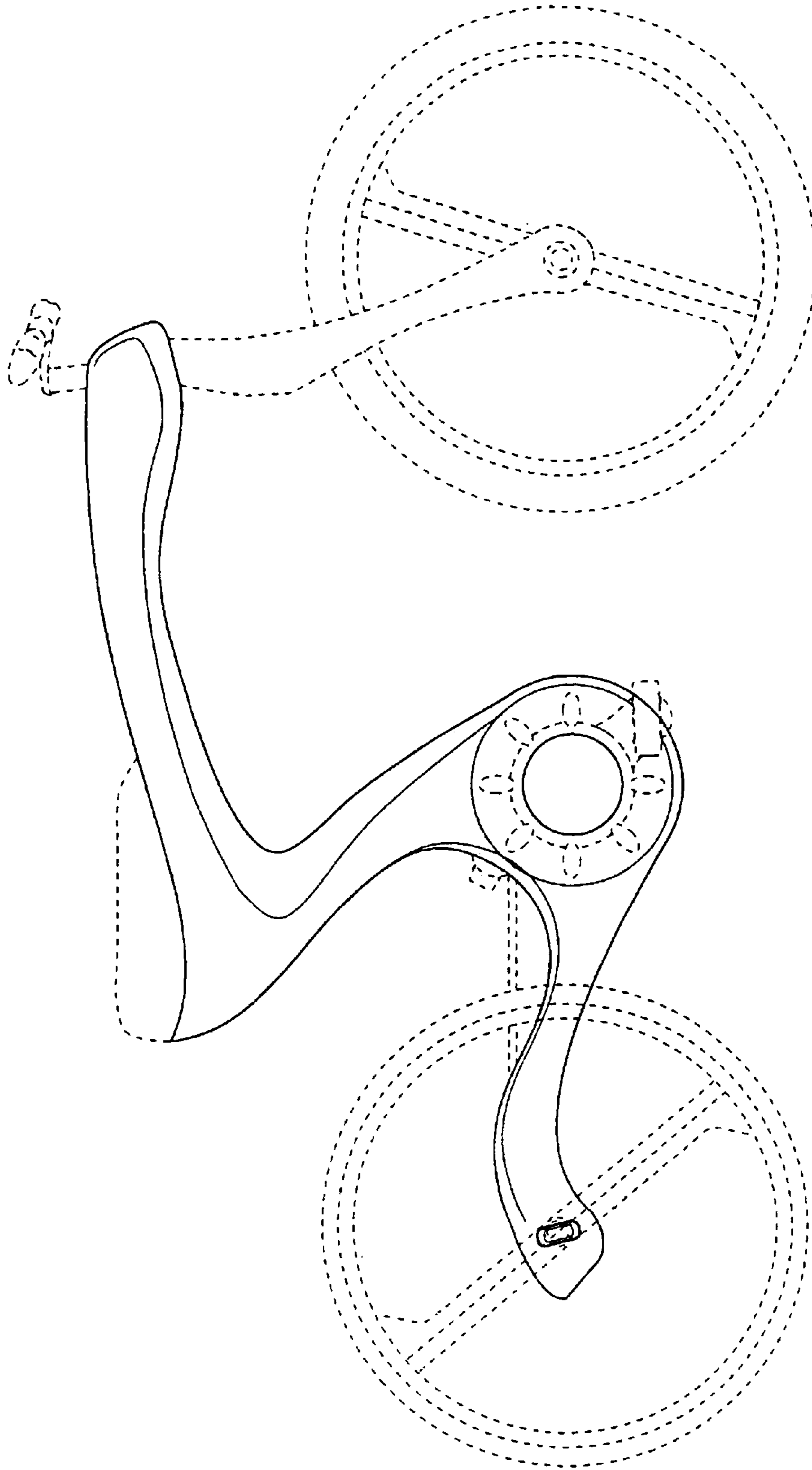




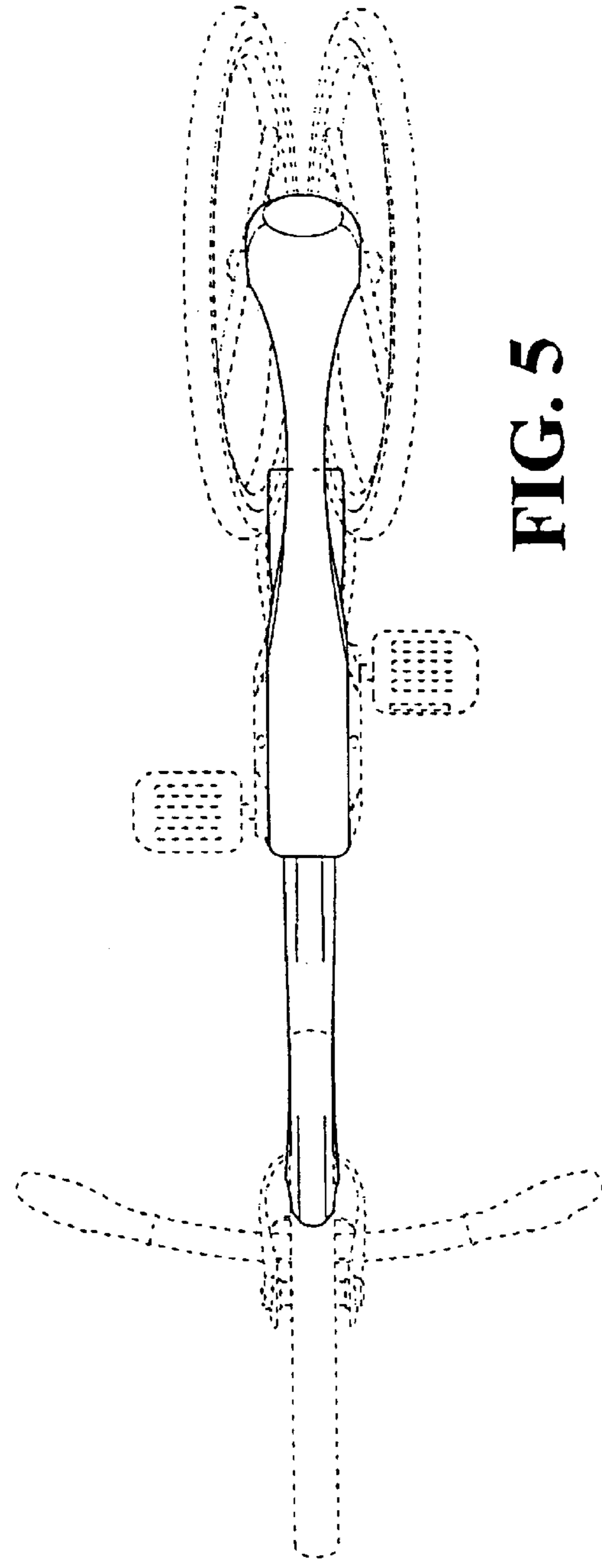
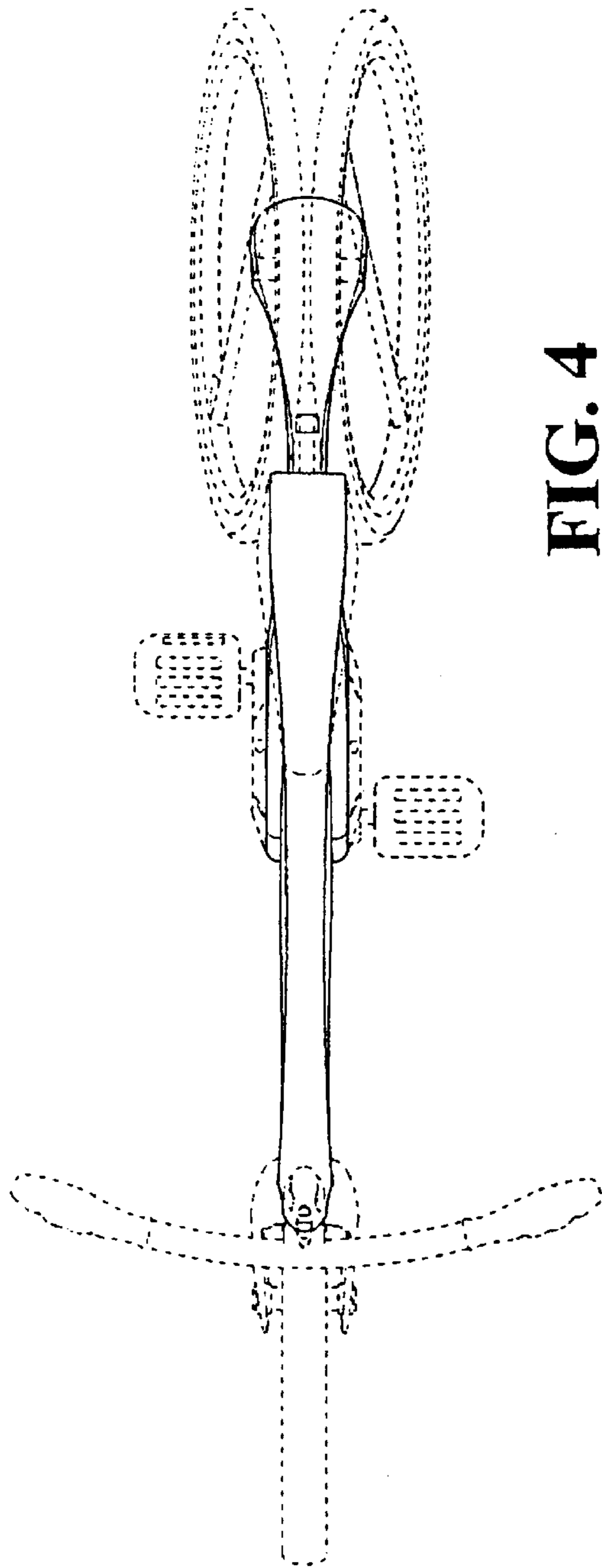
**FIG. 1**



**FIG. 2**



**FIG. 3**



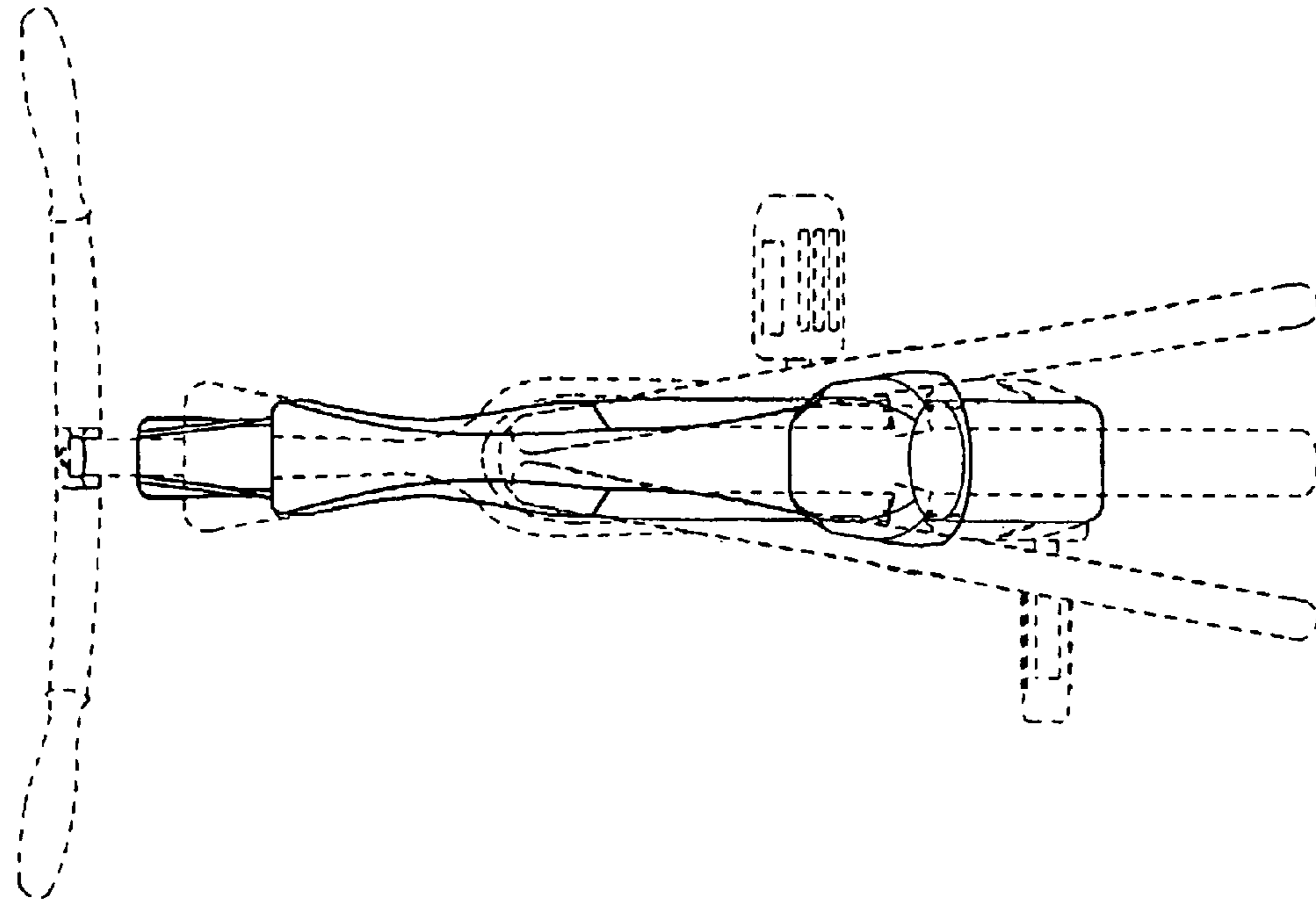


FIG. 6

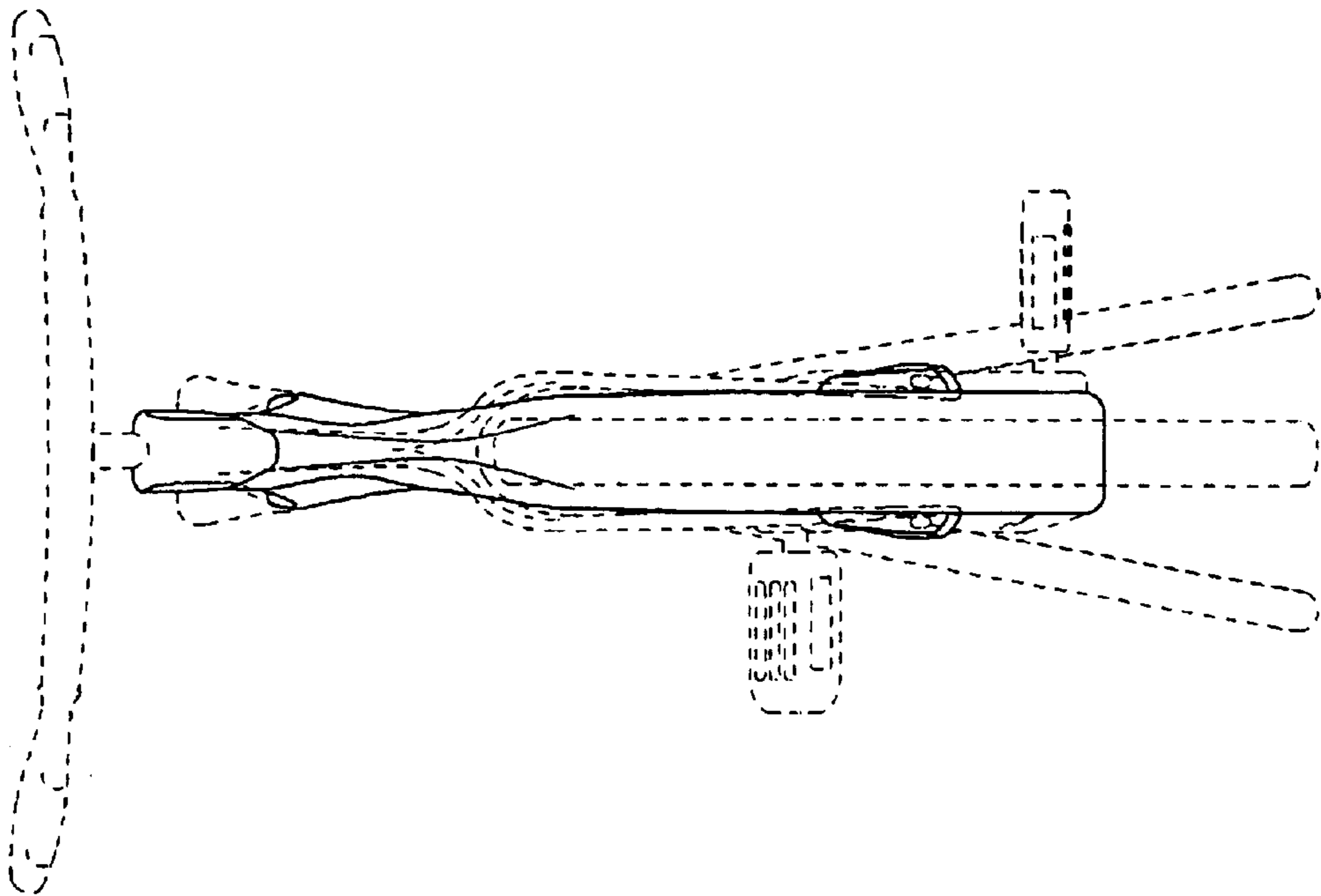
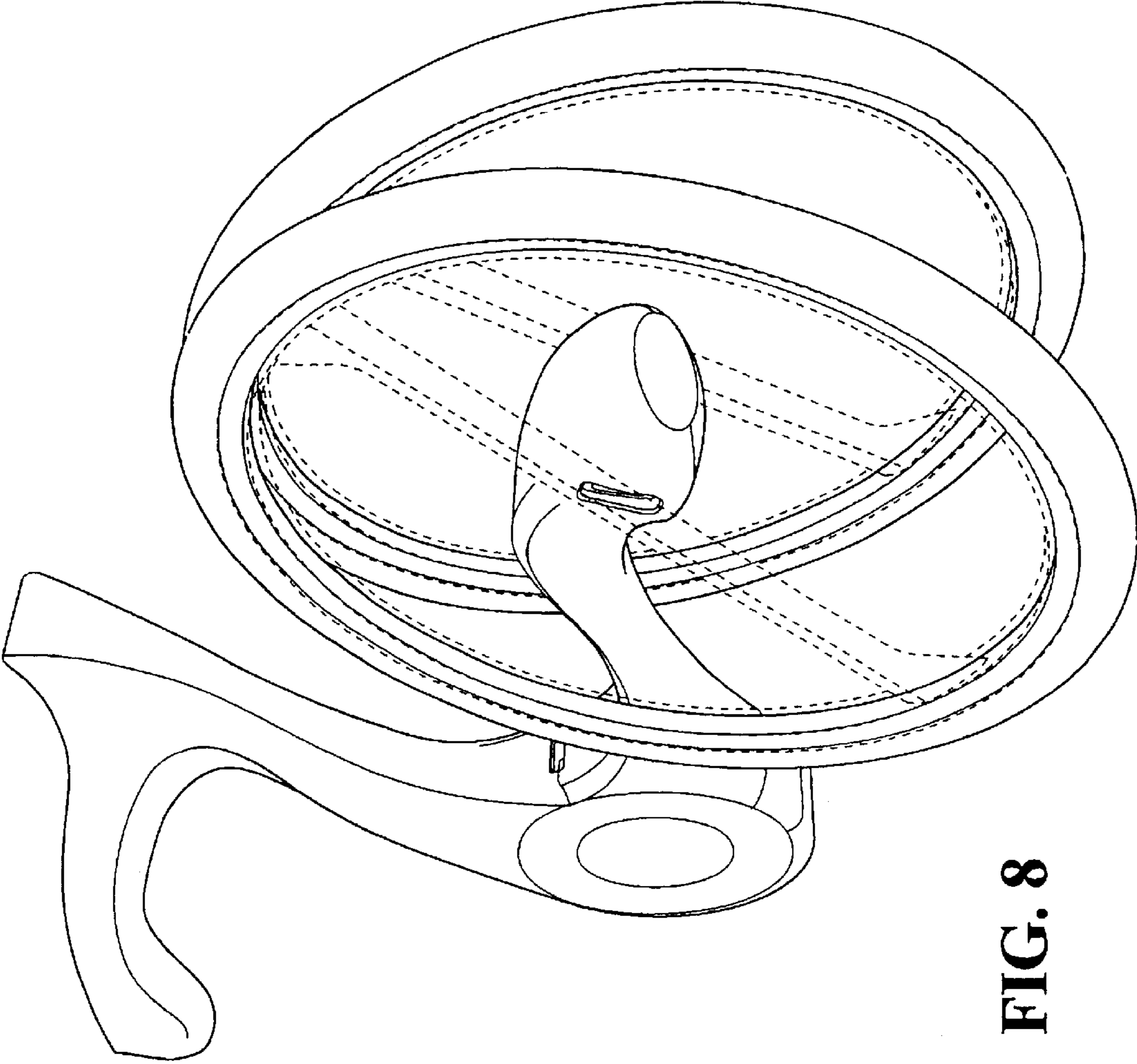
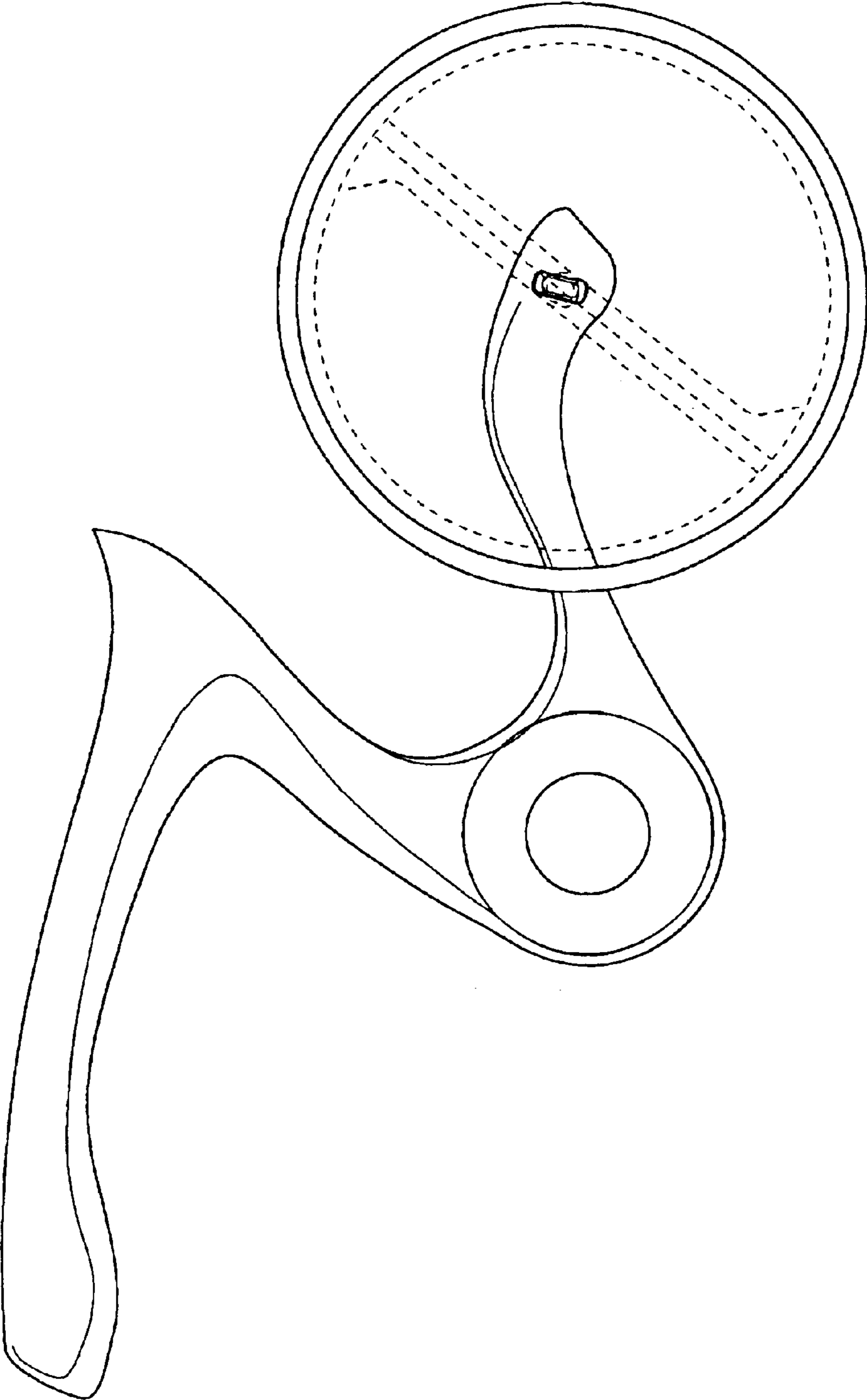


FIG. 7



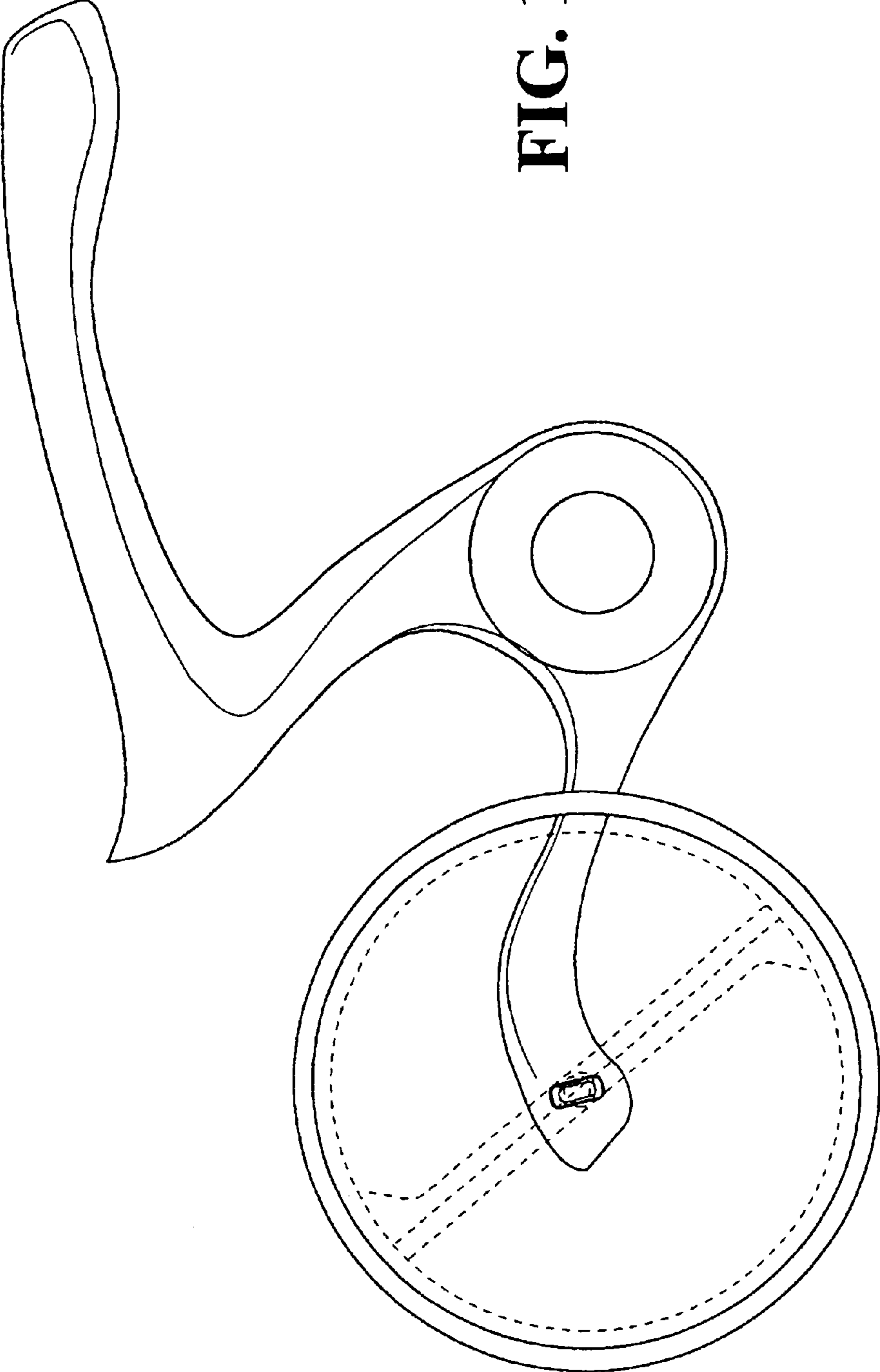
**FIG. 8**

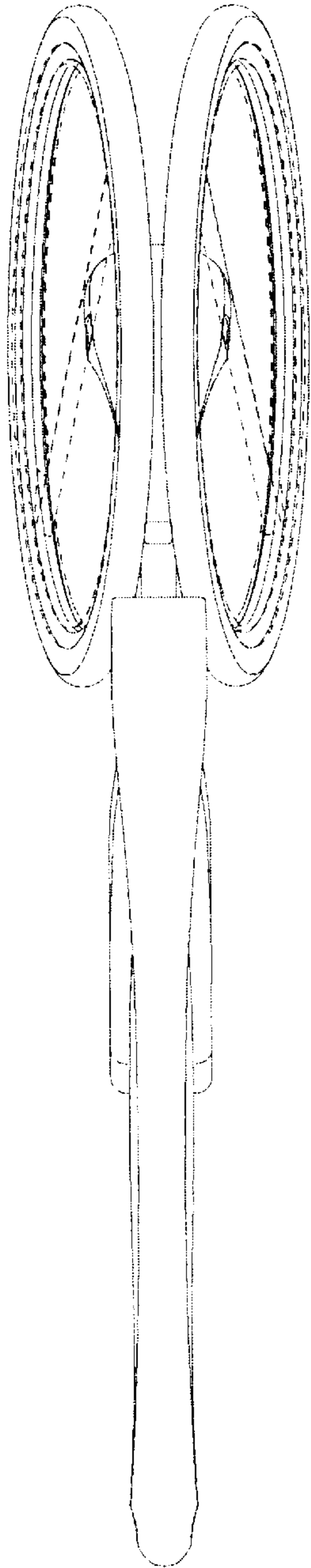


**FIG. 9**

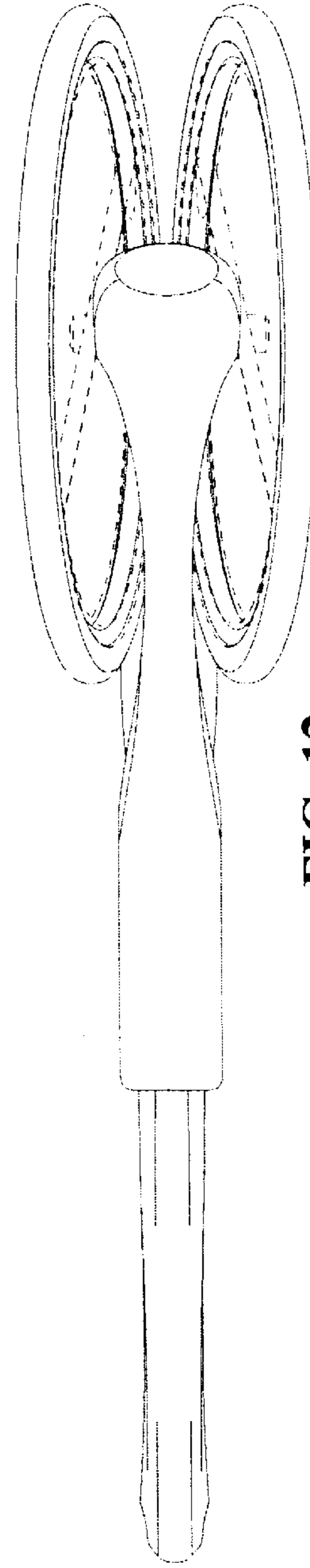


FIG. 10

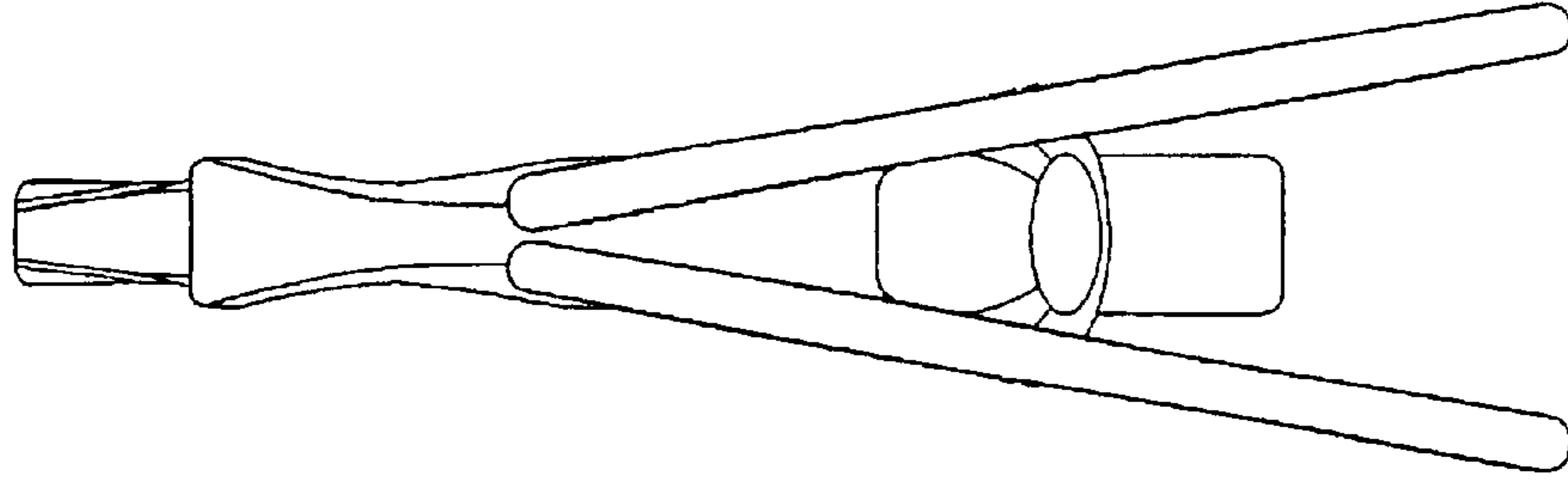




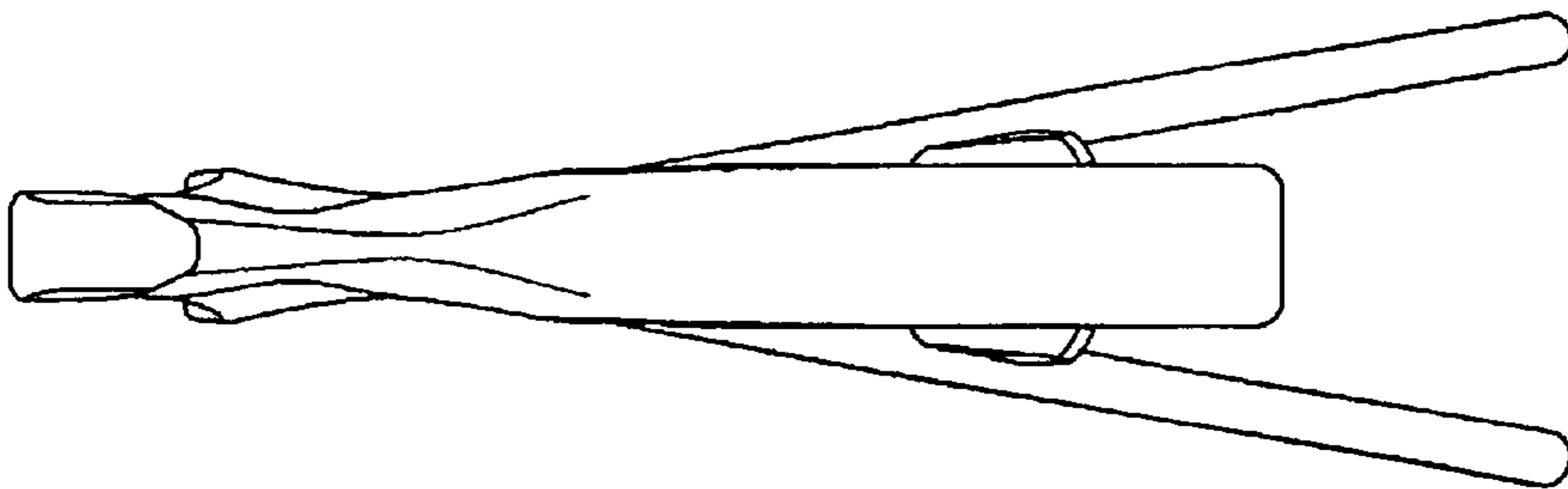
**FIG. 11**



**FIG. 12**



**FIG. 14**



**FIG. 13**