



US00D526062S

(12) **United States Design Patent**  
**Harn et al.**

(10) **Patent No.:** **US D526,062 S**

(45) **Date of Patent:** **\*\* Aug. 1, 2006**

(54) **ARTIFICIAL JOINT**

(75) Inventors: **Chuen-Sen Harn**, Xin-Zhuang (TW);  
**Rueng-Jie Zhen**, Xin-Zhuang (TW)

(73) Assignee: **Chang-Yu Mechanical System Ltd.**,  
Taipei (TW)

(\*\*) Term: **14 Years**

(21) Appl. No.: **29/232,020**

(22) Filed: **Jun. 15, 2005**

(30) **Foreign Application Priority Data**

Jan. 13, 2005 (TW) ..... 94300202

(51) **LOC (8) Cl.** ..... **24-03**

(52) **U.S. Cl.** ..... **D24/155**

(58) **Field of Classification Search** ..... D24/155;  
606/61, 72, 74; 623/17.16, 17.17, 11.11,  
623/11, 16, 35, 32, 27, 20, 30, 37, 39, 44,  
623/45, 43, 38

See application file for complete search history.

(56) **References Cited**

**U.S. PATENT DOCUMENTS**

5,545,232 A \* 8/1996 Van de Veen ..... 623/39  
D383,542 S \* 9/1997 Wellershaus et al. .... D24/155  
5,728,173 A \* 3/1998 Chen ..... 623/44  
D402,368 S \* 12/1998 Holzapfel ..... D24/155  
6,106,560 A \* 8/2000 Boender ..... 623/44

D439,339 S \* 3/2001 Sawatzki ..... D24/155  
D446,304 S \* 8/2001 Sawatzki et al. .... D24/155  
6,322,594 B1 \* 11/2001 Boiten et al. .... 623/27  
6,558,430 B1 \* 5/2003 Nakaya et al. .... 623/17.16  
6,743,255 B1 \* 6/2004 Ferree ..... 623/17.11  
2002/0045946 A1 \* 4/2002 Habecker ..... 623/17.11  
2004/0059433 A1 \* 3/2004 Slemker et al. .... 623/17.16  
2005/0038523 A1 \* 2/2005 Cheng ..... 623/17.16  
2005/0149203 A1 \* 7/2005 Andrysek et al. .... 623/17.11  
2005/0154473 A1 \* 7/2005 Bassett ..... 623/17.16  
2005/0203639 A1 \* 9/2005 Wild ..... 623/17.16  
2005/0234562 A1 \* 10/2005 Okuda et al. .... 623/17.16

\* cited by examiner

*Primary Examiner*—Charles A. Rademaker

(74) *Attorney, Agent, or Firm*—Rabin & Berdo, P.C.

(57) **CLAIM**

The ornamental design for artificial joint, as shown and described.

**DESCRIPTION**

FIG. 1 is a perspective view of artificial joint showing my new design;

FIG. 2 is a front elevational view thereof;

FIG. 3 is a rear elevational view thereof;

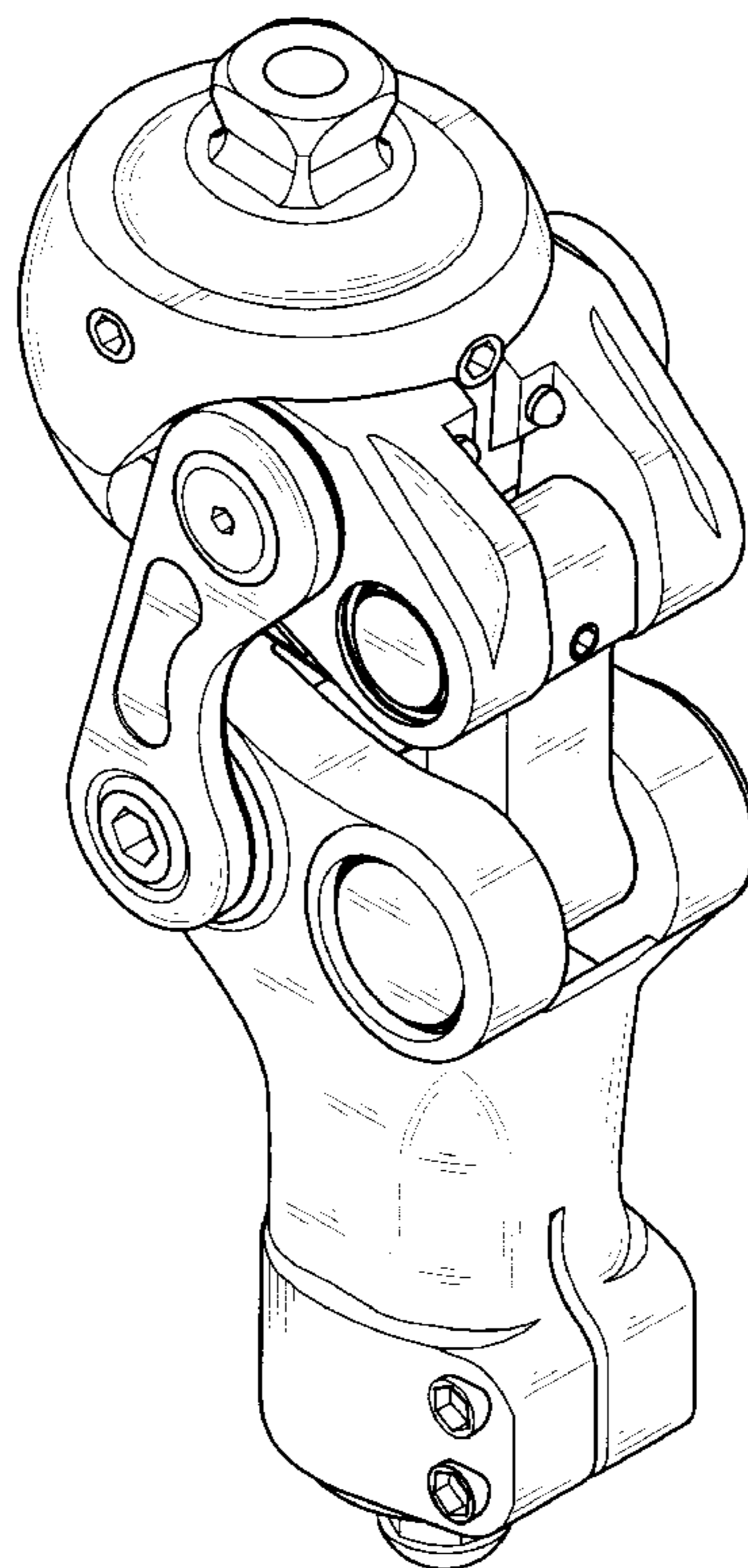
FIG. 4 is a left elevational view thereof;

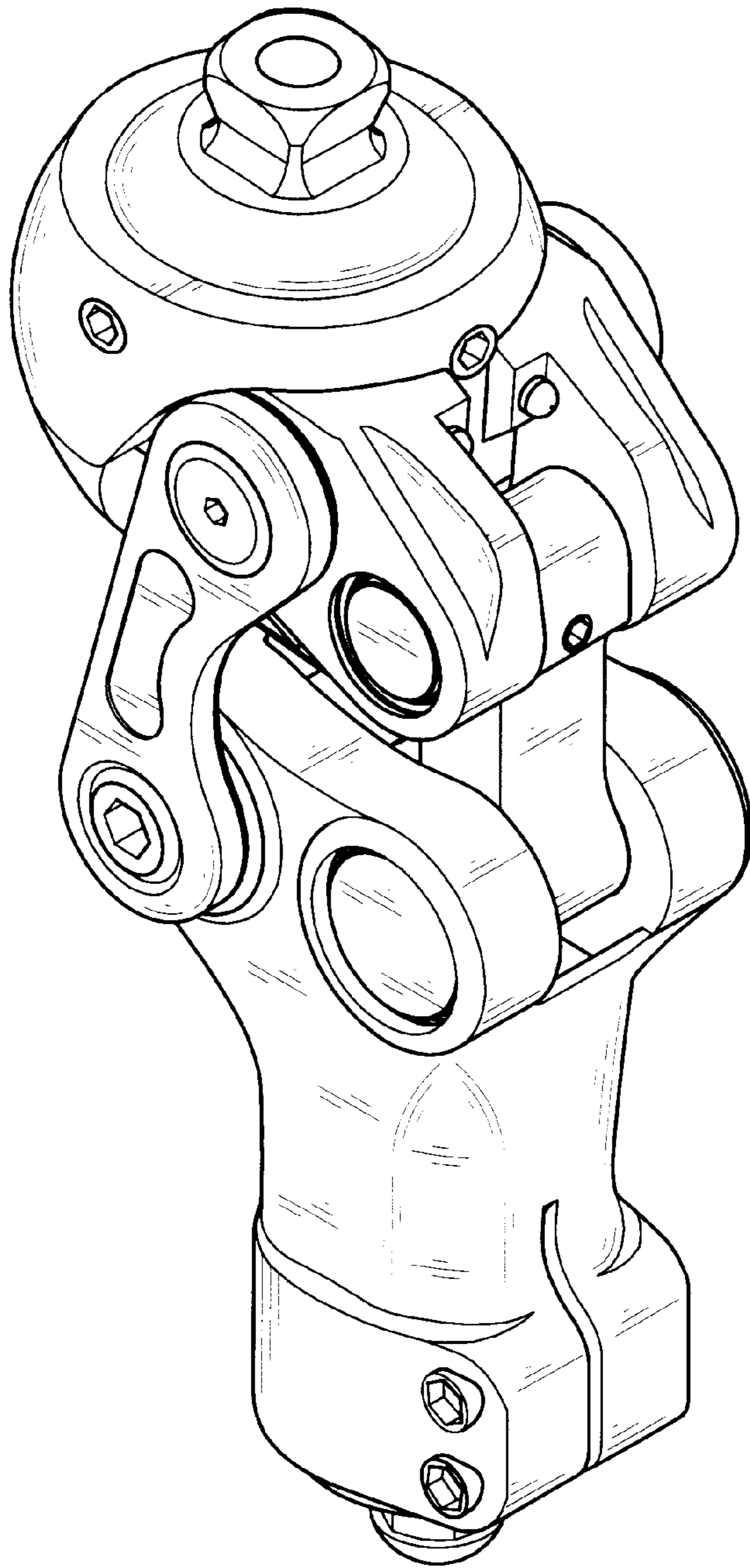
FIG. 5 is a right elevational view thereof;

FIG. 6 is a top view thereof; and,

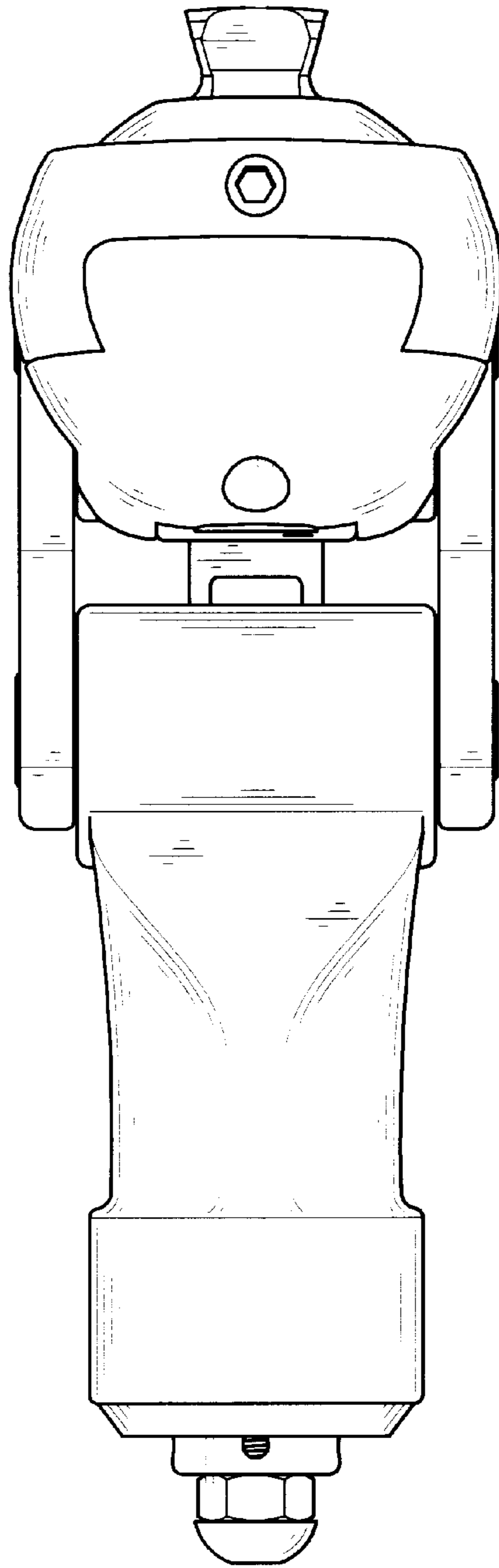
FIG. 7 is a bottom view.

**1 Claim, 7 Drawing Sheets**

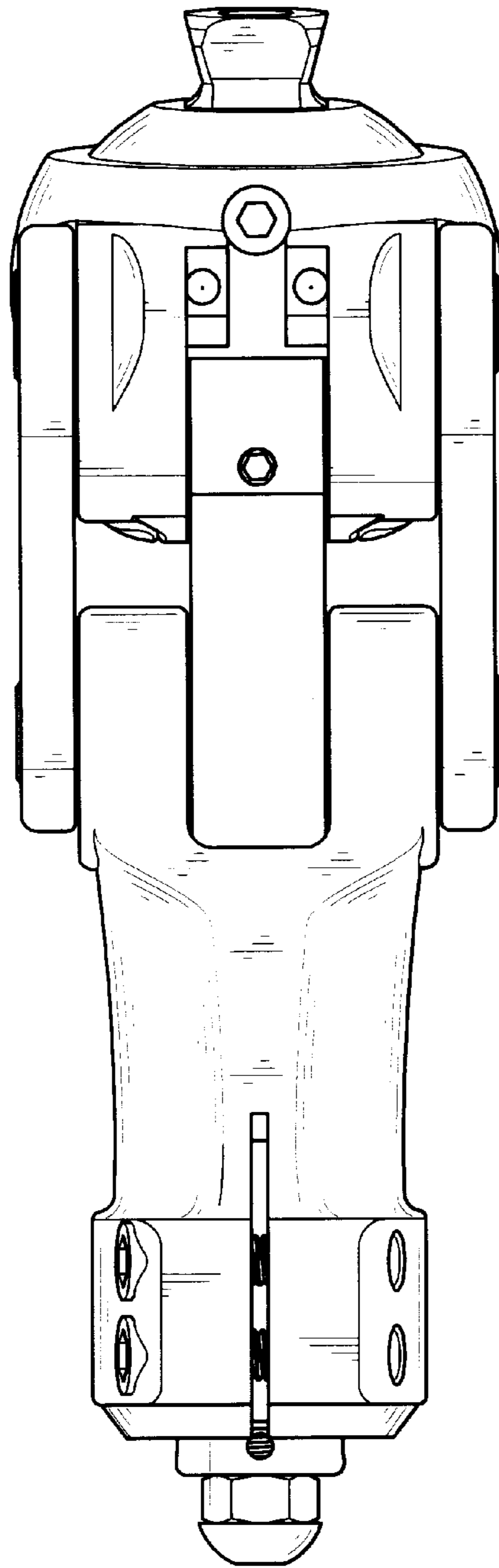




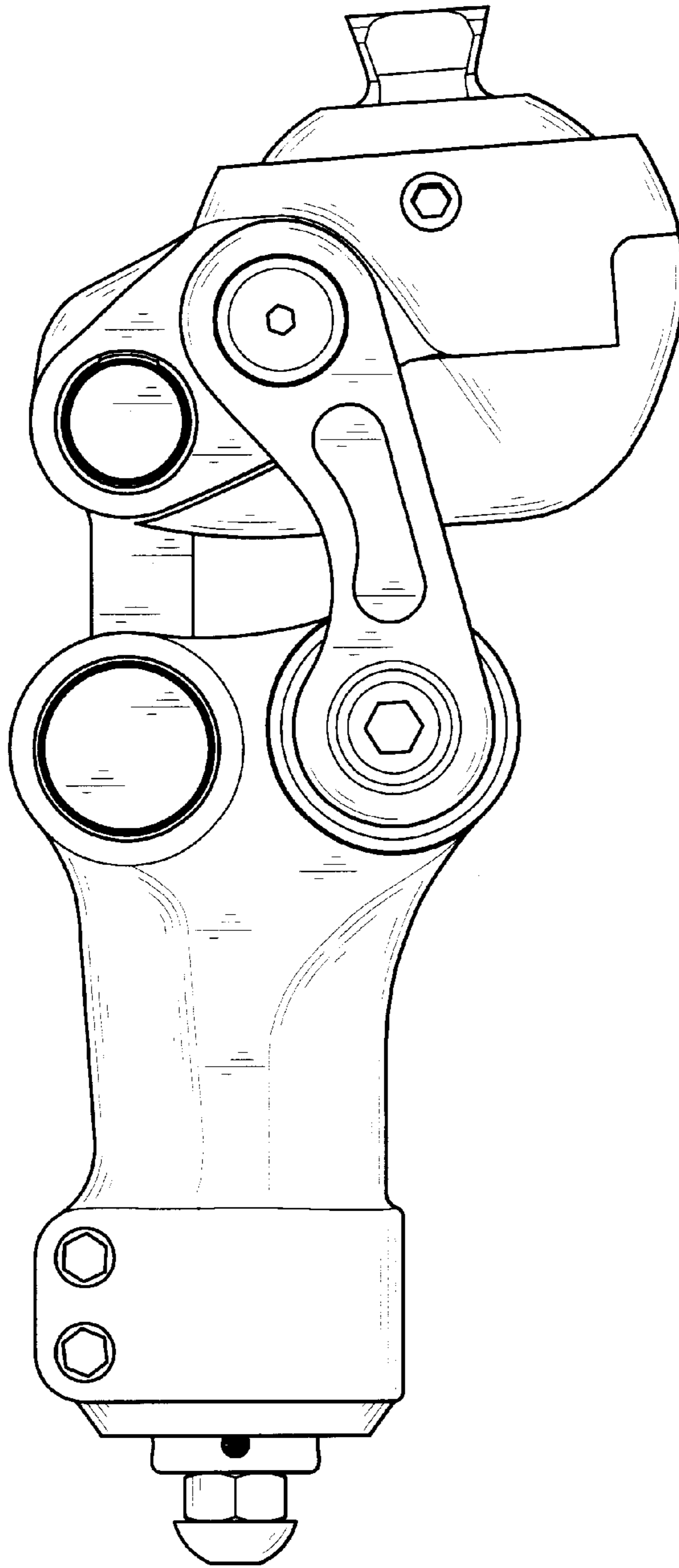
**FIG. 1**



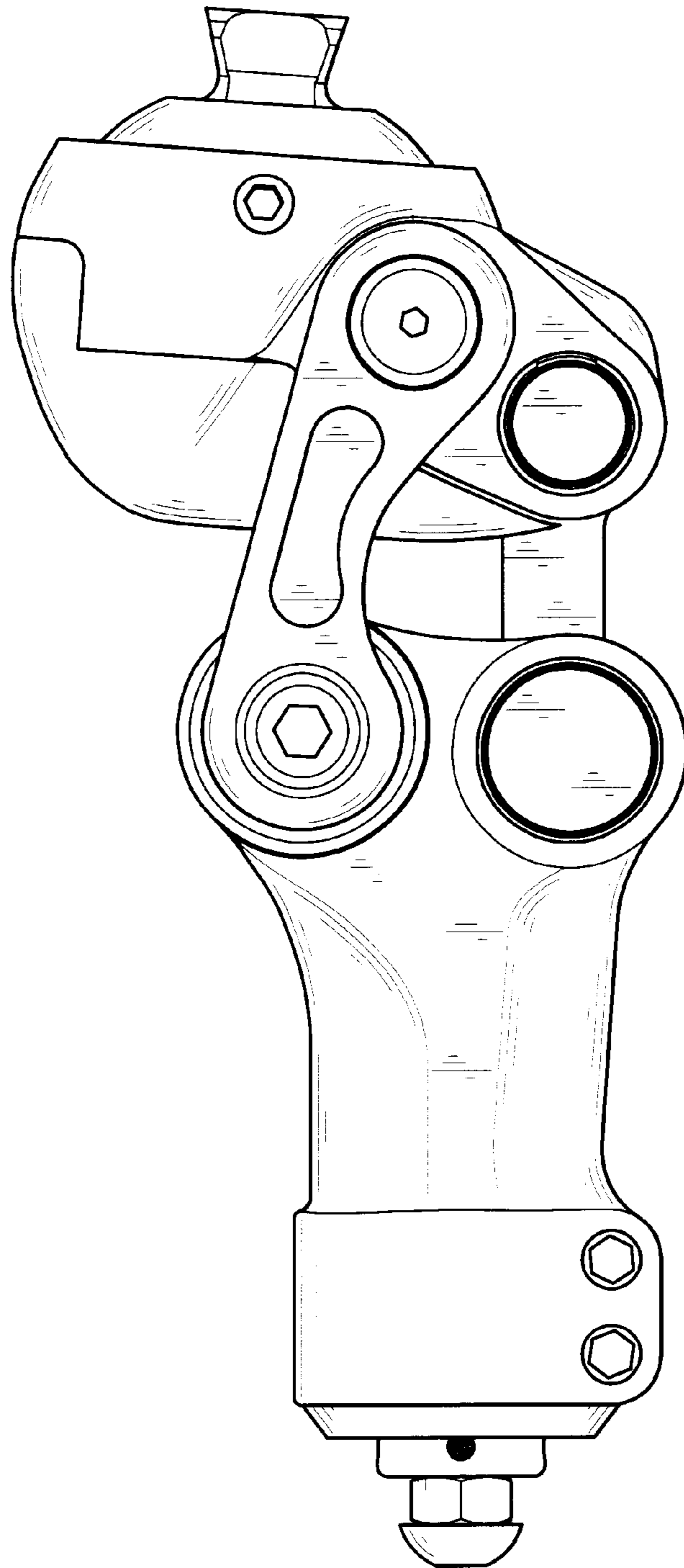
**FIG. 2**



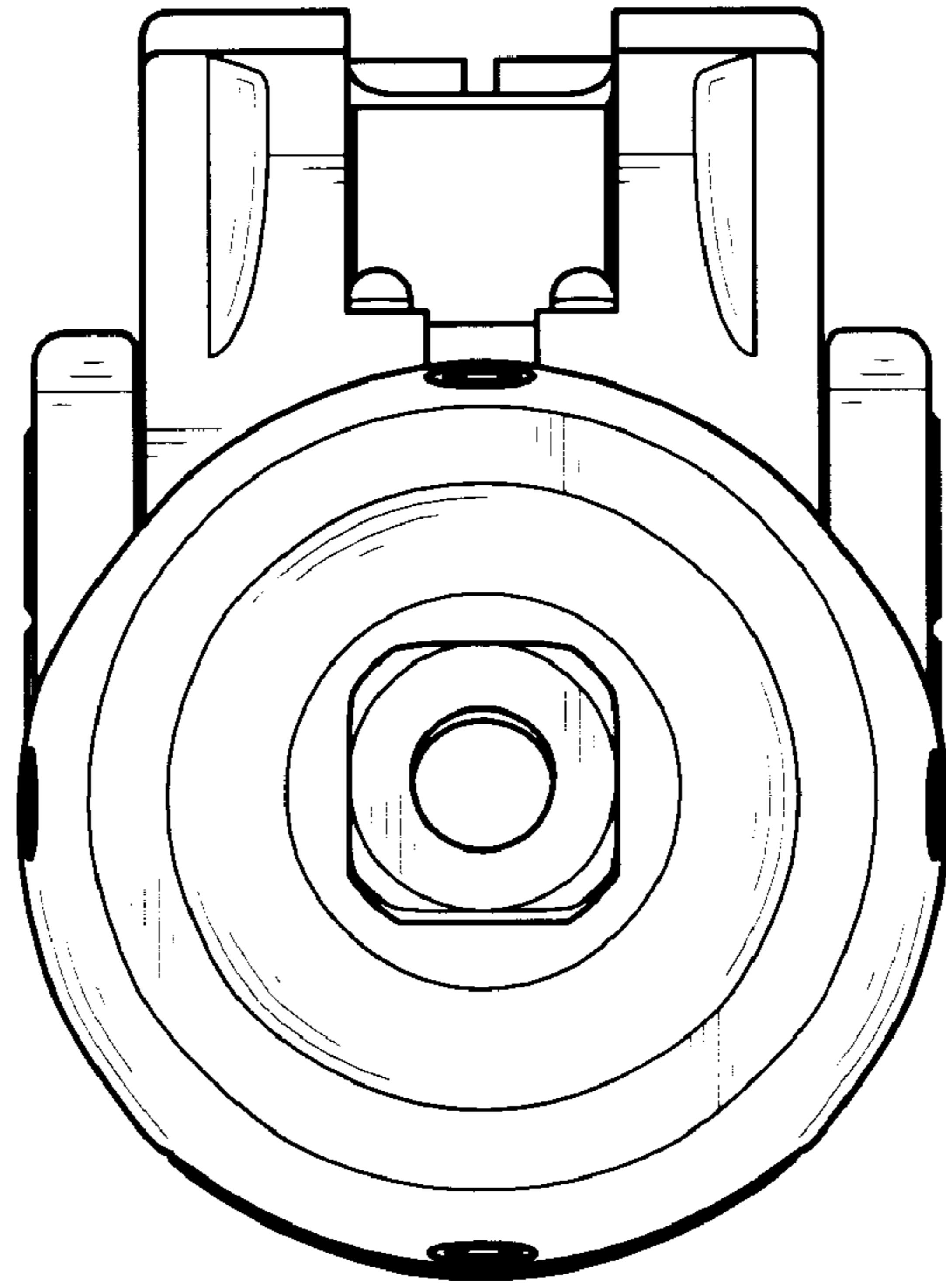
**FIG. 3**



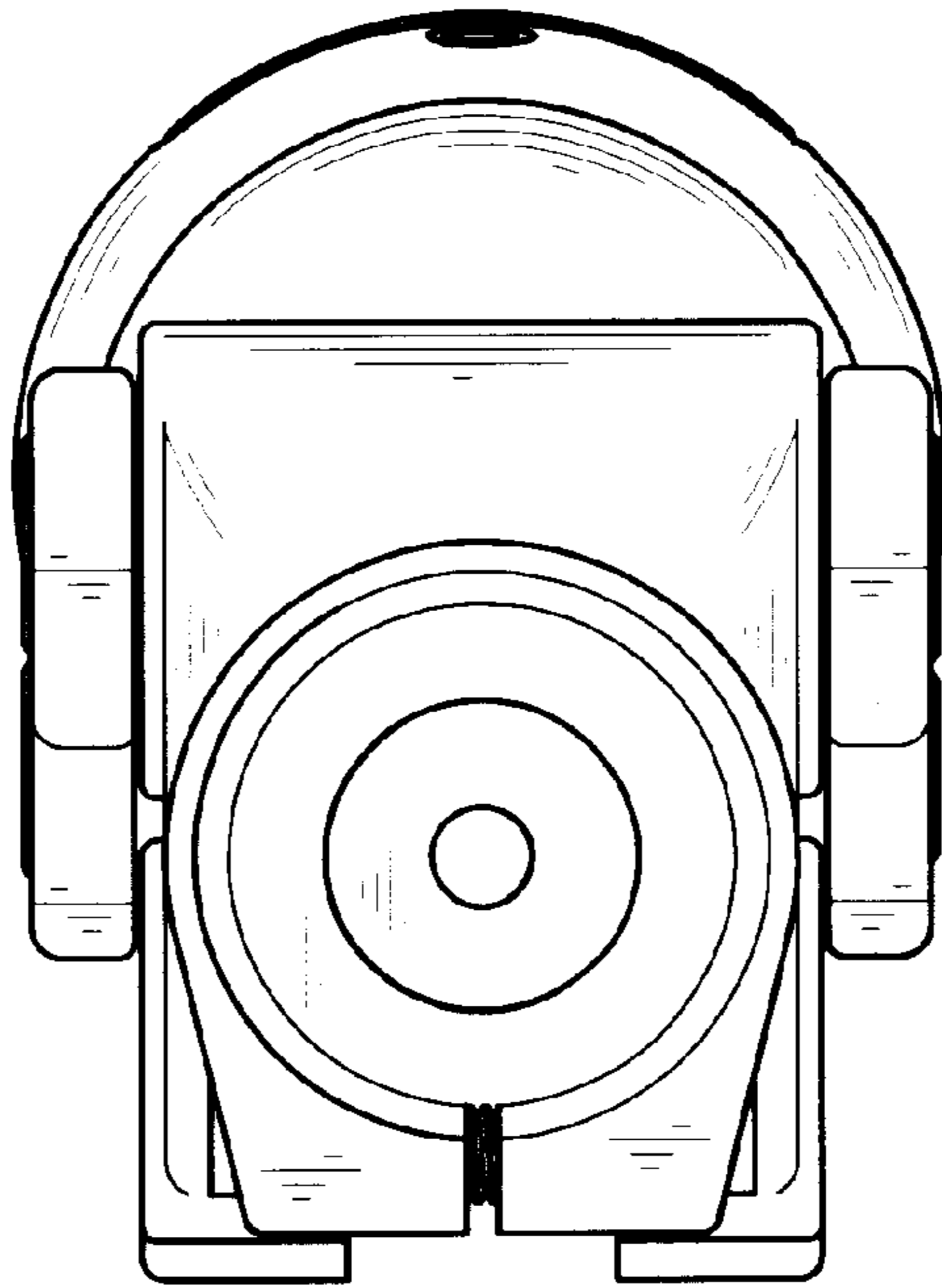
**FIG. 4**



**FIG. 5**



**FIG. 6**



**FIG. 7**