



US00D525991S

(12) **United States Design Patent**
Walters

(10) **Patent No.:** **US D525,991 S**

(45) **Date of Patent:** **** Aug. 1, 2006**

(54) **ENGINE COVER**

(75) Inventor: **Richard Walters**, Cedar Grove, WI (US)

(73) Assignee: **Briggs & Stratton Corporation**, Wauwatosa, WI (US)

(**) Term: **14 Years**

(21) Appl. No.: **29/208,607**

(22) Filed: **Jun. 30, 2004**

(51) **LOC (8) Cl.** **15-01**

(52) **U.S. Cl.** **D15/5**

(58) **Field of Classification Search** D15/1-5, D15/14-17, 149; D12/163-166; D13/112, D13/184, 199; D34/15; 56/320.1-320.2; 180/89.1, 89.12; 46/36, 78, 39, 249; 74/606 R; 123/50-51 BD, 65 R, 56, 70 R, 198, 195.3, 123/667, 50 A, 50 B, 50 R, 51 R, 51 A, 123/41.7, 198 E, 306, 308, 661, 432, 56 B, 123/56 BA, 657, 56 BC, 52 R, 41.66, 311, 123/198.5, 41.67, 195 C, 56 A, 150 BA
See application file for complete search history.

(56) **References Cited**

U.S. PATENT DOCUMENTS

D198,043 S 4/1964 Stevens
4,233,043 A 11/1980 Catterson

(Continued)

OTHER PUBLICATIONS

Kawasaki, Four-Cycle Engines, Kawasaki FJ180V, website, http://www.kawpowr.com/4cycle/fj180v_specs.html, 1 page, Feb. 2, 2005.

Kawasaki, Four-Cycle Engines, Kawasaki FC290v, website, http://www.kawpowr.com/4cycle/fc290v_specs.html, 1 page, Feb. 2, 2005.

Kawasaki, Four-Cycle Engines, Kawasaki FH721D, website, http://www.kawpowr.com/4cycle/fh721d_specs.html, 1 page, Feb. 2, 2005.

Kawasaki, Four-Cycle Engines, Kawasaki FH601D, website, http://www.kawpowr.com/4cycle/fh601d_specs.html, 1 page, Feb. 2, 2005.

Kawasaki, Four-Cycle Engines, Kawasaki FH601V, website, http://www.kawpowr.com/4cycle/fh601v_specs.html, 1 page, Feb. 2, 2005.

Kawasaki, Four-Cycle Engines, Kawasaki FH500V, website, http://www.kawpowr.com/4cycle/fh500v_specs.html, 1 page, Feb. 2, 2005.

Kawasaki, Four-Cycle Engines, Kawasaki FC150V, website, http://www.kawpowr.com/4cycle/fc150v_specs.html, 1 page, Feb. 2, 2005.

Kawasaki, Four-Cycle Engines, Kawasaki FH721V, website, http://www.kawpowr.com/4cycle/fh721v_specs.html, 1 page, Feb. 2, 2005.

(Continued)

Primary Examiner—Marcus A. Jackson

Assistant Examiner—Maurice Stevens

(74) *Attorney, Agent, or Firm*—Michael Best & Friedrich, LLP

(57) **CLAIM**

The ornamental design for an engine cover, as shown and described.

DESCRIPTION

FIG. 1 is a perspective view of an engine cover according to one embodiment of the invention;

FIG. 2 is a top view of the engine cover of FIG. 1;

FIG. 3 is a front view of the engine cover of FIG. 1;

FIG. 4 is a rear view of the engine cover of FIG. 1;

FIG. 5 is a left side view of the engine cover of FIG. 1; and,

FIG. 6 is a right side view of the engine cover of FIG. 1.

The broken line showing of the environment is for illustrative purposes only and forms no part of the claimed design. The bottom view of the engine cover forms no part of the claimed design.

1 Claim, 6 Drawing Sheets-

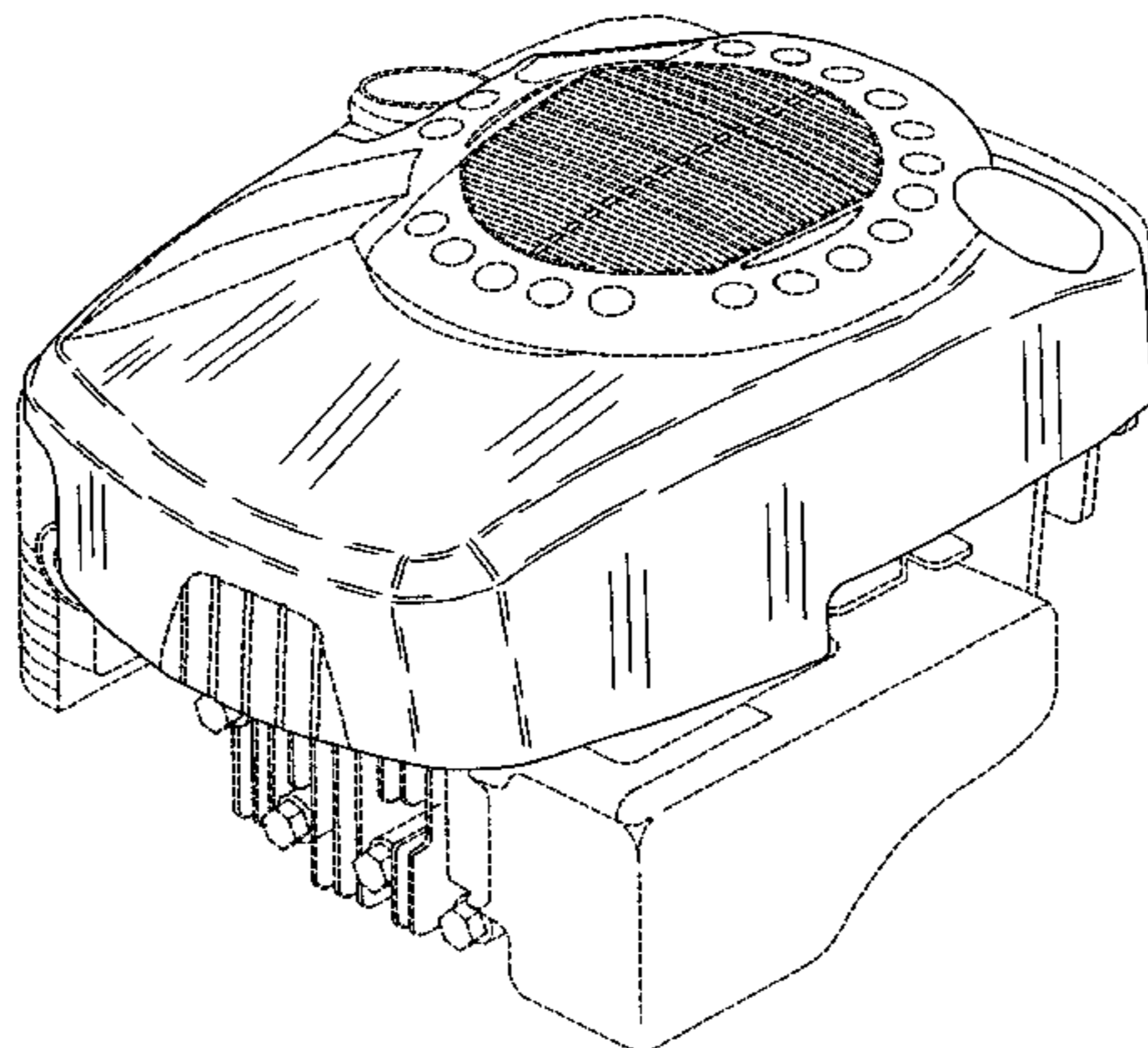

U.S. PATENT DOCUMENTS

5,197,426	A	3/1993	Frangesch et al.	
5,199,389	A	4/1993	Wold et al.	
5,251,428	A	10/1993	Gay	
D352,043	S	11/1994	Davies, III	
D361,771	S	8/1995	Ledingham	
D379,995	S	* 6/1997	Gilmore	D15/1
D396,045	S	7/1998	Neeley	
D396,478	S	* 7/1998	Hubbach	D15/5
D471,207	S	* 3/2003	Kern et al.	D15/5
D479,244	S	* 9/2003	Kern et al.	D15/5
D490,818	S	* 6/2004	Hieke	D15/5

OTHER PUBLICATIONS

Tecumseh Power Company; Walk-Behind Engines & Transmissions Horsepower Range: 3.5-7.0, website <http://www.tecumsehpower.com/Products/WalkBehind/index.php>, 1 page, Feb. 2, 2005.

Kohler Co. Engine Division; Kohler Engines Born to Run Owner's Manual, Command 11-16 HP Vertical Crankshaft; Cover Sheet, Revised Sep. 1999, Kohler Co. Engine Division, Kohler, Wisconsin, USA.

Kohler Co. Engine Division; Kohler Engines Born to Run Owner's Manual, Command 18-26 HP Horizontal Crankshaft; Cover Sheet, Revised May 1999, Kohler Co. Engine Division, Kohler, Wisconsin, USA.

Kohler Co. Engine Division; Kohler Engines Born to Run Owner's Manual, Command 11-15 HP Horizontal Crankshaft; Cover Sheet, Revised Apr. 1999, Kohler Co. Engine Division, Kohler, Wisconsin, USA.

Kohler Co. Engine Division; Kohler Engines Born to Run Owner's Manual, Magnum 8,12,16 HP Horizontal Crankshaft; Cover Sheet; Revised Dec. 2001, Kohler Co. Engine Division, Kohler, Wisconsin, USA.

Kohler Co. Engine Division; Kohler Engines Service Manual, Courage Series SV470-600 Vertical Crankshaft; website http://www.kohlerengines.com/onlinecatalog/detail.jsp?prod_num=Hydro+13, Cover Sheet, Feb. 2, 2005, Kohler Co. Engine Division, Kohler, Wisconsin, USA.

Kohler Co. Engine Division; Kohler Engines Kohler Triad OHC; website http://www.kohlerengines.com/onlinecatalog/enginefamily.jsp?engine_family_name=Triad+OHC, Cover Sheet Feb. 2, 2005, Kohler Co. Engine Division, Kohler, Wisconsin, USA.

Honda Engines, Honda GC Series Engines, brochure, 2003, 10 pages, American Honda Motor Co, Inc.

Briggs & Stratton Corporation; 04 Engine Guide; brochure; at least as early as Mar. 1, 2004; pp. 5-58 (excluding front & back covers); Wauwatosa, Wisconsin.

* cited by examiner

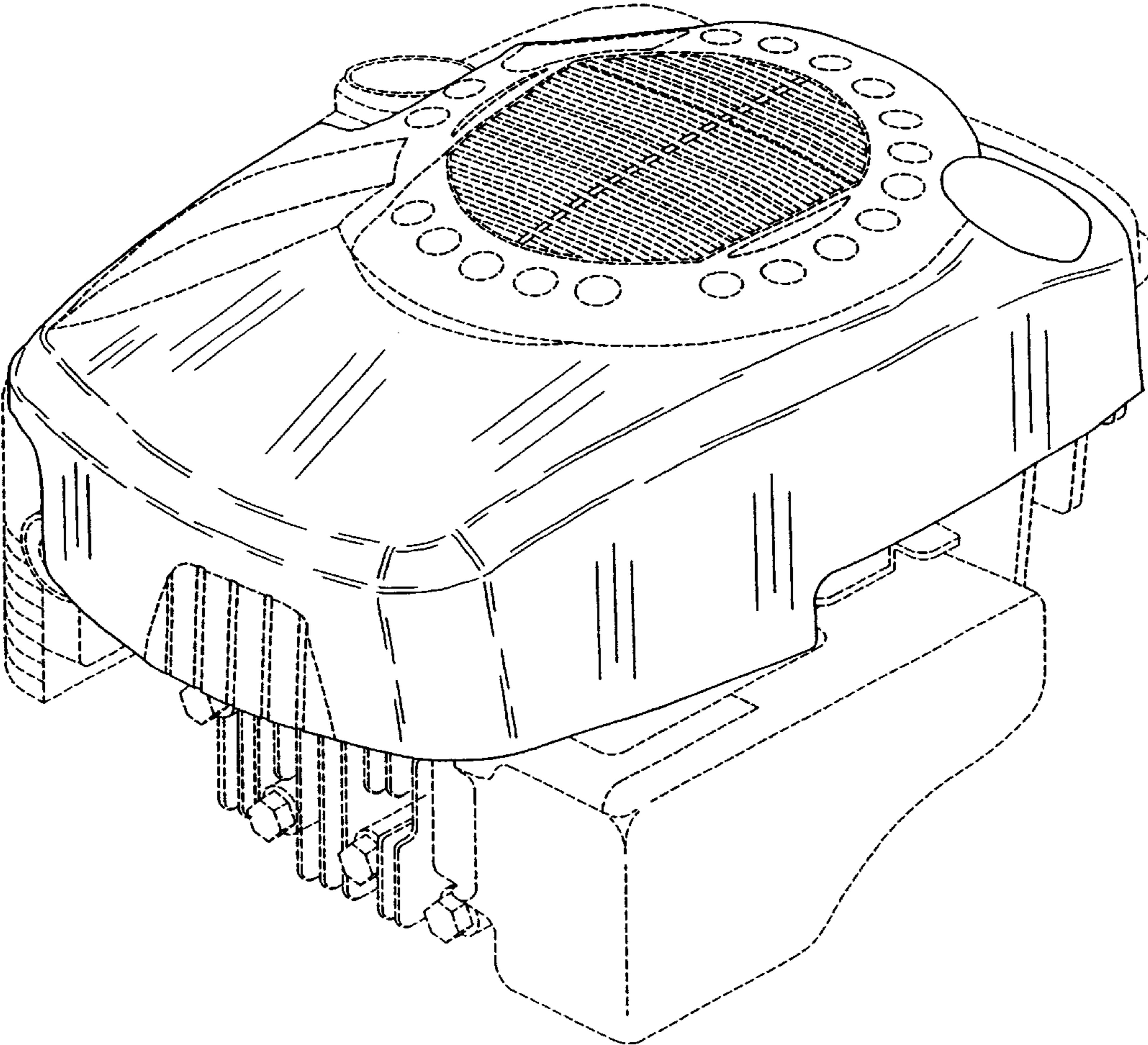

FIG. 1

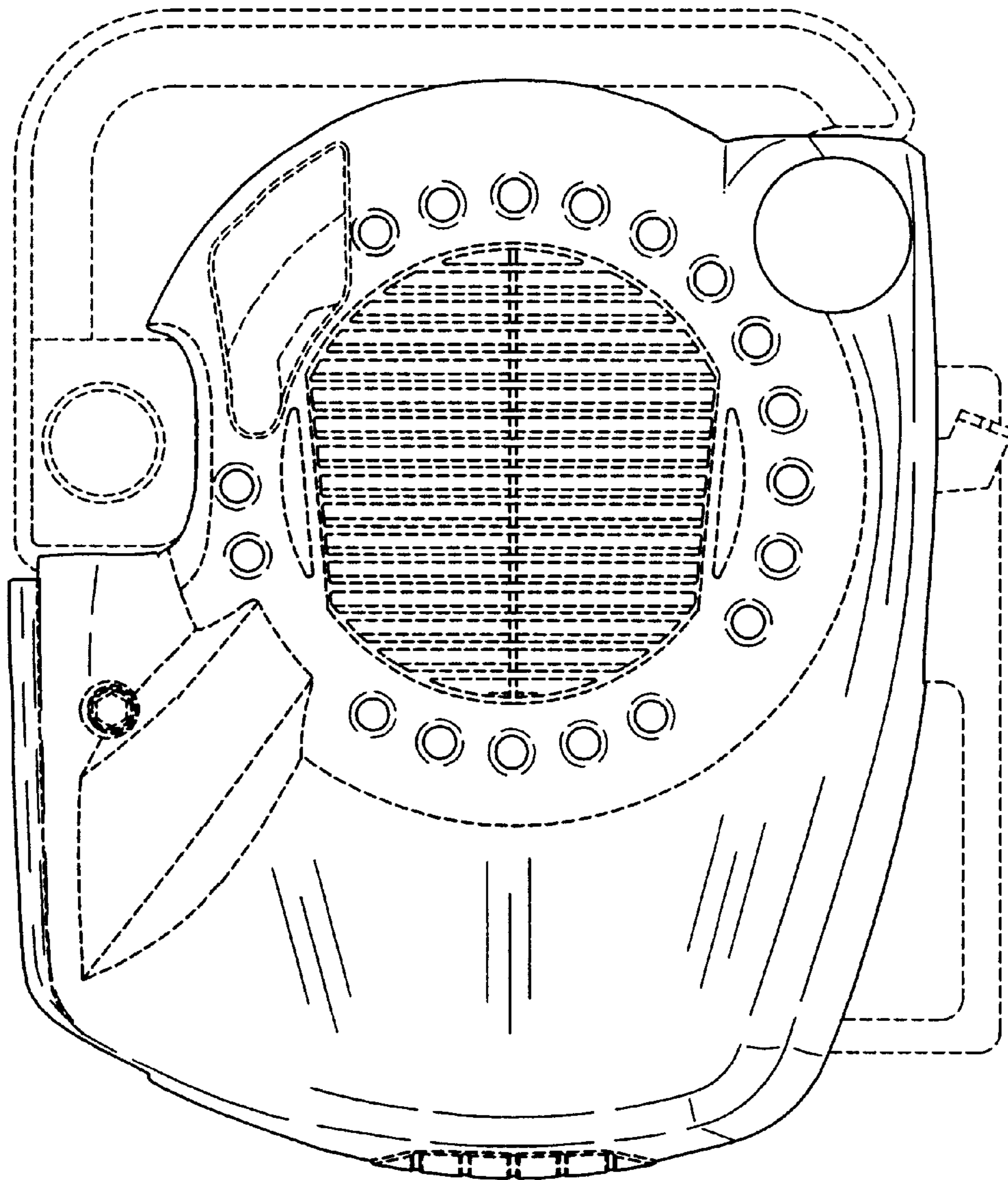

FIG. 2

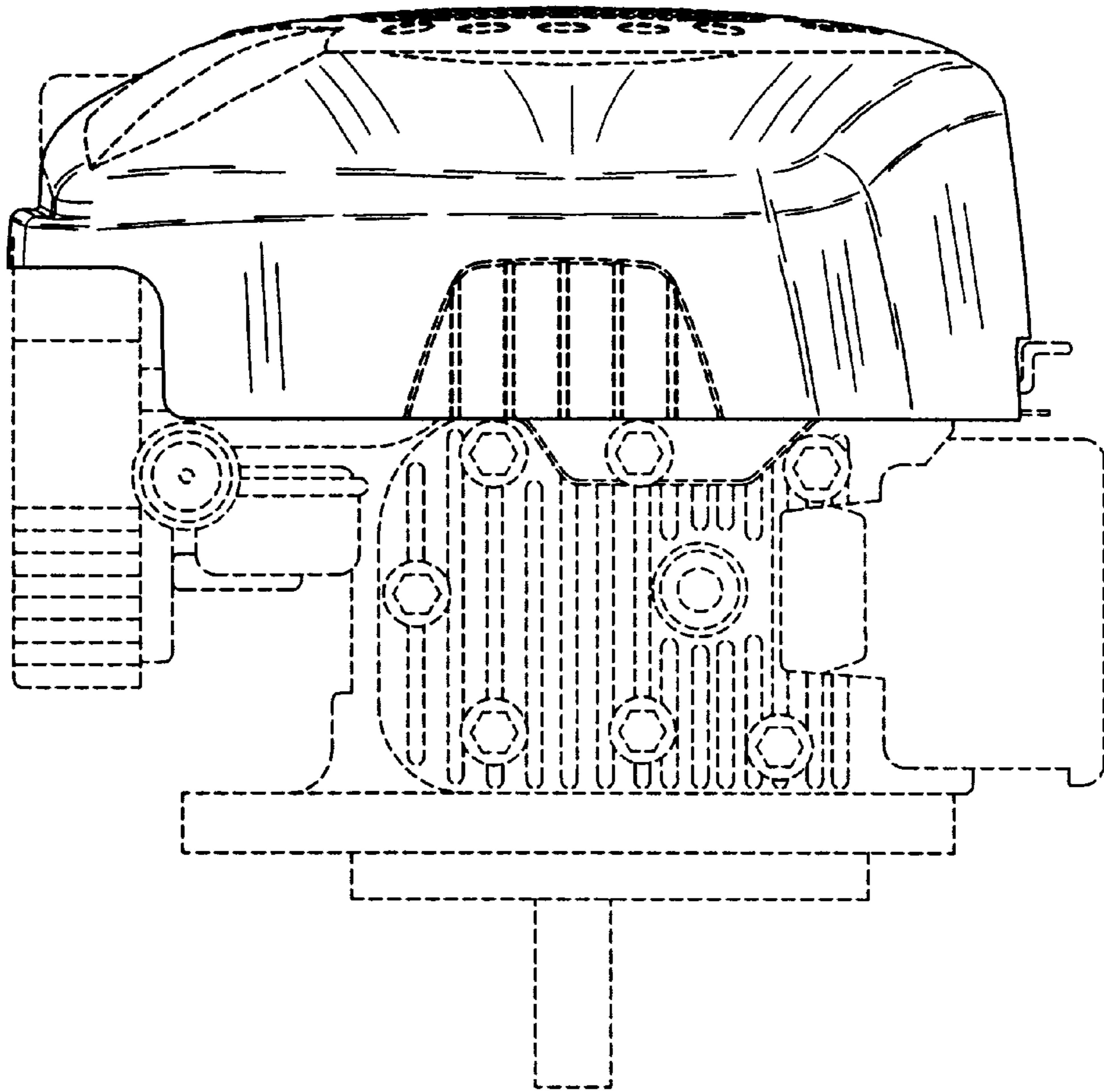

FIG. 3

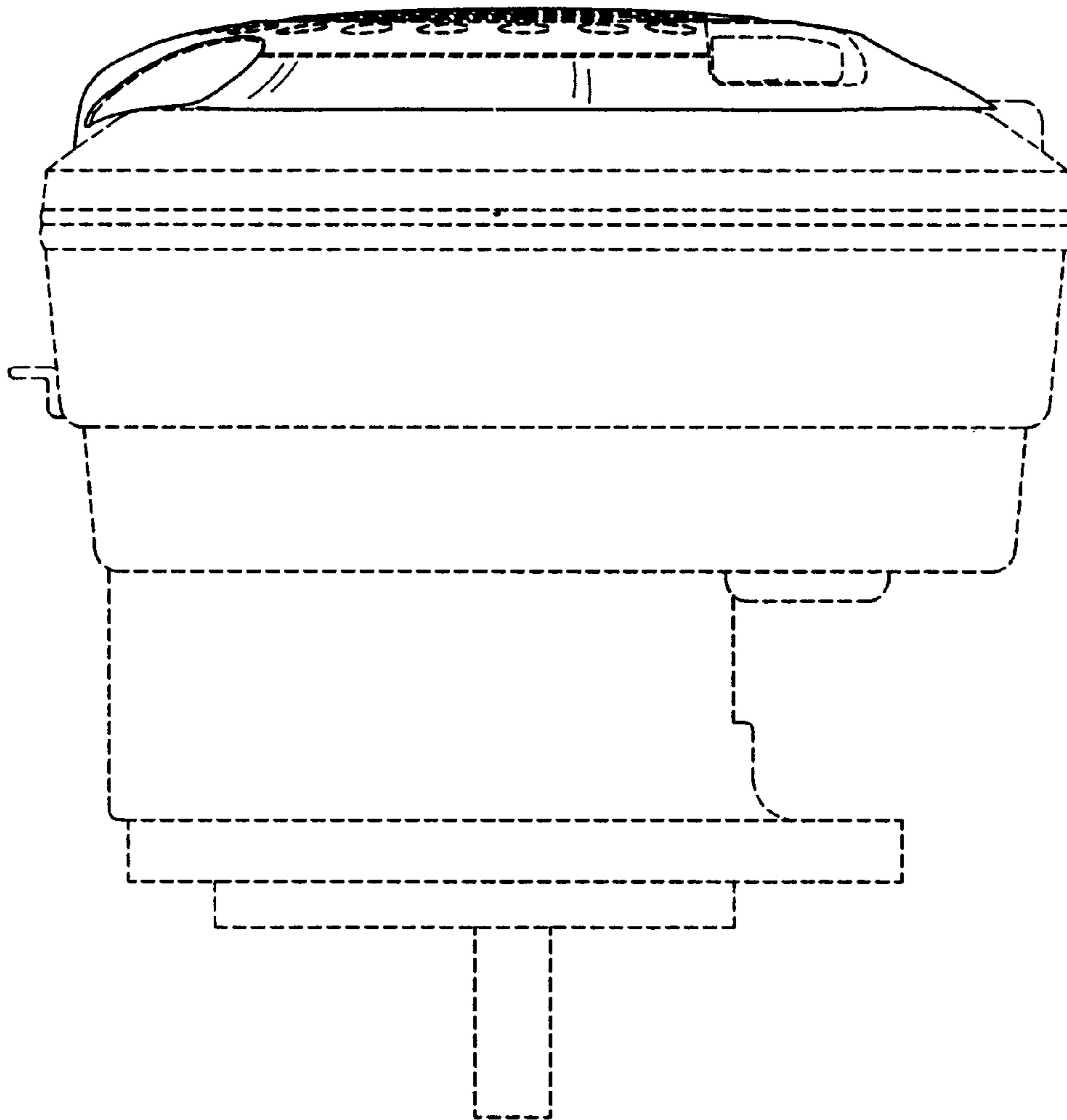

FIG. 4

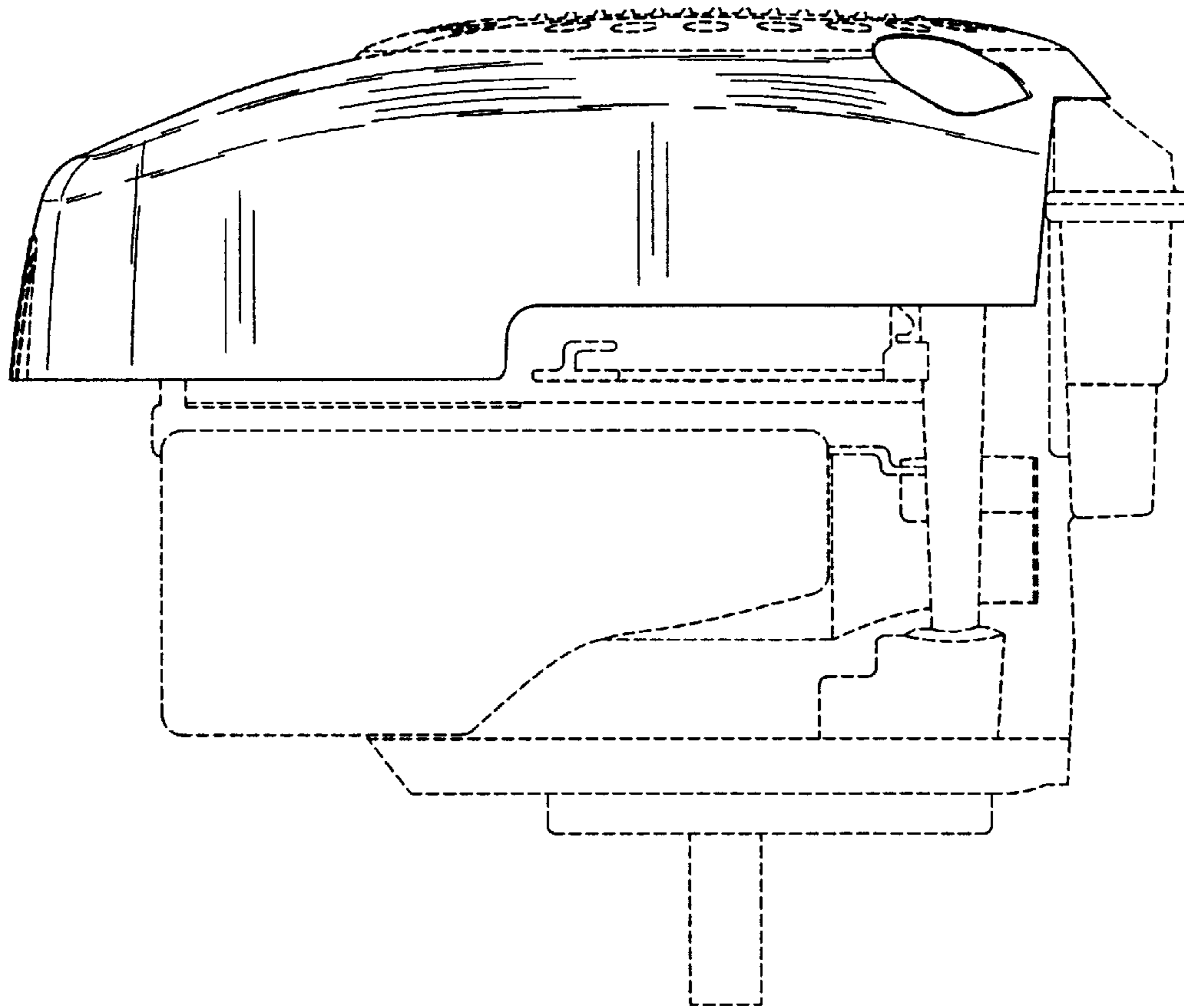

FIG. 5

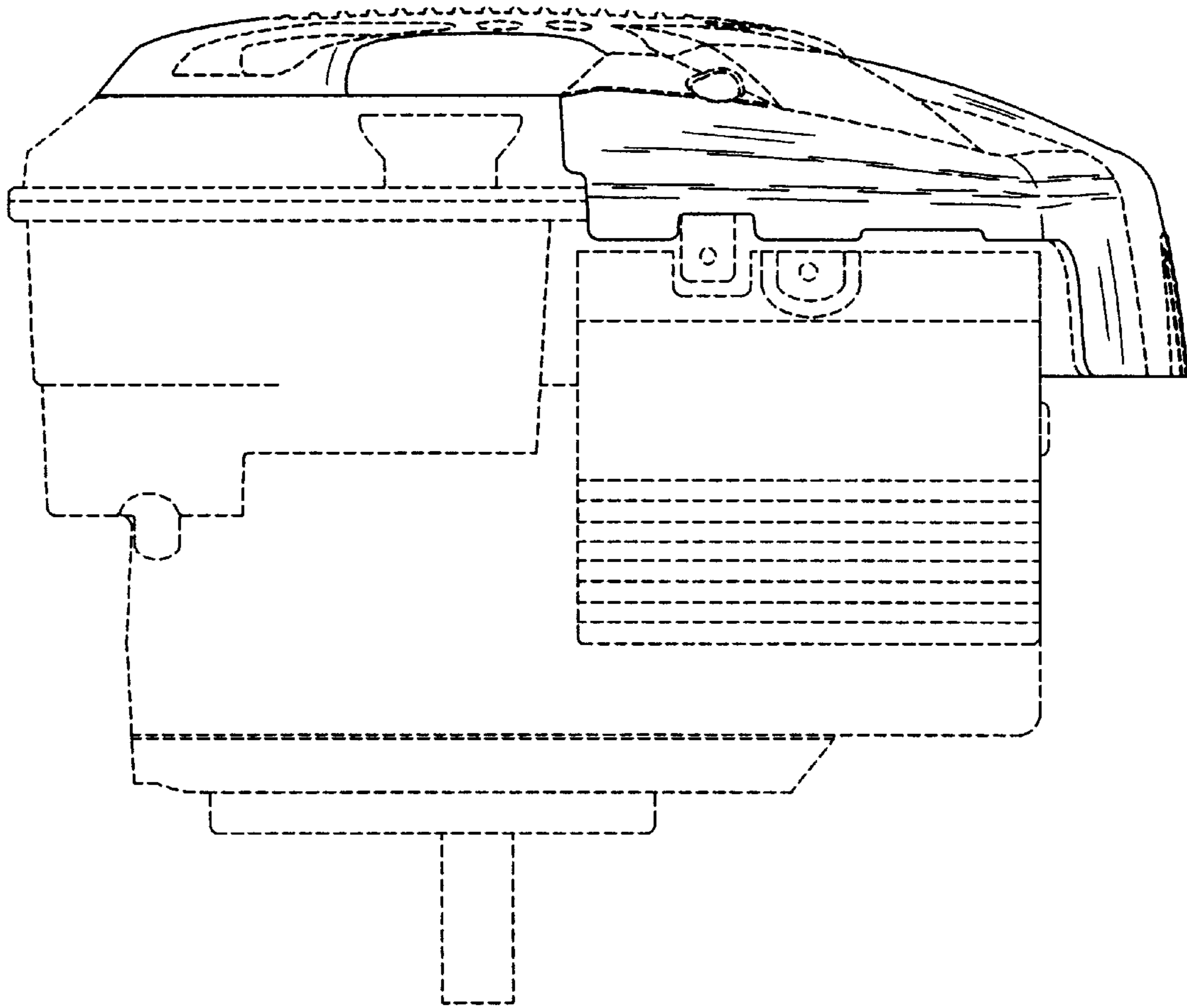

FIG. 6