



US00D525938S

(12) **United States Design Patent**
Seil et al.

(10) **Patent No.:** **US D525,938 S**

(45) **Date of Patent:** **** Aug. 1, 2006**

(54) **CIGARETTE LIGHTER ADAPTER HOUSING**

(75) Inventors: **Oliver Duncan Seil**, Pasadena, CA
(US); **Barry Sween**, Santa Monica, CA
(US); **David Kleeman**, Marina Del Ray,
CA (US)

(73) Assignee: **Balkin Corporation**, Compton, CA
(US)

(**) Term: **14 Years**

(21) Appl. No.: **29/238,238**

(22) Filed: **Sep. 12, 2005**

(51) **LOC (8) Cl.** **13-03**

(52) **U.S. Cl.** **D13/144**

(58) **Field of Classification Search** D13/107,
D13/110, 144, 184; D14/155, 240; 320/110-112,
320/114; 363/146; 439/300, 620, 638, 668,
439/669, 675, 825

See application file for complete search history.

(56) **References Cited**

U.S. PATENT DOCUMENTS

D315,543 S	*	3/1991	Soren et al.	D13/144
D403,663 S	*	1/1999	Jones et al.	D13/144
D406,261 S	*	3/1999	Kettula et al.	D13/144
D409,568 S	*	5/1999	Lindahl	D13/144
5,964,623 A	*	10/1999	Maher et al.	439/668
D436,080 S	*	1/2001	Hussaini et al.	D13/144

D442,543 S	*	5/2001	Krumenacker et al.	D13/107
D455,712 S	*	4/2002	Hsiao	D13/108
D469,400 S	*	1/2003	Shor et al.	D13/107
D489,326 S	*	5/2004	Nazar	D13/110
D490,058 S	*	5/2004	Mkhitarian	D13/144
D506,455 S	*	6/2005	Bey et al.	D14/155
D507,527 S	*	7/2005	Huang	D13/110

* cited by examiner

Primary Examiner—Alan P. Douglas

Assistant Examiner—Rosemary K. Tarcza

(74) *Attorney, Agent, or Firm*—Bryan Cave LLP

(57) **CLAIM**

We claim the ornamental design for a cigarette lighter adapter housing, as shown and described.

DESCRIPTION

FIG. 1 is a front elevational view of the cigarette lighter adapter housing;

FIG. 2 is a rear elevational view thereof;

FIG. 3 is a top view thereof;

FIG. 4 is a bottom view thereof;

FIG. 5 is a left side elevational view thereof, the right side elevational view being a mirror image of the left side elevational view;

FIG. 6 is a front, left, bottom perspective view thereof; and,

FIG. 7 is a rear, right, bottom perspective view thereof.

The broken lines in the drawings are for illustrative purposes only and form no part of the claimed design.

1 Claim, 2 Drawing Sheets

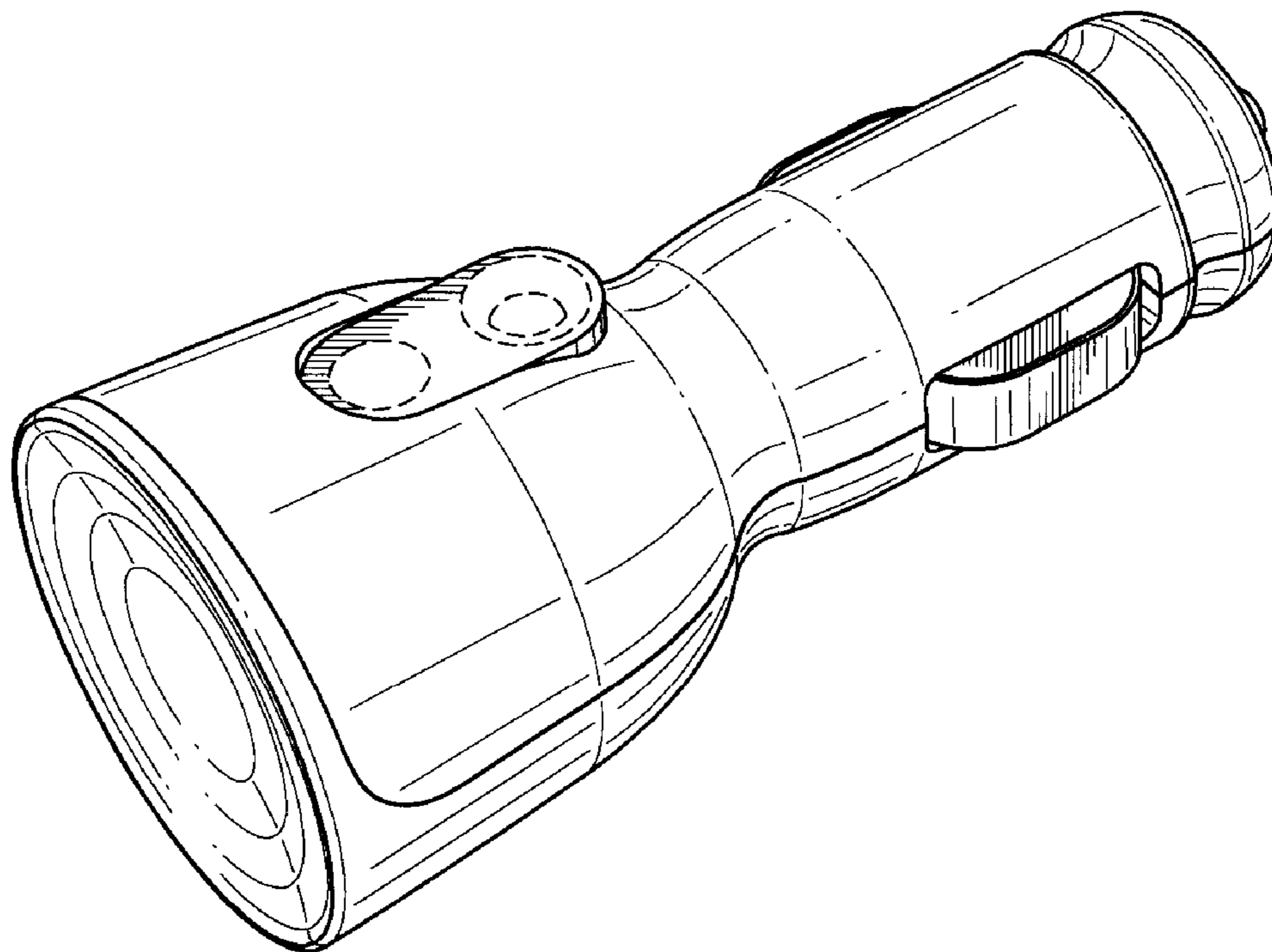

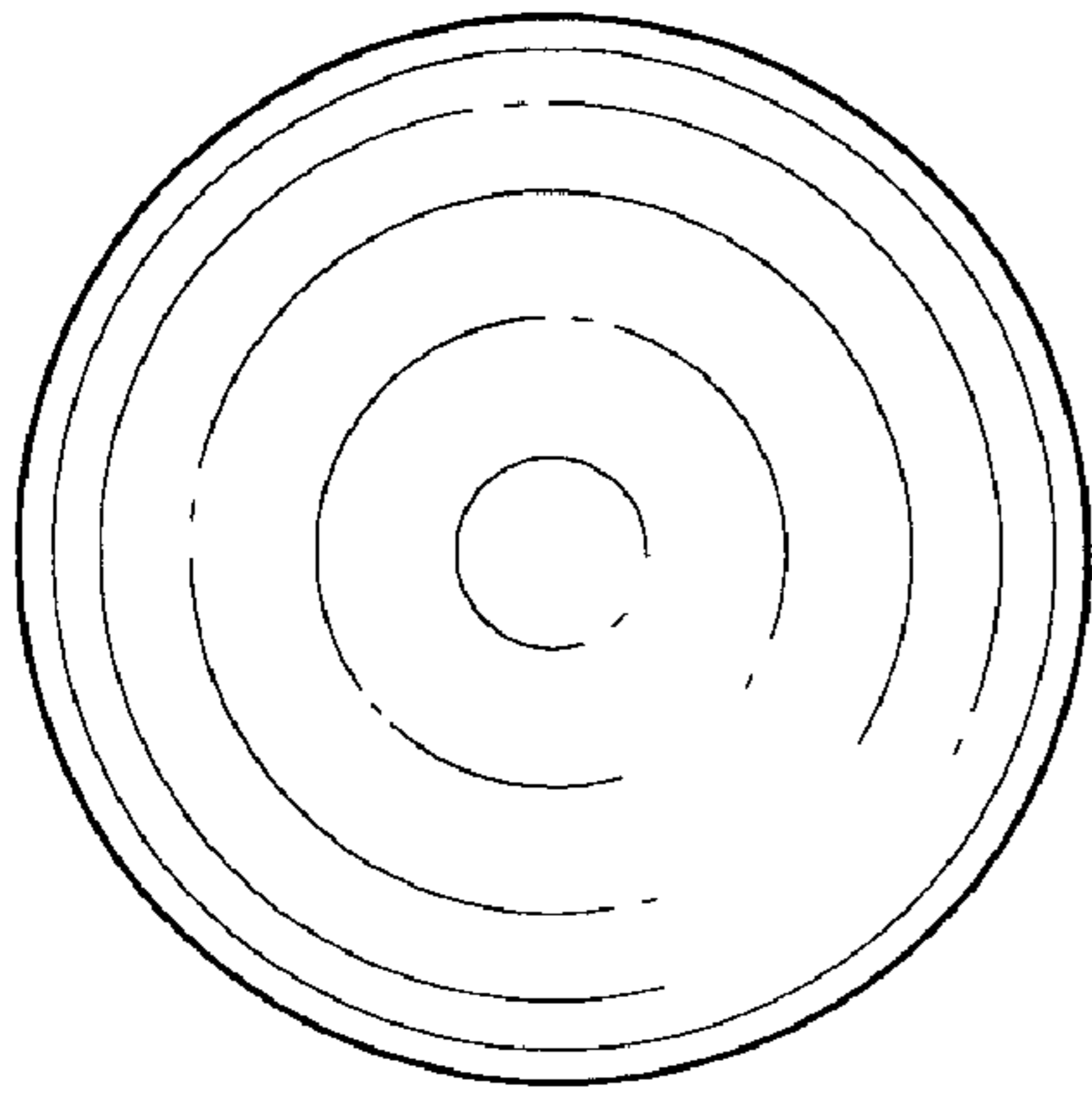

FIG. 1

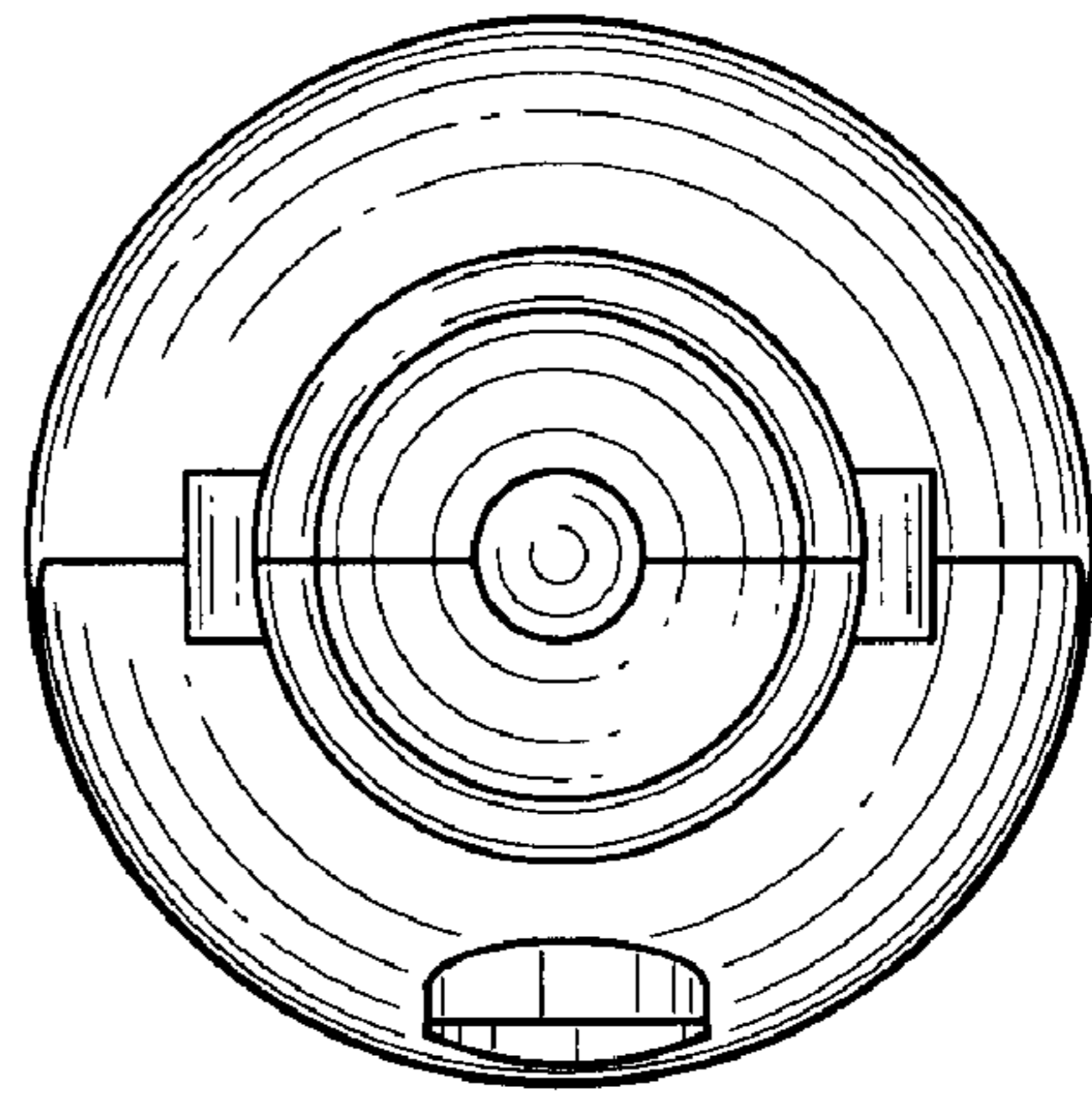

FIG. 2

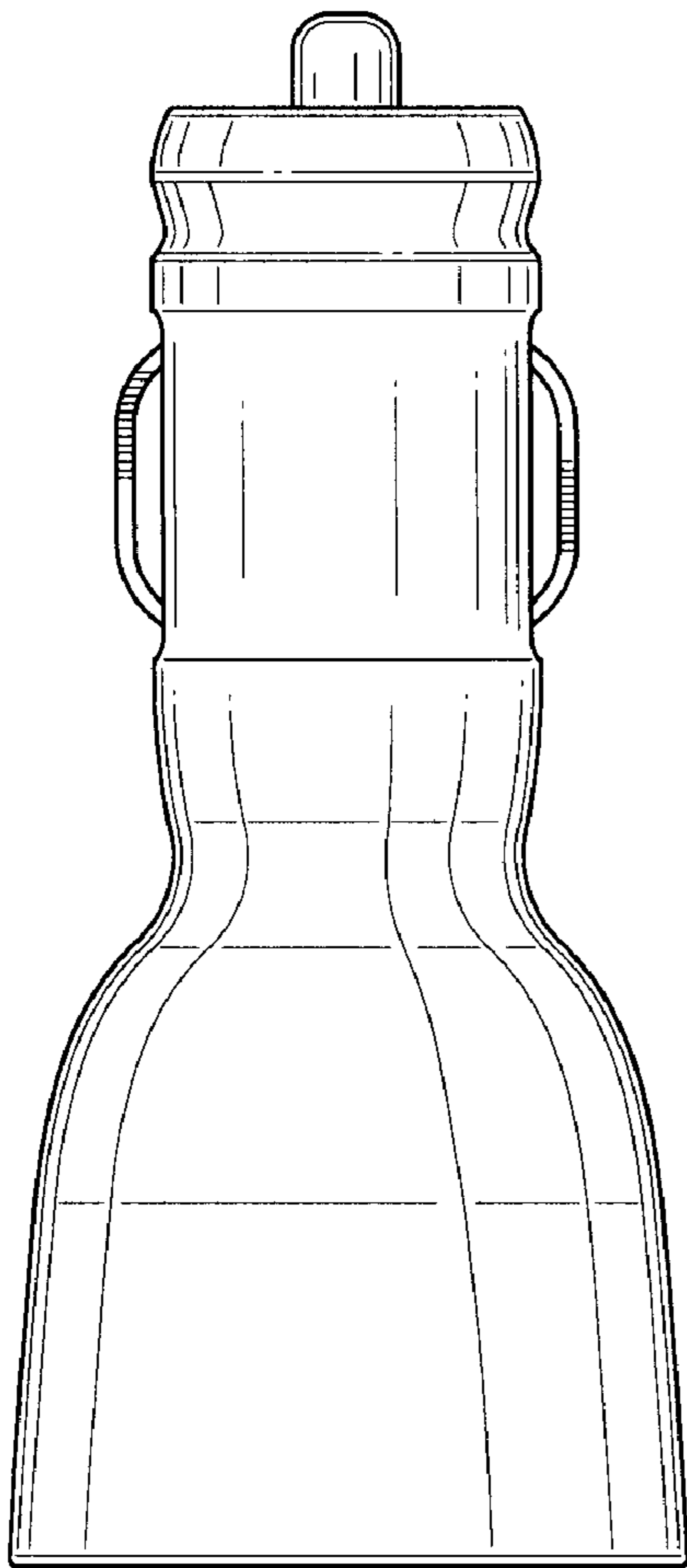

FIG. 3

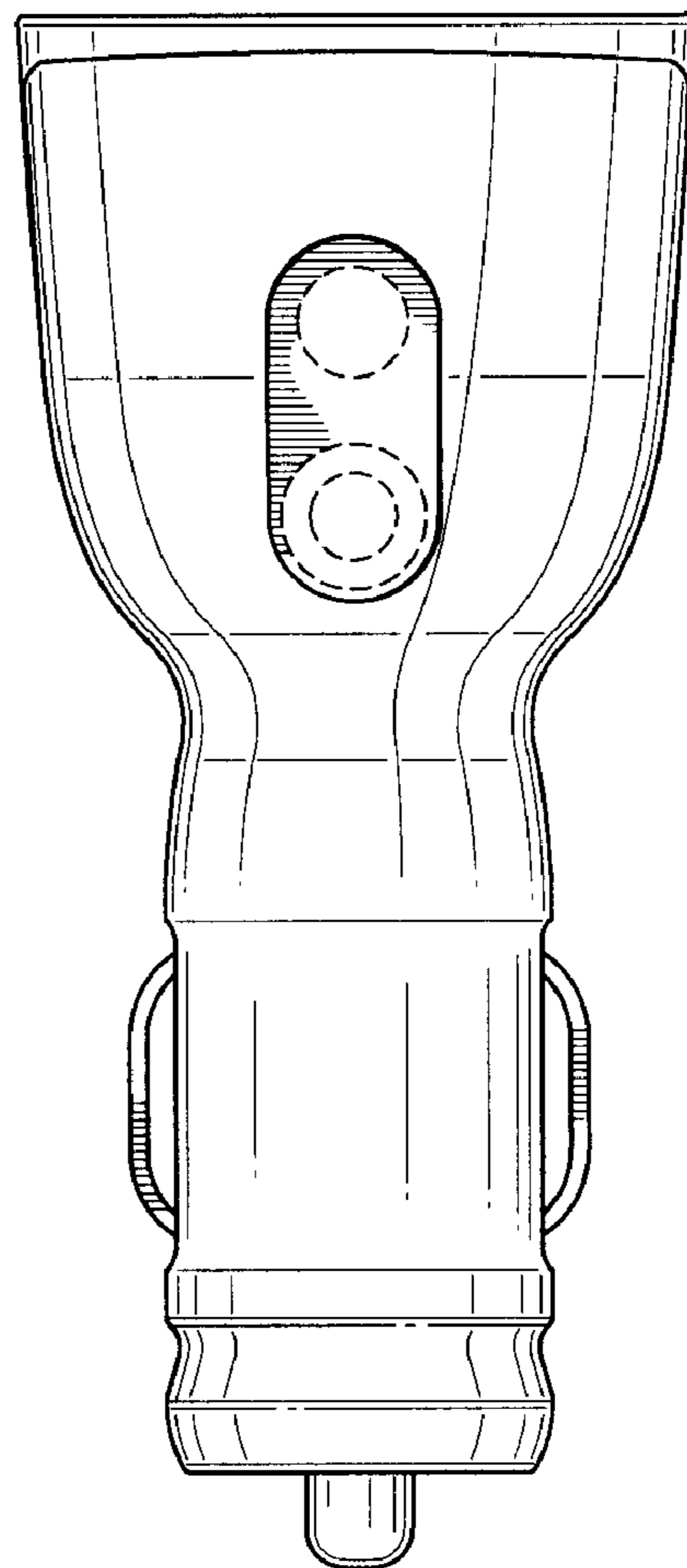

FIG. 4

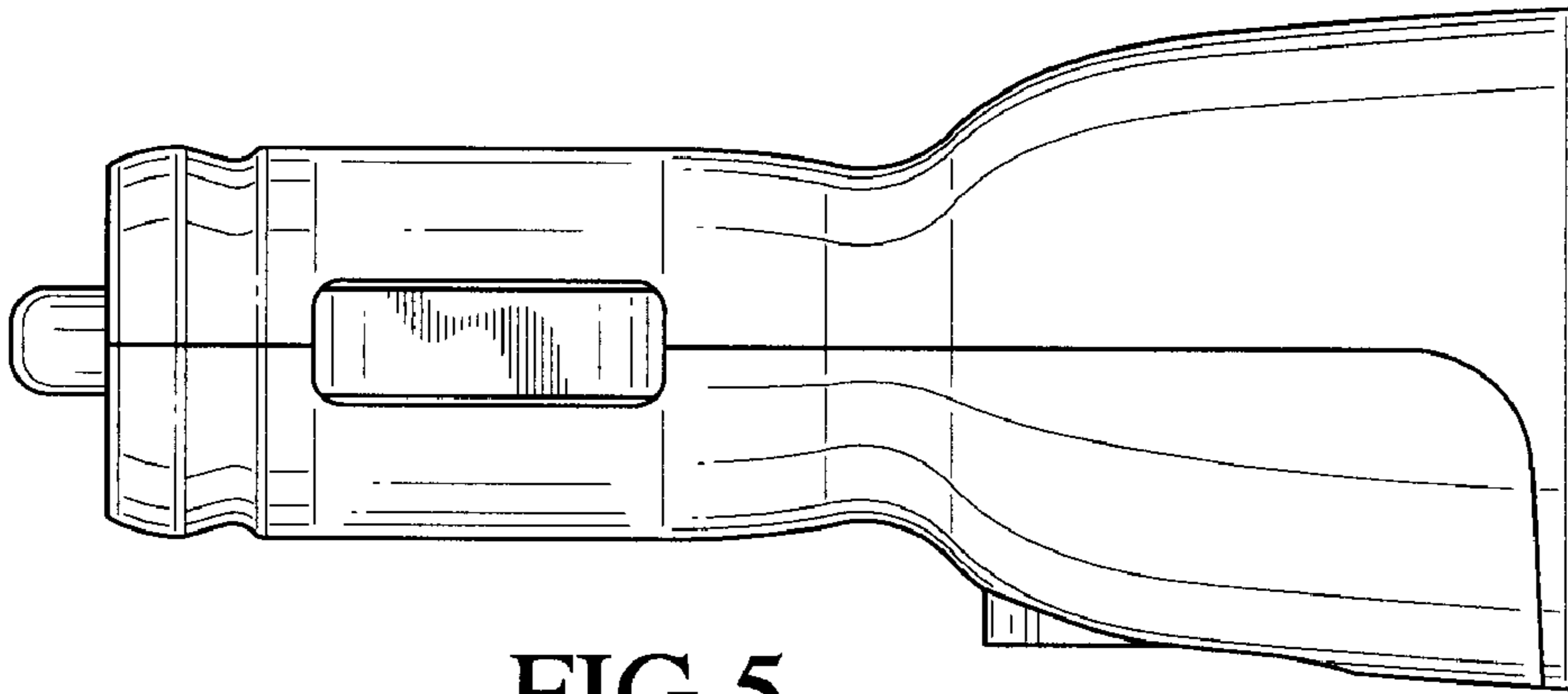

FIG. 5

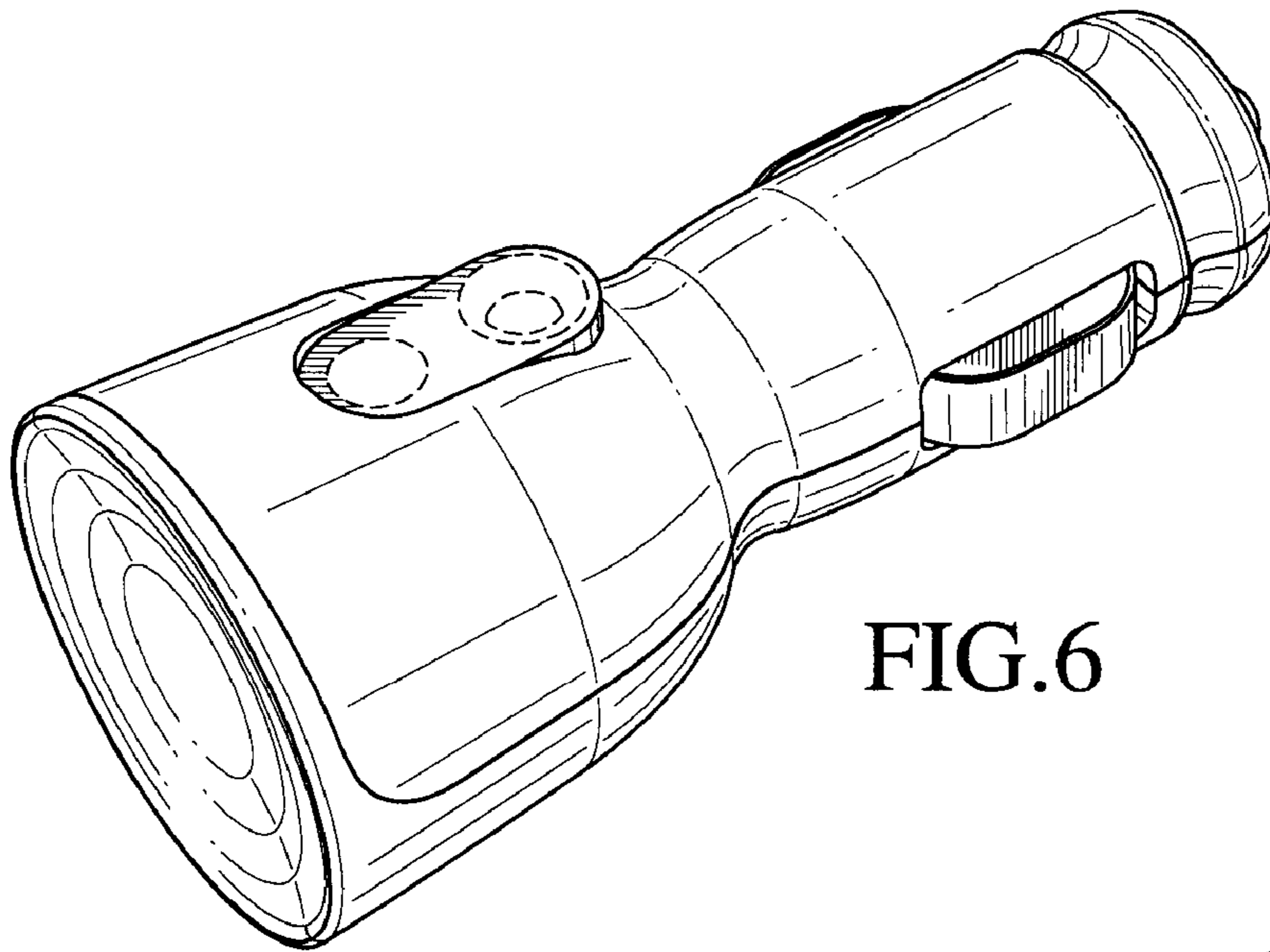

FIG. 6

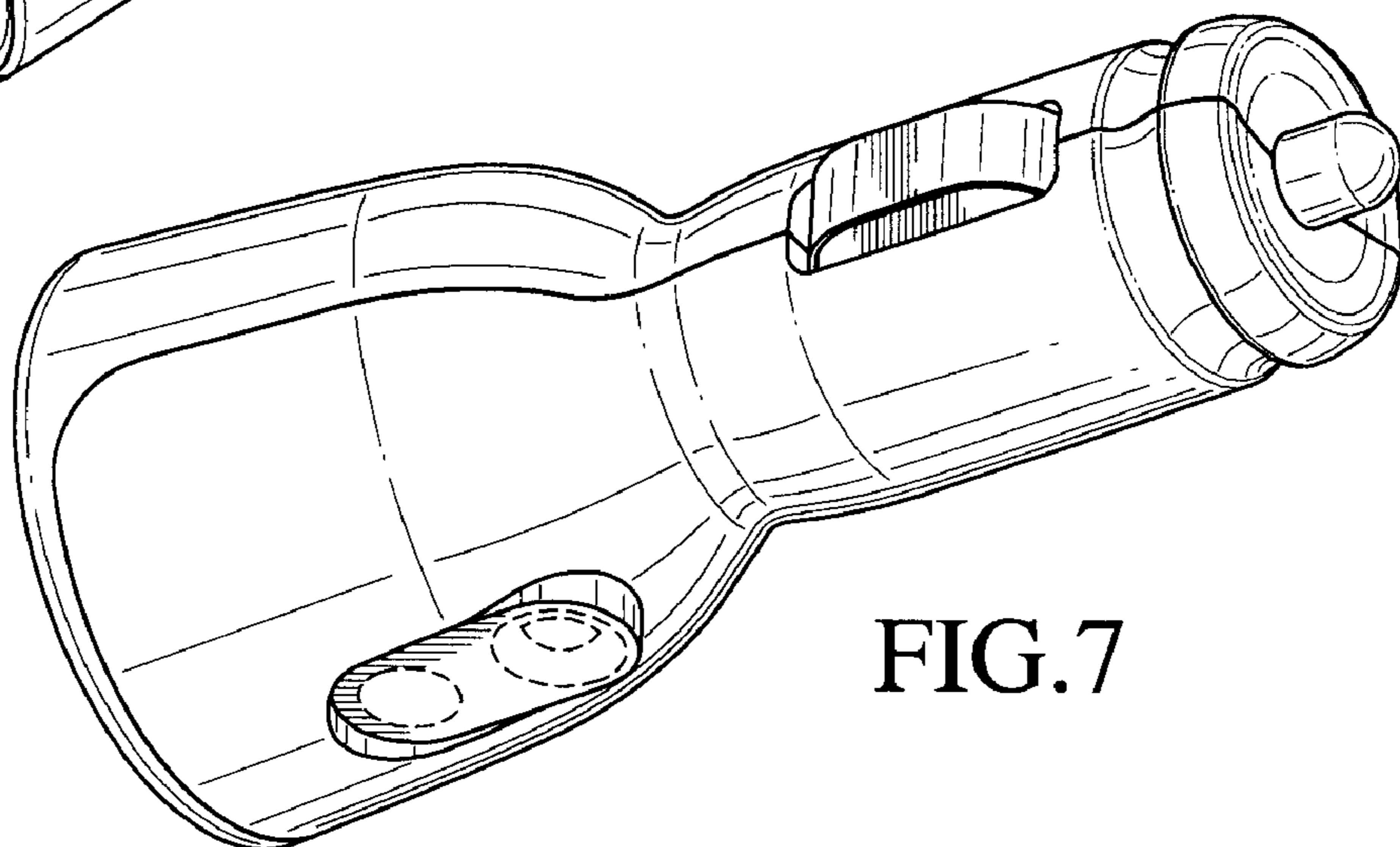

FIG. 7