

US00D525731S

(12) **United States Design Patent**  
**Hovind et al.**

(10) **Patent No.:** **US D525,731 S**  
(45) **Date of Patent:** **\*\* Jul. 25, 2006**

(54) **TRUCK HEADLAMP**

(75) Inventors: **Steven H Hovind**, Bellevue, WA (US);  
**Gerald Jay Angelo**, Bellevue, WA  
(US); **Daniel R Kieffer**, Kirkland, WA  
(US); **Wayne K Simons**, Kent, WA  
(US); **Daniel Farmer**, Coupeville, WA  
(US); **Richard D Wailes, Jr.**,  
Woodinville, WA (US); **Erik David  
Hjorten**, Everett, WA (US)

(73) Assignee: **PACCAR Inc**, Bellevue, WA (US)

(\*\*) Term: **14 Years**

(21) Appl. No.: **29/238,135**

(22) Filed: **Sep. 12, 2005**

(51) **LOC (8) Cl.** ..... **26-06**

(52) **U.S. Cl.** ..... **D26/28**

(58) **Field of Classification Search** ..... D26/28-36;  
362/459-468, 475-478, 485-487

See application file for complete search history.

(56) **References Cited**

**U.S. PATENT DOCUMENTS**

D291,872 S 9/1987 Simons et al.  
D291,982 S 9/1987 Simons et al.

(Continued)

**OTHER PUBLICATIONS**

Kenworth Truck Company W900 brochure, Kirkland, Wash,  
2005.

Kenworth Truck Company W900 brochure, Kirkland, Wash,  
2002.

Kenworth Truck Company W900 brochure, Kirkland, Wash,  
1996.

Kenworth Truck Company T2000 brochure, Kirkland,  
Wash, 2005.

Kenworth Truck Company T2000 brochure, Kirkland,  
Wash, 2002.

Kenworth Truck Company T800 brochure, Kirkland, Wash,  
2005.

(Continued)

*Primary Examiner*—Marcus A. Jackson  
(74) *Attorney, Agent, or Firm*—Christensen O'Connor  
Johnson Kindness PLLC

(57) **CLAIM**

The ornamental design for a truck headlamp, as shown and  
described.

**DESCRIPTION**

FIG. 1 is a front perspective view of a truck headlamp  
showing a first embodiment of our new design;

FIG. 2 is a front elevational view of the truck headlamp of  
FIG. 1;

FIG. 3 is a rear elevational view of the truck headlamp of  
FIG. 1;

FIG. 4 is a top plan view of the truck headlamp of FIG. 1;  
FIG. 5 is a bottom plan view of the truck headlamp of FIG.

1;

FIG. 6 is a left side elevational view of the truck headlamp  
of FIG. 1;

FIG. 7 is a right side elevational view of the truck headlamp  
of FIG. 1;

FIG. 8 is a front perspective view of a truck headlamp  
showing a second embodiment of our new design;

FIG. 9 is a front elevational view of the truck headlamp of  
FIG. 8;

FIG. 10 is a rear elevational view of the truck headlamp of  
FIG. 8;

FIG. 11 is a top plan view of the truck headlamp of FIG. 8;  
FIG. 12 is a bottom plan view of the truck headlamp of FIG.

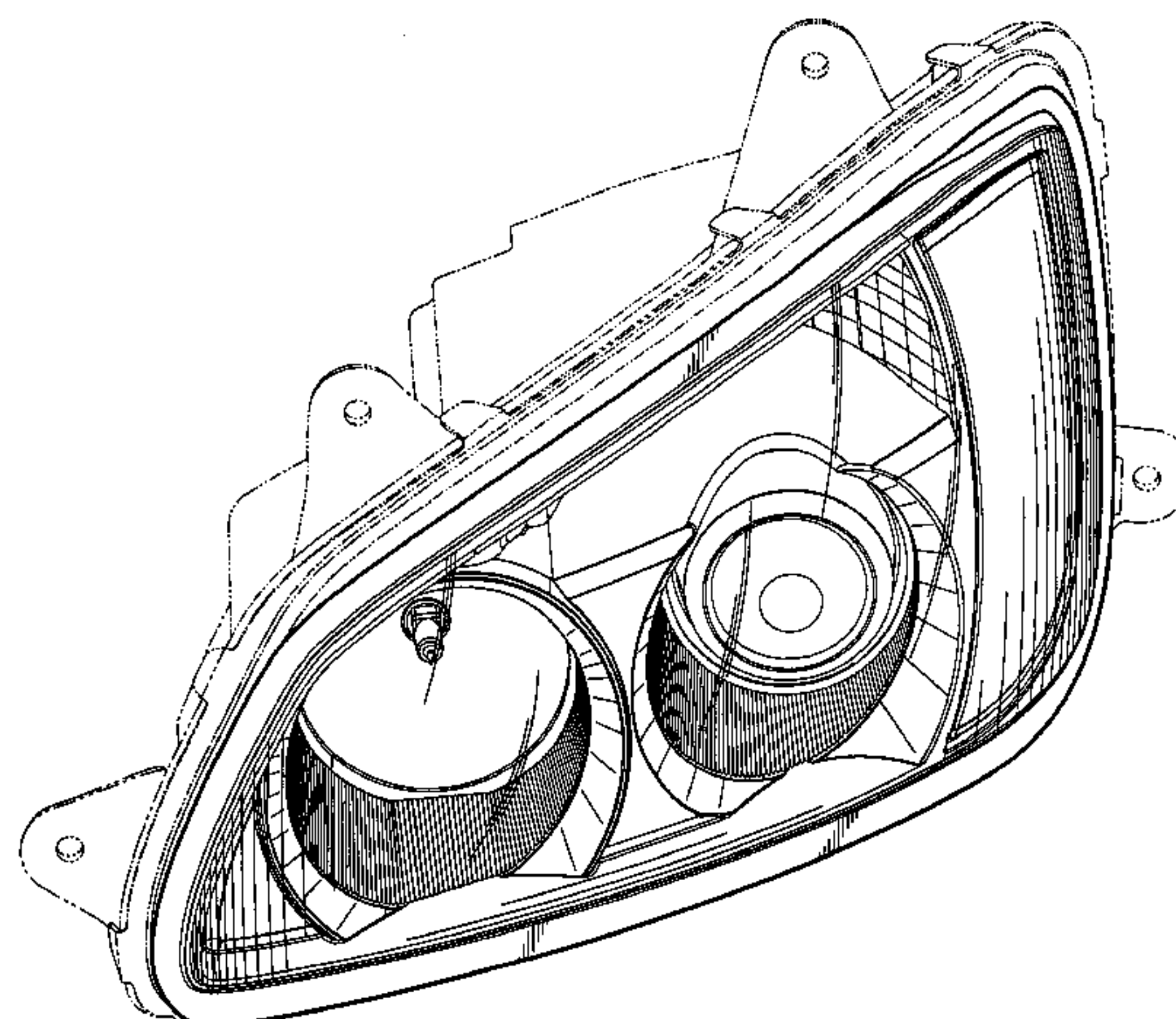
8;

FIG. 13 is a left side elevational view of the truck headlamp  
of FIG. 8; and,

FIG. 14 is a right side elevational view of the truck headlamp  
of FIG. 8.

The broken lines in the drawings form no part of the claimed  
design.

**1 Claim, 10 Drawing Sheets**



U.S. PATENT DOCUMENTS

D307,731 S 5/1990 Kerney et al.  
 D308,032 S 5/1990 Kerney et al.  
 D312,805 S 12/1990 Marlowe et al.  
 D313,966 S 1/1991 Marlowe et al.  
 D320,583 S 10/1991 Simons et al.  
 D329,214 S 9/1992 Marlowe et al.  
 D343,605 S 1/1994 Meryman  
 D343,916 S 2/1994 King et al.  
 D363,561 S 10/1995 Lagaay et al.  
 D366,638 S 1/1996 Tucker et al.  
 D382,841 S 8/1997 Norwood et al.  
 D384,019 S 9/1997 Meryman et al.  
 D395,860 S 7/1998 Meryman et al.  
 D403,636 S 1/1999 Meryman et al.  
 D411,140 S 6/1999 Meryman et al.  
 D411,494 S 6/1999 Meryman et al.  
 D414,571 S 9/1999 Schneider et al.  
 D421,817 S 3/2000 Tucker et al.  
 D422,251 S 4/2000 Bader et al.  
 D423,990 S 5/2000 Meryman et al.  
 D424,489 S 5/2000 Damon et al.  
 D425,450 S 5/2000 Barraclough et al.  
 D426,905 S 6/2000 Cook et al.  
 D431,806 S 10/2000 Damon et al.  
 D433,981 S 11/2000 Davis et al.  
 D434,347 S 11/2000 Damon et al.  
 D436,894 S 1/2001 Barraclough et al.  
 D437,258 S 2/2001 Meryman et al.  
 D437,570 S 2/2001 Meryman et al.  
 D458,397 S 6/2002 Horowitz  
 D470,956 S 2/2003 Horowitz  
 D475,657 S 6/2003 Wong et al.  
 D477,427 S 7/2003 Mazziotti

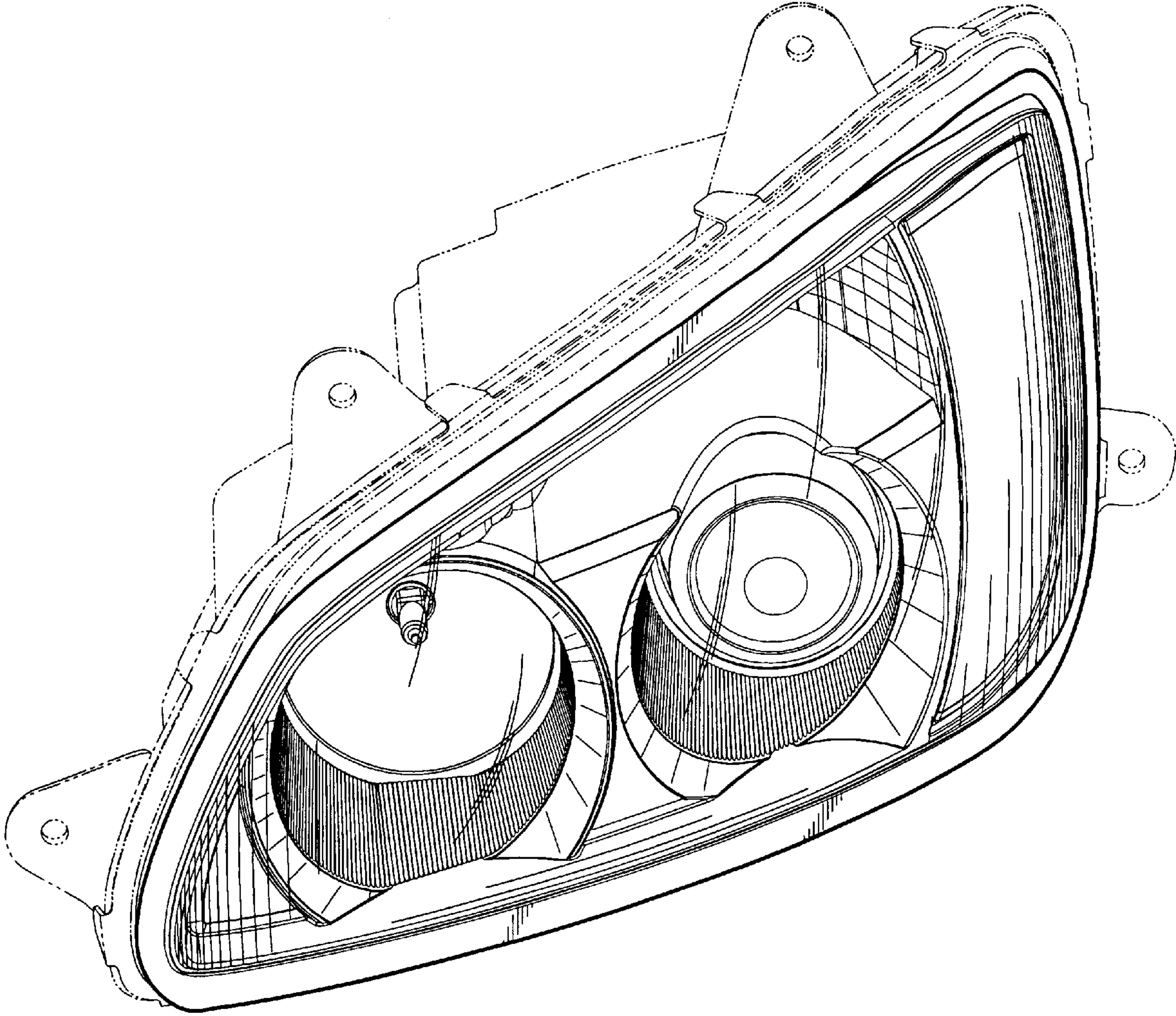
D484,261 S \* 12/2003 Liao ..... D26/28  
 D485,381 S \* 1/2004 Lung ..... D26/28  
 D490,560 S 5/2004 Zyskowski  
 D493,552 S 7/2004 Metros et al.  
 D493,902 S 8/2004 Hoelzel et al.  
 D494,293 S 8/2004 Pfeiffer  
 D495,071 S 8/2004 Pfeiffer  
 D498,010 S 11/2004 Pfeiffer et al.  
 D498,314 S 11/2004 Pfeiffer et al.  
 D499,496 S 12/2004 Papke et al.  
 D499,822 S 12/2004 Pfeiffer  
 D500,565 S 1/2005 Hoelzel et al.  
 D504,186 S 4/2005 Pfeiffer  
 D506,842 S \* 6/2005 Nagura et al. .... D26/28  
 D507,362 S \* 7/2005 Minami ..... D26/28

OTHER PUBLICATIONS

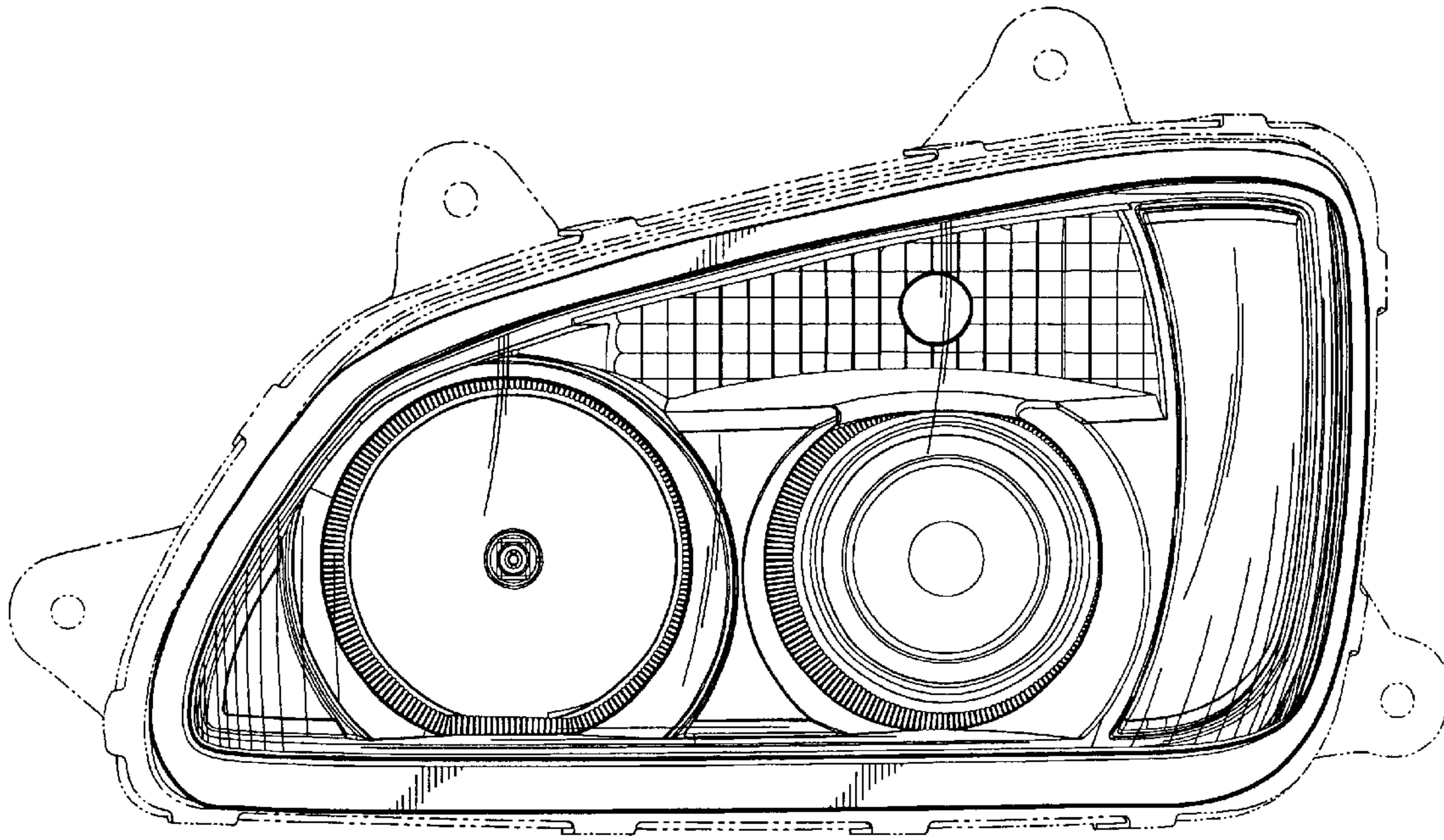
Kenworth Truck Company T800 brochure, Kirkland, Wash,  
 2003.  
 Kenworth Truck Company T800 brochure, Kirkland, Wash,  
 2002.  
 Kenworth Truck Company T600 brochure, Kirkland, Wash,  
 2005.  
 Kenworth Truck Company T600 brochure, Kirkland, Wash,  
 2002.  
 Kenworth Truck Company T600 brochure, Kirkland, Wash,  
 1996.  
 Kenworth Truck Company T300 brochure, Kirkland, Wash,  
 2005.  
 Kenworth Truck Company T300 brochure, Kirkland, Wash,  
 2001.

\* cited by examiner

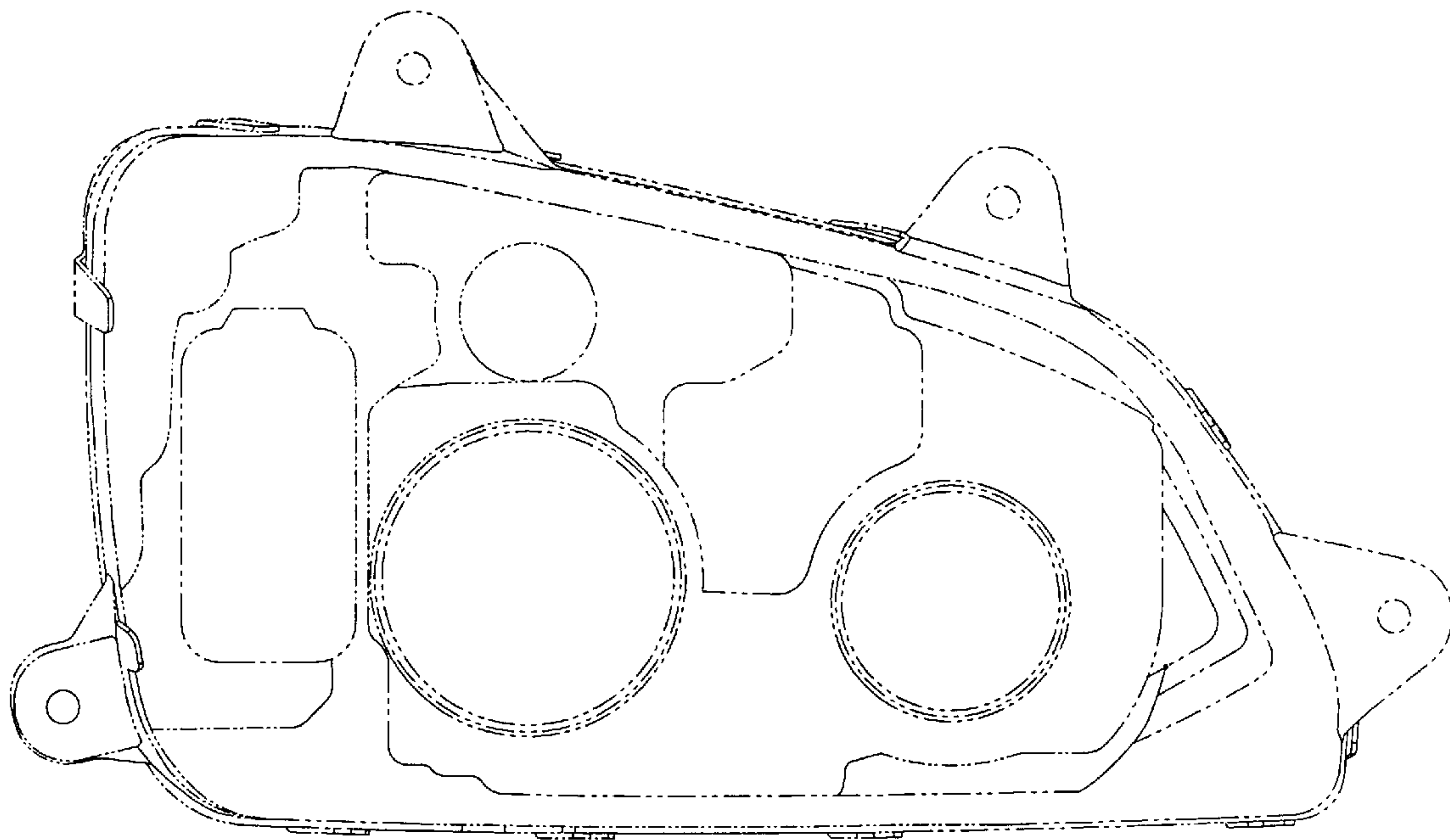




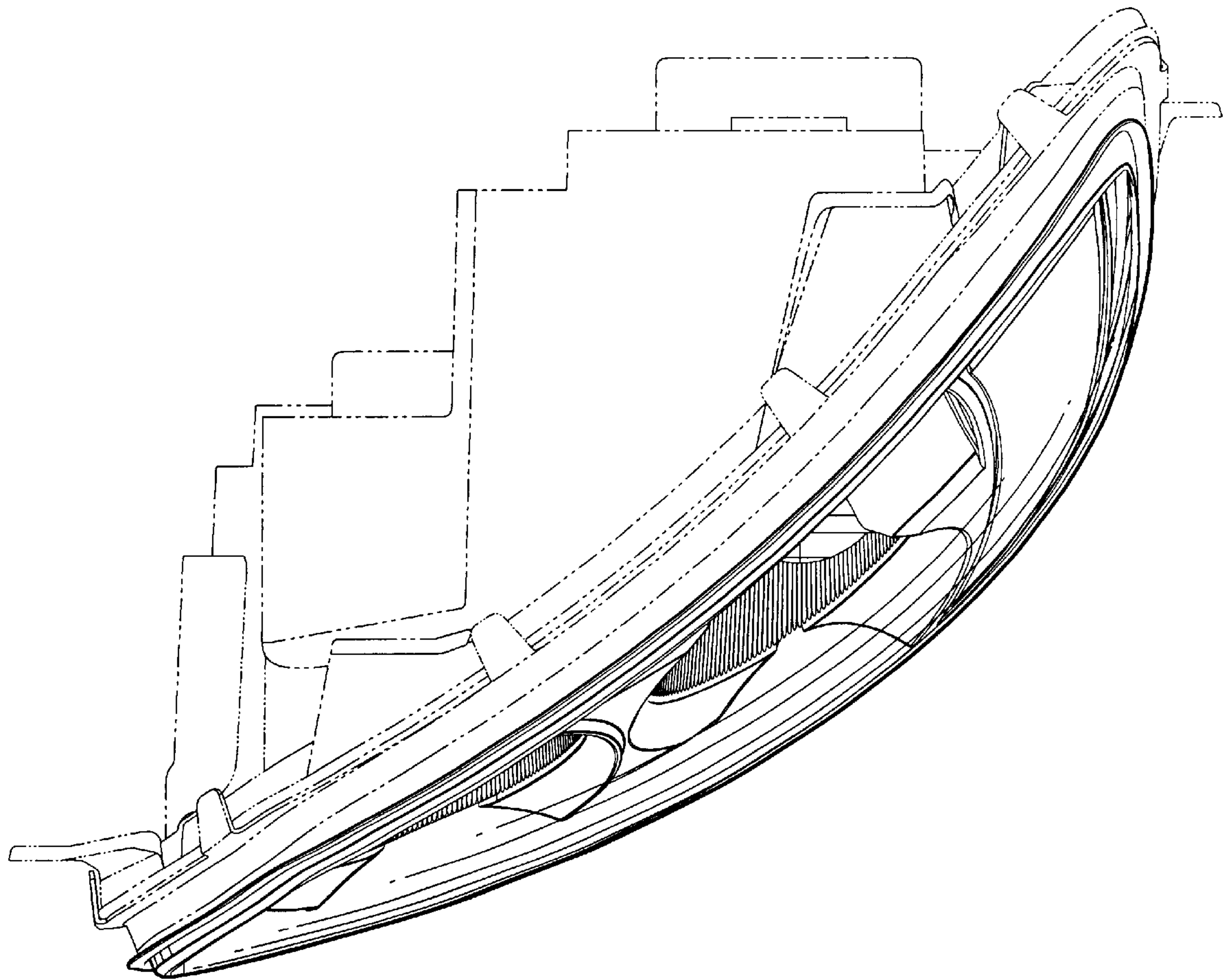
*Fig. 1.*



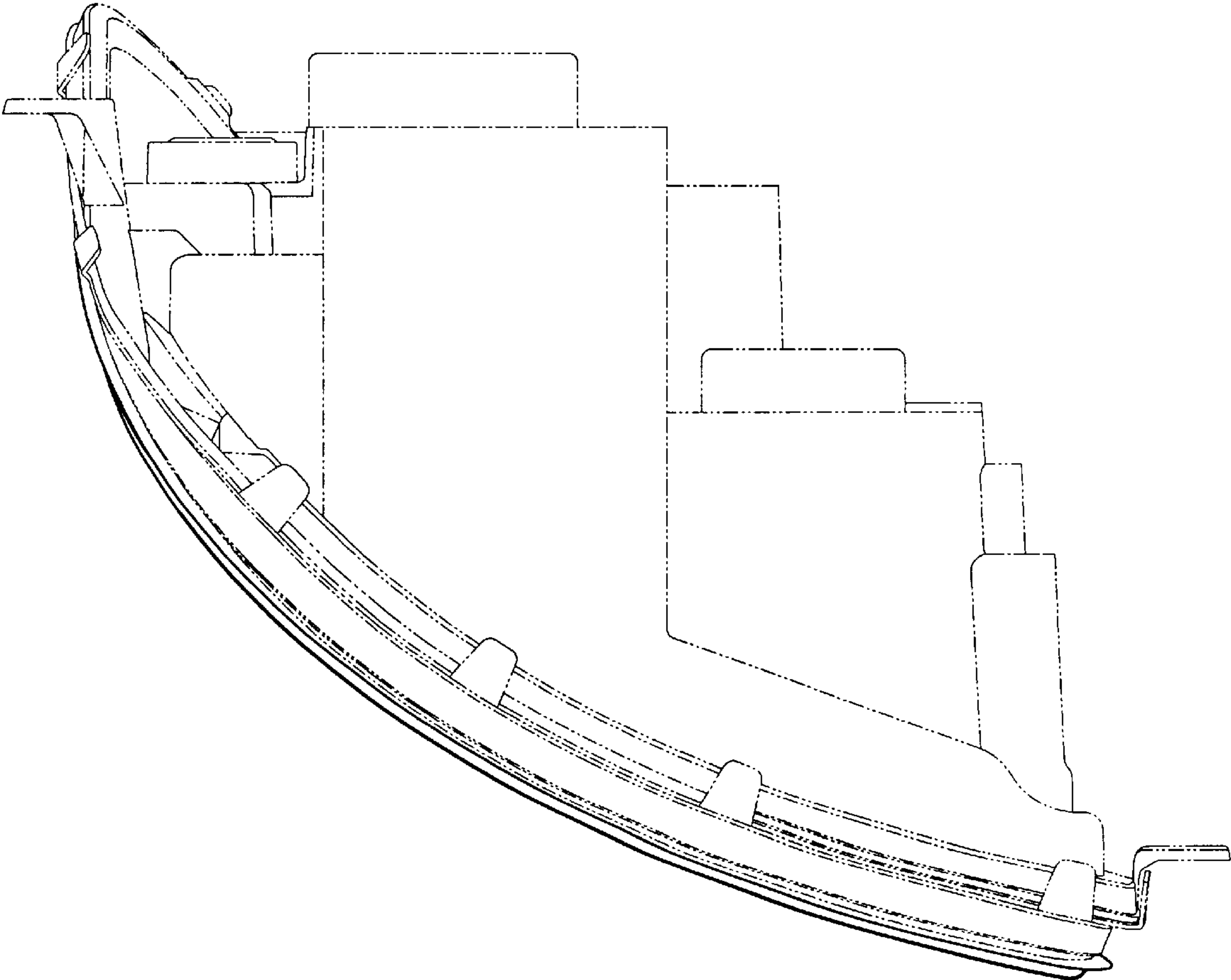
*Fig. 2.*



*Fig. 3.*

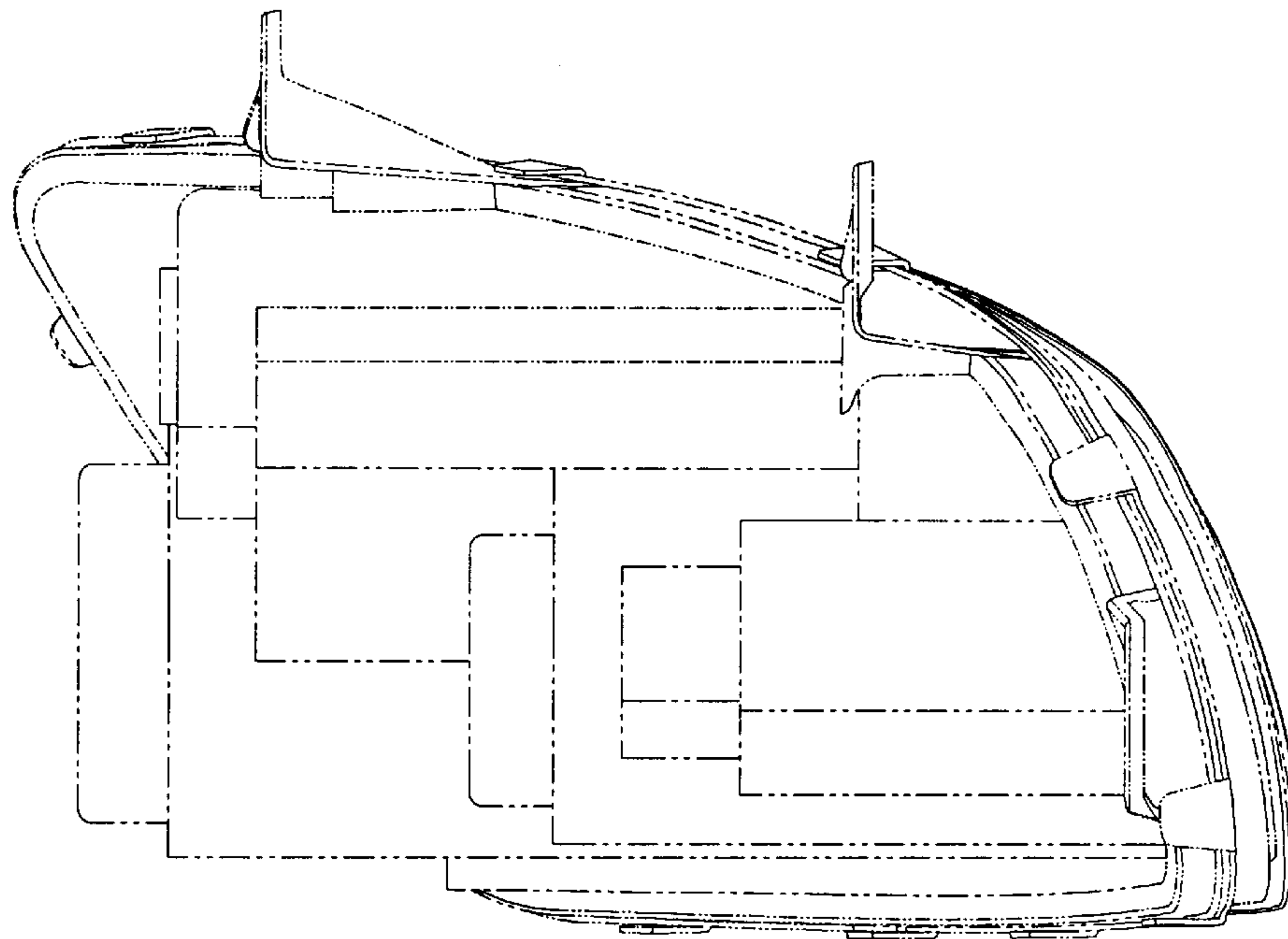


*Fig.4.*

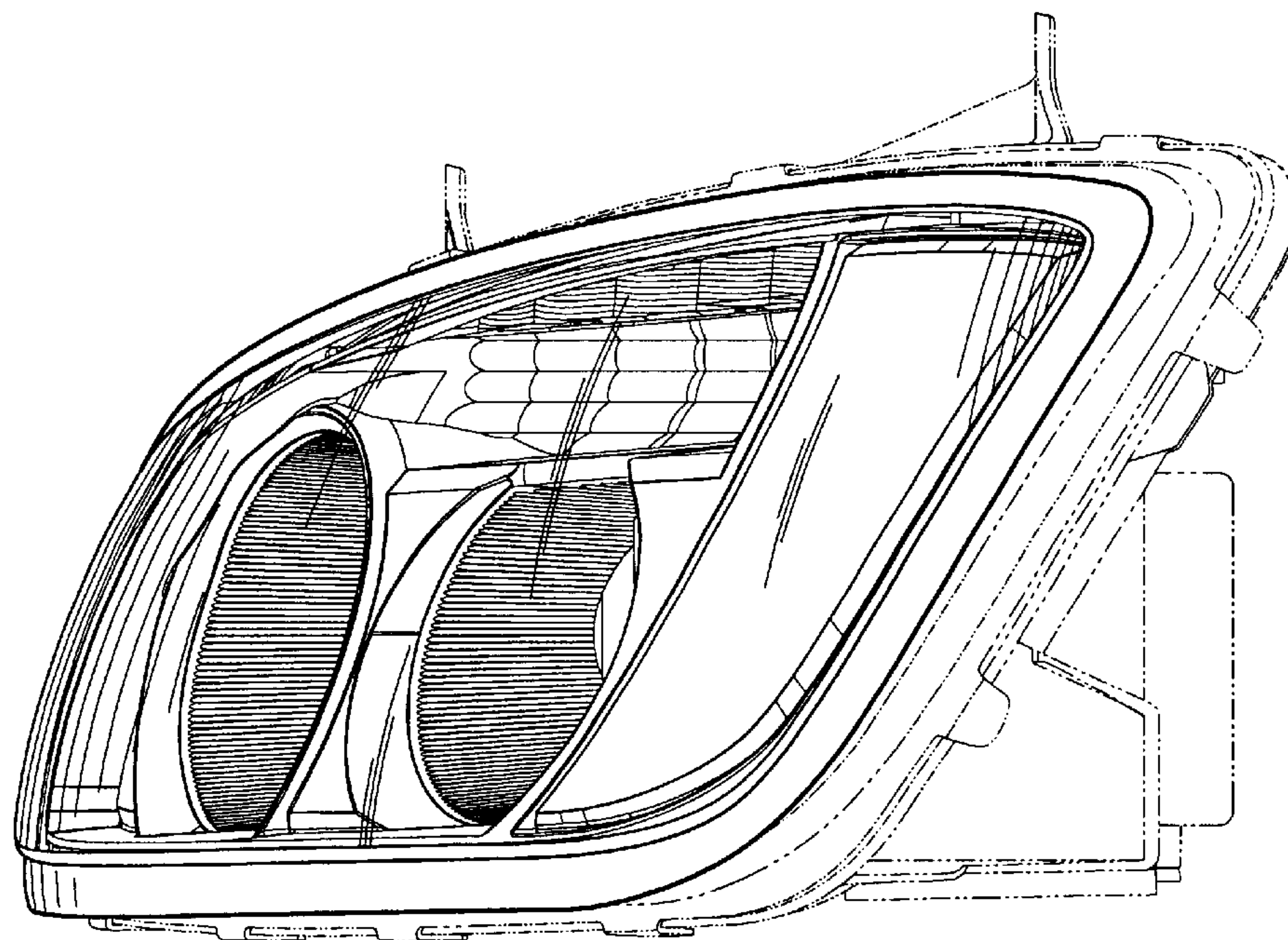


*Fig. 5.*

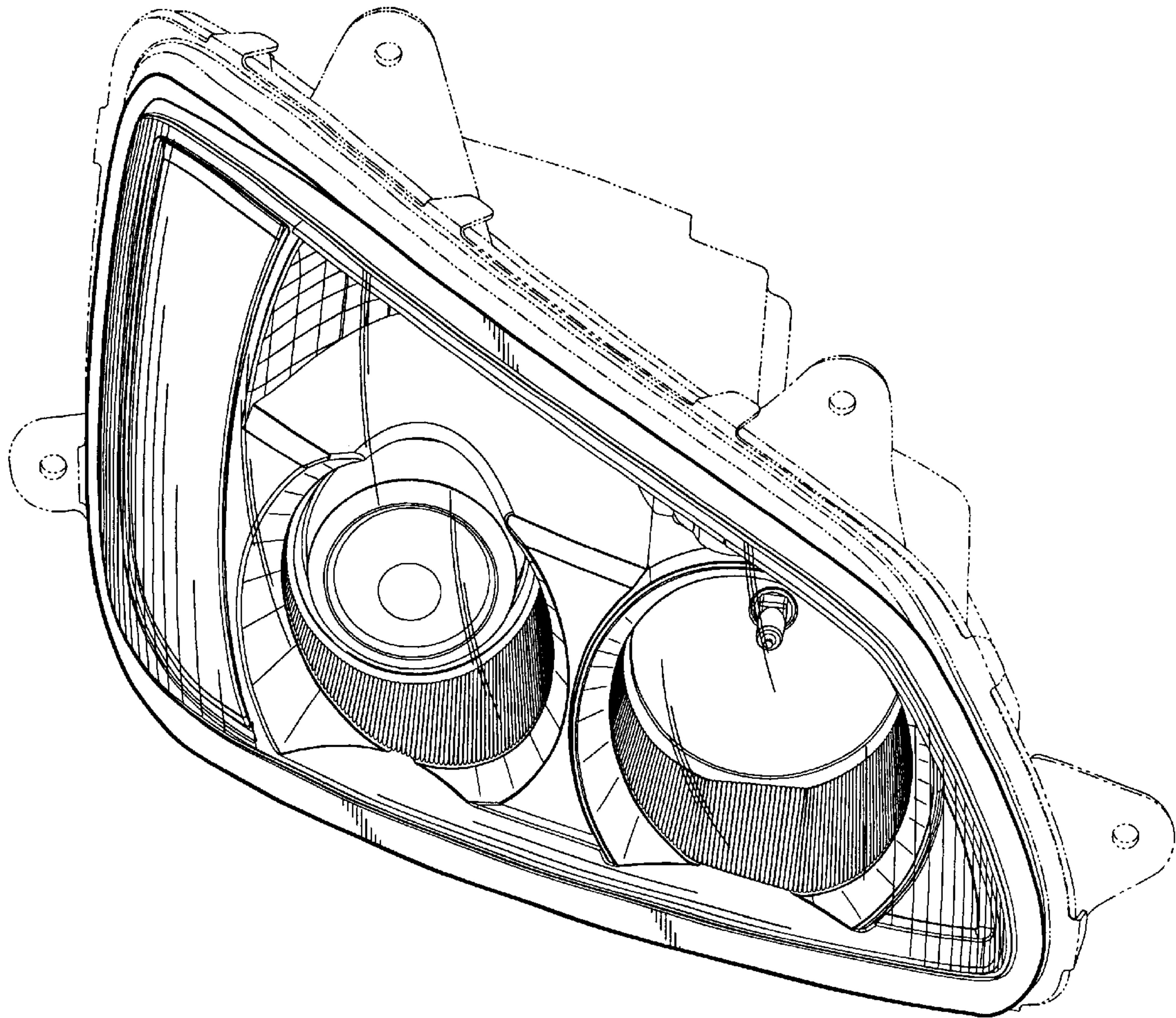




*Fig. 6.*

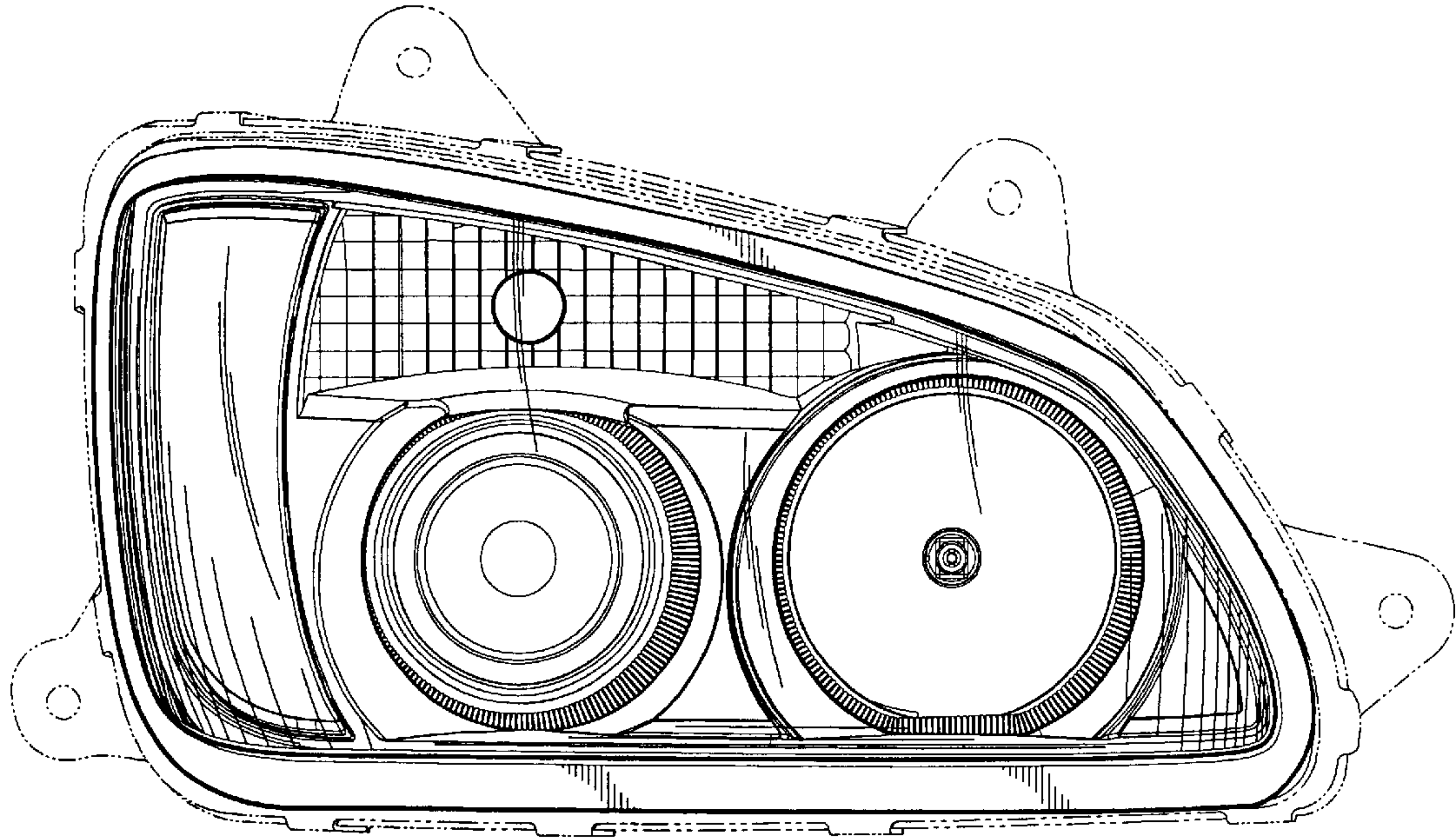


*Fig. 7.*

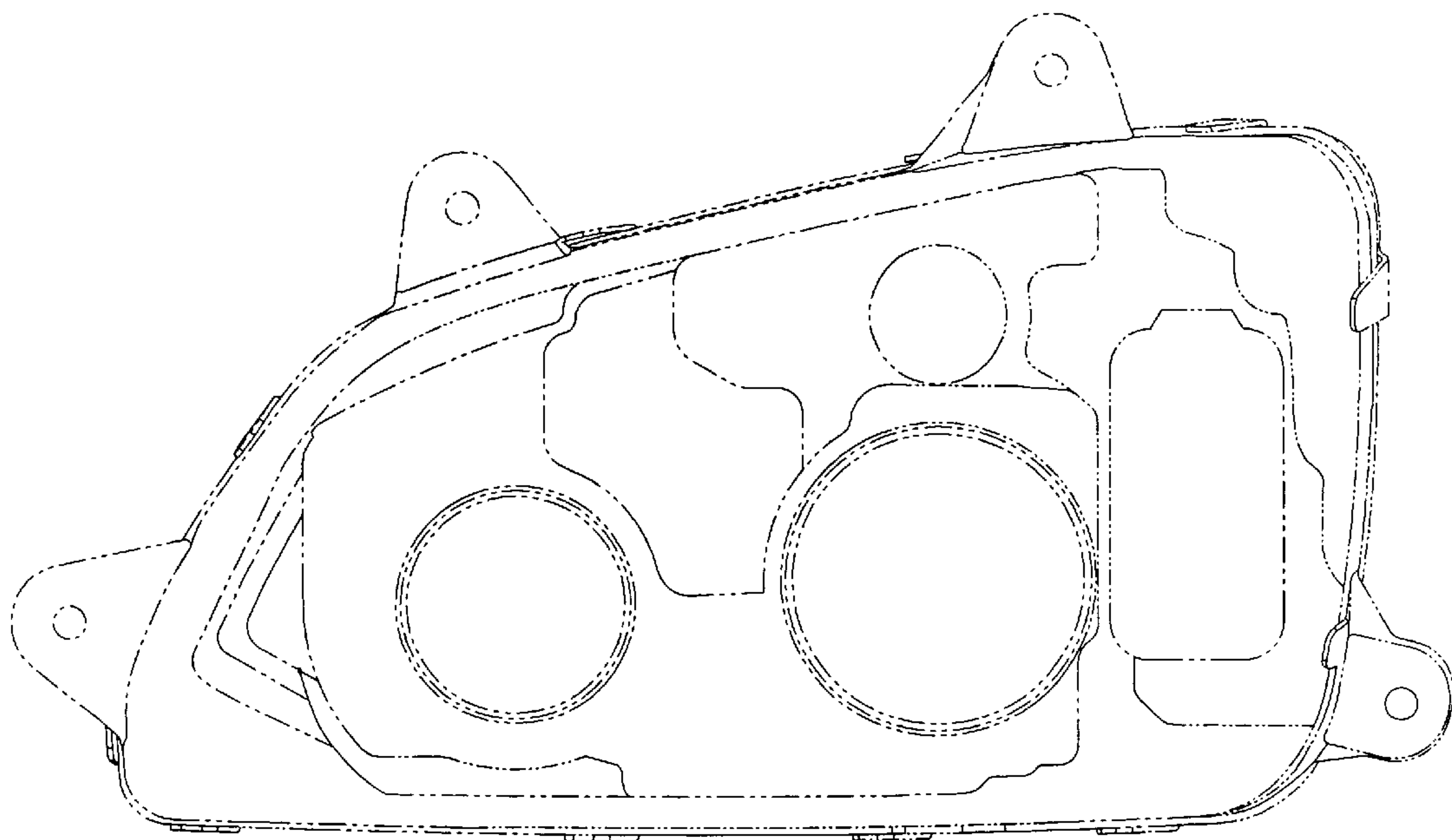


*Fig. 8.*

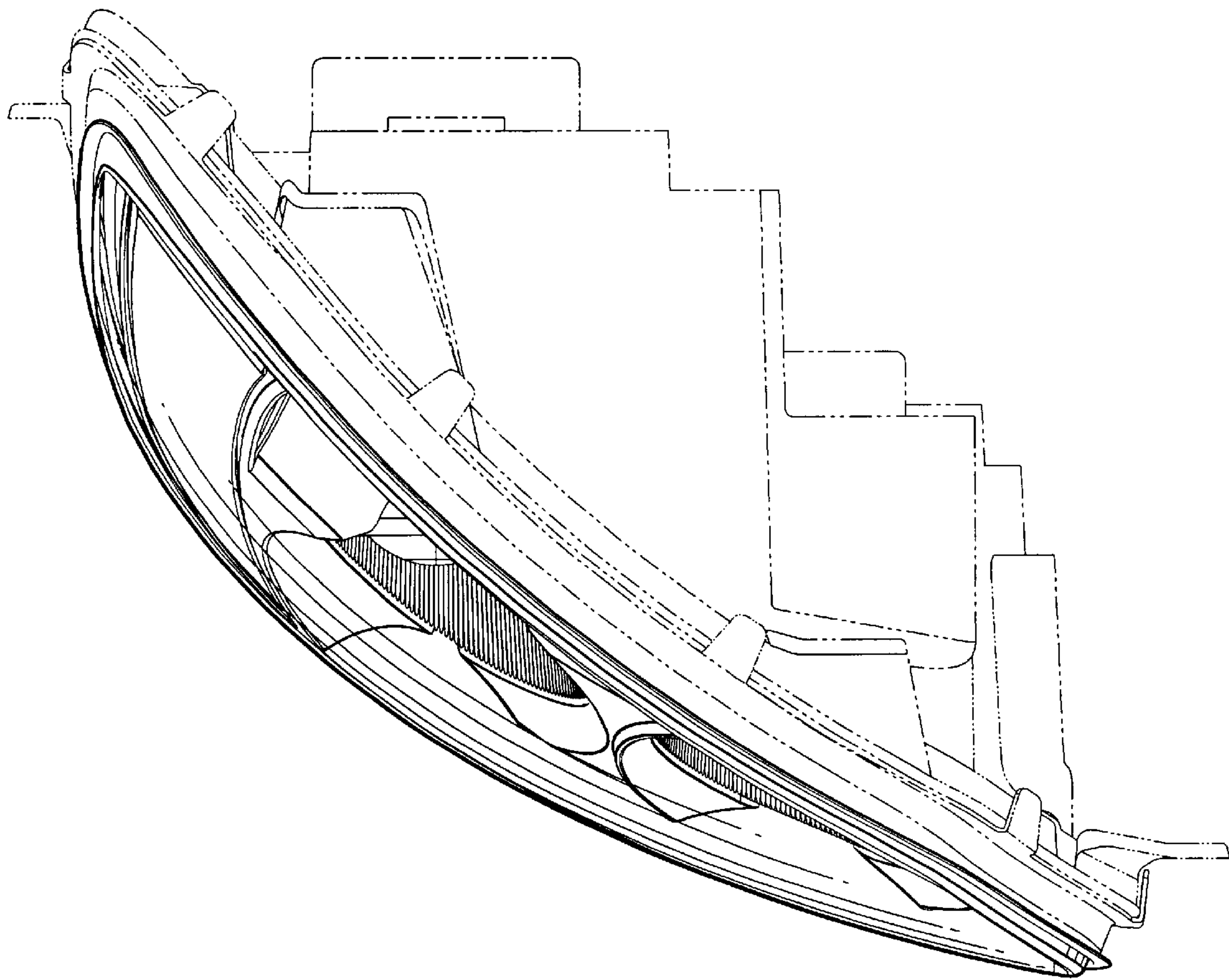




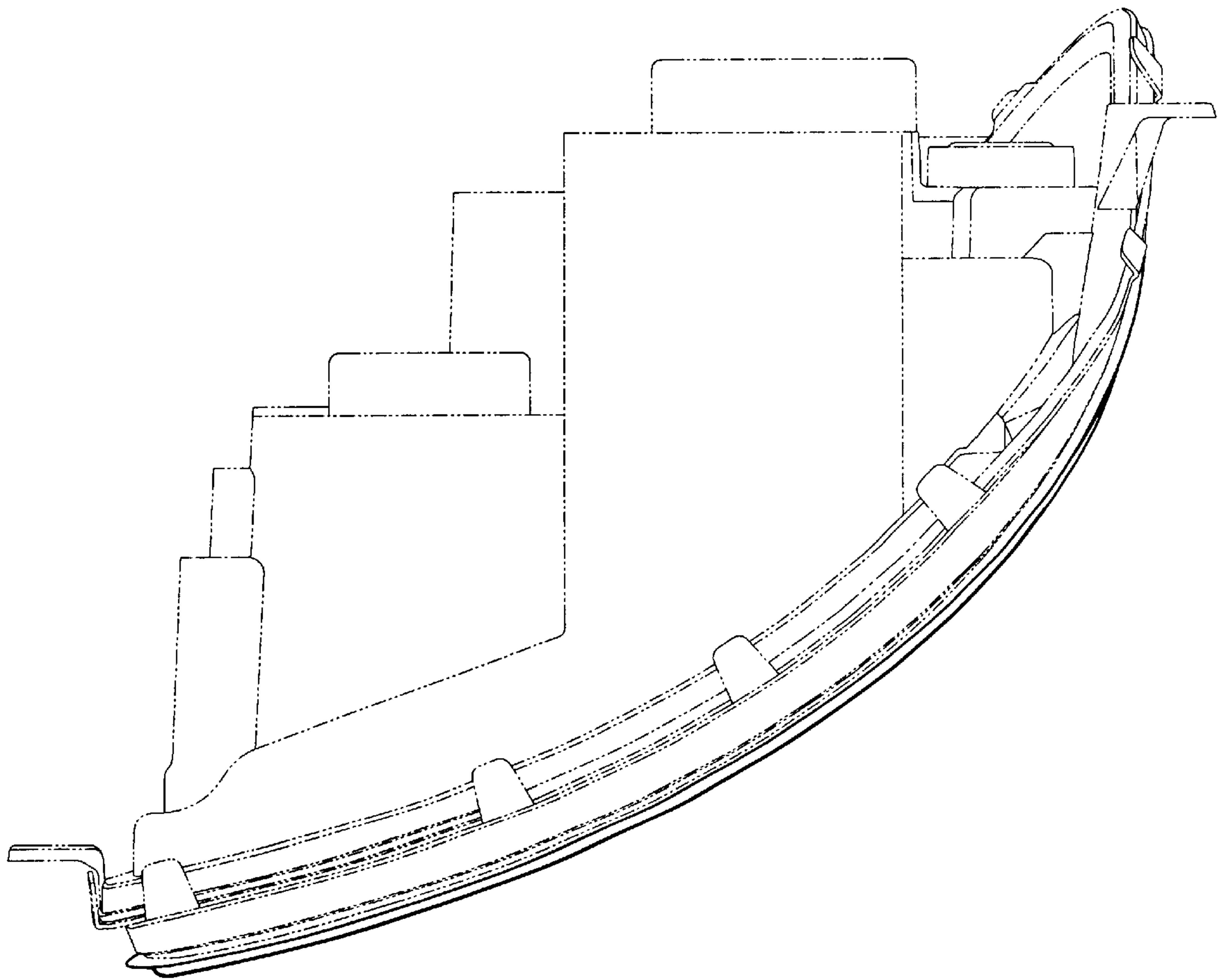
*Fig. 9.*



*Fig. 10.*

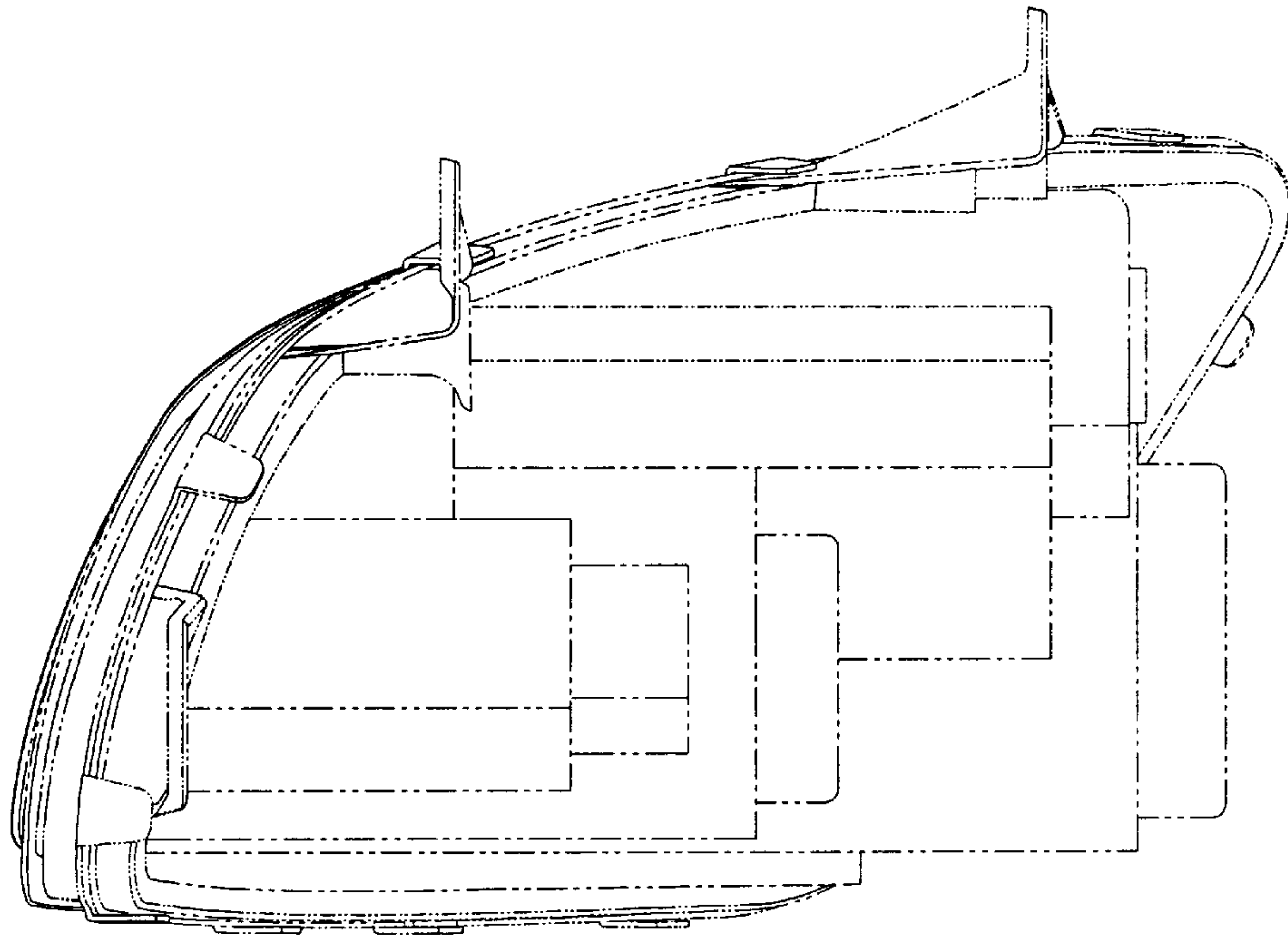


*Fig. 11.*

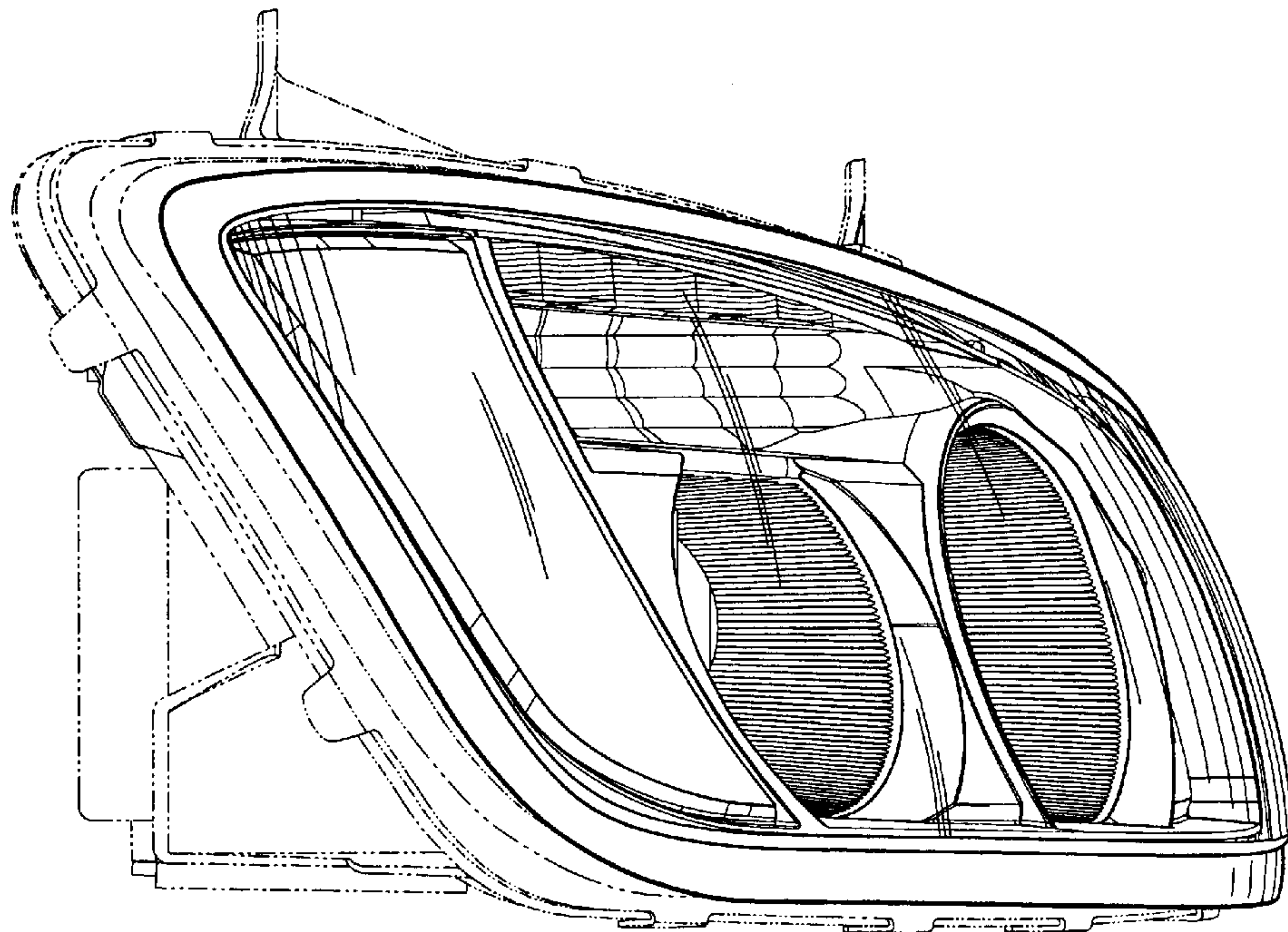


*Fig. 12.*





*Fig. 13.*



*Fig. 14.*



US00D525731C1

(12) **EX PARTE REEXAMINATION CERTIFICATE** (11139th)  
**United States Patent**  
**Hovind et al.**

(10) **Number:** **US D525,731 C1**  
(45) **Certificate Issued:** **Jun. 30, 2017**

(54) **TRUCK HEADLAMP**

(75) **Inventors:** **Steven H Hovind**, Bellevue, WA (US);  
**Gerald Jay Angelo**, Bellevue, WA  
(US); **Daniel R Kieffer**, Kirkland, WA  
(US); **Wayne K Simons**, Kent, WA  
(US); **Daniel Farmer**, Coupeville, WA  
(US); **Richard D Wailes, Jr.**,  
Woodinville, WA (US); **Erik David  
Hjorten**, Everett, WA (US)

(73) **Assignee:** **PACCAR INC**, Bellevue, WA (US)

**Reexamination Request:**

No. 90/013,649, Dec. 9, 2015

**Reexamination Certificate for:**

Patent No.: **Des. 525,731**  
Issued: **Jul. 25, 2006**  
Appl. No.: **29/238,135**  
Filed: **Sep. 12, 2005**

(51) **LOC (10) Cl.** ..... **26-06**

(52) **U.S. Cl.**

USPC ..... **D26/28**

(58) **Field of Classification Search**

USPC ..... D26/28, 29, 34-36, 118, 120, 124, 139;  
362/459-468, 475, 476, 507, 538

CPC ..... A63C 2203/14; B60Q 1/11; B60Q 1/12;  
B60Q 1/18; B60Q 1/007; B60Q 1/0683;  
B60Q 1/0686; B60Q 11/00; B60Q  
2300/112; B60Q 2300/122; F21S 48/145;  
F21S 48/1154; F21S 48/1159; F21S  
48/1186

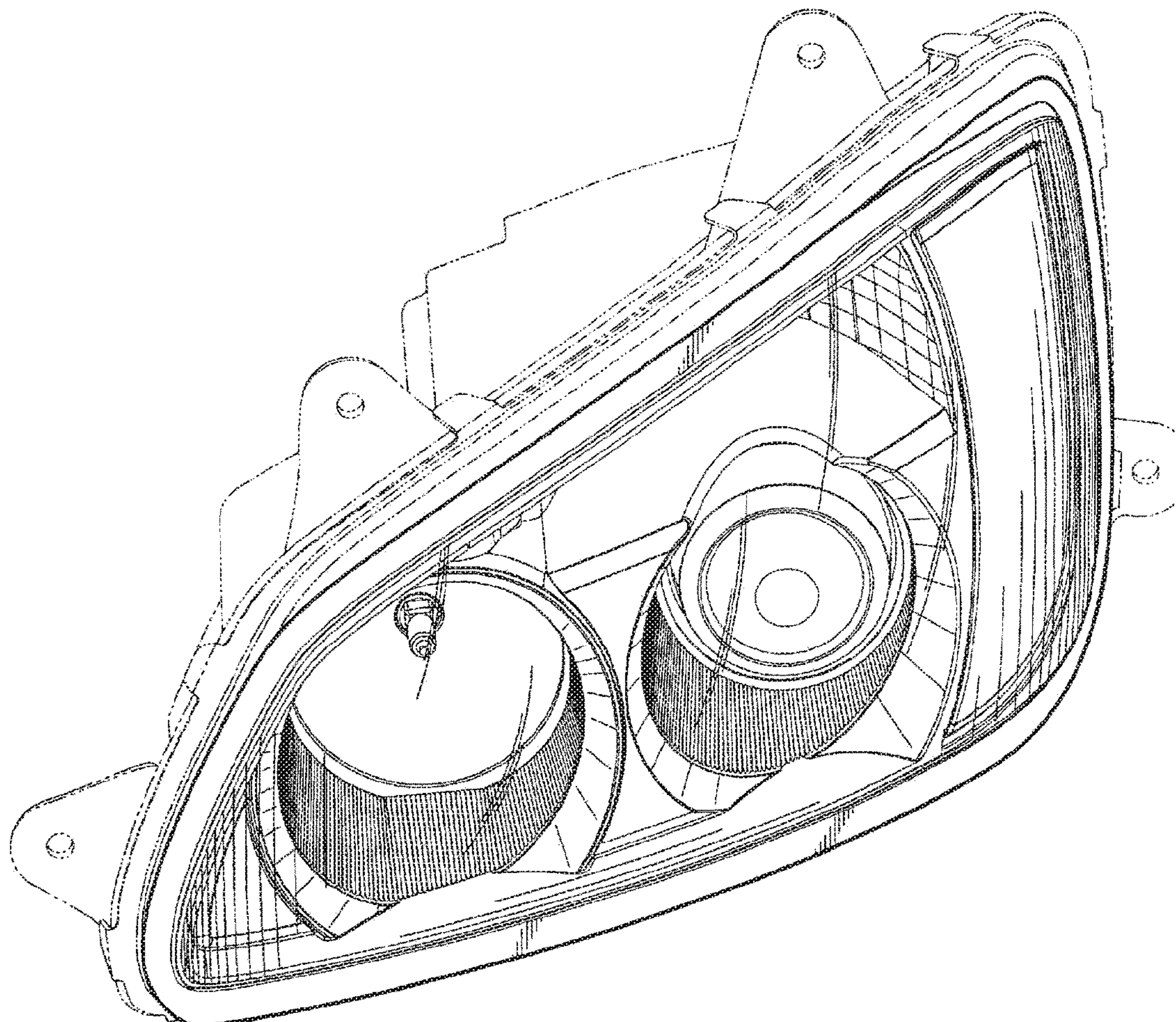
See application file for complete search history.

(56)

**References Cited**

To view the complete listing of prior art documents cited during the proceeding for Reexamination Control Number 90/013,649, please refer to the USPTO's public Patent Application Information Retrieval (PAIR) system under the Display References tab.

*Primary Examiner* — Keli L Hill



**1**  
**EX PARTE**  
**REEXAMINATION CERTIFICATE**

NO AMENDMENTS HAVE BEEN MADE TO 5  
THE PATENT

AS A RESULT OF REEXAMINATION, IT HAS BEEN  
DETERMINED THAT:

The patentability of claim 1 is confirmed. 10

\* \* \* \* \*