

US00D525664S

(12) **United States Design Patent**
Cole

(10) **Patent No.:** **US D525,664 S**

(45) **Date of Patent:** **** Jul. 25, 2006**

(54) **GAMING MACHINE DOOR**

(76) Inventor: **Joseph W. Cole**, 7104 Via Campanile Ave., Las Vegas, NV (US) 89131

(**) Term: **14 Years**

(21) Appl. No.: **29/214,437**

(22) Filed: **Oct. 1, 2004**

(51) **LOC (8) Cl.** **21-03**

(52) **U.S. Cl.** **D21/369**

(58) **Field of Classification Search** D21/325,
D21/329, 369-371, 374, 385; 273/138.1;
463/16-17, 20, 25, 42, 46-47
See application file for complete search history.

(56) **References Cited**

U.S. PATENT DOCUMENTS

| | | | |
|--------------|-----------|------------------|---------------|
| 4,440,457 A | 4/1984 | Fogelman et al. | |
| 5,113,990 A | 5/1992 | Gabrius et al. | |
| D333,164 S | 2/1993 | Kraft et al. | |
| D373,809 S | 9/1996 | Hirato | |
| D381,697 S | * 7/1997 | Brettschneider | D21/370 |
| 5,695,402 A | 12/1997 | Stupak | |
| 5,826,882 A | 10/1998 | Ward | |
| 6,068,101 A | 5/2000 | Dickenson et al. | |
| D428,062 S | 7/2000 | Hayashi | |
| 6,135,884 A | 10/2000 | Hedrick et al. | |
| 6,164,645 A | 12/2000 | Weiss | |
| 6,201,703 B1 | 3/2001 | Yamada et al. | |
| D439,931 S | 4/2001 | Yamaguchi | |
| D446,252 S | * 8/2001 | Yamaguchi | D21/325 |
| 6,334,612 B1 | 1/2002 | Wurz et al. | |
| 6,475,087 B1 | 11/2002 | Cole | |
| 6,641,484 B1 | 11/2003 | Oles et al. | |
| D489,417 S | * 5/2004 | Munoz et al. | D21/370 |
| D495,755 S | * 9/2004 | Wurz et al. | D21/370 |
| D498,267 S | * 11/2004 | Crouch | D21/370 |
| 6,860,814 B1 | * 3/2005 | Cole | 463/46 |

2004/0224776 A1 * 11/2004 Nagano 463/46

* cited by examiner

Primary Examiner—Sandra L. Morris

(74) *Attorney, Agent, or Firm*—Weide & Miller, Ltd.

(57) **CLAIM**

The ornamental design for a gaming machine door, as shown and described.

DESCRIPTION

FIG. 1 is a perspective view of a gaming machine door in accordance with a first embodiment of the present invention. The gaming machine housing, buttons, coin acceptor, bumper and media reader shown in broken lines illustrate an environment of the claimed design and do not form a portion of the claimed design.

FIG. 2 is a top view of the gaming machine door illustrated in FIG. 1.

FIG. 3 is a side view of the gaming machine door illustrated in FIG. 1.

FIG. 4 is a front view of the gaming machine door illustrated in FIG. 1.

FIG. 5 is a bottom view of the gaming machine door illustrated in FIG. 1.

FIG. 6 is a perspective view of a gaming machine door in accordance with a second embodiment of the present invention, the gaming machine door including a coin tray. The gaming machine housing, buttons, coin acceptor, media reader and speakers shown in broken lines illustrate an environment of the claimed design and do not form a portion of the claimed design.

FIG. 7 is a top view of the gaming machine door illustrated in FIG. 6.

FIG. 8 is a side view of the gaming machine door illustrated in FIG. 6.

FIG. 9 is a front view of the gaming machine door illustrated in FIG. 6; and,

FIG. 10 is a bottom view of the gaming machine door illustrated in FIG. 6.

1 Claim, 4 Drawing Sheets

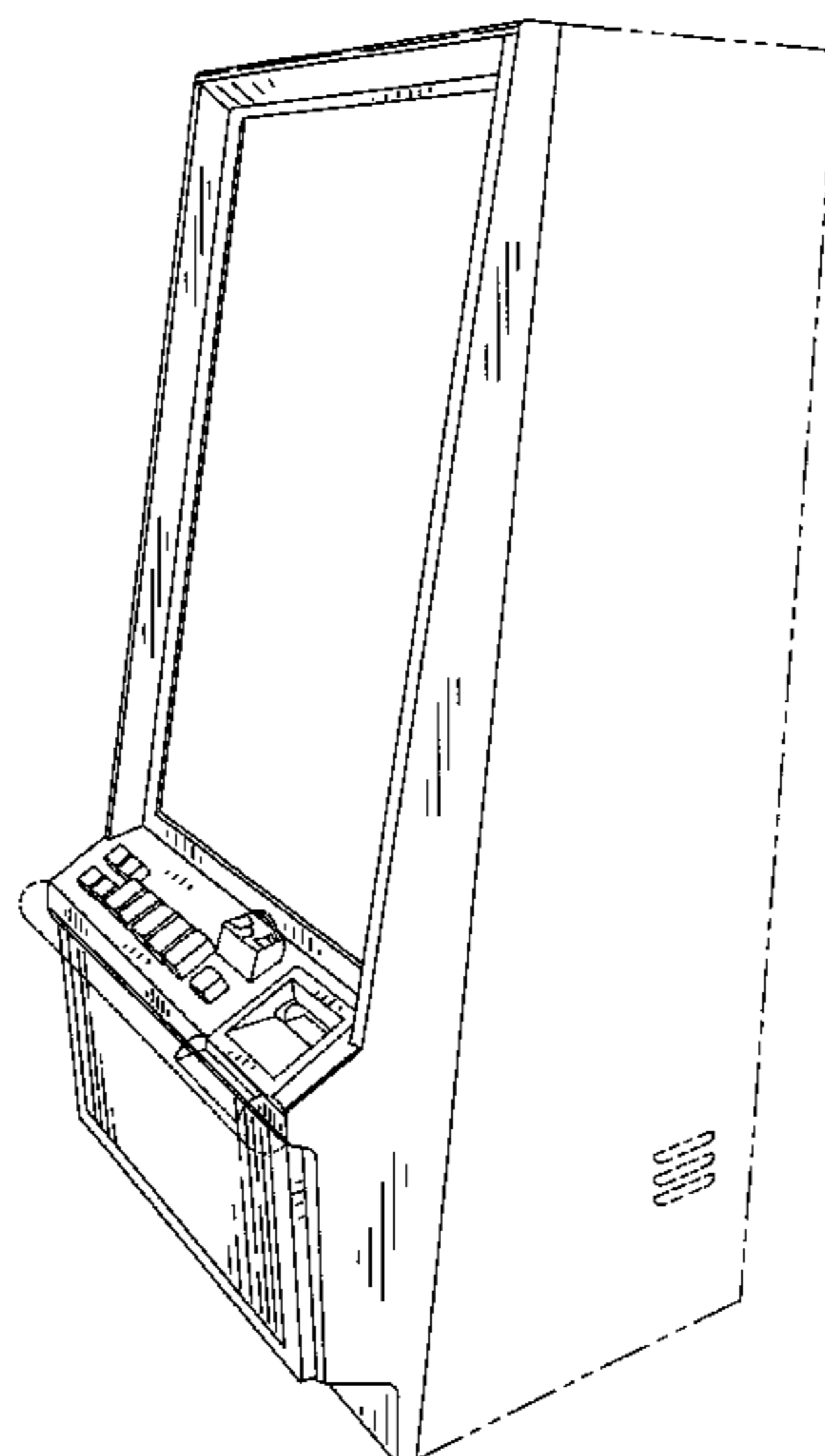

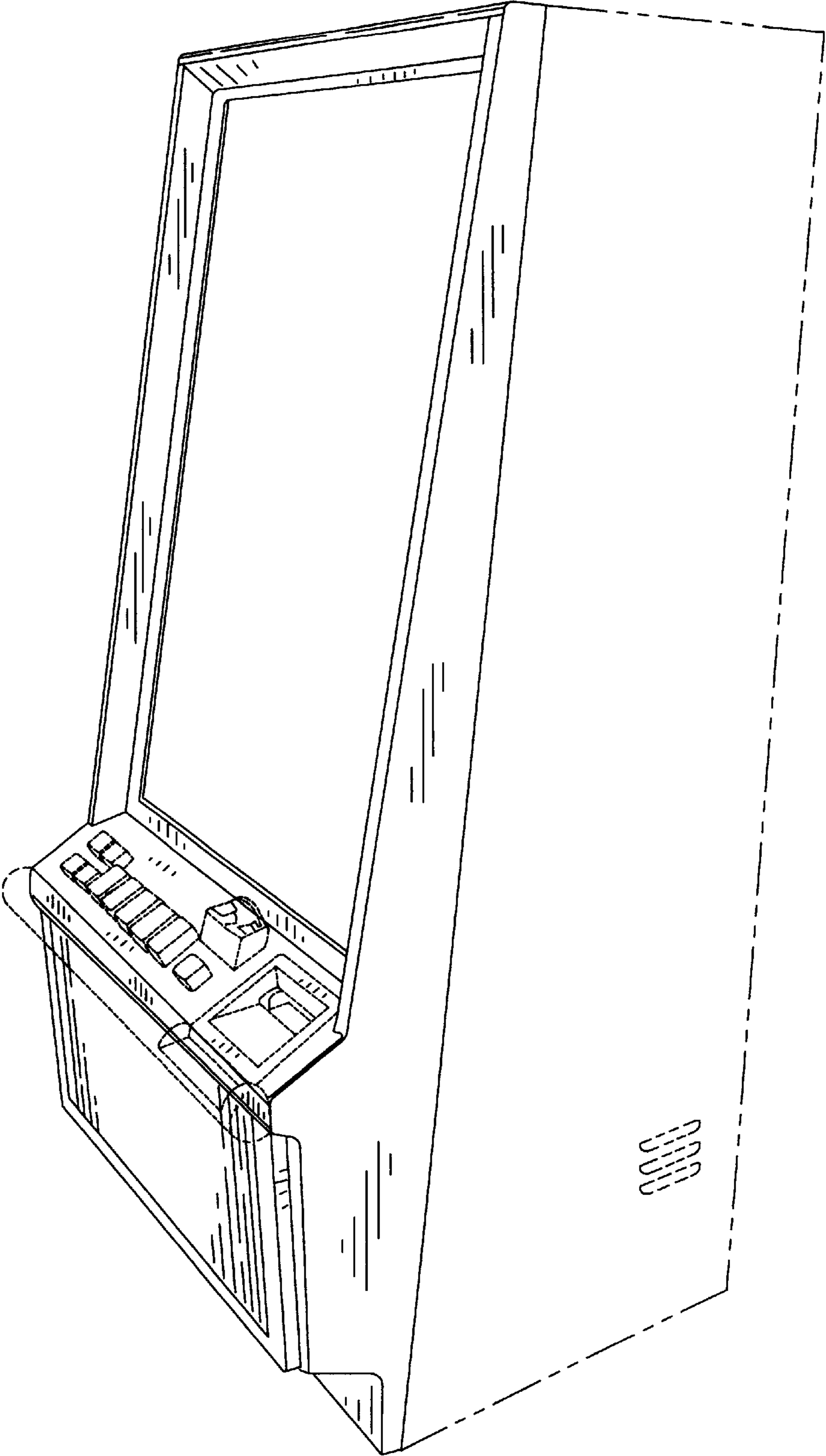

Fig. 1

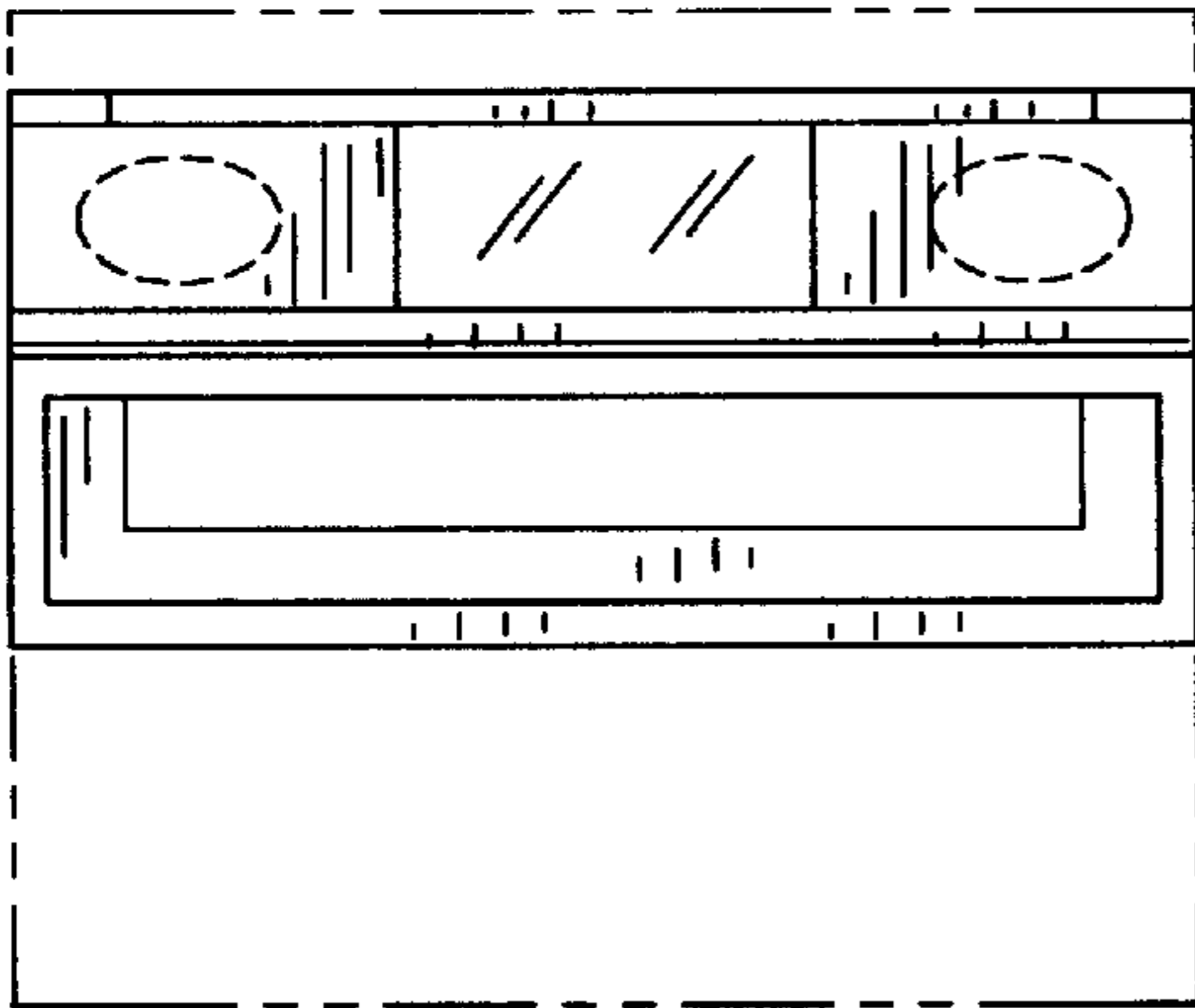

Fig. 5

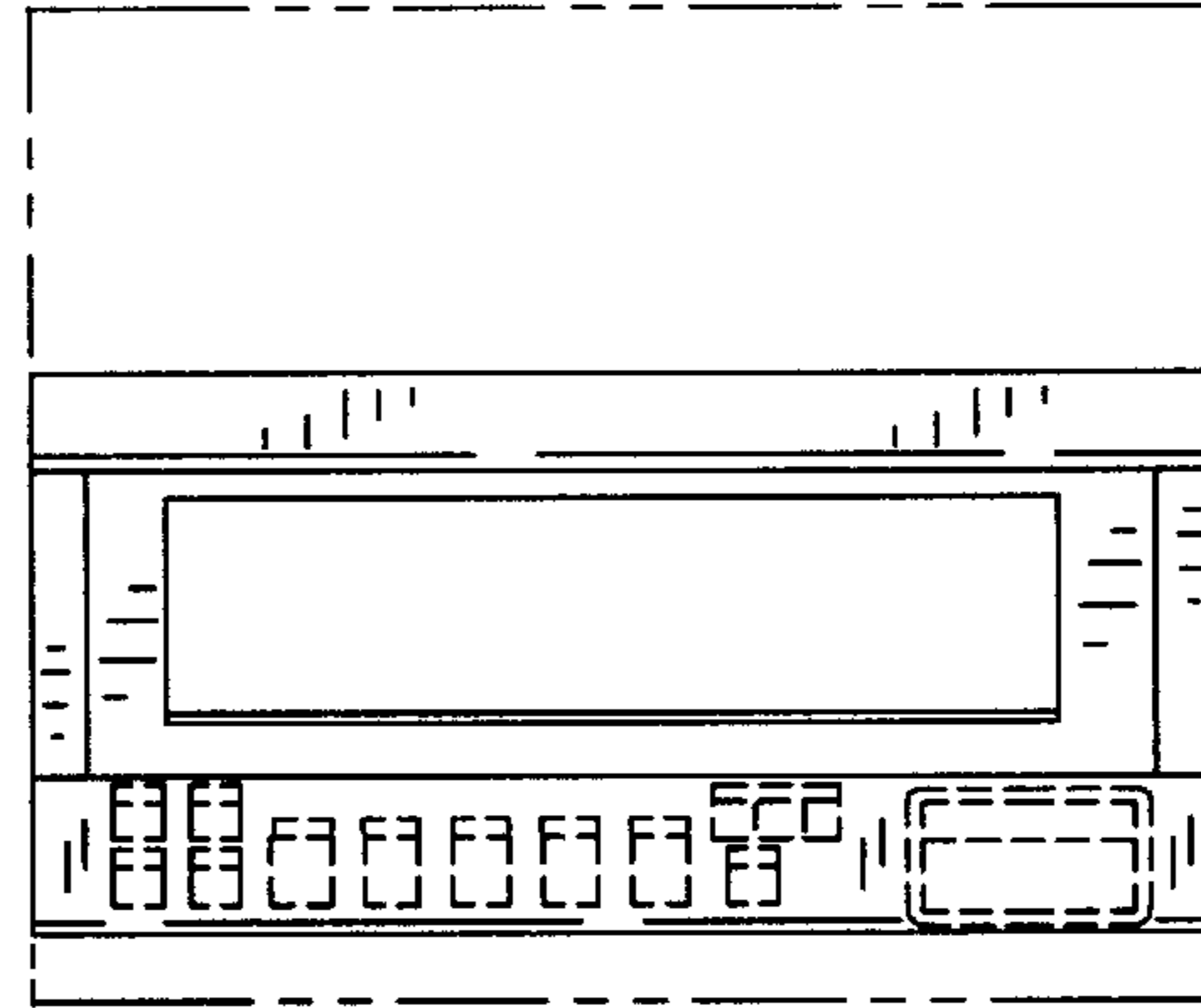

Fig. 2

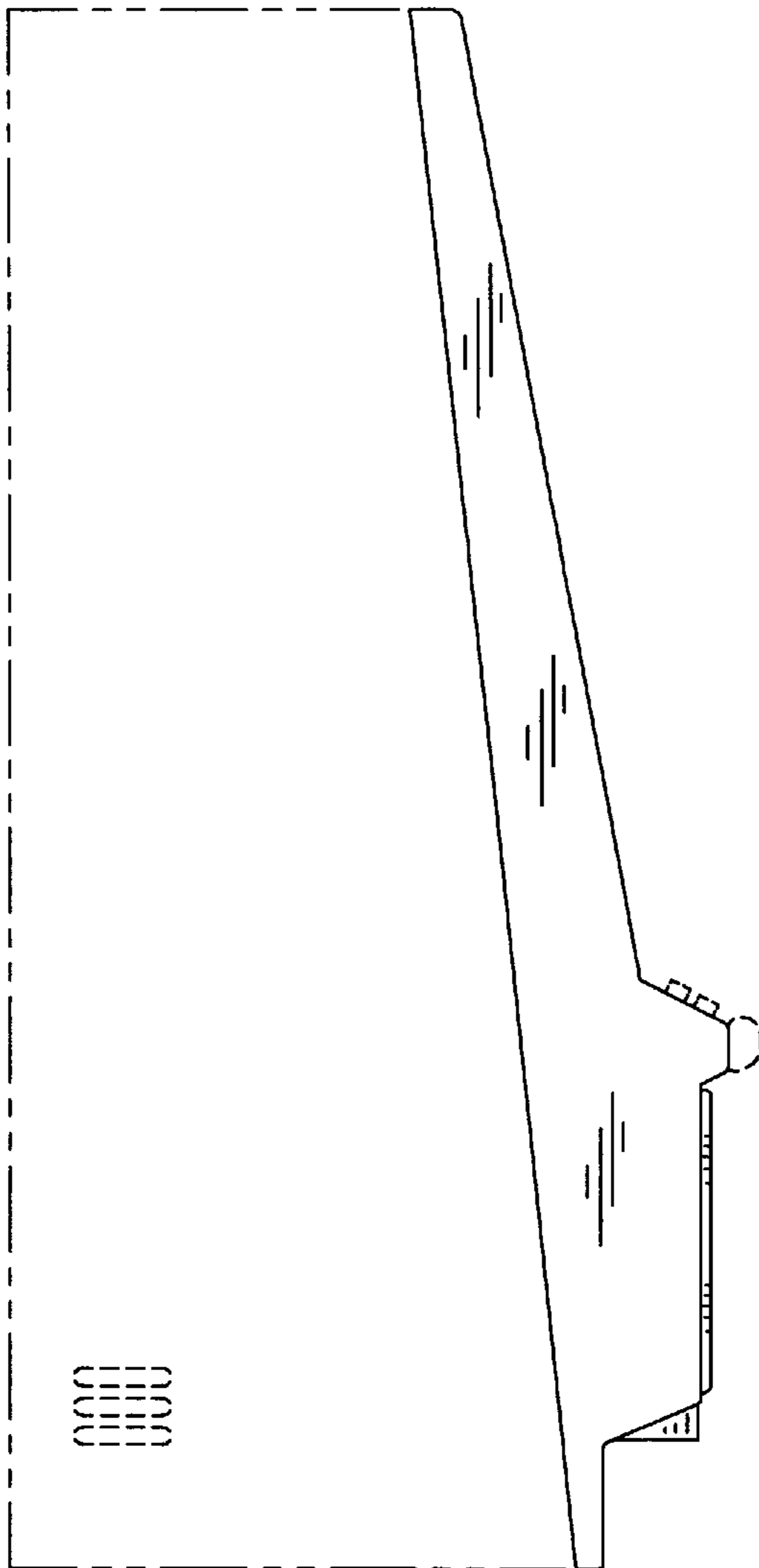

Fig. 3

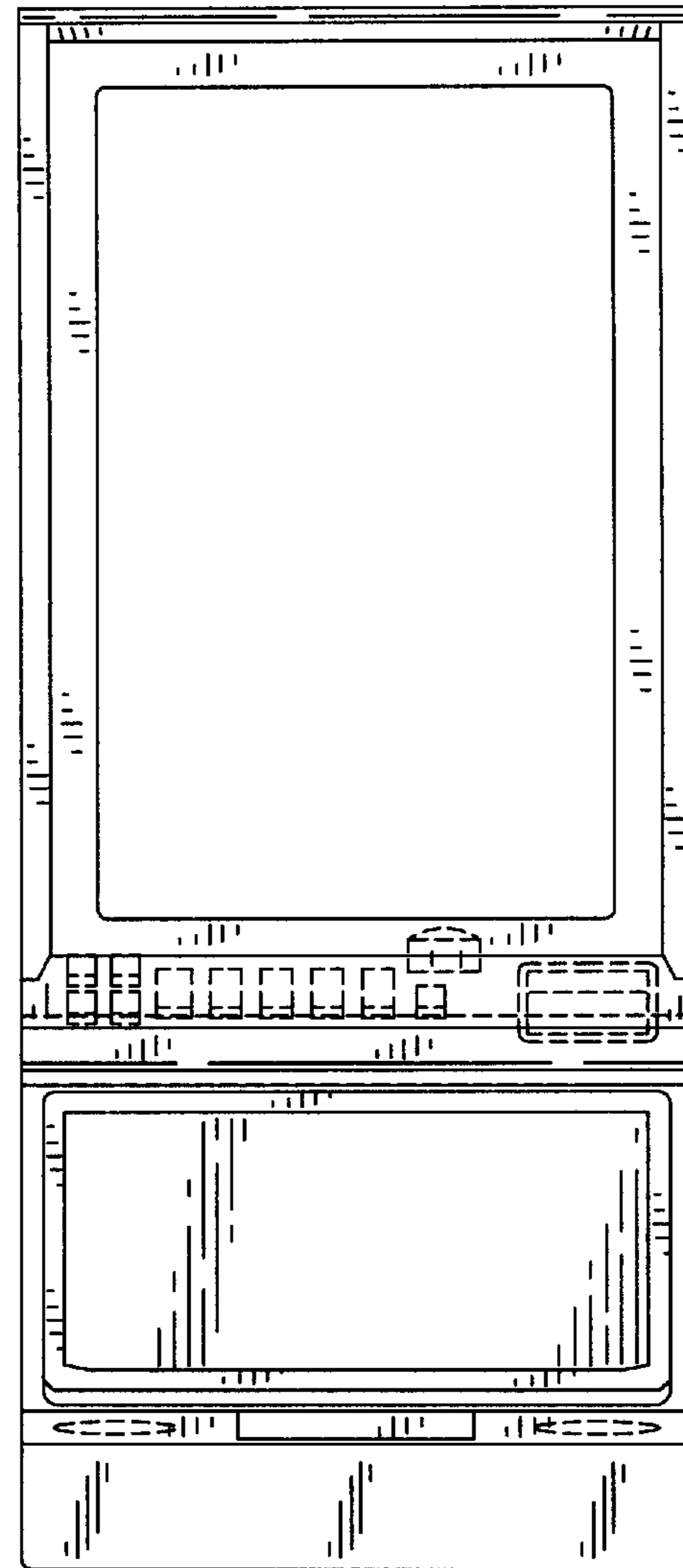

Fig. 4

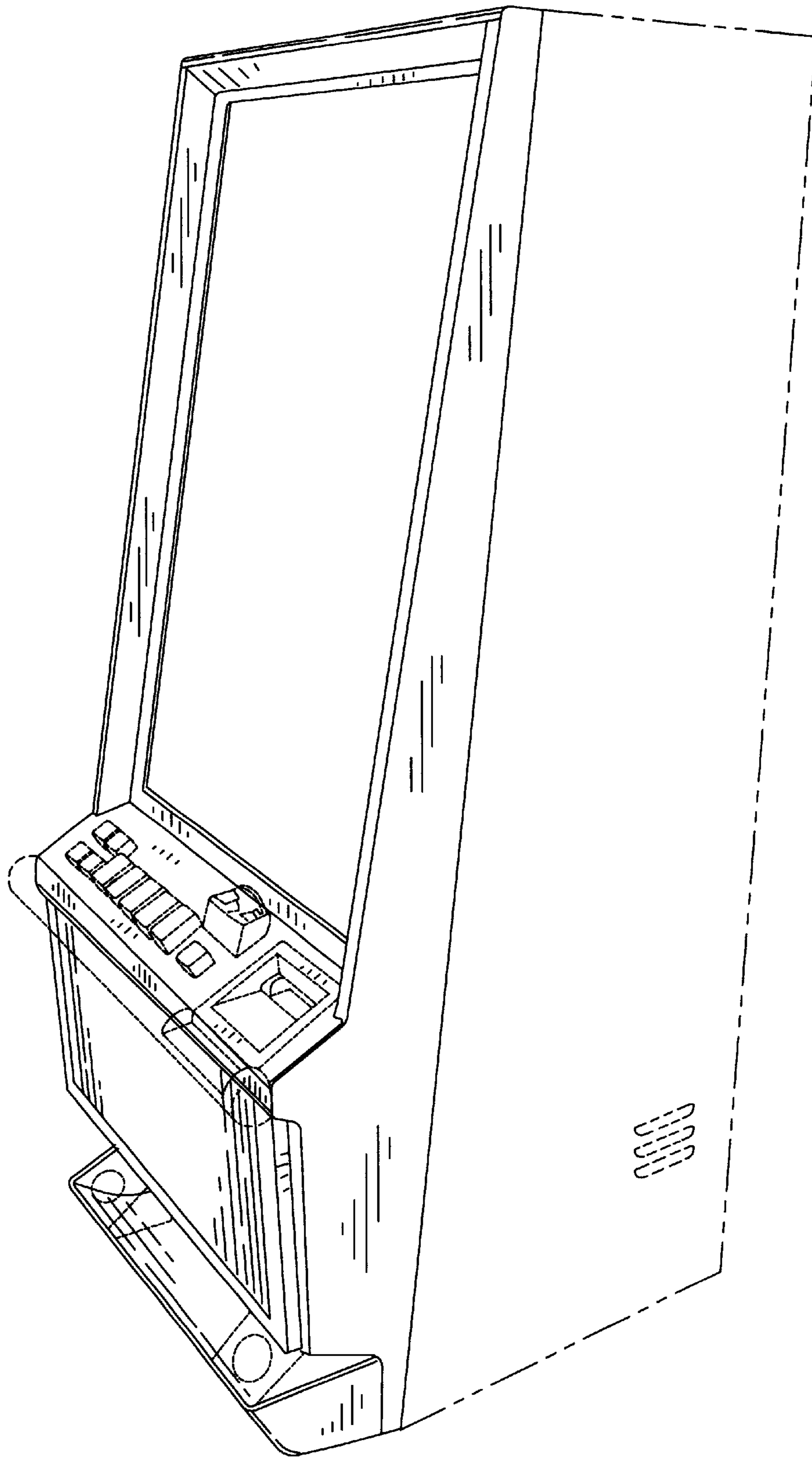

Fig. 6

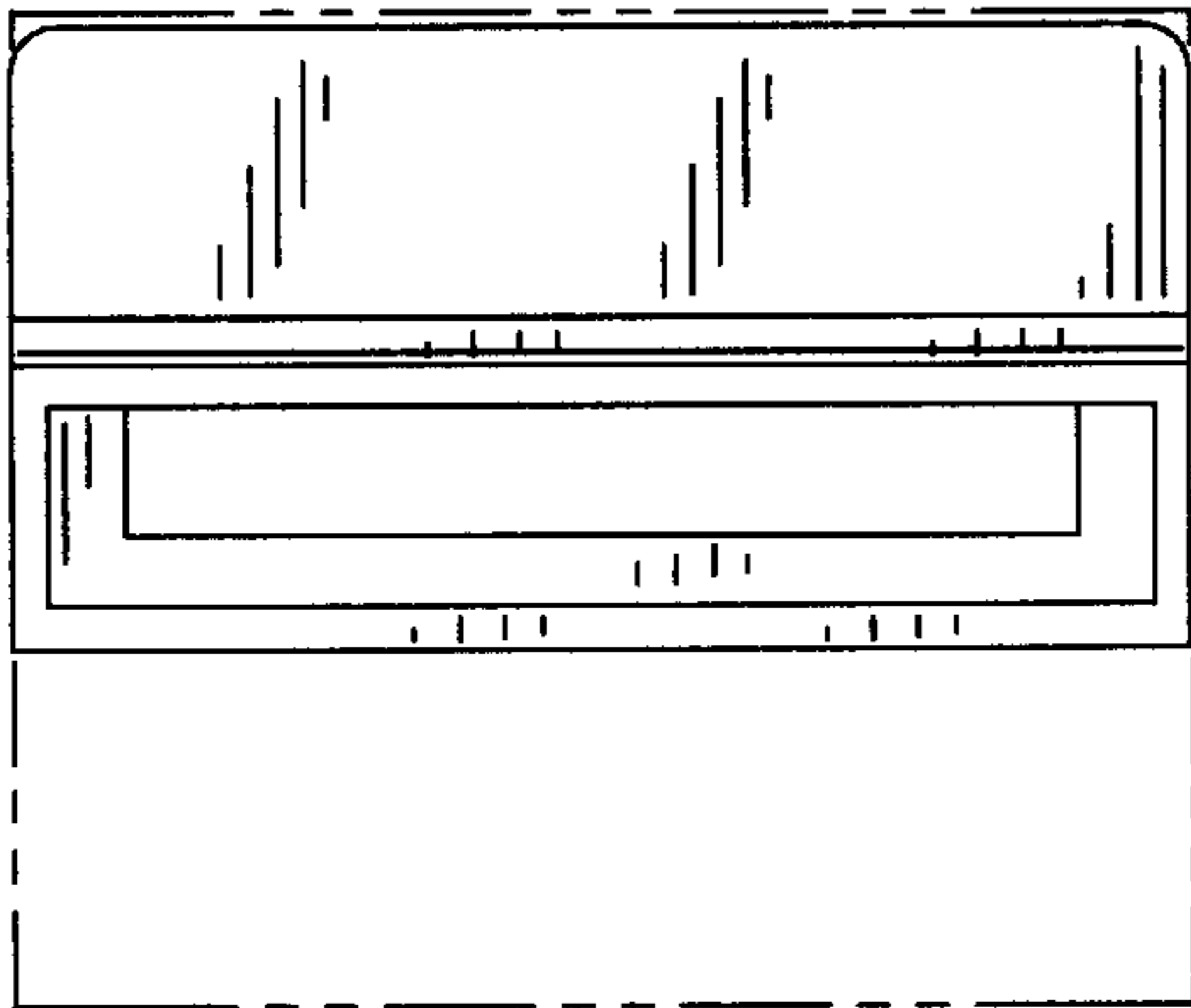

Fig. 10

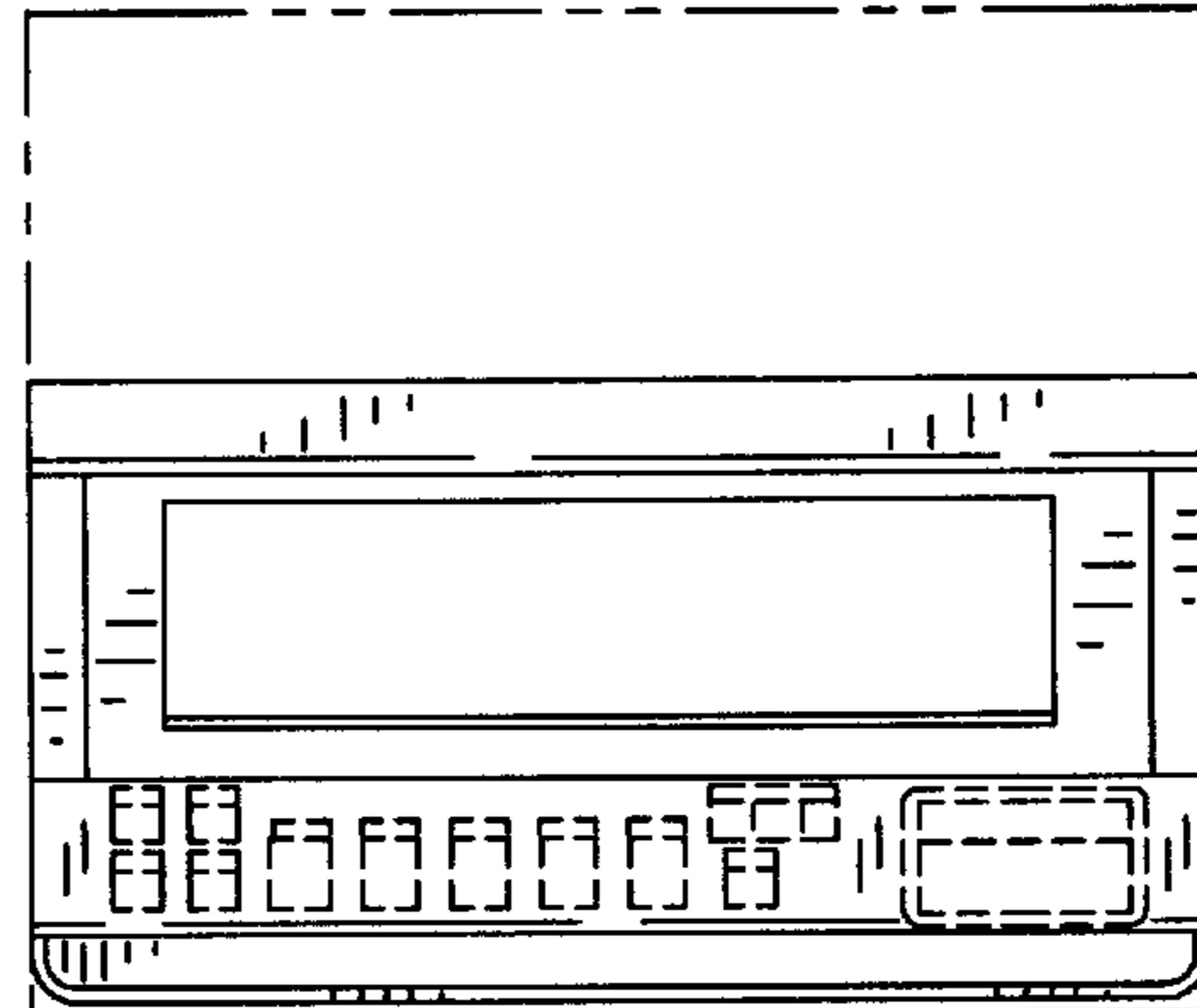

Fig. 7

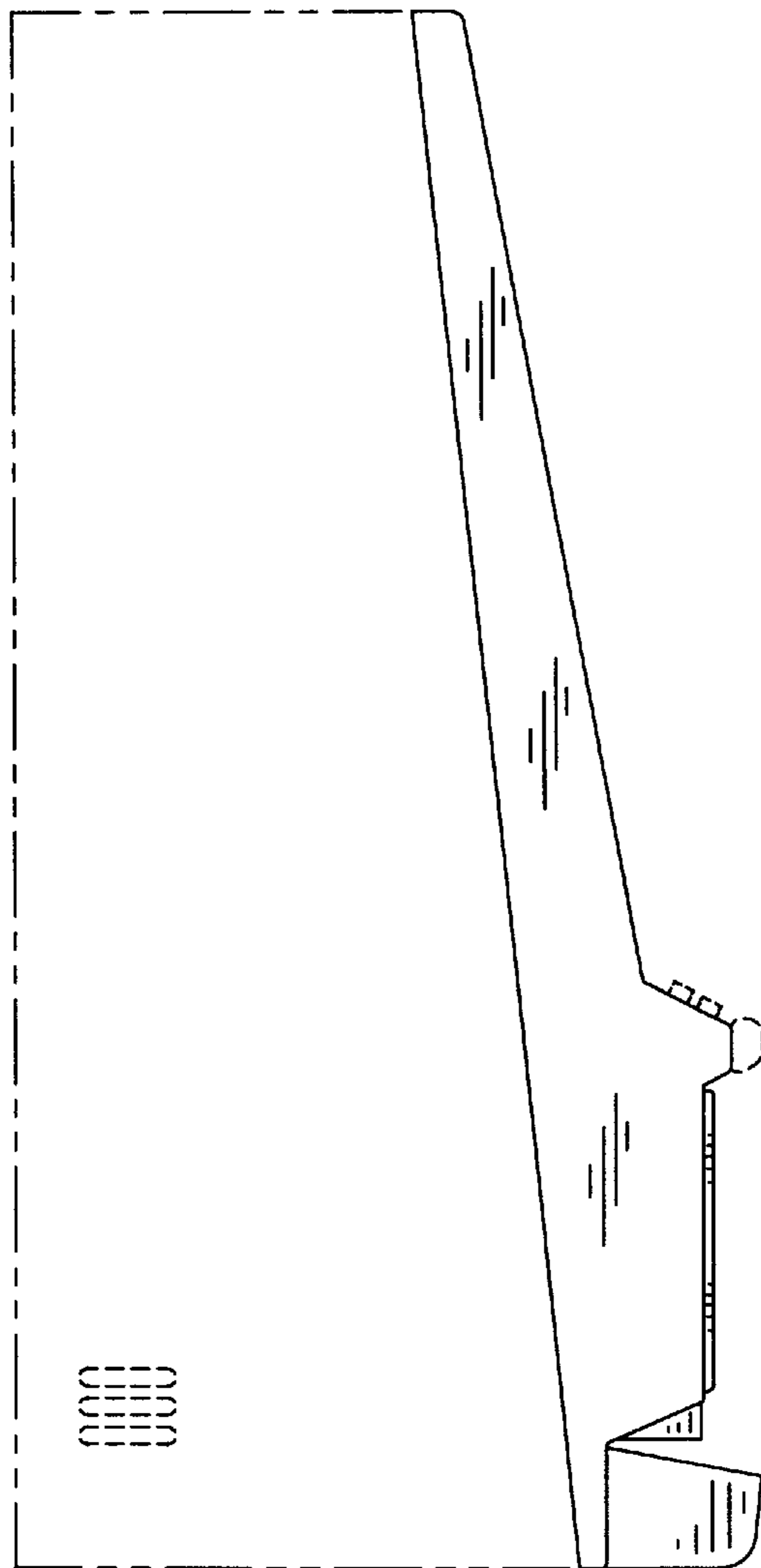

Fig. 8

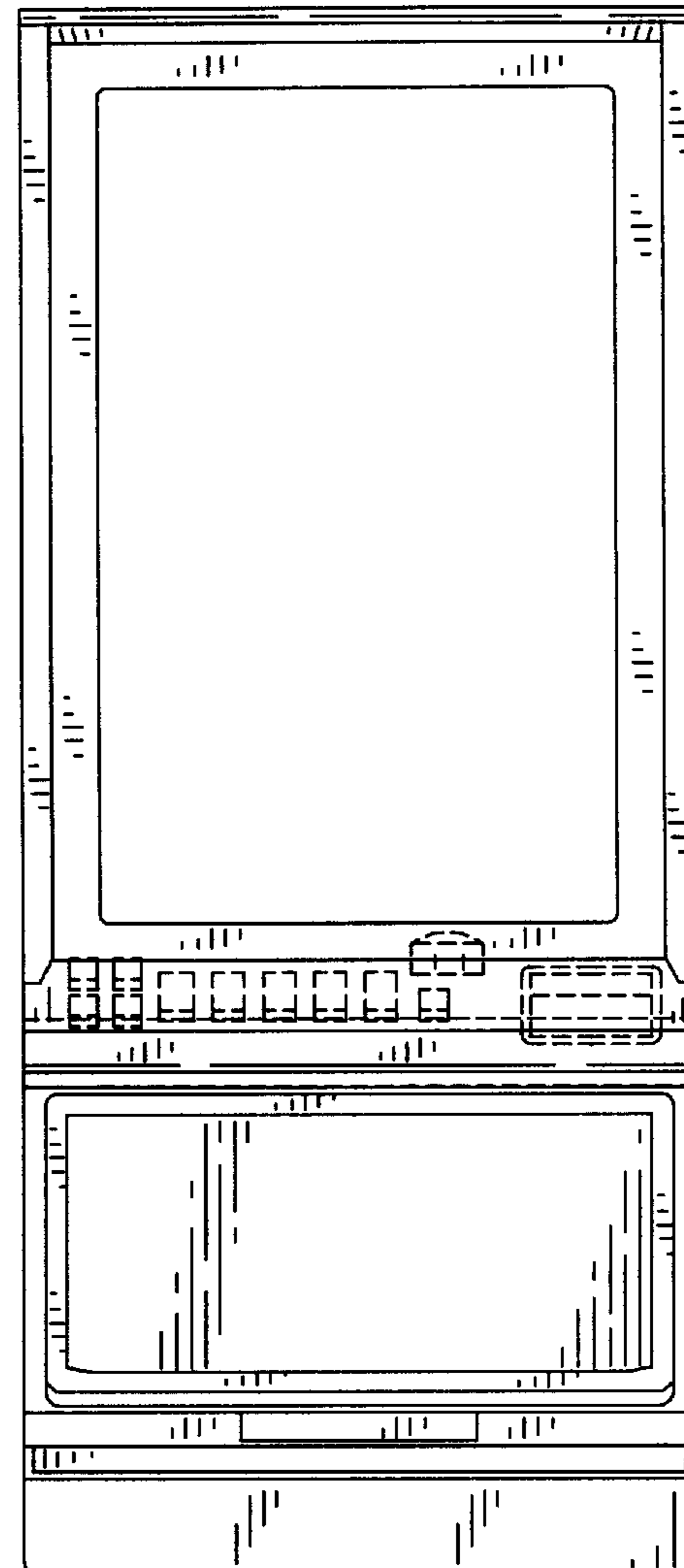

Fig. 9