



US00D525492S

(12) **United States Design Patent**
Peterson

(10) **Patent No.:** **US D525,492 S**
(45) **Date of Patent:** **** Jul. 25, 2006**

(54) **FIBER CEMENT SIDING OVERLAP GAUGE**

(75) Inventor: **Eric L. Peterson**, Maple Lake, MN
(US)
(73) Assignee: **Malco Products, Inc.**, Annandale, MN
(US)
(**) Term: **14 Years**

(21) Appl. No.: **29/208,390**
(22) Filed: **Jun. 28, 2004**

(51) **LOC (8) Cl.** **08-05**
(52) **U.S. Cl.** **D8/14**
(58) **Field of Classification Search** D8/14,
D8/16, 349, 380; 33/646-647
See application file for complete search history.

(56) **References Cited**

U.S. PATENT DOCUMENTS

4,425,714	A	*	1/1984	Kelly, Jr.	33/646
4,654,975	A	*	4/1987	Lopez	33/626
5,400,519	A	*	3/1995	Meyer	33/646
D362,812	S	*	10/1995	Meyer	D10/64
5,522,149	A	*	6/1996	Meyer	33/646
6,367,160	B1	*	4/2002	Rempe	33/647
6,684,521	B1	*	2/2004	Rempe	33/647

OTHER PUBLICATIONS

James Hardie Building Products brochure, "Recognized Tools and Accessories", 2003.
Tim Uhler, "Installing Fiber-Cement Siding", Journal Light Construction, Dec. 2003.
Product Information from the website "indianvalleyinnovation.com", 5 pgs.

* cited by examiner

Primary Examiner—Holly Baynham
(74) *Attorney, Agent, or Firm*—Gerald E. Helget; Briggs and Morgan, P.A.

(57) **CLAIM**

The ornamental design for a fiber cement siding overlap gauge, as shown and described.

DESCRIPTION

FIG. 1 is a perspective view showing my new design for a fiber cement siding overlap gauge;
FIG. 2 is a leftside elevational view which is a mirror image of the right side elevational view;
FIG. 3 is a bottom plan view;
FIG. 4 is a top plan view;
FIG. 5 is a rear elevational view; and,
FIG. 6 is a front elevational view.

1 Claim, 2 Drawing Sheets

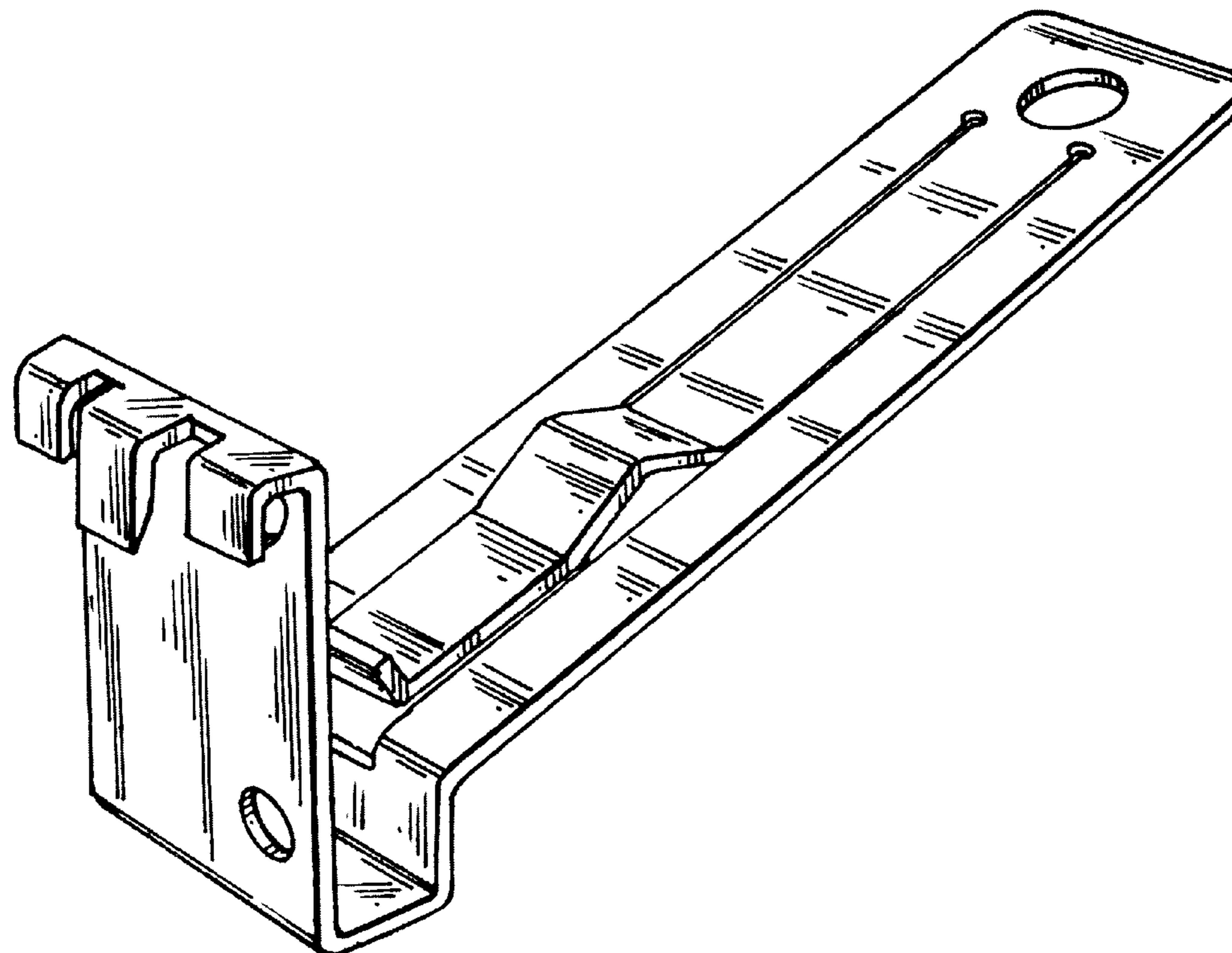

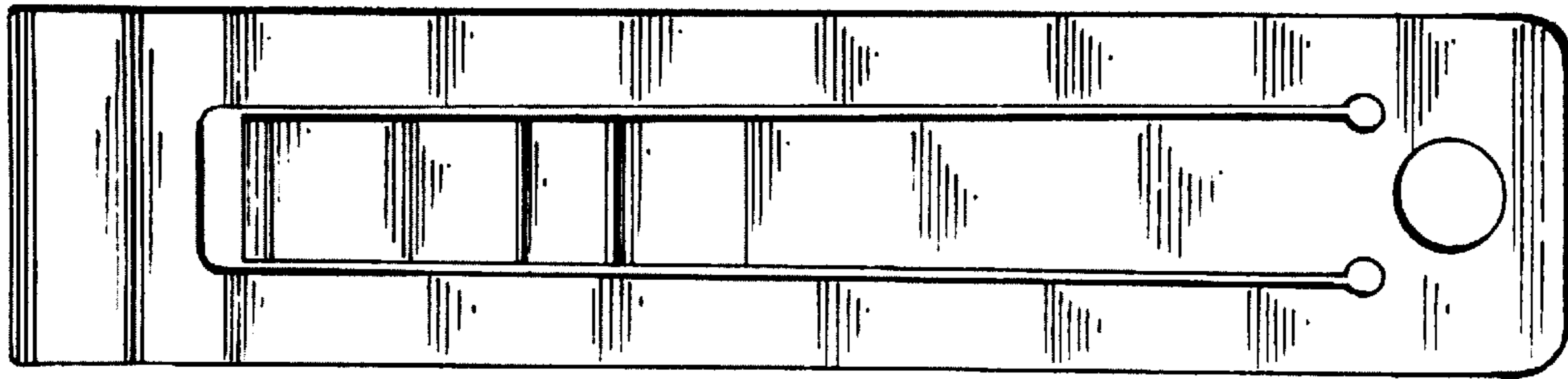

Fig. 3.

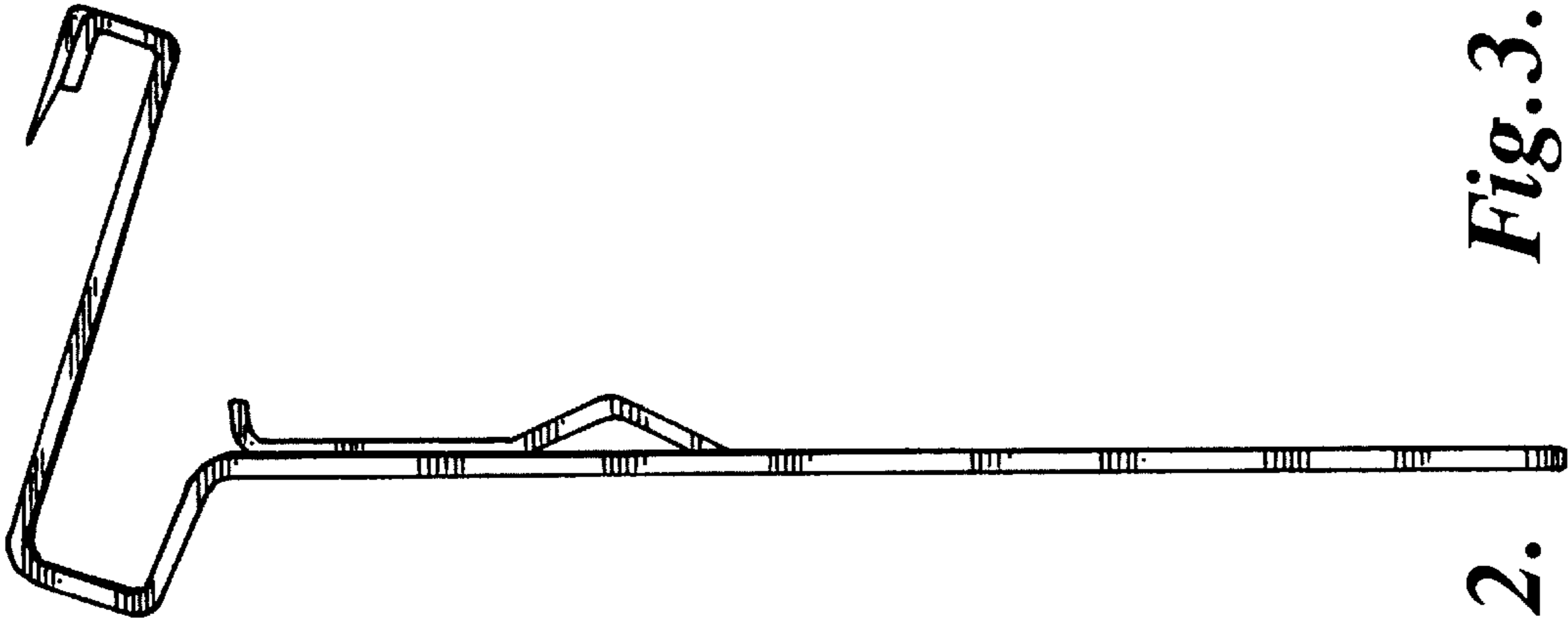

Fig. 2.

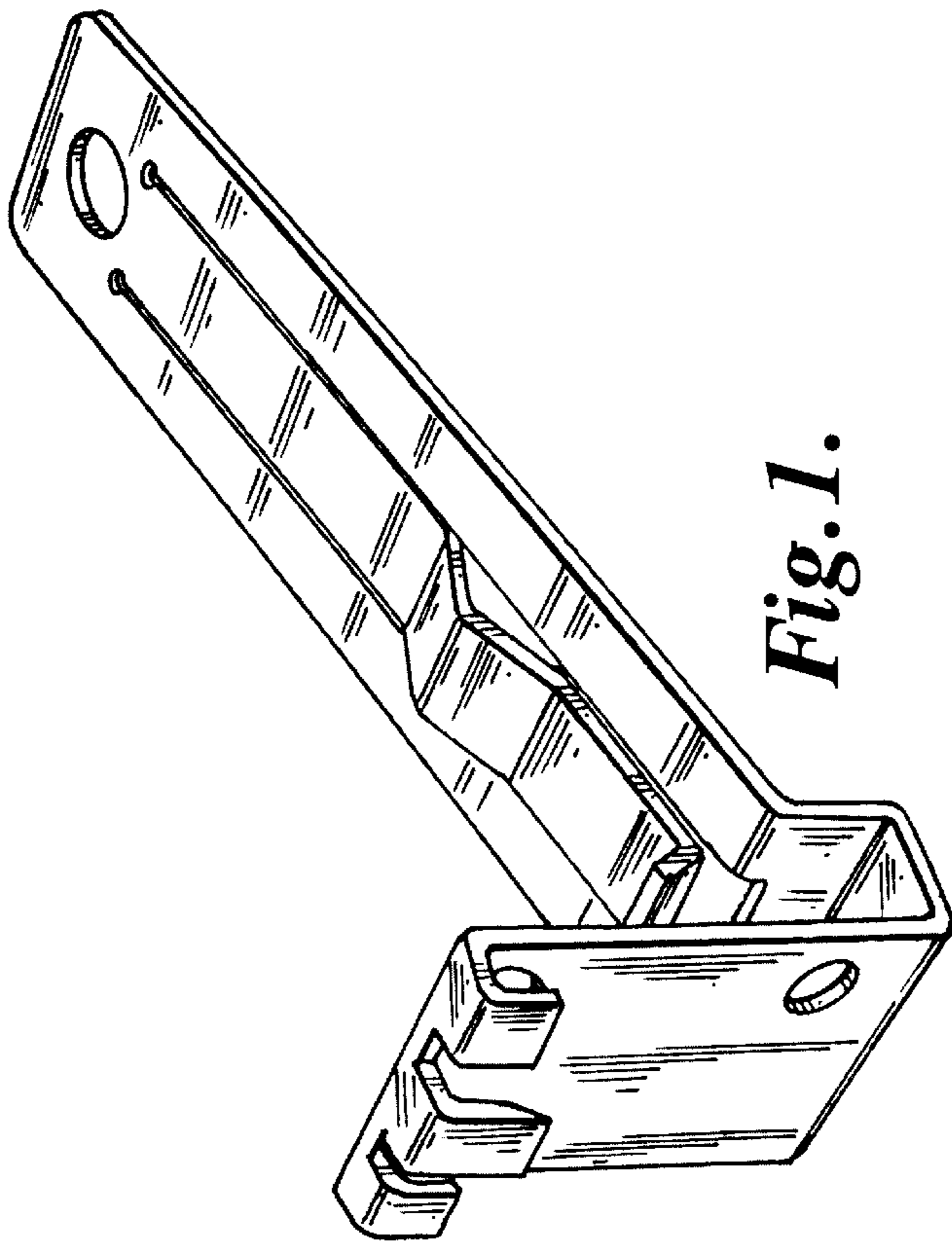

Fig. 1.

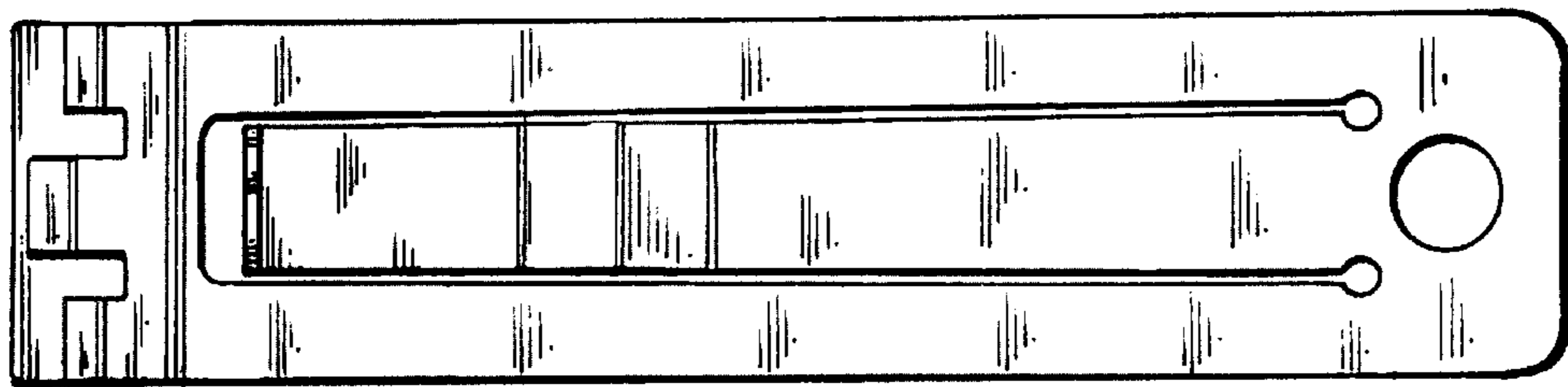

Fig. 4.

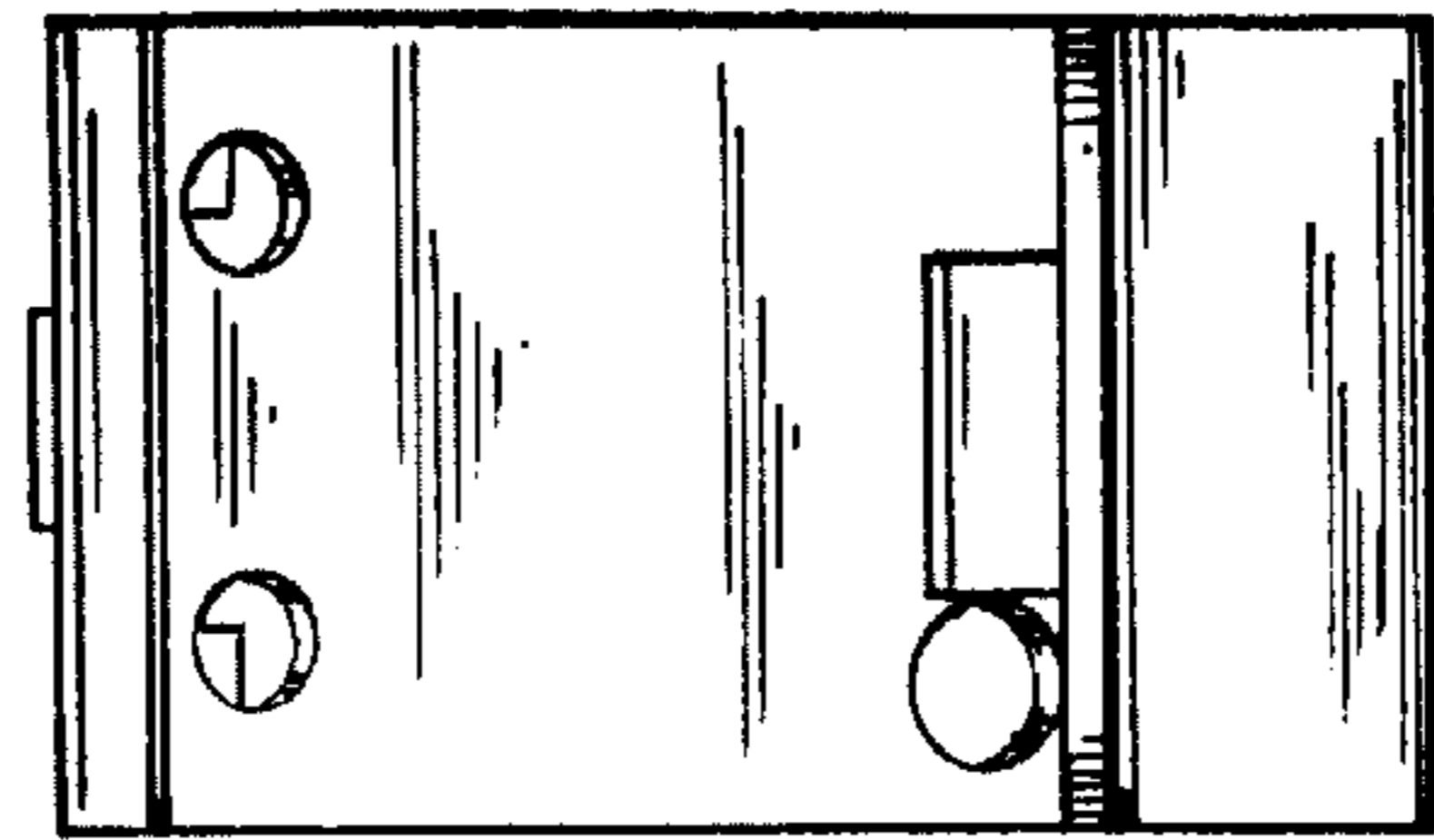

Fig. 5.

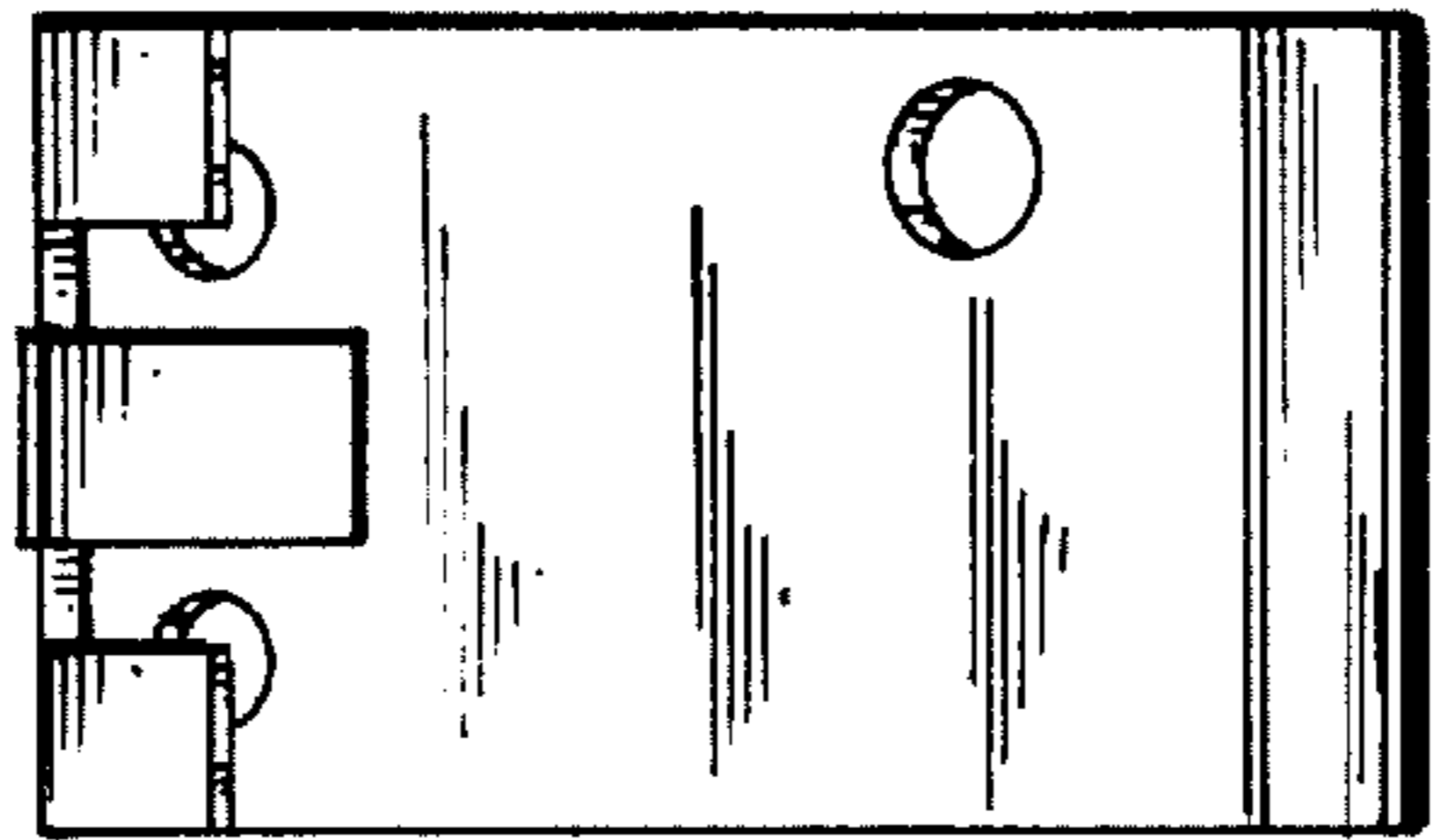

Fig. 6.