

US00D524718S

(12) **United States Design Patent**
Scott et al.

(10) **Patent No.:** **US D524,718 S**

(45) **Date of Patent:** **** Jul. 11, 2006**

(54) **RIGID COAXIAL ROTOR HELICOPTER
WITH DUAL AUXILIARY PROPULSION**

D363,054 S * 10/1995 Taylor et al. D12/327
D375,077 S * 10/1996 Taylor et al. D12/327
D388,048 S * 12/1997 Taylor et al. D12/328
D425,853 S * 5/2000 Caporaletti D12/327

(75) Inventors: **Mark W. Scott**, Bethany, CT (US);
William J. Eadie, Cheshire, CT (US)

* cited by examiner

(73) Assignee: **Sikorsky Aircraft Corporation**,
Stratford, CT (US)

Primary Examiner—Marcus A. Jackson

(**) Term: **14 Years**

(57) **CLAIM**

(21) Appl. No.: **29/231,086**

The ornamental design for a rigid coaxial rotor helicopter with dual auxiliary propulsion, as shown and described.

(22) Filed: **May 31, 2005**

DESCRIPTION

(51) **LOC (8) Cl.** **12-07**

(52) **U.S. Cl.** **D12/327**

(58) **Field of Classification Search** D12/327-329;
244/17.11, 17.19, 17.21

See application file for complete search history.

FIG. 1 is a perspective view of the rigid coaxial rotor helicopter with dual auxiliary propulsion;
FIG. 2 is another perspective view thereof;
FIG. 3 is a left side elevational view thereof;
FIG. 4 is a right side elevational view thereof;
FIG. 5 is a top plan view thereof;
FIG. 6 is a bottom plan view thereof;
FIG. 7 is a front elevational view thereof; and,
FIG. 8 is a rear elevational view thereof.

(56) **References Cited**

U.S. PATENT DOCUMENTS

D357,894 S * 5/1995 Arnold et al. D12/327
D361,053 S * 8/1995 Whyte et al. D12/327

1 Claim, 5 Drawing Sheets

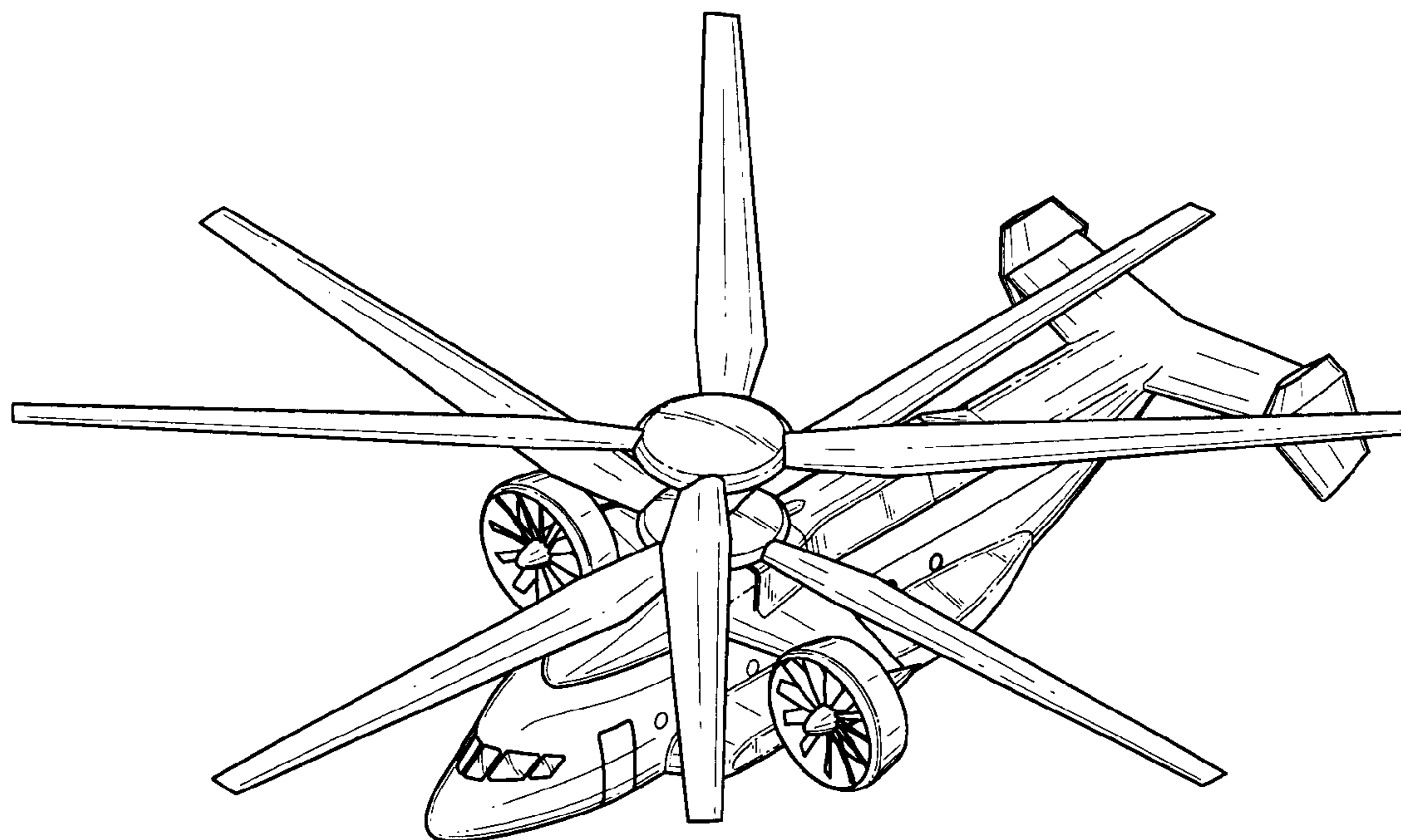

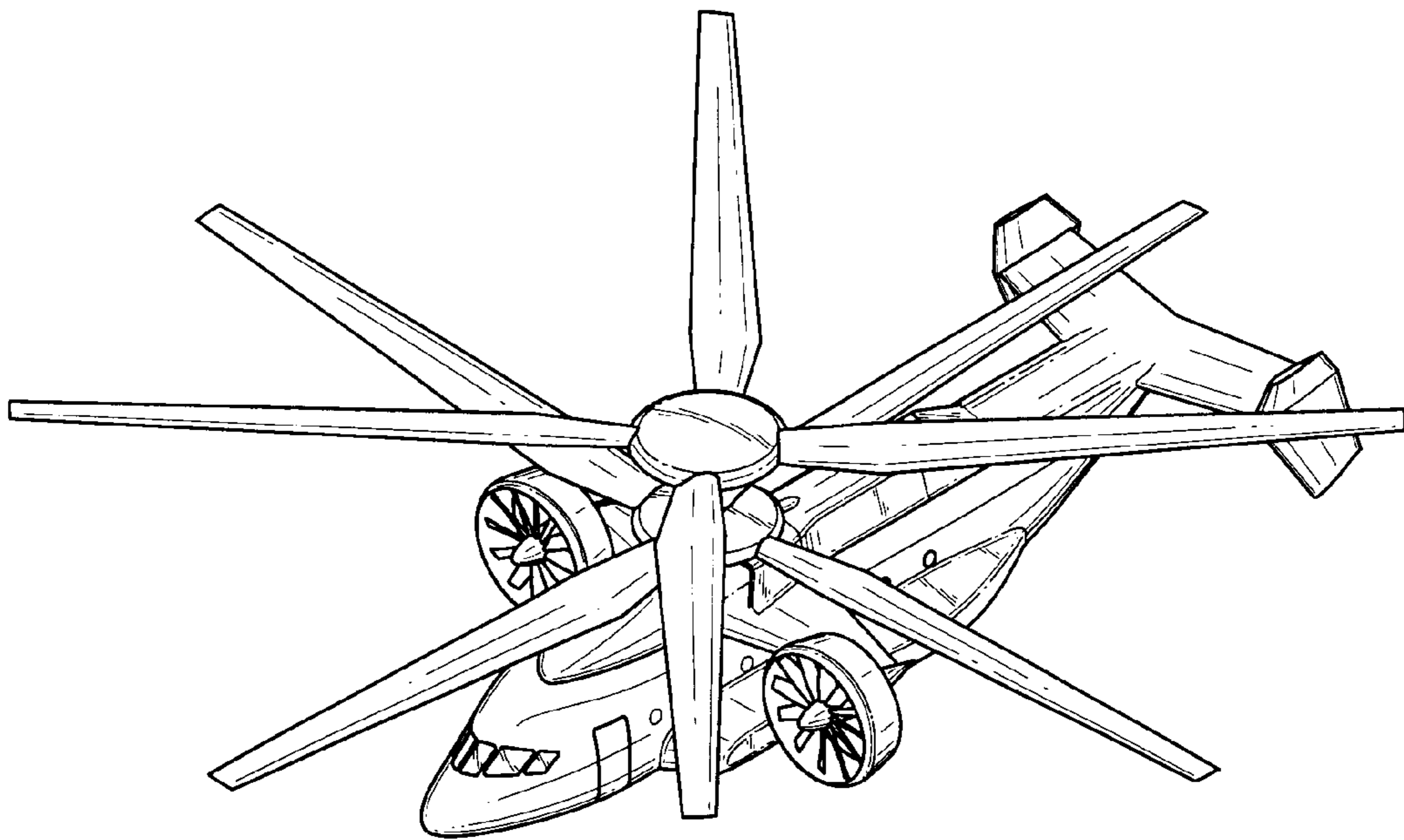

FIG. 1

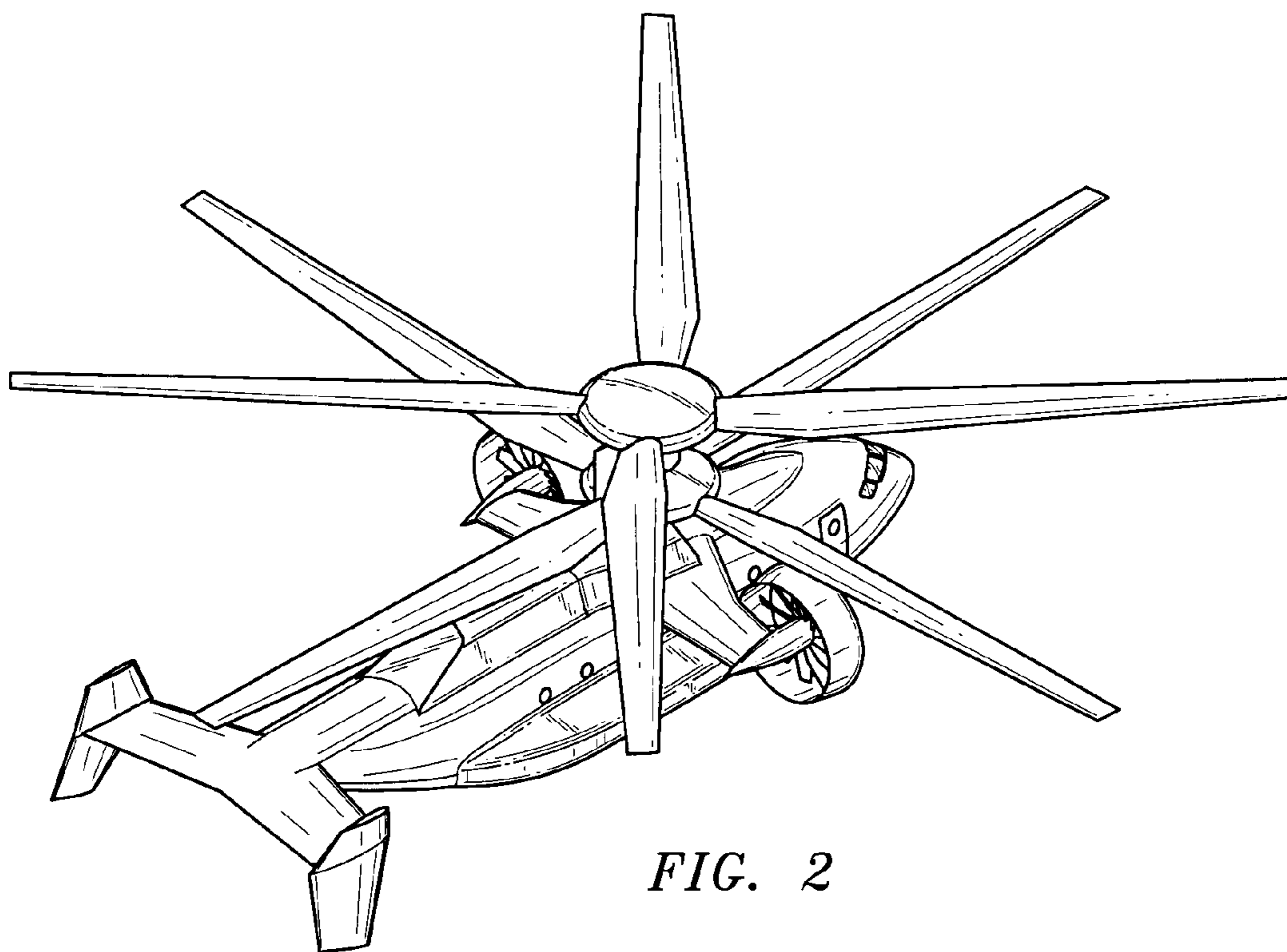

FIG. 2

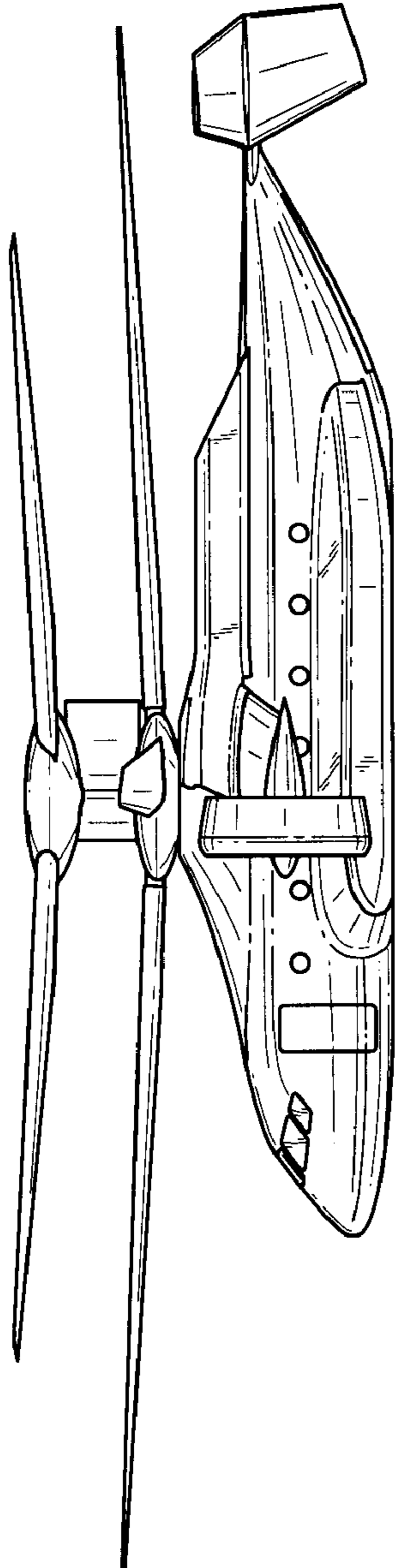

FIG. 3

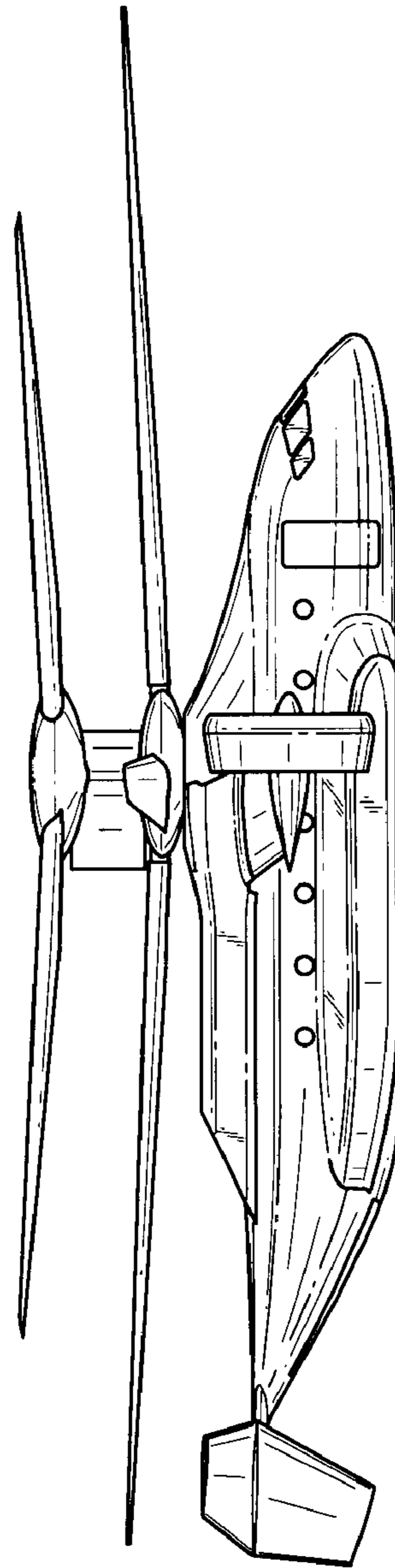

FIG. 4

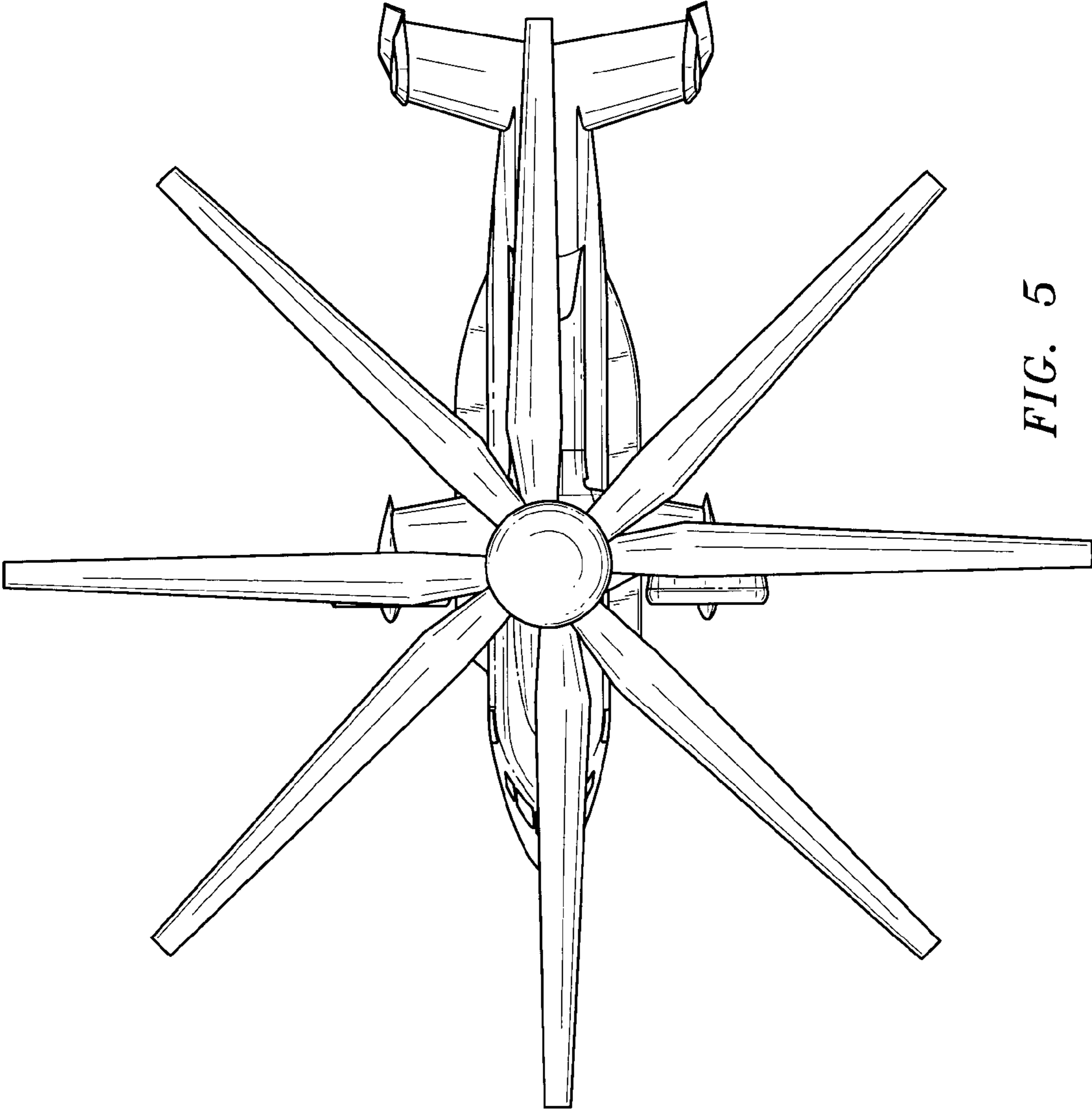

FIG. 5

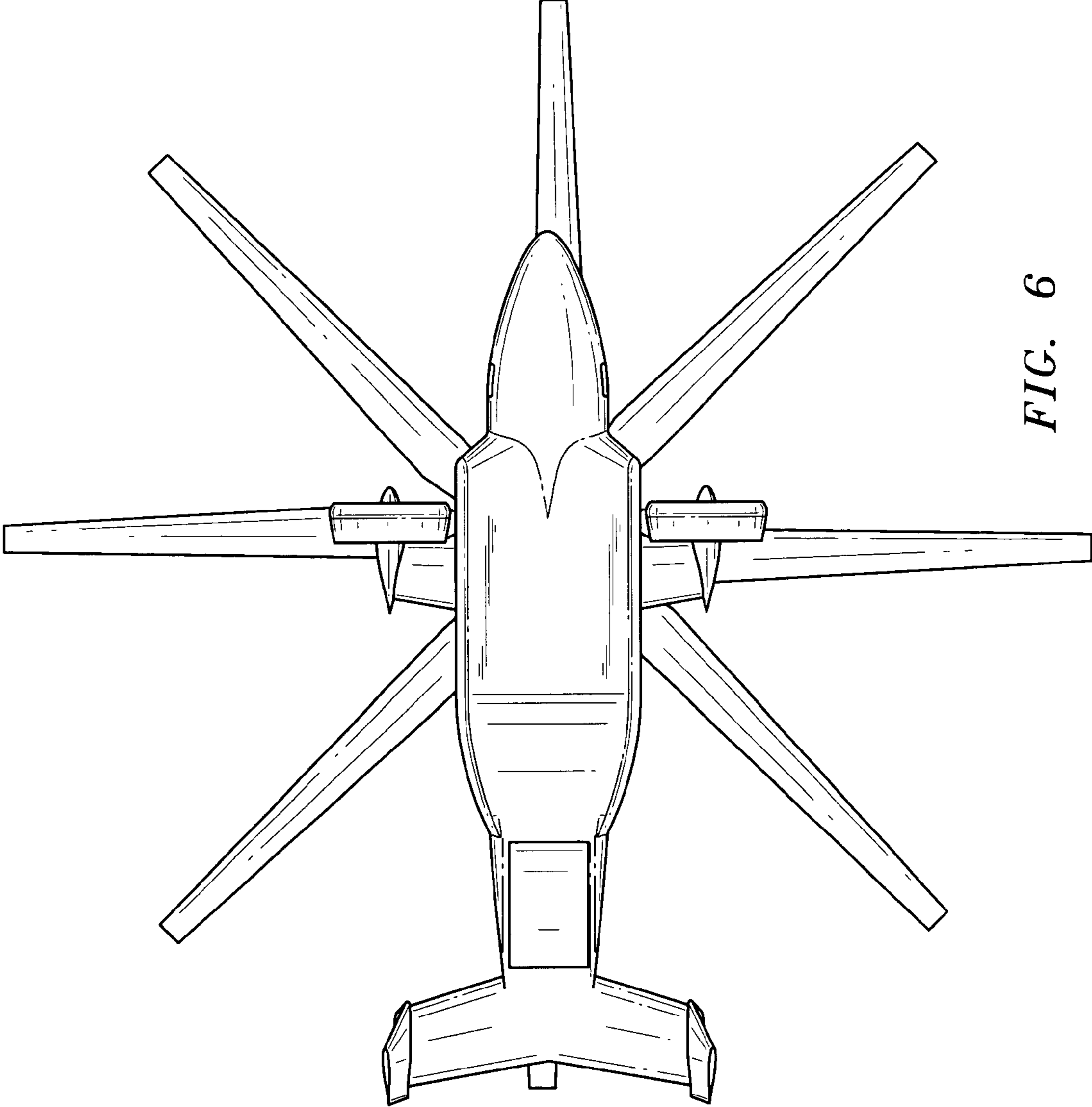

FIG. 6

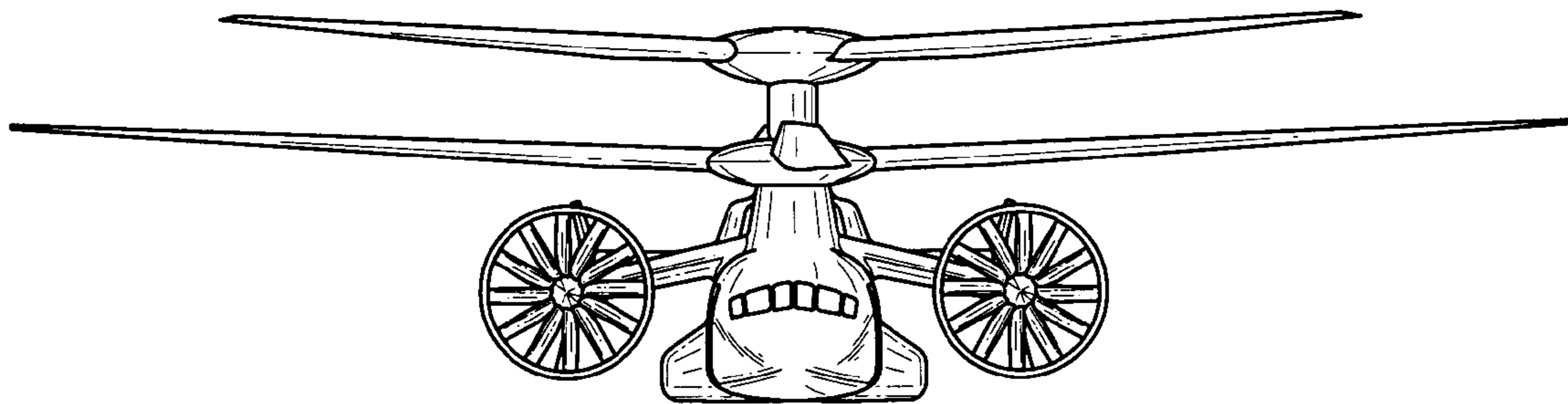

FIG. 7

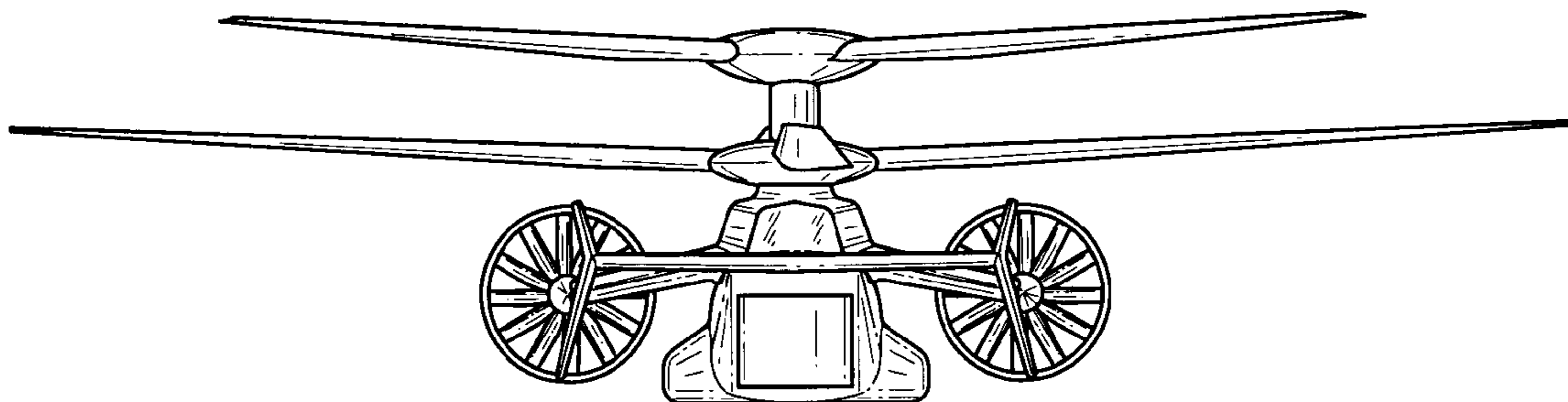

FIG. 8