



US00D524299S

(12) **United States Design Patent**  
**Ishikawa et al.**

(10) **Patent No.:** **US D524,299 S**  
(45) **Date of Patent:** **\*\* Jul. 4, 2006**

(54) **SPEAKER FOR AN AUTOMOBILE**

D497,902 S \* 11/2004 Farinelli et al. .... D14/216

(75) Inventors: **Keiji Ishikawa**, Matsusaka (JP);  
**Hiromi Sawa**, Matsusaka (JP)

FOREIGN PATENT DOCUMENTS

JP 1157504 11/2002  
JP 1157507 11/2002

(73) Assignee: **Matsushita Electric Industrial Co., Ltd.**, Osaka (JP)

OTHER PUBLICATIONS

(\*\*) Term: **14 Years**

Myer Emco catalog, p. 29, MB Quart 'RKB' series, bridge mounted component speakers.\*

(21) Appl. No.: **29/225,322**

\* cited by examiner

(22) Filed: **Mar. 15, 2005**

*Primary Examiner*—Nanda Bondade

(30) **Foreign Application Priority Data**

(74) *Attorney, Agent, or Firm*—Brinks Hofer, Gilson & Lione

Sep. 16, 2004 (JP) ..... 2004-028136

(57) **CLAIM**

(51) **LOC (8) Cl.** ..... **14-01**

We claim the ornamental design for a speaker for an automobile, as shown and described.

(52) **U.S. Cl.** ..... **D14/221**

(58) **Field of Classification Search** ..... D14/204,  
D14/207, 209–217, 221–222, 157, 172, 356,  
D14/496; 181/143–144, 147–148, 150, 157,  
181/198–199, 153; 381/300–302, 306, 333,  
381/345, 361–364, 332, 336, 380, 186, 87  
See application file for complete search history.

**DESCRIPTION**

FIG. 1 is a top perspective view of a speaker for an automobile of the present invention;  
FIG. 2 is a top view thereof;  
FIG. 3 is a first side view thereof;  
FIG. 4 is a second side view thereof;  
FIG. 5 is a third side view thereof;  
FIG. 6 is a fourth side view thereof;  
FIG. 7 is a bottom view thereof; and,  
FIG. 8 is a bottom perspective view thereof.

(56) **References Cited**

U.S. PATENT DOCUMENTS

4,672,675 A \* 6/1987 Powell et al. .... 381/87  
D402,989 S \* 12/1998 Church et al. .... D14/216  
D488,802 S \* 4/2004 Uehara et al. .... D14/216  
D489,359 S \* 5/2004 Hakoda ..... D14/215

**1 Claim, 4 Drawing Sheets**

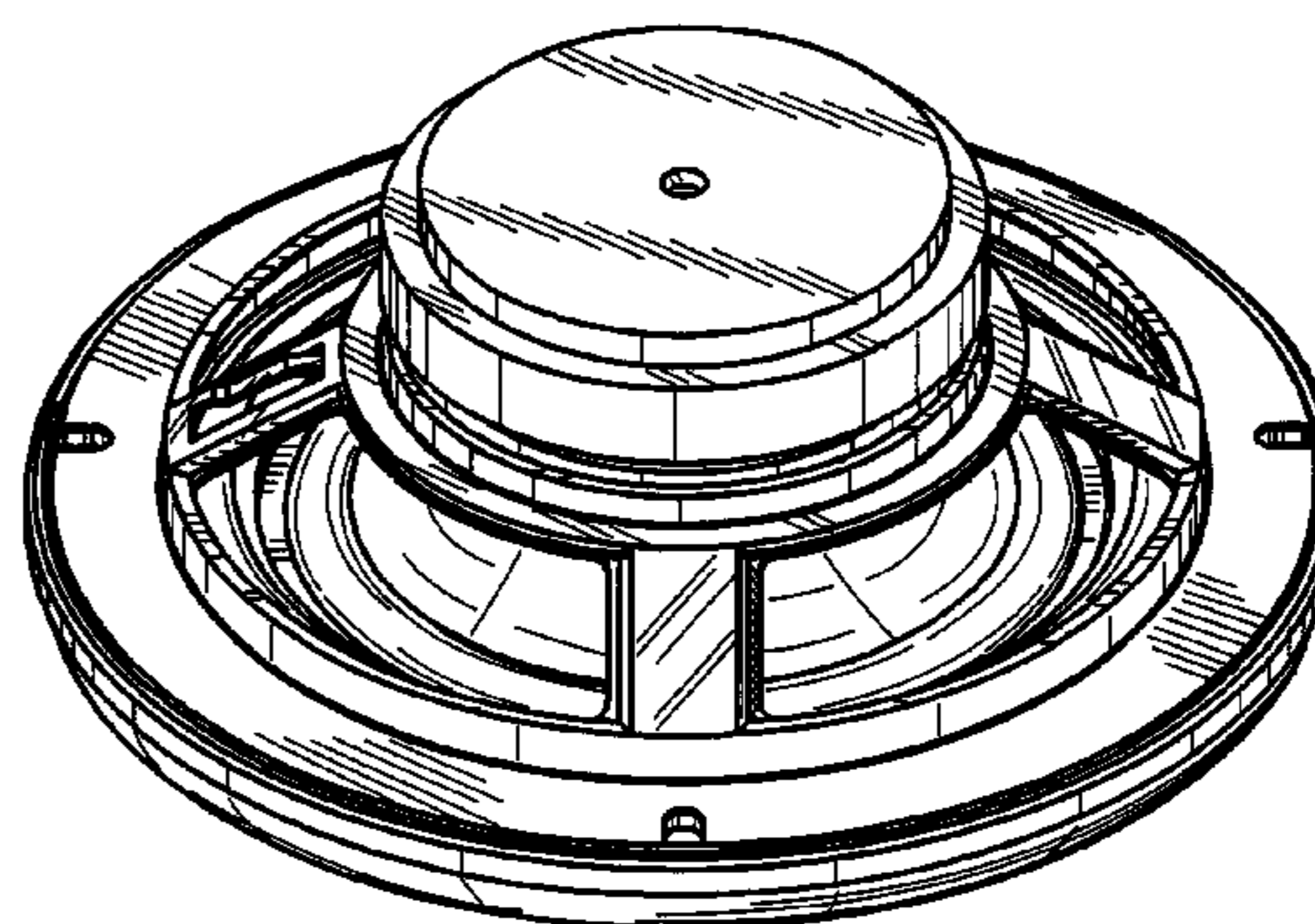
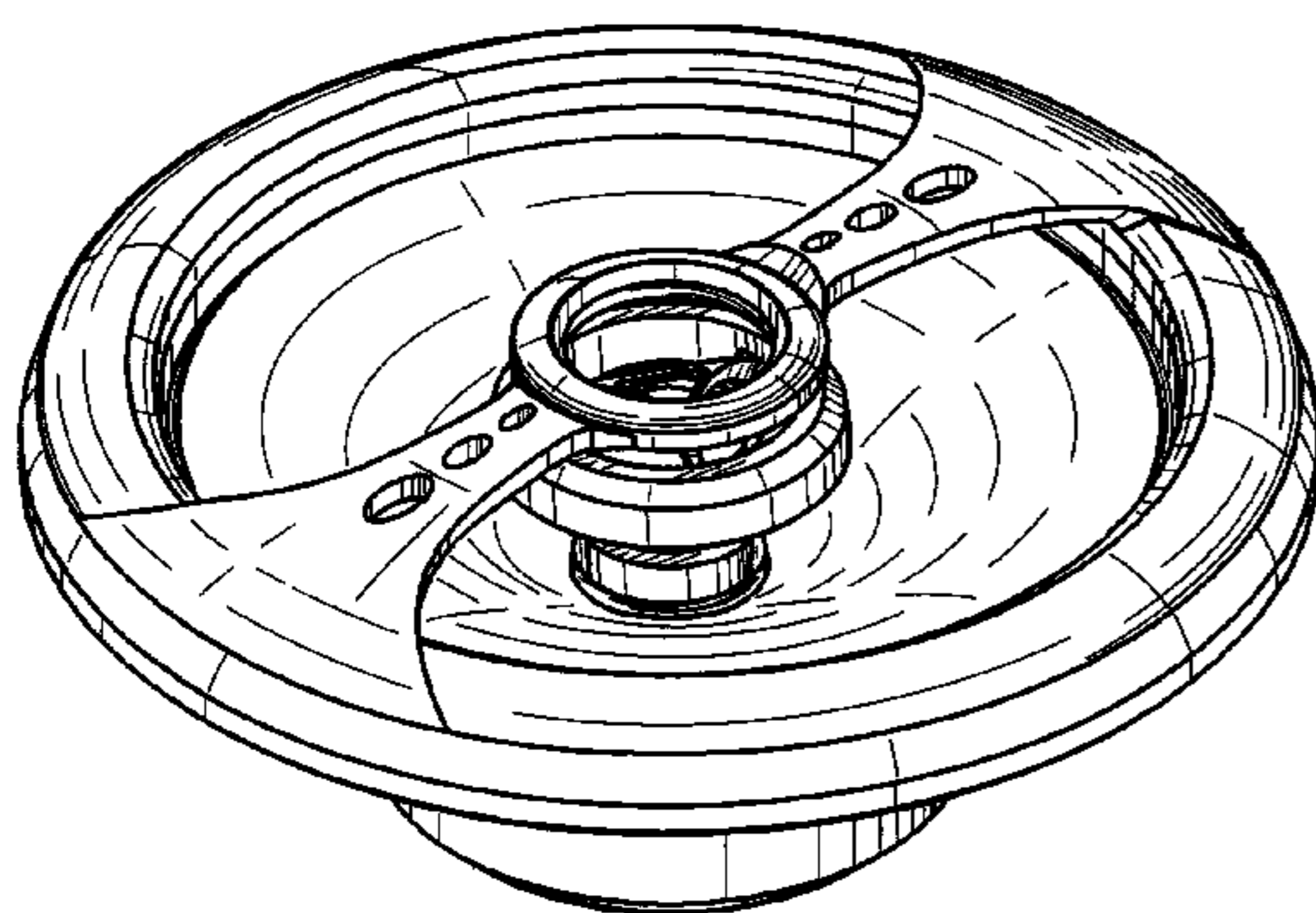

FIG.1

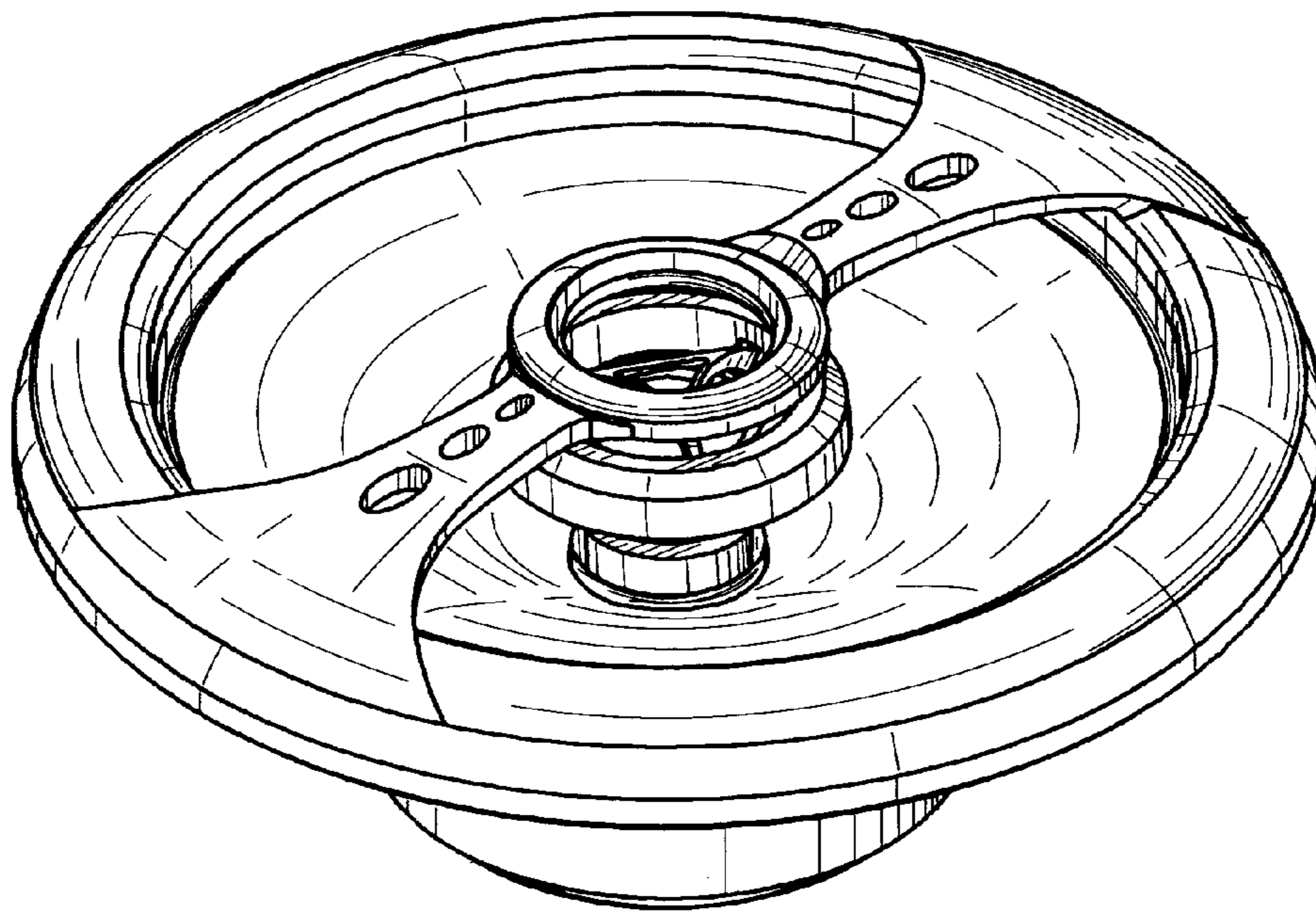

FIG.2

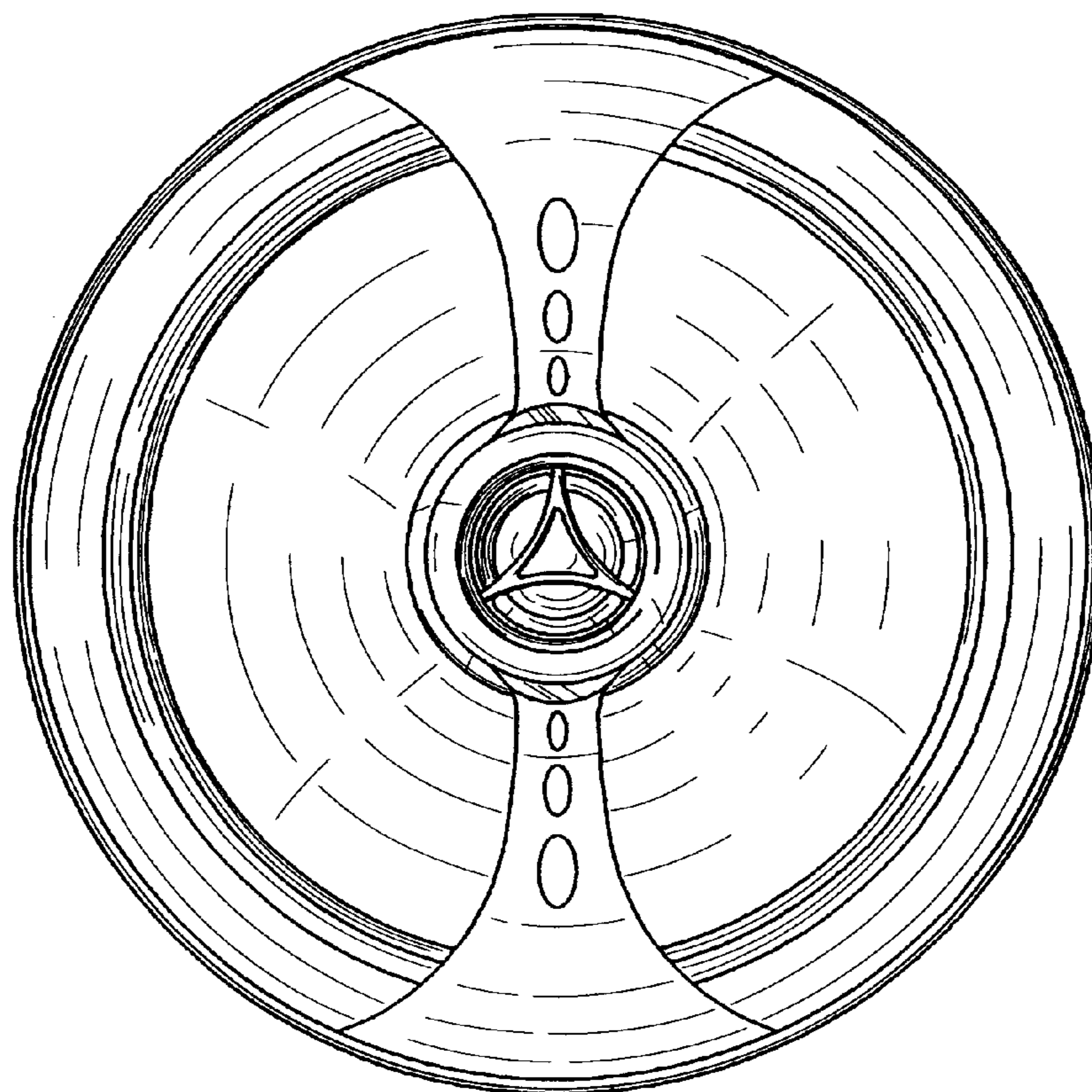

FIG.3



FIG.4

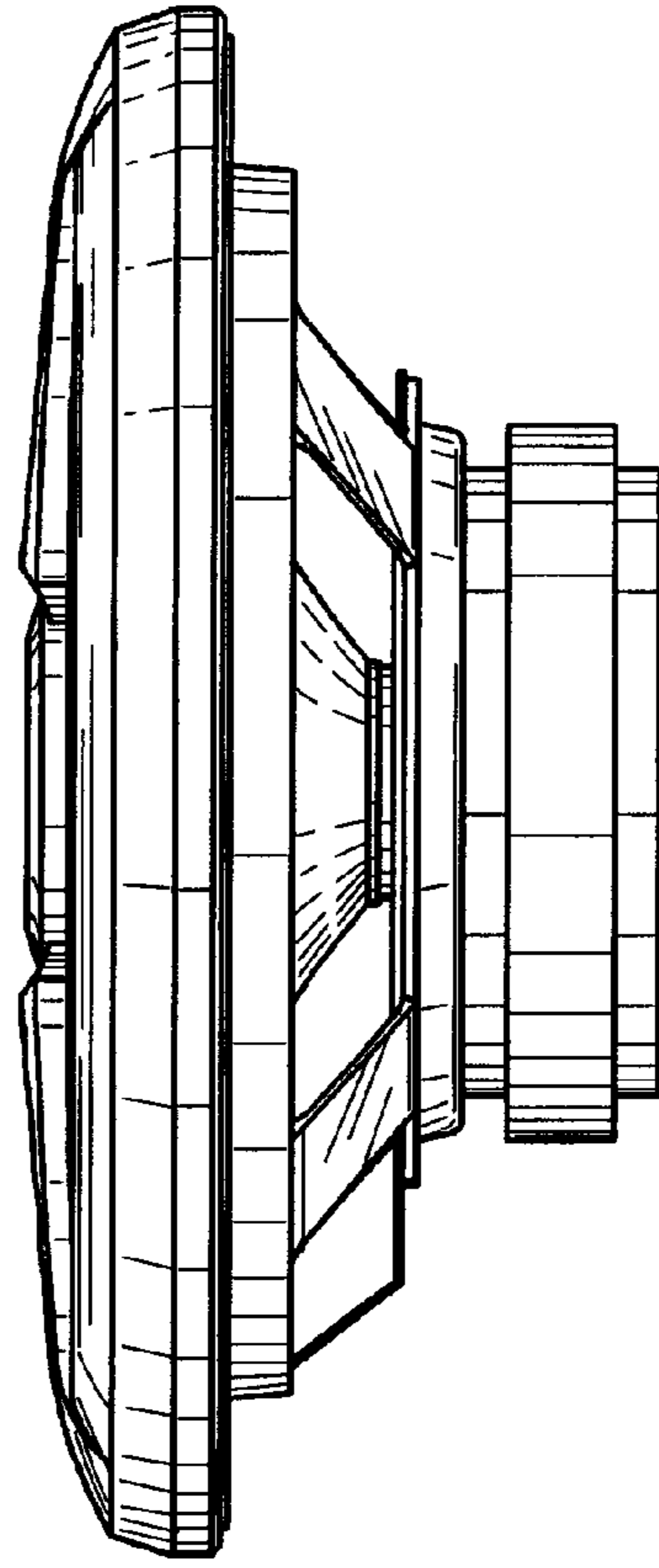

FIG.5

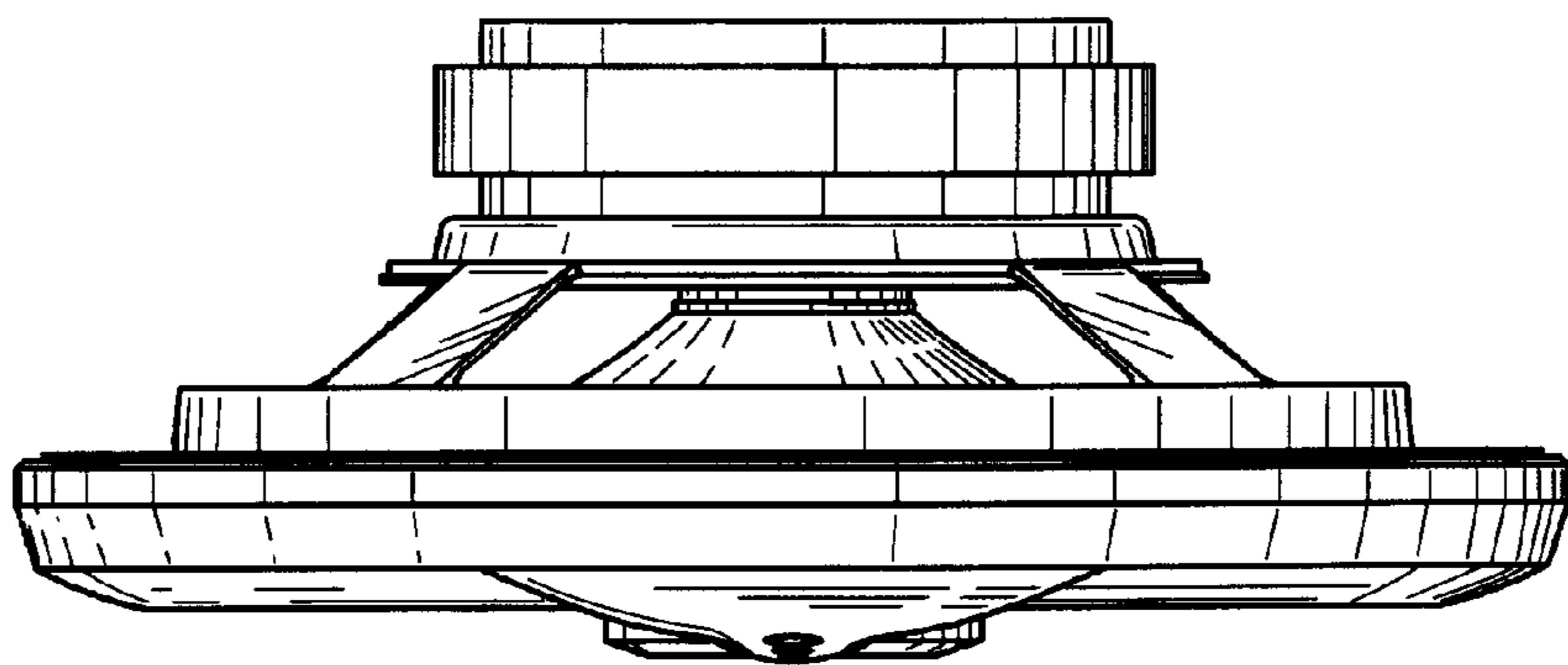

FIG.6

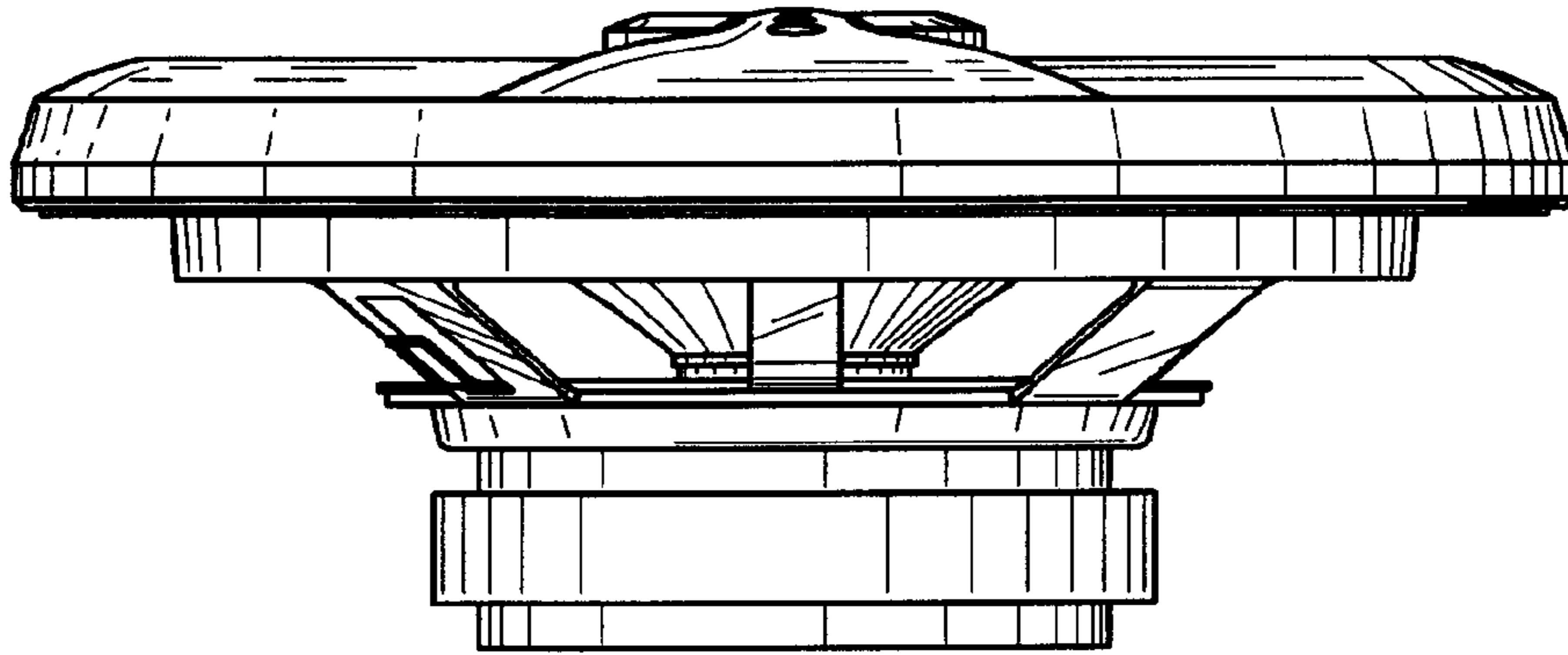

FIG.7

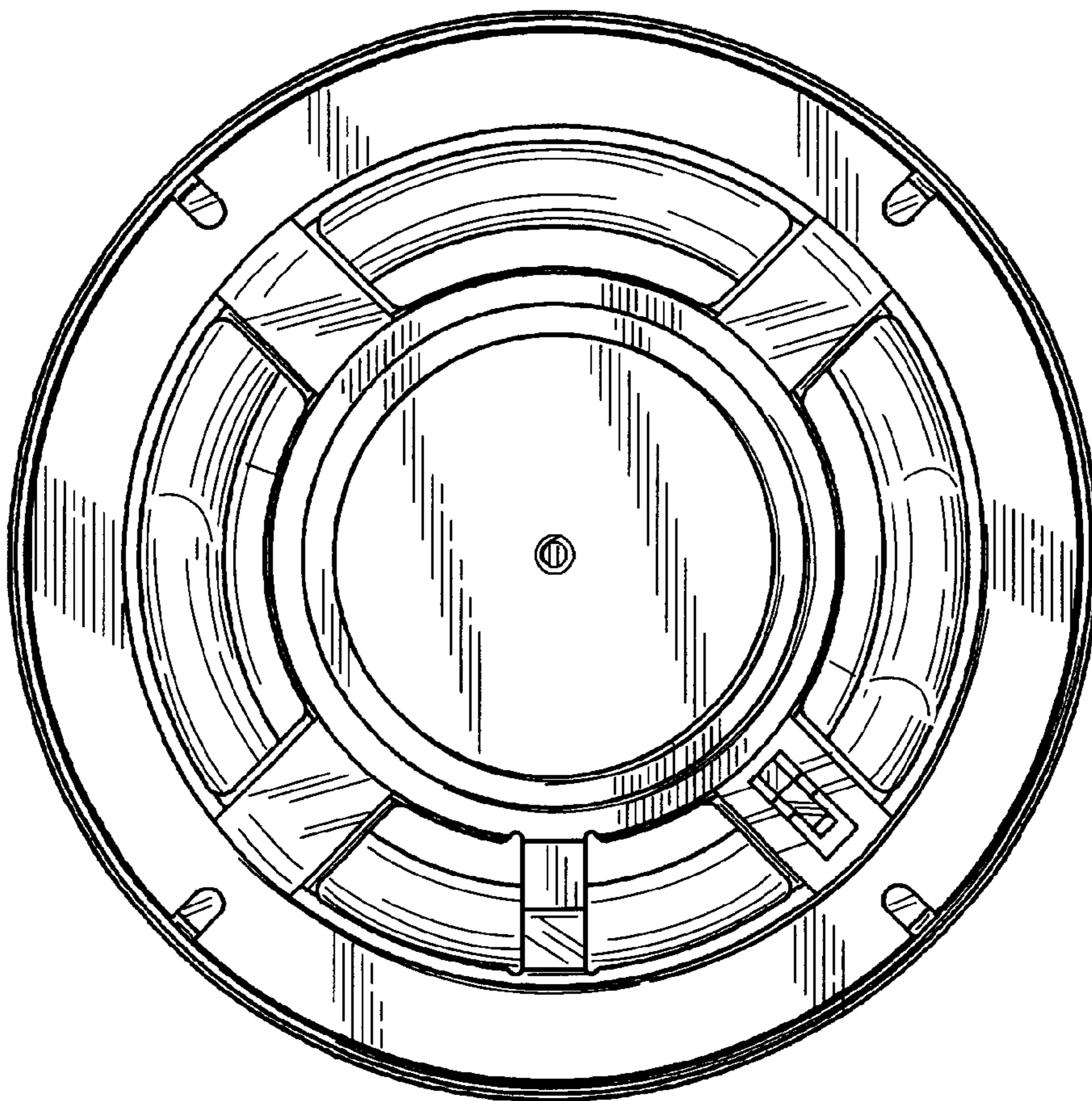

FIG.8

