



US00D524190S

(12) **United States Design Patent**
Fisker et al.

(10) **Patent No.:** **US D524,190 S**
(45) **Date of Patent:** **** Jul. 4, 2006**

(54) **AUTOMOTIVE EXTERIOR**

(75) Inventors: **Henrik Fisker**, Newport Beach, CA (US); **John Paxton**, Long Beach, CA (US); **David Woodhouse**, Newport Coast, CA (US)

(73) Assignee: **Ford Global Technologies, LLC**, Dearborn, MI (US)

(**) Term: **14 Years**

(21) Appl. No.: **29/220,785**

(22) Filed: **Jan. 6, 2005**

(51) **LOC (8) Cl.** **12-08**

(52) **U.S. Cl.** **D12/91**

(58) **Field of Classification Search** D12/90–92,
D12/86; D21/548, 549; 296/181.1, 181.5
See application file for complete search history.

(56) **References Cited**

U.S. PATENT DOCUMENTS

D458,189 S	*	6/2002	Wyatt	D12/91
D470,796 S	*	2/2003	Nakajima et al.	D12/91
D499,988 S	*	12/2004	Minami et al.	D12/91
D505,095 S	*	5/2005	Frye	D12/91

OTHER PUBLICATIONS

www.landroverusa.com/us/en/Vehicles/Range_Rover/Overview, Land Rover US—Overview, 3 pages.
www.landroverusa.com/us/en/_misc/EnlargeImagePopup, Land Rover US—EnlargeImagePopup, 1 page.
www.landroverusa.com/us/en/Vehicles/Range_Rover/Photo, Land Rover US—Photos, 20 pages.

Advertisement: Autoweb Re: 2005 GMC Safari (pp. 1–8).
Advertisement: Autoweb Re: 2005 Chrysler Town & Country (pp. 1–8).

Advertisement: Autoweb Re: 2005 Honda Odyssey EX 5–Spd AT (pp. 1–6).

Advertisement: Autoweb Re: 2005 Toyota Sienna CE with 7 Passenger Seating (pp. 1–6).

* cited by examiner

Primary Examiner—Melody N. Brown

(74) *Attorney, Agent, or Firm*—Frank A. MacKenzie

(57) **CLAIM**

The ornamental design for an automotive exterior, as shown and described.

DESCRIPTION

FIG. 1 is a right side/front end perspective view of an automotive exterior in accordance with the present invention, wherein a left side/front end perspective view is a mirror image thereof;

FIG. 2 is a left side perspective view of the automotive exterior of FIG. 1, wherein a right side perspective view is a mirror image thereof; and,

FIG. 3 is a left side/rear end perspective view of the automotive exterior of FIG. 1, wherein the right side/rear end perspective view is a mirror image thereof.

The broken lines are for illustrative purposes only and form no part of the claimed design.

The top plan view is plain and unornamented and is not being claimed as part of the design being claimed.

1 Claim, 3 Drawing Sheets

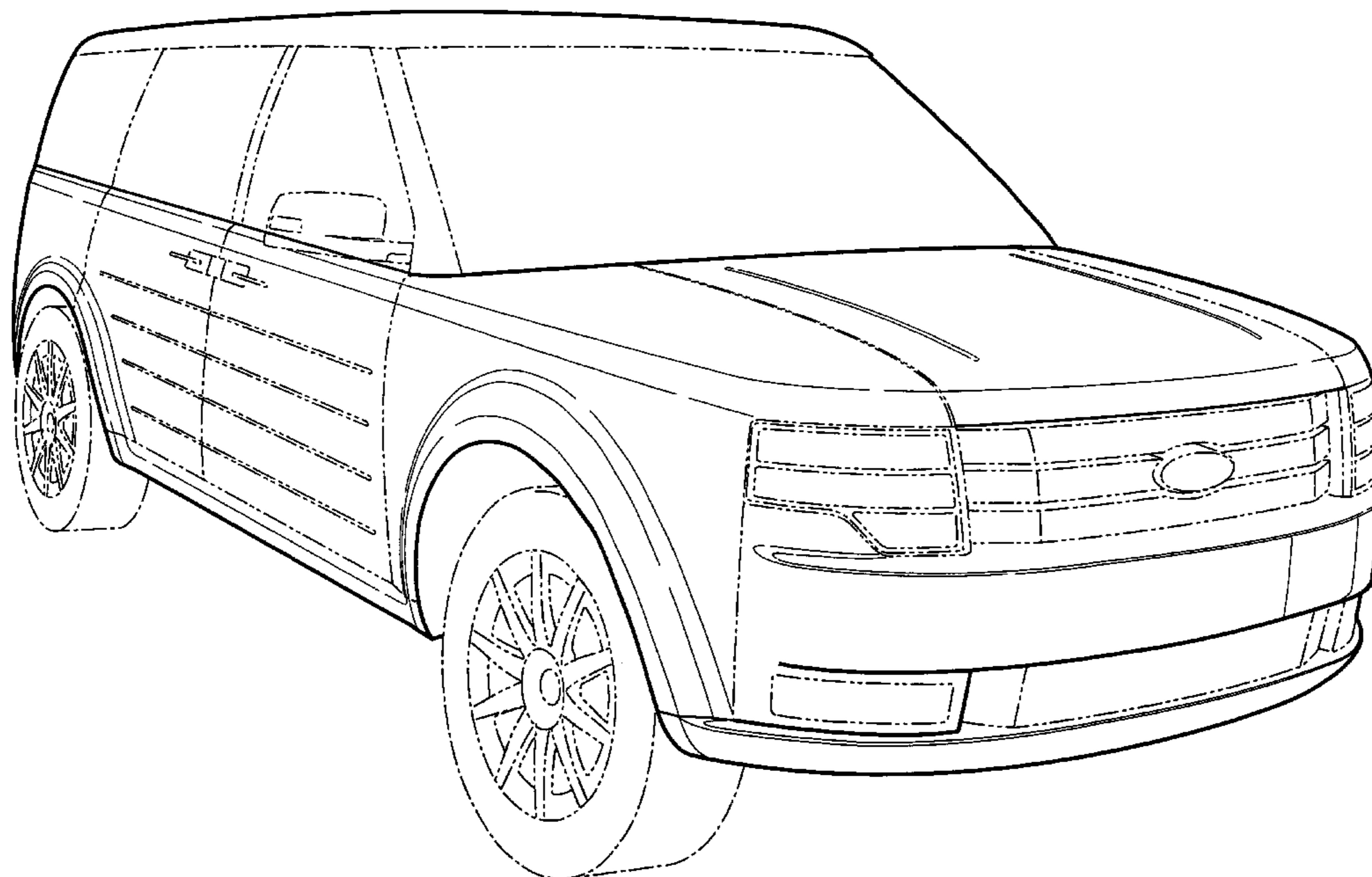

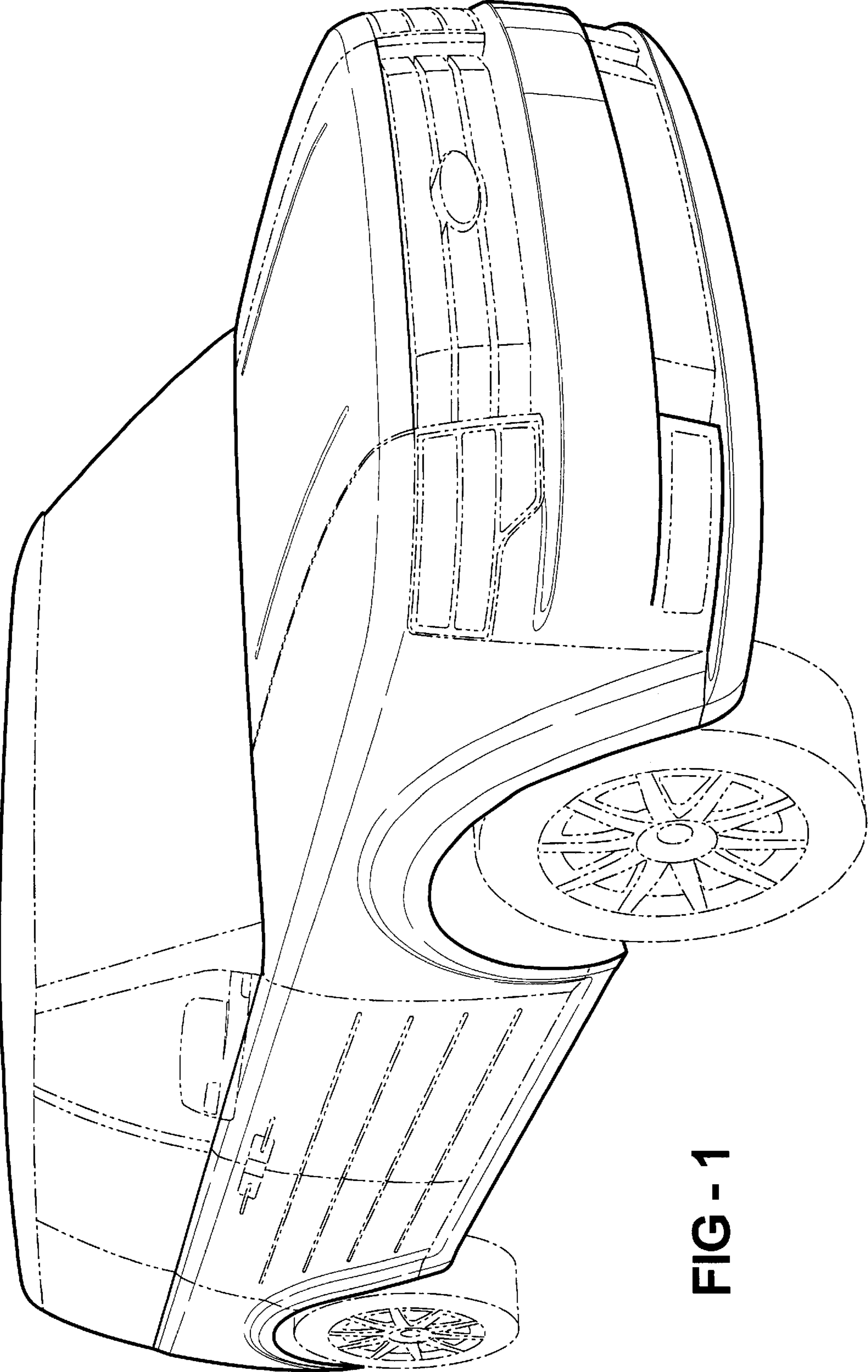

FIG - 1

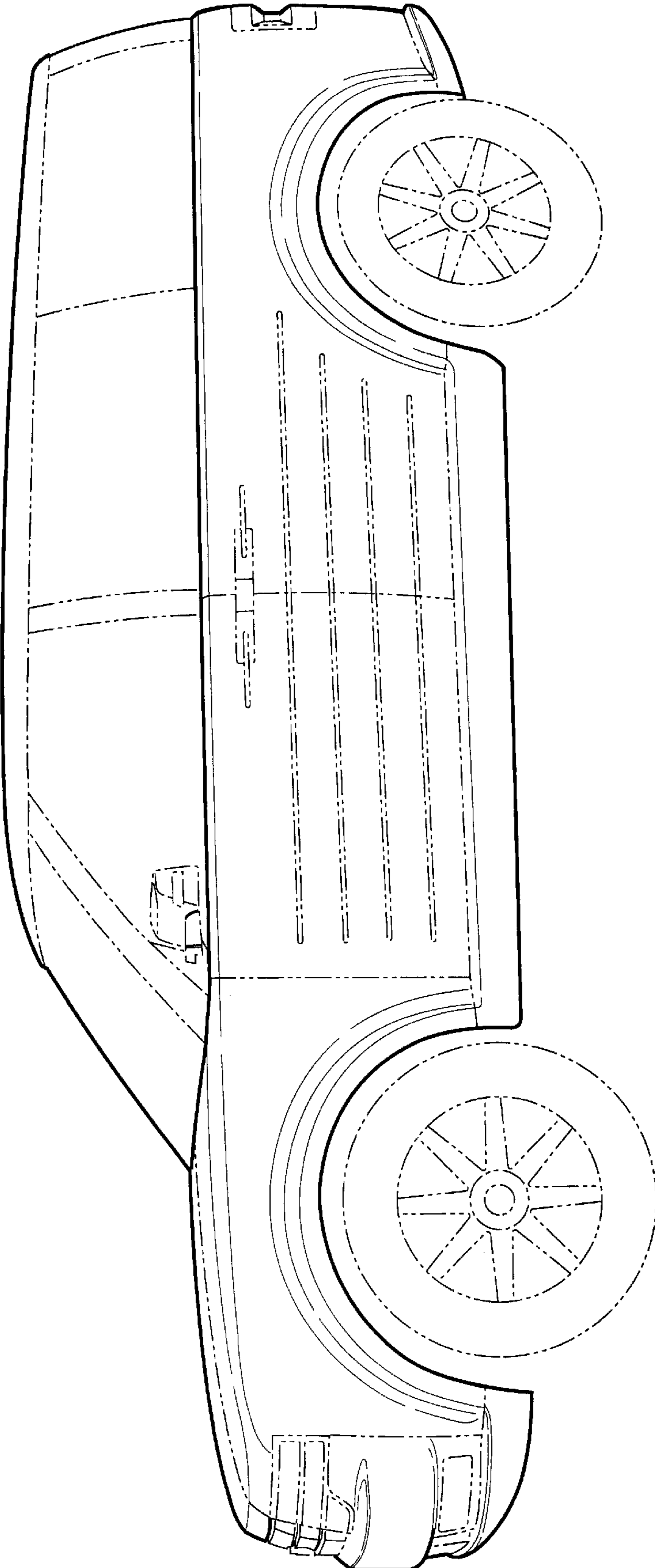

FIG - 2

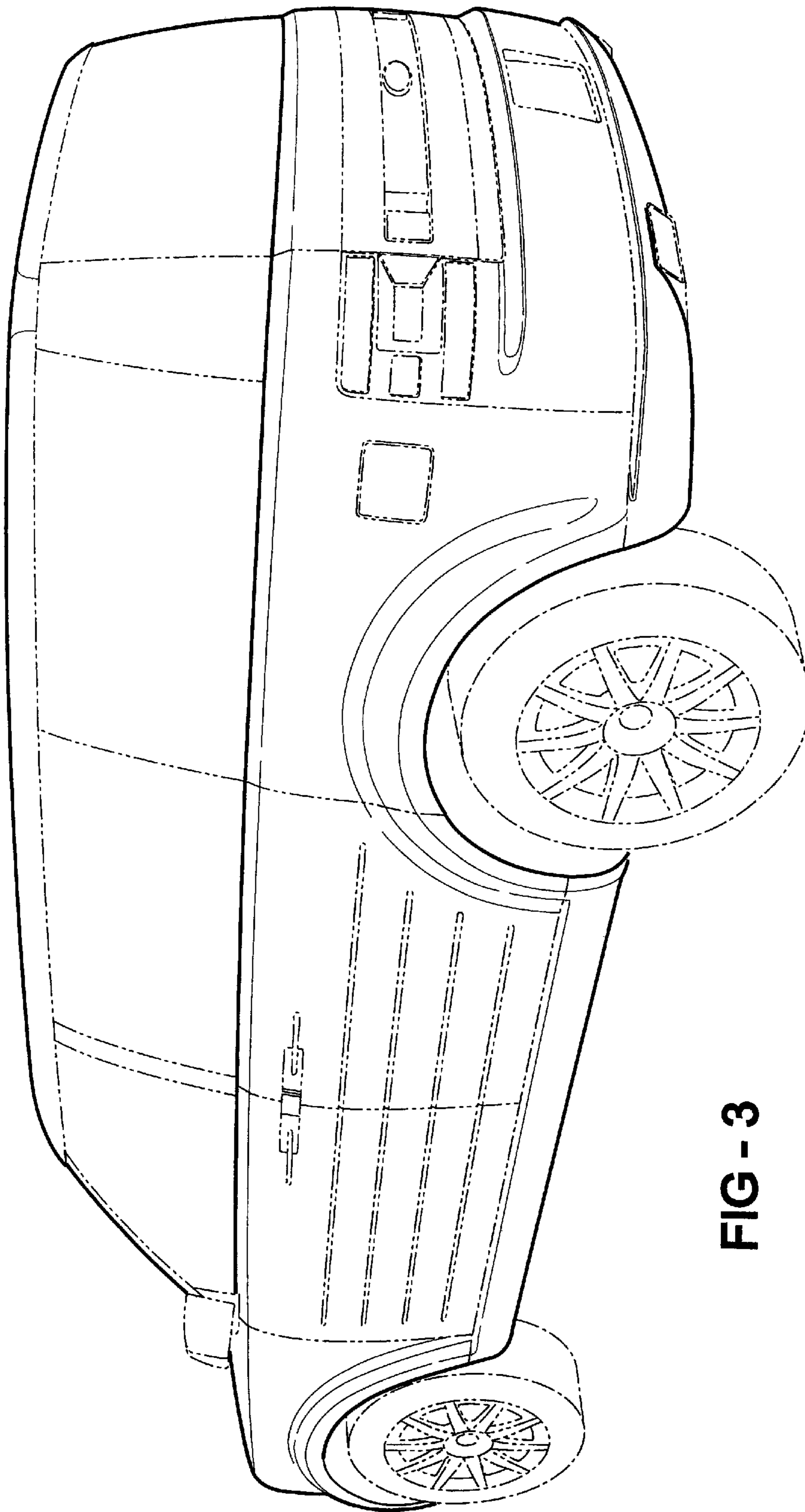

FIG - 3