



US00D524006S

(12) **United States Design Patent**
Verb

(10) **Patent No.:** **US D524,006 S**

(45) **Date of Patent:** **** Jun. 27, 2006**

(54) **KNEE CART**

(76) **Inventor:** **Patti A. Verb**, 7707 W. Sand Beach Rd., Oak Harbor, OH (US) 43449

(**) **Term:** **14 Years**

(21) **Appl. No.:** **29/205,972**

(22) **Filed:** **May 24, 2004**

(51) **LOC (8) Cl.** **12-02**

(52) **U.S. Cl.** **D34/17**

(58) **Field of Classification Search** D34/12-27;
D3/297, 273, 276, 283; D6/432, 510, 474,
D6/449, 396, 399, 626, 629, 349; 190/100,
190/115; 280/79.11, 32.6, 639, 652, 654,
280/47.24, 47.11, 47.34; 108/55.3

See application file for complete search history.

(56) **References Cited**

U.S. PATENT DOCUMENTS

132,165	A	*	10/1872	Maples	312/246
D30,552	S	*	4/1899	Gimbel et al.	D6/330
D46,436	S	*	9/1914	Karpeles	D6/436
1,171,450	A	*	2/1916	McIntyre	280/32.5
1,416,429	A	*	5/1922	Williams	280/32.5
1,457,567	A	*	6/1923	Benjamin et al.	280/32.5
2,448,427	A	*	8/1948	Gordon	280/32.5
D214,491	S	*	6/1969	Maris	D34/18
D223,064	S	*	3/1972	Peterson	D6/449
4,203,609	A	*	5/1980	Mitchell et al.	280/47.11
D259,597	S	*	6/1981	Marks	D6/349
D269,960	S	*	8/1983	Cosper	D12/85
314,653	A		2/1991	Jackson		
353,702	A		12/1994	Martinez et al.		
5,380,021	A		1/1995	Doherty		
D364,290	S	*	11/1995	Watts	D6/474
D370,366	S	*	6/1996	Watts	D6/449
5,577,744	A	*	11/1996	Parks	280/32.6

381,170	A		7/1997	Dawkins		
D399,626	S	*	10/1998	Taylor	D34/23
D402,815	S	*	12/1998	Silva	D6/349
5,967,544	A	*	10/1999	Kanta	280/652
D439,743	S	*	4/2001	DeVance	D3/297
D466,668	S		12/2002	Peschmann		
D469,592	S		1/2003	Brimhall et al.		
D472,028	S		3/2003	Stahl		
D472,358	S		3/2003	Beese, Jr.		
D474,340	S	*	5/2003	Vasudeva	D3/282
D499,883	S	*	12/2004	Perella et al.	D3/276
D501,591	S	*	2/2005	Lucht	D34/12

* cited by examiner

Primary Examiner—Freda Nunn

Assistant Examiner—Kevin K. Rudzinski

(74) *Attorney, Agent, or Firm*—Emch, Schaffer, Schaub & Porcello Co., L.P.A.

(57) **CLAIM**

The ornamental design for the knee cart, as shown and described.

DESCRIPTION

FIG. 1 is a top plan view of the knee cart according to the present design;

FIG. 2 is a left side elevational view thereof;

FIG. 3 is a bottom plan view of FIG. 1;

FIG. 4 is a right side elevational view of FIG. 1;

FIG. 5 is a backside elevational view of FIG. 1;

FIG. 6 is a front side elevational view of FIG. 1; and,

FIG. 7 is a front and top perspective view of the knee cart according to the present design showing the utility work station extended therefrom.

The broken line showing of wheels is for illustrative purposes only and form no part of the claimed design.

1 Claim, 4 Drawing Sheets

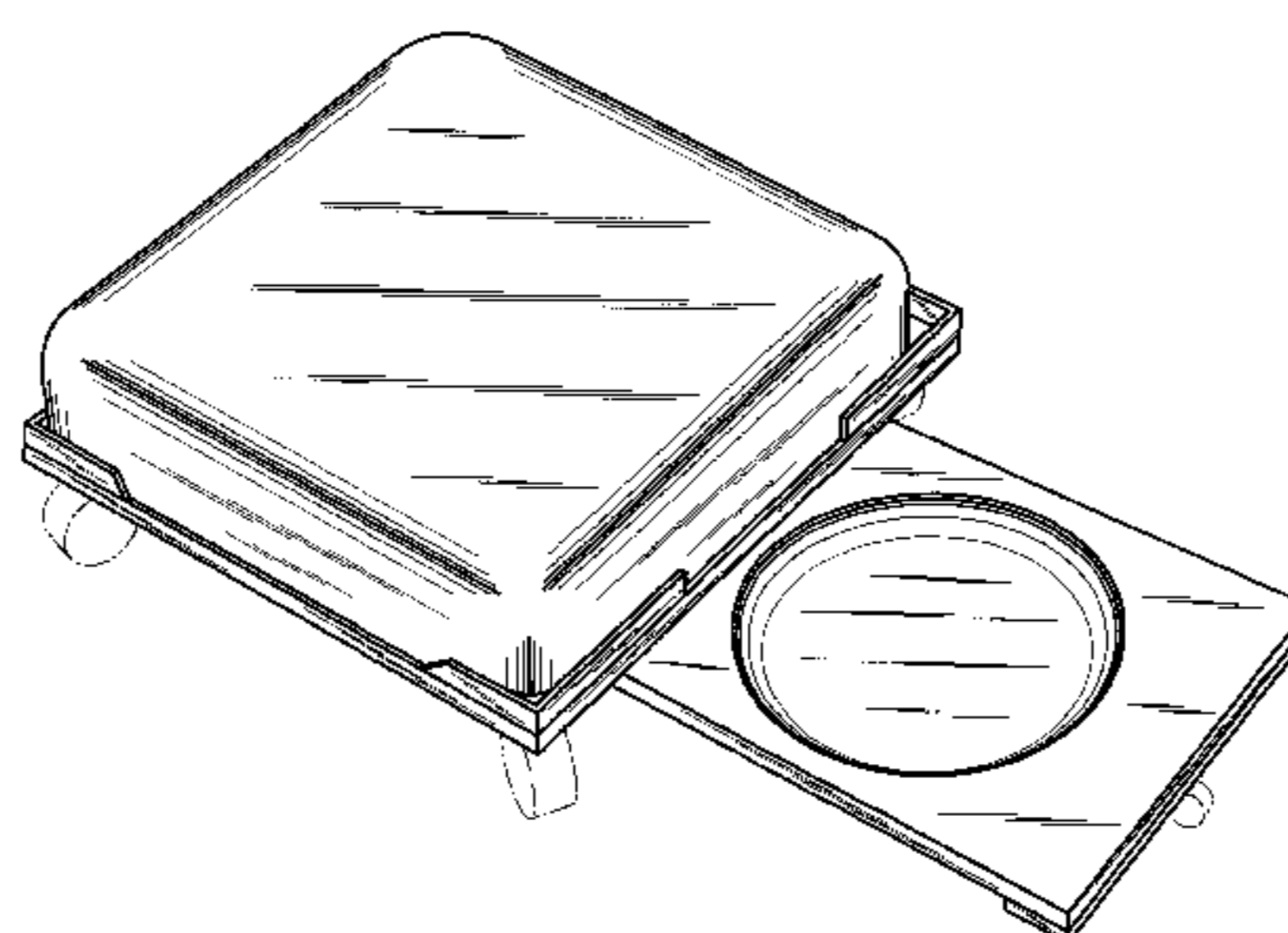
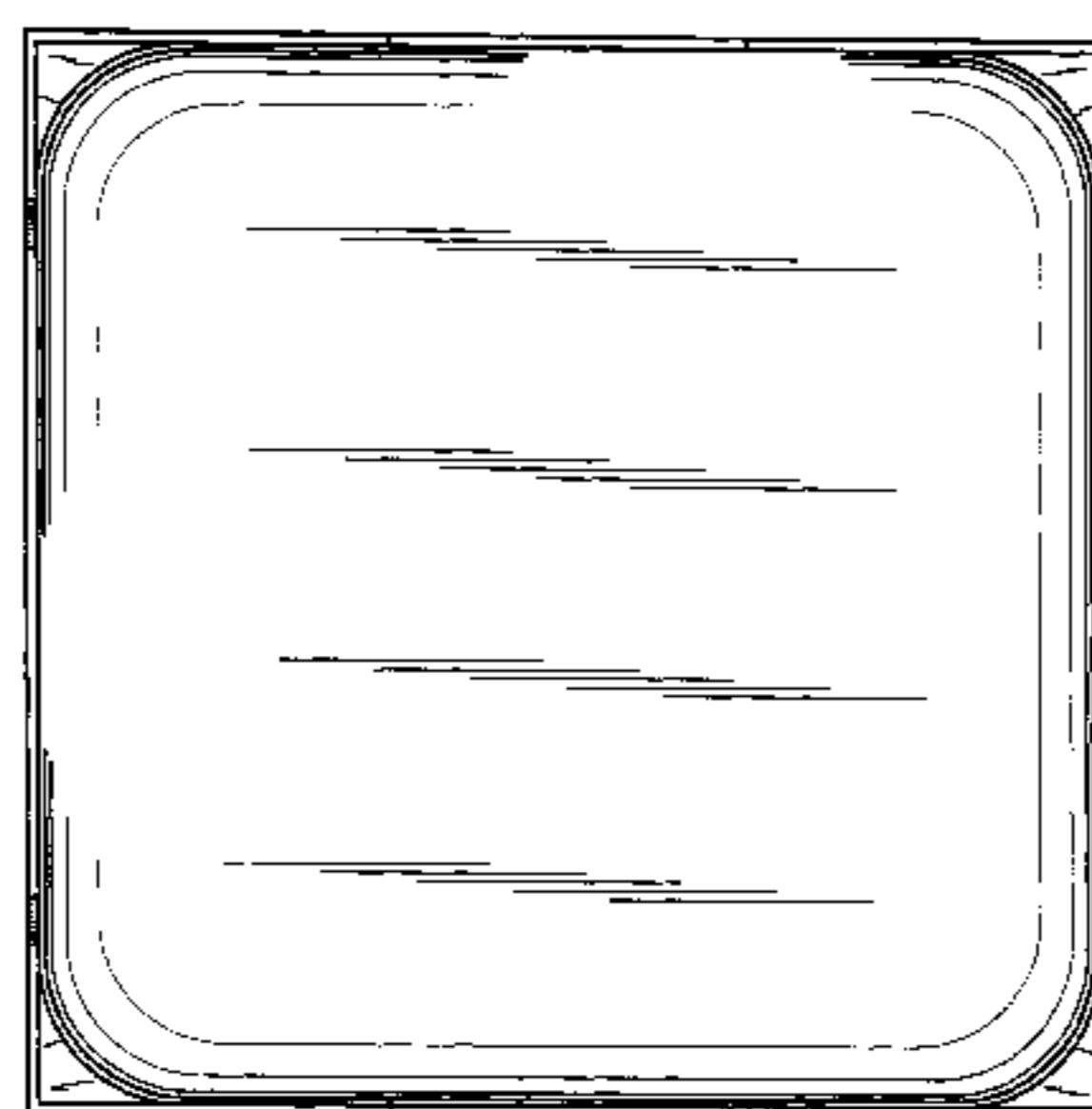

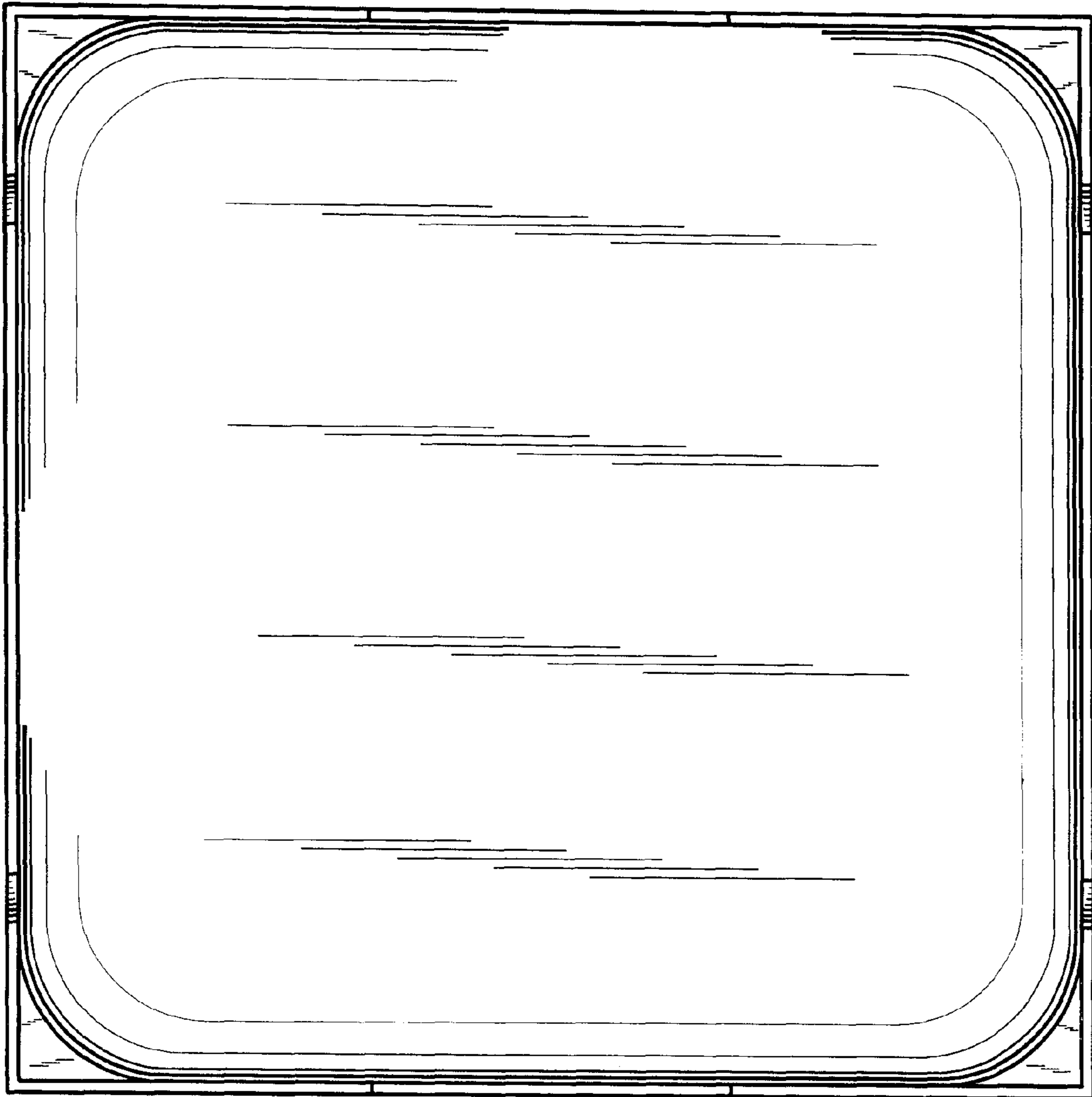

FIG. 1

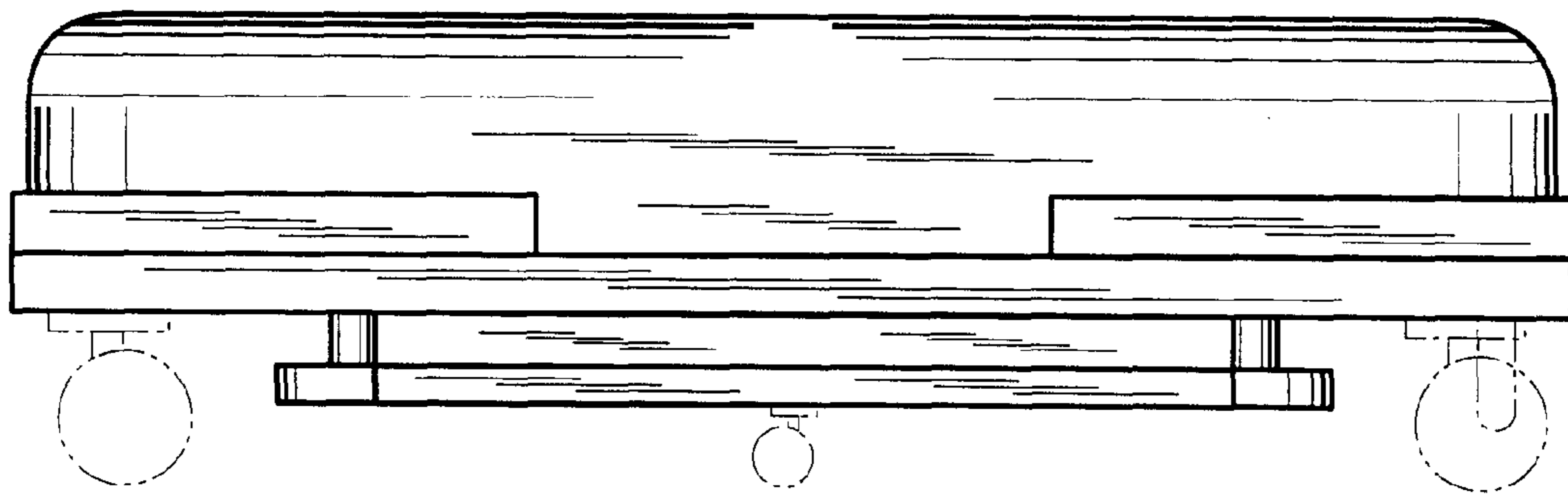
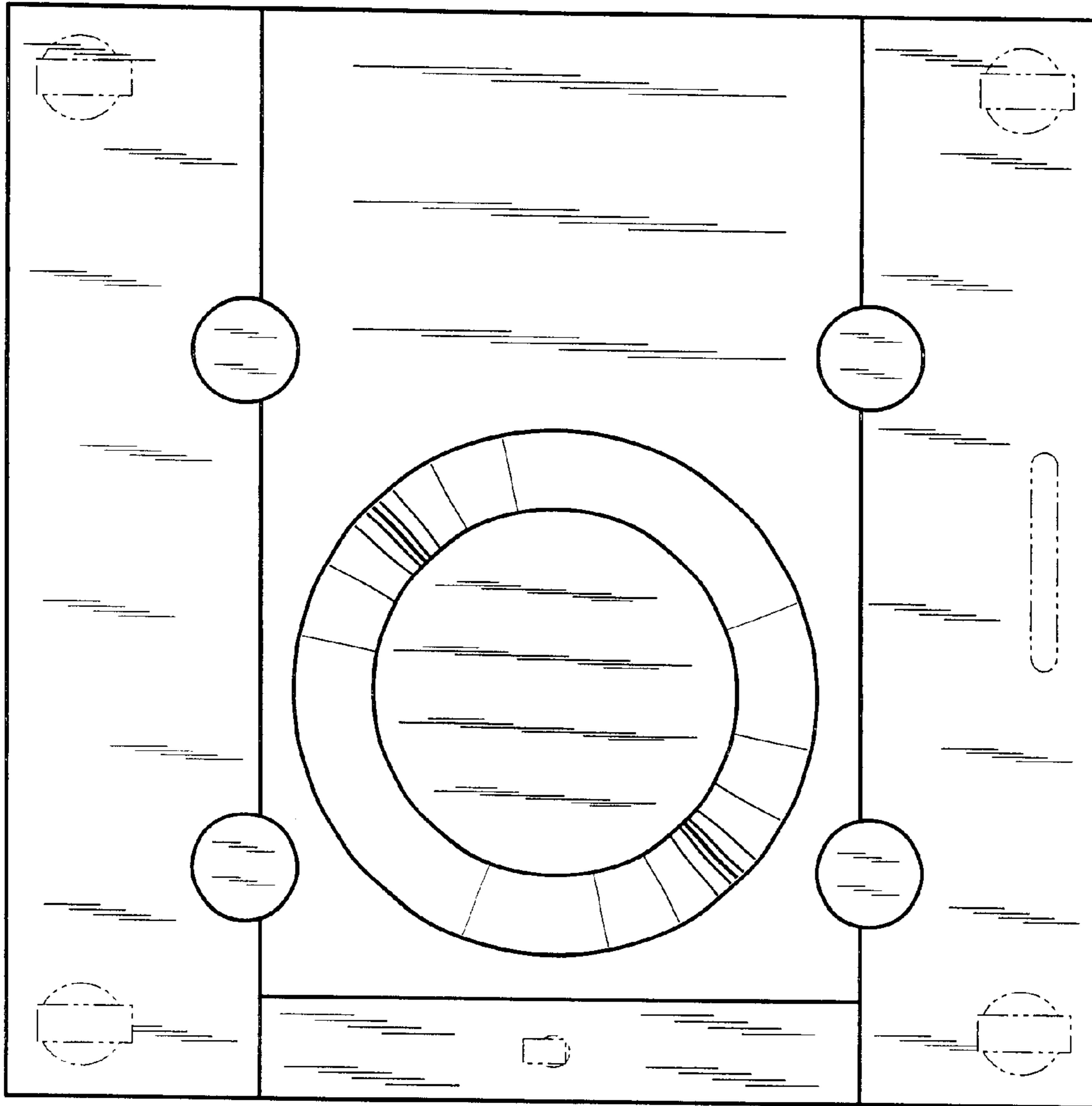
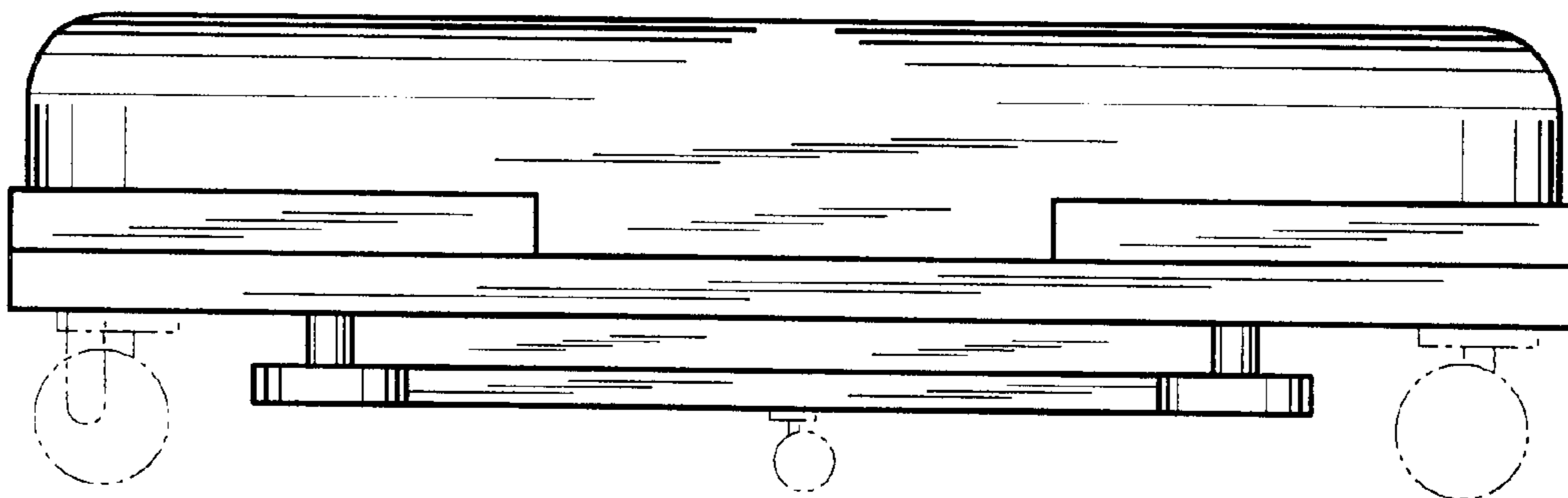

FIG. 2



—FIG. 3



—FIG. 4

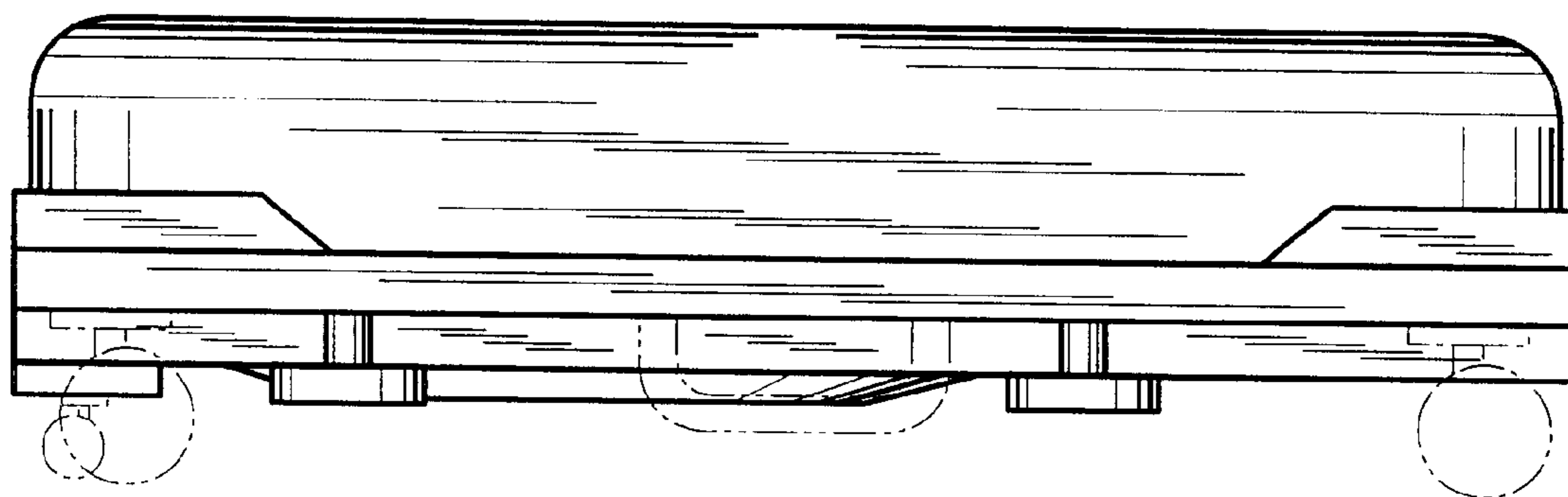

—FIG. 5

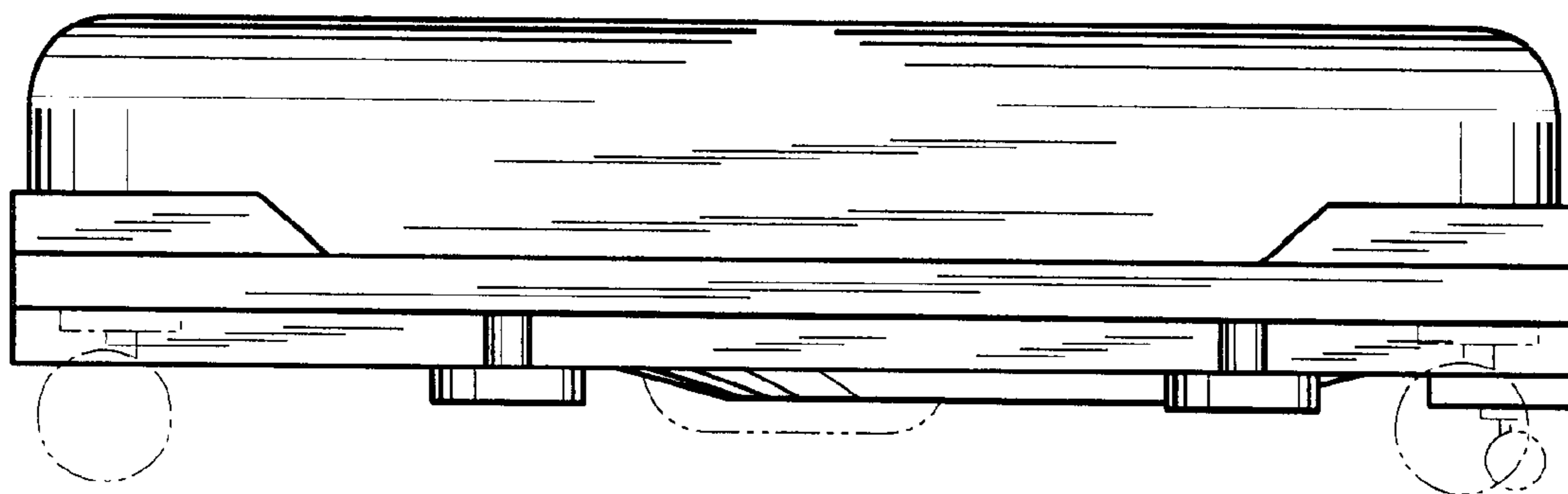

—FIG. 6

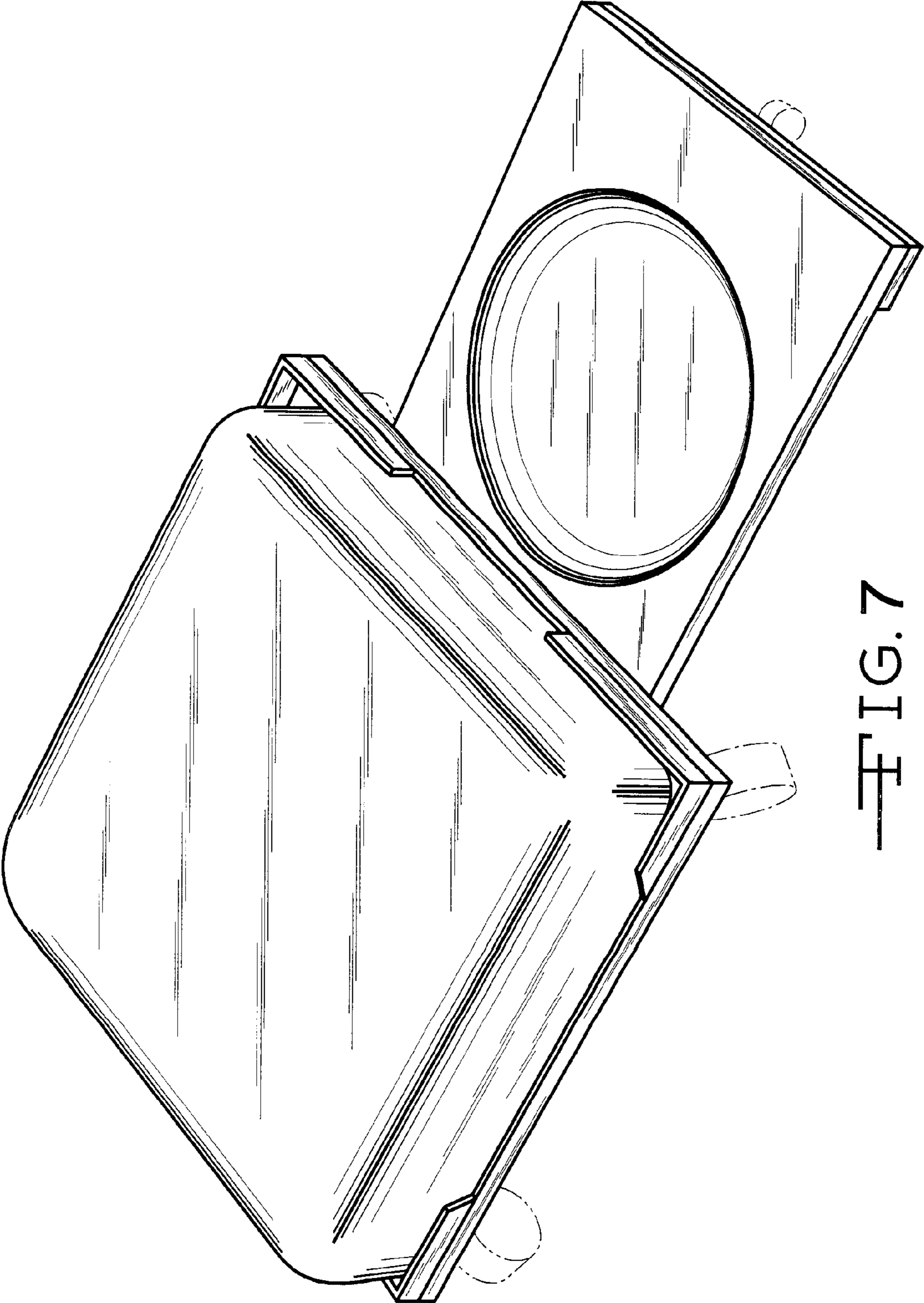

FIG. 7