



US00D523905S

(12) **United States Design Patent**  
**Netzel et al.**

(10) **Patent No.:** **US D523,905 S**  
(45) **Date of Patent:** **\*\* Jun. 27, 2006**

(54) **DRIVE-UP, CAR WINDOW-ACCESSIBLE VENDING MACHINE**

(76) Inventors: **Sally J. Netzel**, N. 10147 County S, Marion, WI (US) 54950; **Sarah J. Netzel**, 97 McKinley Ave., Clintonville, WI (US) 54929

(\*\*) **Term:** **14 Years**

(21) **Appl. No.:** **29/238,592**

(22) **Filed:** **Sep. 19, 2005**

(51) **LOC (8) Cl.** ..... **20-01**

(52) **U.S. Cl.** ..... **D20/4**

(58) **Field of Classification Search** ..... D20/1, D20/2, 3, 4, 5, 6, 7, 8, 9, 99; D7/301, 304, D7/305, 307, 308, 312, 313, 398; D23/284; 194/239, 320, 342, 350, 351, 352, 906; 221/92, 221/96, 104, 151, 155, 191, 194; 239/28, 239/29; 700/232

See application file for complete search history.

(56) **References Cited**

**U.S. PATENT DOCUMENTS**

- 1,932,014 A \* 10/1933 Frankford ..... 194/219
- D97,505 S \* 11/1935 Rowe ..... D20/4
- 2,205,875 A 6/1940 Coffey et al.
- D150,154 S \* 7/1948 Meagher ..... D20/3
- D151,953 S \* 12/1948 Babcock ..... D20/4
- D156,155 S \* 11/1949 Otto ..... D20/4
- 2,989,165 A \* 6/1961 Cozart ..... 194/246

- D228,522 S 10/1973 Smith
- D266,773 S 11/1982 Poirier
- D268,840 S \* 5/1983 Reed ..... D7/300
- D292,719 S \* 11/1987 Maass ..... D20/1
- D294,271 S 2/1988 Glaser
- D305,981 S 2/1990 Levee
- D332,469 S \* 1/1993 Bowman ..... D20/4
- D334,029 S \* 3/1993 Reising ..... D20/1
- 5,785,204 A 7/1998 Thompson et al.
- D415,383 S 10/1999 Le
- 6,253,956 B1 \* 7/2001 Khan et al. .... 221/211
- 6,726,101 B1 \* 4/2004 McIntyre et al. .... 235/382

\* cited by examiner

*Primary Examiner*—Robert M. Spear

(74) *Attorney, Agent, or Firm*—Donald R. Schoonover

(57) **CLAIM**

We claim the ornamental design for a drive-up, car window-accessible vending machine, as shown and described.

**DESCRIPTION**

FIG. 1 is a perspective view of a drive-up, car window-accessible vending machine showing our new design; FIG. 2 is a front elevational view thereof; FIG. 3 is a rear elevational view thereof; FIG. 4 is a right side elevational view thereof, the left side elevational view being a mirror image thereof; FIG. 5 is a top plan view thereof; and, FIG. 6 is a bottom plan view thereof.

**1 Claim, 3 Drawing Sheets**

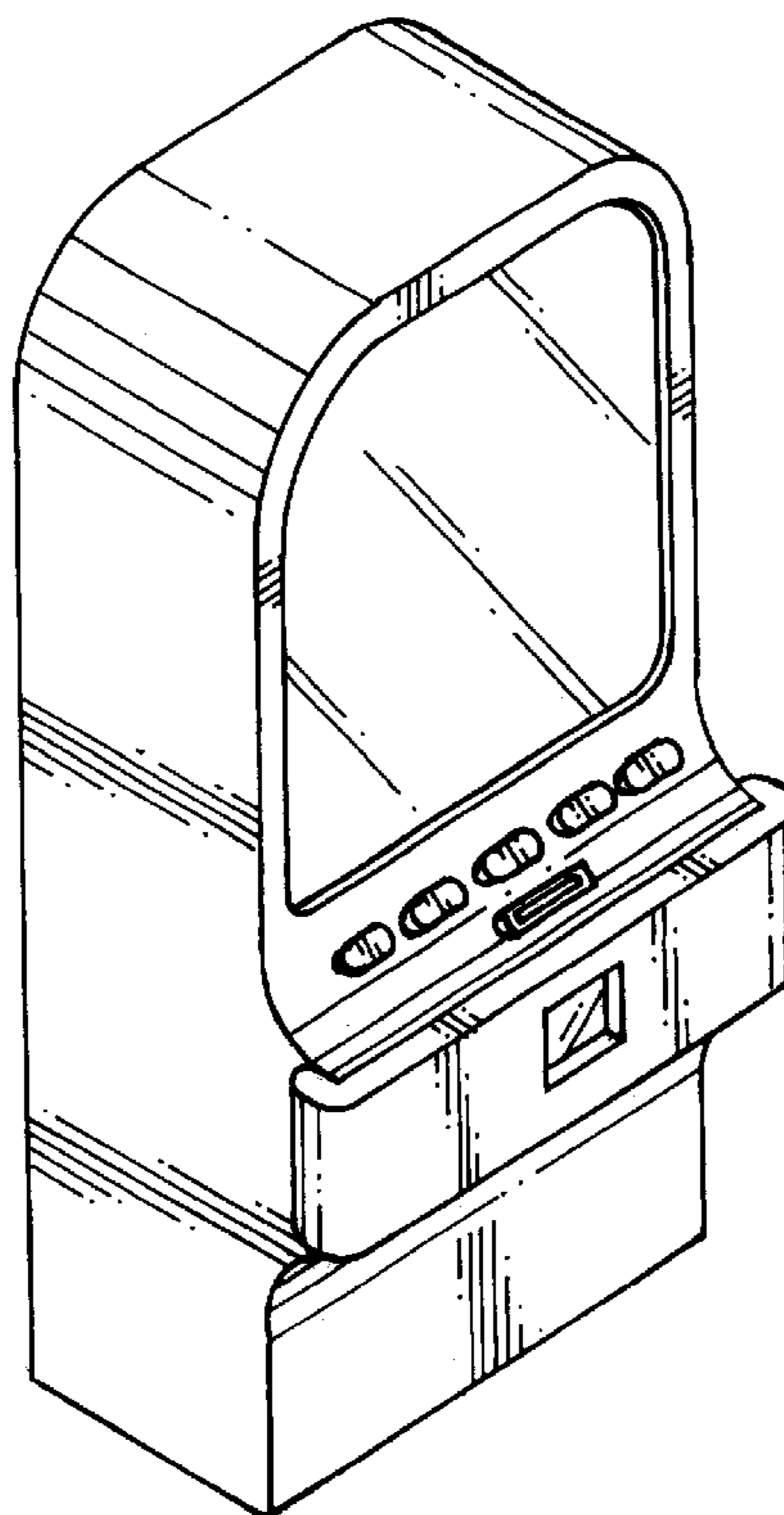

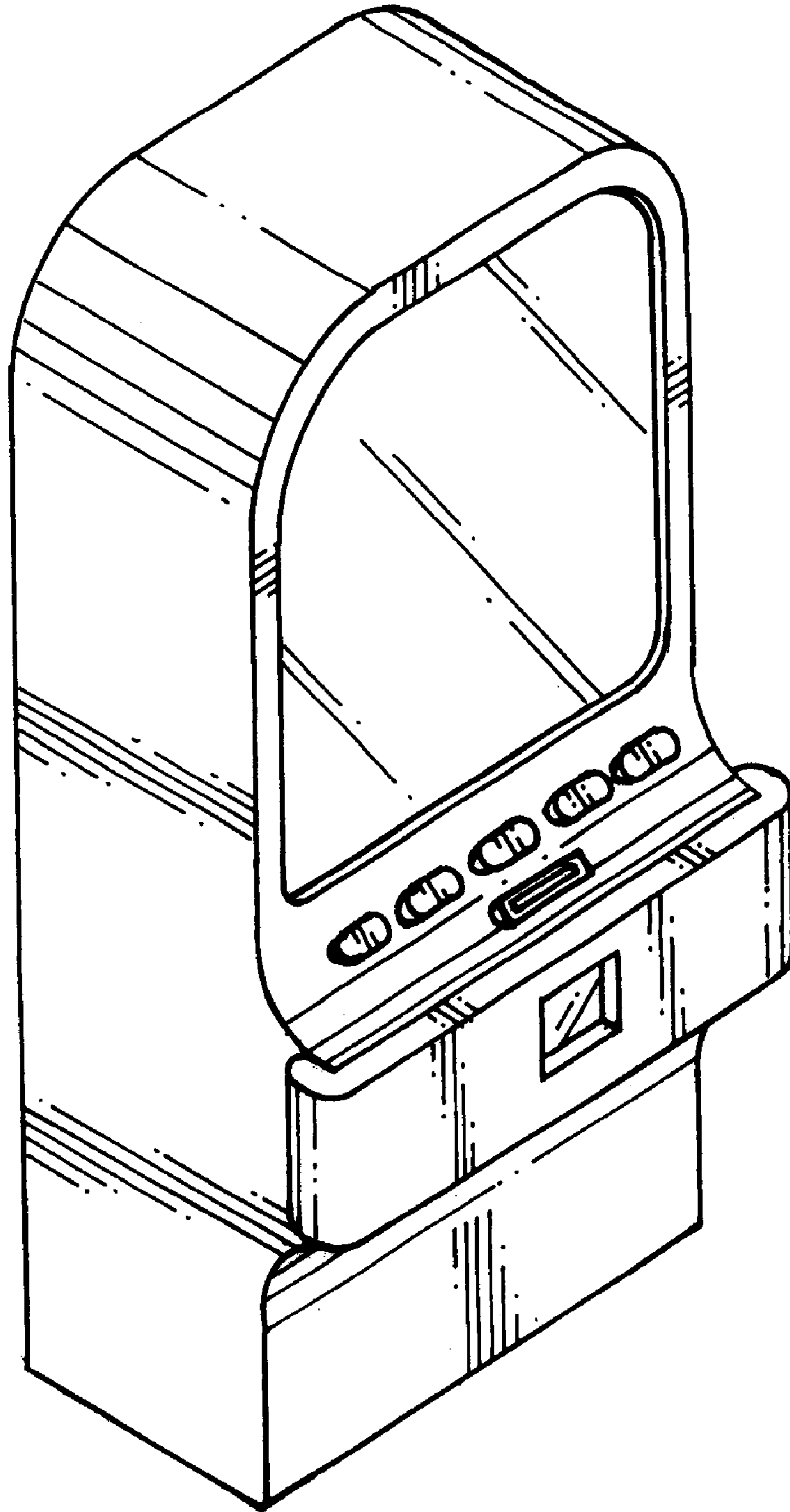

FIG. 1.

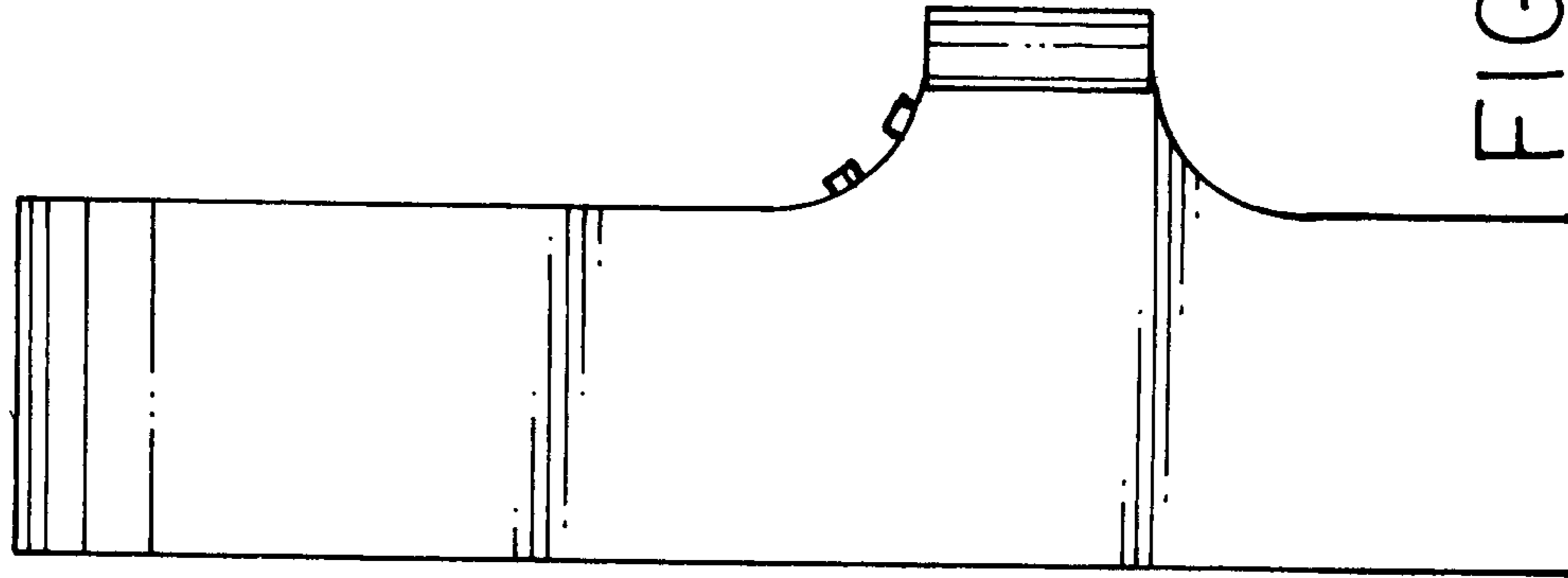

FIG. 4.

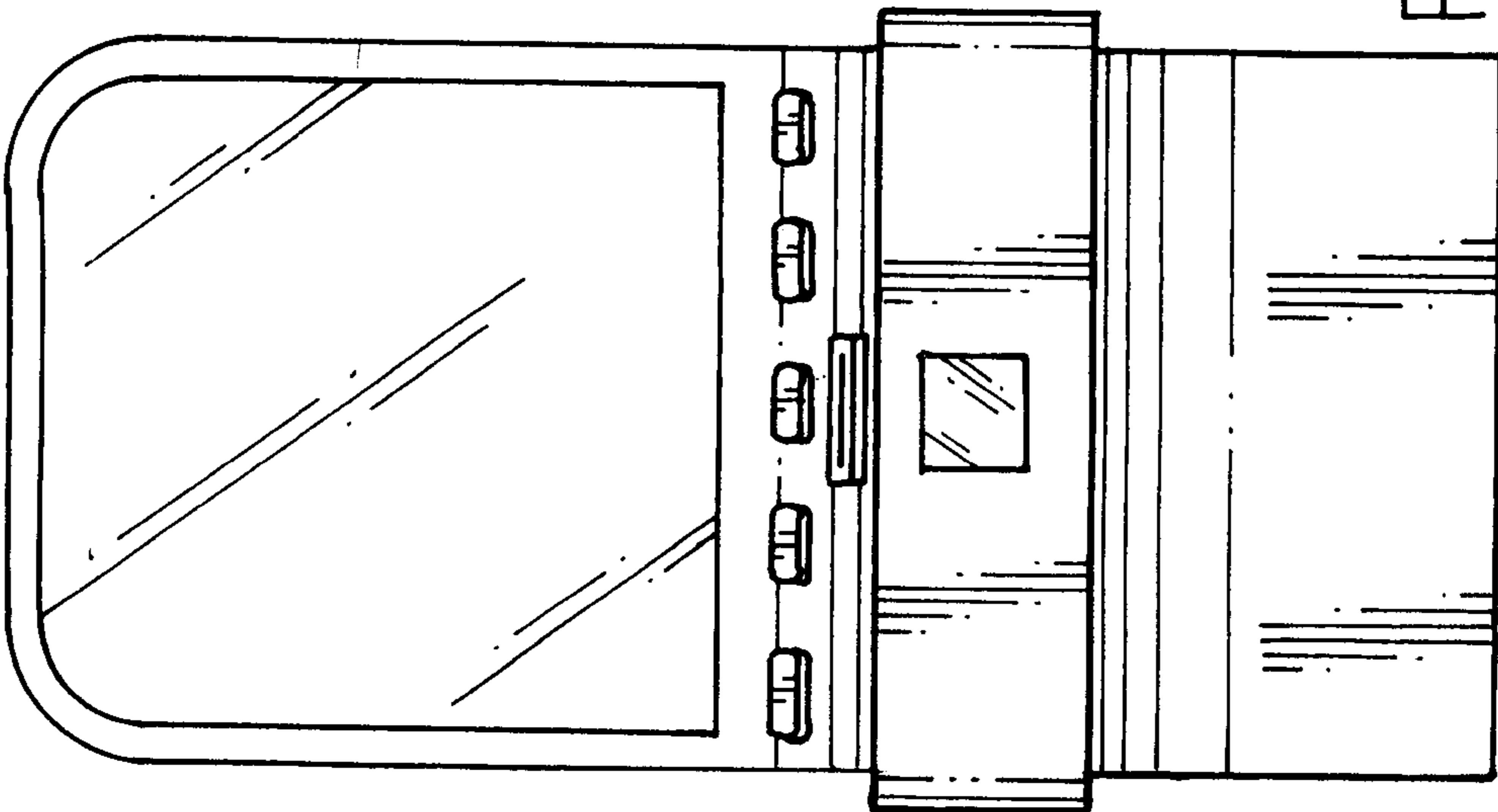

FIG. 2.

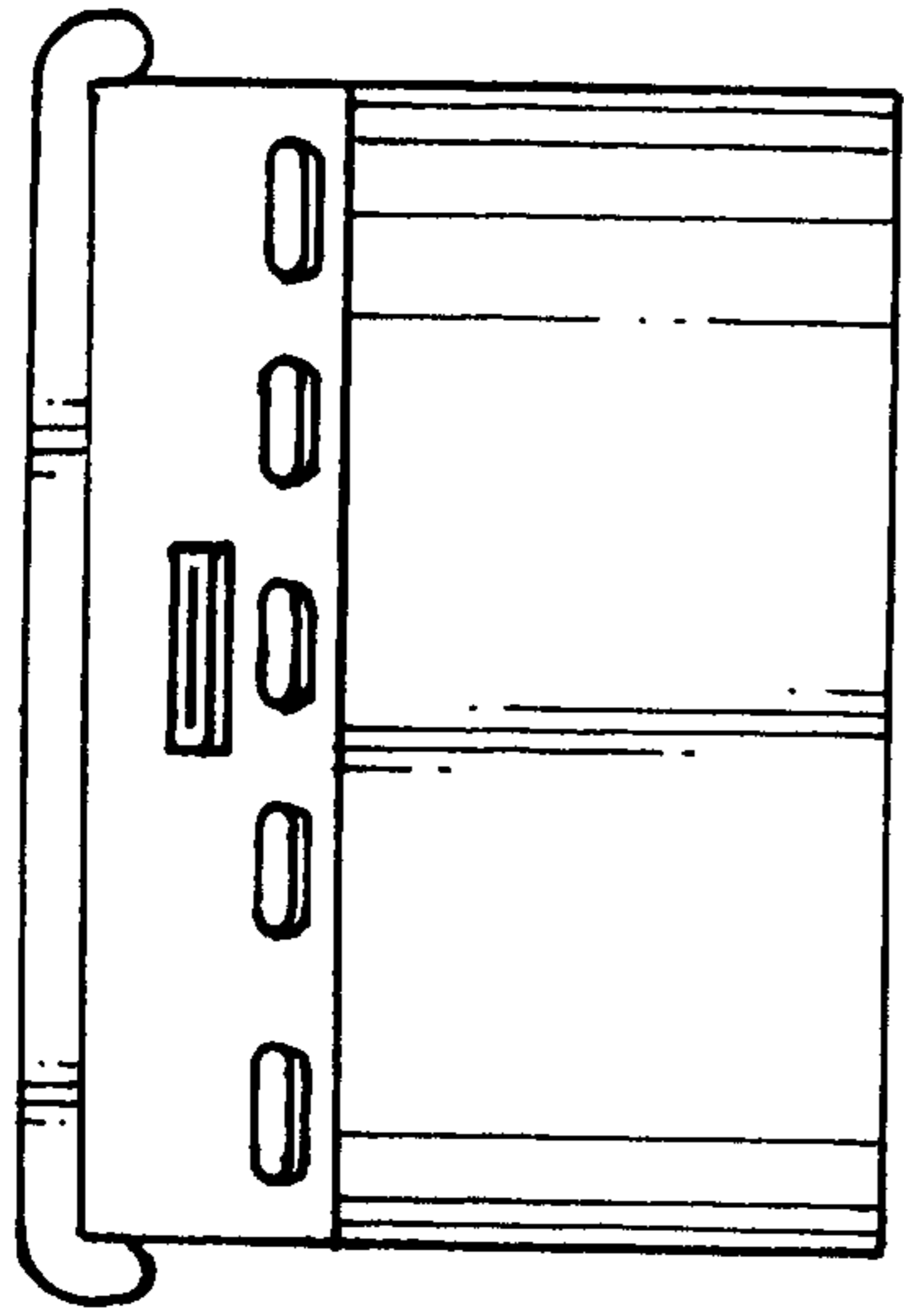

FIG. 5.

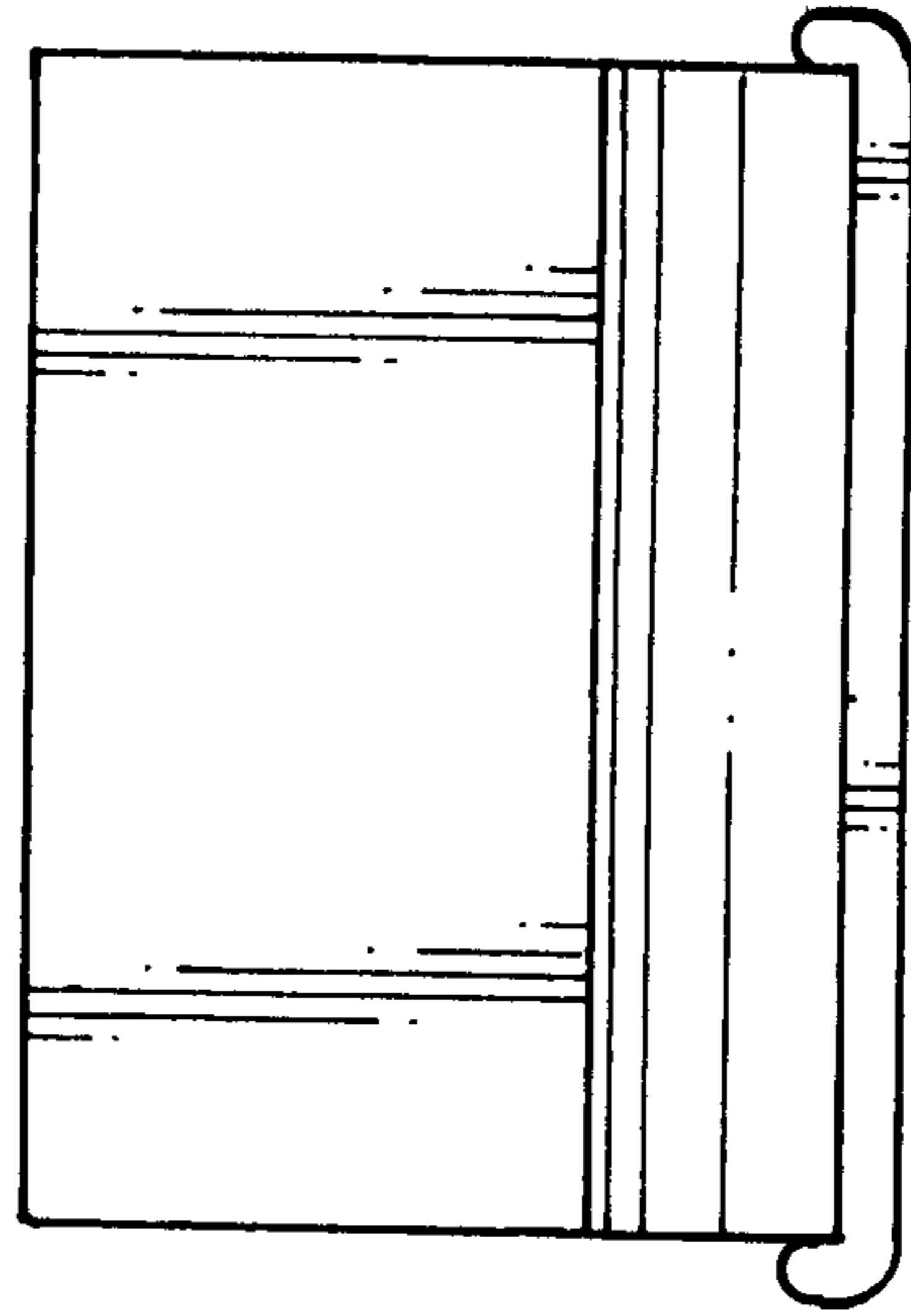

FIG. 6.

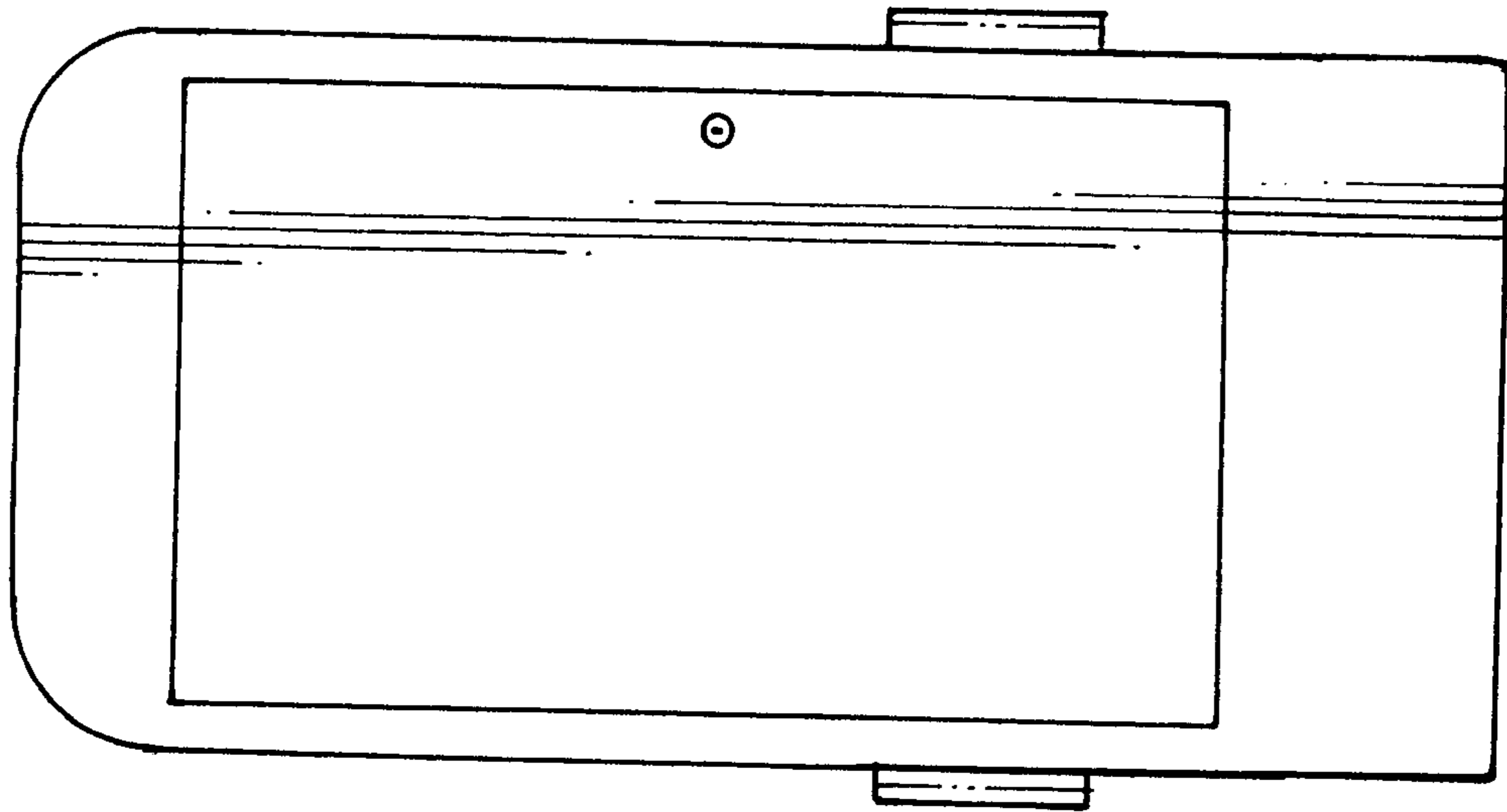

FIG. 3.